

**SUZUKI**

**GSXR 1100**

**SERVICE MANUAL**

99500-39092-03E  
(英)

## FOREWORD

The SUZUKI GSX-R1100 has been developed as a new generation motorcycle to the GS-models. It is packed with highly advanced design concepts including a Suzuki Advanced Cooling System, a new highly efficient combustion system (TSCC), a fully transistorized ignition system and a improved full-floater rear suspension. Combined with precise control and easy handling the GSX-R1100 provides excellent performance and outstanding riding comfort.

This service manual has been produced primarily for experienced mechanics whose job is to inspect, adjust, repair and service SUZUKI motorcycles. Apprentice mechanics and do-it-yourself mechanics, will also find this manual an extremely useful repair guide. This manual contains the most up-to-date information at the time of publication. The rights are reserved to update or make corrections to this manual at any time.

## IMPORTANT

All street-legal Suzuki motorcycles with engine displacement of 50cc or greater are subject to Environmental Protection agency emission regulations. These regulations set specific standards for exhaust emission output levels as well as particular servicing requirements. This manual includes specific information required to properly inspect and service GSX-R1100 in accordance with all EPA regulations. It is strongly recommended that the chapter on Emission Control, Periodic Servicing and Carburetion be thoroughly reviewed before any type of service work is performed.

Further information concerning the EPA emission regulations and U.S. Suzuki's emission control program can be found in the U.S. SUZUKI EMISSION CONTROL PROGRAM MANUAL/SERVICE BULLETIN.

## SUZUKI MOTOR CORPORATION

Motorcycle Technical  
Service Department

## GROUP INDEX

GENERAL INFORMATION

1

PERIODIC MAINTENANCE AND  
TUNE-UP PROCEDURES

2

ENGINE

3

FUEL AND LUBRICATION  
SYSTEM

4

ELECTRICAL SYSTEM

5

CHASSIS

6

SERVICING INFORMATION

7

EMISSION CONTROL  
INFORMATION

8

GSX-R1100L ('90-MODEL)

9

GSX-R1100M ('91-MODEL)

10

GSX-R1100N ('92-MODEL)

11

# VIEW OF GSX-R1100K



RIGHT SIDE



LEFT SIDE



## SERIAL NUMBER LOCATION

The frame serial number or V.I.N. (Vehicle Identification Number) ① is stamped on the steering head pipe. The engine serial number ② is located on the right side of the crankcase. These numbers are required especially for registering the machine and ordering spare parts.

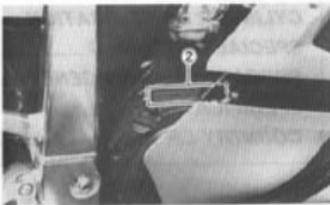

## FUEL AND OIL RECOMMENDATION

### FUEL (For U.S.A. model)

1. Use only unleaded gasoline of at least 87 pump octane ( $\frac{R+M}{2}$ ) method or 91 octane or higher rated by the research method.
2. Suzuki recommends that customers use alcohol free, unleaded gasoline whenever possible.
3. Use of blended gasoline containing MTBE (Methyl Tertiary Butyl Ether) is permitted.
4. Use of blended gasoline/alcohol fuel is permitted provided that it contains not more than 10% ethanol. Gasoline/alcohol fuel may contain up to 5% methanol if appropriate cosolvents and corrosion inhibitors are present.
5. If the performance of the vehicle is unsatisfactory while using blended gasoline/alcohol fuel, you should switch to alcohol free unleaded gasoline.
6. Failure to follow these guideline could possibly void applicable warranty coverage. Check with your fuel supplier to be sure that the fuel you intend to use meets the requirements listed above.

### FUEL (For Canadian model)

Use only unleaded gasoline of at least 87 pump octane ( $\frac{R+M}{2}$ ) method or 91 octane or higher rated by the research method.

### FUEL (For the other models)

Gasoline used should be graded 85-95 octane (Research Method) or higher. An unleaded gasoline type is recommended.



## SPECIAL MATERIALS

The materials listed below are needed for maintenance work on the GSX-R1100, and should be kept on hand for ready use. They supplement such standard materials as cleaning fluids, lubricants, emery cloth and the like. How to use them and where to use them are described in the text of this manual.

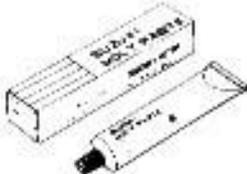
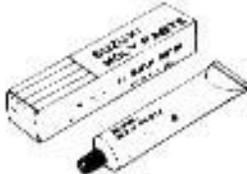
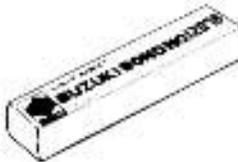
MATERIAL		PART	PAGE
For U.S.A model	For other models		
 <p>SUZUKI SUPER GREASE "A" 99000-25030</p>	 <p>SUZUKI SUPER GREASE "A" 99000-25010</p>	<ul style="list-style-type: none"> <li>• Driveshaft oil seal</li> <li>• Engine oil pipe O-ring</li> <li>• Oil filter</li> <li>• Generator oil seal</li> <li>• Starter motor oil seal</li> <li>• Wheel bearing</li> <li>• Steering stem bearing</li> <li>• Sprocket mounting drum bearing</li> <li>• Swingarm spacer and dust seal cover</li> <li>• Cushion lever bearing and dust seal</li> </ul>	<p>3-49</p> <p>3-63</p> <p>4-18</p> <p>5-7</p> <p>5-17</p> <p>6-4</p> <p>6-32</p> <p>6-20</p> <p>6-33</p> <p>6-46</p> <p>6-46</p>
 <p>SUZUKI MOLY PASTE 99000-25140</p>	 <p>SUZUKI MOLY PASTE 99000-25140</p>	<ul style="list-style-type: none"> <li>• Valve stem</li> <li>• Conrod big end bearing</li> <li>• Countershaft and driveshaft</li> <li>• Crankshaft journal bearing</li> <li>• Camshaft journal</li> <li>• Starter motor armature end damper</li> <li>• Clutch lever push rod</li> </ul>	<p>3-30</p> <p>3-39</p> <p>3-48</p> <p>3-54</p> <p>3-64</p> <p>5-17</p> <p>5-6</p> <p>6-48</p>
 <p>SUZUKI BOND NO. 1207B 99104-31140</p>	 <p>SUZUKI BOND NO. 1207B 99000-31140</p>	<ul style="list-style-type: none"> <li>• Crankcase mating surface</li> <li>• Clutch cover mating surface</li> <li>• Starter clutch cover mating surface</li> <li>• Oil pressure switch</li> <li>• Signal generator lead wire grommet</li> <li>• Cylinder head cover</li> <li>• Cam end cap</li> <li>• Cylinder stud bolt</li> </ul>	<p>3-54</p> <p>3-58</p> <p>3-60</p> <p>3-58</p> <p>3-58</p> <p>3-68</p> <p>3-68</p> <p>3-61</p>
 <p>THREAD LOCK SUPER "1303" 99000-32030</p>	 <p>THREAD LOCK SUPER "1303" 99000-32030</p>	<ul style="list-style-type: none"> <li>• Cam sprocket bolt</li> <li>• Cam chain guide bolt</li> </ul>	<p>3-33</p> <p>3-34</p>
 <p>THREAD LOCK SUPER "1360" 99000-32130</p>	 <p>THREAD LOCK SUPER "1360" 99000-32130</p>	<ul style="list-style-type: none"> <li>• Disc plate mounting bolt</li> </ul>	<p>6-5</p> <p>6-34</p>

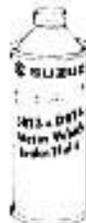
MATERIAL		PART	PAGE
For U.S.A model	For other models		
 <p>THREAD LOCK "1342" 99000-32050</p>	 <p>THREAD LOCK "1342" 99000-32050</p>	<ul style="list-style-type: none"> <li>• Gearshift cam stopper bolt</li> <li>• Oil pump mounting bolt</li> <li>• Countershaft bearing retainer screw</li> <li>• Gearshift cam guide/pawl lifter screw</li> <li>• Starter motor mounting bolt</li> <li>• Generator bearing retainer screw</li> <li>• Starter motor housing screw</li> <li>• Front fork damper rod bolt</li> <li>• Steering damper bolt</li> </ul>	<p>3-23</p> <p>3-52</p> <p>3-55</p> <p>3-55</p> <p>3-60</p> <p>5-8</p> <p>5-17</p> <p>6-14</p> <p>6-20</p>
 <p>THREAD LOCK SUPER "1303" 99000-32030</p>	 <p>THREAD LOCK SUPER "1305" 99000-32100</p>	<ul style="list-style-type: none"> <li>• Starter clutch mounting bolt</li> </ul>	<p>3-59</p>
 <p>SUZUKI BRAKE FLUID DOT3 &amp; DOT4 99000-23110</p>	 <p>SUZUKI BRAKE FLUID DOT3 &amp; DOT4 99000-23110</p>	<ul style="list-style-type: none"> <li>• Clutch</li> <li>• Brakes</li> </ul>	<p>2-9</p> <p>2-12</p>
 <p>SUZUKI FORK OIL #5 99000-99044.05G</p>	 <p>SUZUKI FORK OIL #5 99000-99044.05G</p>		<p>6-16</p>
 <p>THREAD LOCK CEMENT 99000-32040</p>	 <p>THREAD LOCK CEMENT 99000-32040</p>	<ul style="list-style-type: none"> <li>• Carburetor set plate screw</li> </ul>	<p>4-12</p>



## PRECAUTIONS AND GENERAL INSTRUCTIONS

Observe the following items without fail when servicing, disassembling and reassembling motorcycles.

- Do not run engine indoors with little or no ventilation.
- Be sure to replace packings, gaskets, circlips, O-rings and cotter pins with new ones.

### CAUTION:

**Never reuse a circlip. After a circlip has been removed from a shaft, it should be discarded and a new circlip must be installed.**

**When installing a new circlip, care must be taken not to expand the end gap larger than required to slip the circlip over the shaft.**

**After installing a circlip, always insure that it is completely seated in its groove and securely fitted.**

- Tighten cylinder head and case bolts and nuts, beginning with larger diameter and ending with smaller diameter, from inside to out-side diagonally, to the specified tightening torque.
- Use special tools where specified.
- Use genuine parts and recommended oils.
- When 2 or more persons work together, pay attention to the safety of each other.
- After the reassembly, check parts for tightness and operation.
- Treat gasoline, which is extremely flammable and highly explosive, with greatest care. Never use gasoline as cleaning solvent.

Warning, Caution and Note are included in this manual occasionally, describing the following contents.

**WARNING**..... The personal safety of the rider or bystanders may be involved. Disregarding this information could result in personal injury.

**CAUTION**..... These instructions point out special service procedures or precautions that must be followed to avoid damaging the machine.

**NOTE**..... This provides special information to make maintenance easier or important instructions clearer.

## REPLACEMENT PARTS

When you replace any parts, use only genuine SUZUKI replacement parts, or their equivalent. Genuine SUZUKI parts are high quality parts which are designed and built specifically for SUZUKI vehicles.

### CAUTION:

**Use of replacement parts which are not equivalent in quality to genuine SUZUKI parts can lead to performance problems and damage.**

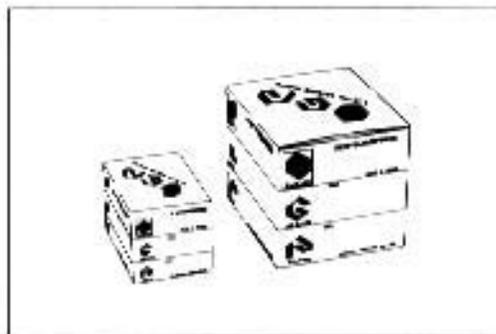

## ASBESTOS INFORMATION

Note the following when handling a supply part with this WARNING LABEL, or any part in the parts list which contains asbestos.

- Operate if possible out of doors in a well ventilated place.
- Preferably use hand tools or low speed tools equipped, if necessary, with an appropriate dust extractor facility. If high speed tools are used, they should always be so equipped.
- If possible, dampen before cutting or drilling.
- Dampen dust and place it in a properly closed receptacle and dispose of it safely.

Any domestic asbestos product to which the above does not apply, but which is likely to release fibres during use should be replaced by new one when worn.

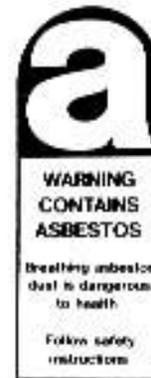

1.	Breather cover gasket
2.	Clutch cover gasket
3.	Signal generator cover gasket
4.	Starter gear cover gasket
5.	Oil pan gasket
6.	Cam chain tension adjuster gasket
7.	Exhaust pipe gasket
8.	Oil strainer protector gasket
9.	Starter motor
10.	Fuel cock gasket
11.	Fuel tank heat shield

## SPECIFICATIONS

### DIMENSIONS AND DRY MASS

Overall length.....	2050 mm (80.7 in)
Overall width.....	755 mm (29.7 in)
Overall height.....	1150 mm (45.3 in)
Wheelbase.....	1440 mm (56.7 in)
Ground clearance.....	110 mm (4.3 in)
Dry mass.....	211 kg (465 lbs)..... For Switzerland model
	212 kg (467 lbs)..... For California model
	210 kg (463 lbs)..... For the other models

### ENGINE

Type.....	Four-stroke, Air-cooled with SACS, DOHC, TSCC
Number of cylinders.....	4
Bore.....	78.0 mm (3.07 in)
Stroke.....	59.0 mm (2.32 in)
Piston displacement.....	1127cm <sup>3</sup> (68.8 cu.in)
Carburetor.....	MIKUNI BST36SS, four
Air cleaner.....	Polyester fiber element
Starter system.....	Electric starter
Lubrication system.....	Wet sump

### TRANSMISSION

Clutch.....	Wet multi-plate type, hydraulically operated
Transmission.....	5-speed constant mesh
Gearshift pattern.....	1-down, 4-up
Primary reduction.....	1.565 (72/46)
Final reduction.....	3.200 (48/15)
Gear ratios, Low.....	2.384 (31/13)
2nd.....	1.631 (31/19)
3rd.....	1.250 (25/20)
4th.....	1.045 (23/22)
Top.....	0.913 (21/23)
Drive chain.....	TAKASAGO RK532GSV, 114 links

## CHASSIS

Front suspension.....	Telescopic, coil spring, oil damped, inner rod type, spring pre-load fully adjustable, damping force compression 10-way and rebound 8-way adjustable.
Rear suspension.....	Full-floating suspension system, gas/oil damped, coil spring, spring pre-load fully adjustable, damping force 4-way adjustable
Steering angle.....	30° (right & left)
Caster.....	65° 10'
Trail.....	99 mm (3.9in)
Turning radius.....	3.2 m (10.5ft)
Front brake.....	Disc brake, twin
Rear brake.....	Disc brake
Front tire size.....	120/70ZR17
Rear tire size.....	160/60ZR17
Front fork stroke.....	120mm (4.7in)
Rear wheel travel.....	140mm (5.5in)

## ELECTRICAL

Ignition type.....	Fully Transistorized
Ignition timing.....	7° B.T.D.C. at 1500 r/min---- For California model 13° B.T.D.C. at 1500 r/min---- For the other models
Spark plug.....	N.G.K.: J99B
Battery.....	12V 50.4 kC (14Ah)/10HR
Generator.....	Three-phase A.C. Generator
Fuse.....	10/10/10/10/10A
Circuit breaker.....	30A

## CAPACITIES

Fuel tank, including reserve.....	18.5 L (4.8/4.1 US/Imp gal)---- For California model 20.5 L (5.4/4.5 US/Imp gal)---- For Switzerland model 21.0 L (5.5/4.6 US/Imp gal)---- For the other models
Engine oil, Oil change with oil filter change.....	4.2 L (4.4/3.7 US/Imp qt)
Front fork oil.....	453 ml (15.3/16.0 US/Imp oz)---- For U.S.A. model 418 ml (14.1/14.7 US/Imp oz)---- For the other models

These specifications are subject to change without notice.

**COUNTRY OR AREA**

The series of symbols on the left stand for the countries and areas on the right.

SYMBOL	COUNTRY or AREA
E-01	General
E-02	England
E-03	U.S.A.
E-04	France
E-15	Finland
E-16	Norway
E-17	Sweden
E-18	Switzerland
E-21	Belgium
E-22	W Germany
E-24	Australia
E-25	Netherlands
E-28	Canada
E-33	California (U.S.A.)
E-34	Italy
E-39	Austria
E-53	Spain

# PERIODIC MAINTENANCE AND TUNE-UP PROCEDURES

## CONTENTS

<b>PERIODIC MAINTENANCE SCHEDULE</b> .....	2- 1
<b>PERIODIC MAINTENANCE CHART</b> .....	2- 1
<b>LUBRICATION POINTS</b> .....	2- 2
<b>MAINTENANCE AND TUNE-UP PROCEDURES</b> .....	2- 3
<b>BATTERY</b> .....	2- 3
<b>CYLINDER HEAD NUTS &amp; EXHAUST PIPE BOLTS</b> .....	2- 4
<b>AIR CLEANER</b> .....	2- 5
<b>VALVE CLEARANCE</b> .....	2- 5
<b>SPARK PLUGS</b> .....	2- 7
<b>ENGINE OIL AND OIL FILTER</b> .....	2- 8
<b>FUEL LINES</b> .....	2- 9
<b>CARBURETORS</b> .....	2- 9
<b>CLUTCH</b> .....	2- 9
<b>DRIVE CHAIN</b> .....	2-11
<b>BRAKES</b> .....	2-12
<b>TIRES</b> .....	2-14
<b>STEERING</b> .....	2-15
<b>FRONT FORKS</b> .....	2-16
<b>REAR SUSPENSION</b> .....	2-16
<b>CHASSIS BOLTS AND NUTS</b> .....	2-17

## PERIODIC MAINTENANCE SCHEDULE

**IMPORTANT:** The periodic maintenance intervals and service requirements have been established in accordance with EPA regulations. Following these instructions will ensure that the motorcycle will not exceed emission standards and it will also ensure the reliability and performance of the motorcycle.

**NOTE:**

*More frequent servicing may be performed on motorcycles that are used under severe conditions however, it is not necessary for ensuring emission level compliance.*

The chart below lists the recommended intervals for all the required periodic service work necessary to keep the motorcycle operating at peak performance and economy. Mileages are expressed in terms of kilometer, miles and time for your convenience.

### PERIODIC MAINTENANCE CHART

Item	Interval	km	1000	6000	12000	18000	24000
		miles	600	4000	7500	11000	15000
		months	2	12	24	36	48
Battery			I	I	I	I	I
Cylinder head nuts & exhaust pipe bolts			T	T	T	T	T
Air cleaner		Clean every 3000 km (2000 miles) and replace every 12000 km (7500 miles)					
Valve clearance			I	I	I	I	I
Spark plugs			I	R	I	R	I
Fuel lines (Vapor hose ..... California model only)			Replace every four years				
Engine oil and filter			R	R	R	R	R
Carburetors (Idle rpm)			I	I	I	I	I
Clutch hose			Replace every four years				
Clutch fluid			Replace every two years				
Drive chain			Clean and lubricate every 1000km (600 miles)				
Brake hoses			Replace every four years				
Brake fluid			Replace every two years				
Brakes			I	I	I	I	I
Tires			I	I	I	I	I
Steering			I	I	I	I	I
Front fork			I	I	I	I	I
Rear suspension			I	I	I	I	I
Chassis bolts and nuts			T	T	T	T	T

**NOTE:** T = Tighten, I = Inspect, R = Replace

## LUBRICATION POINTS

Proper lubrication is important for smooth operation and long life of each working part of the motorcycle. Major lubrication points are indicated below.

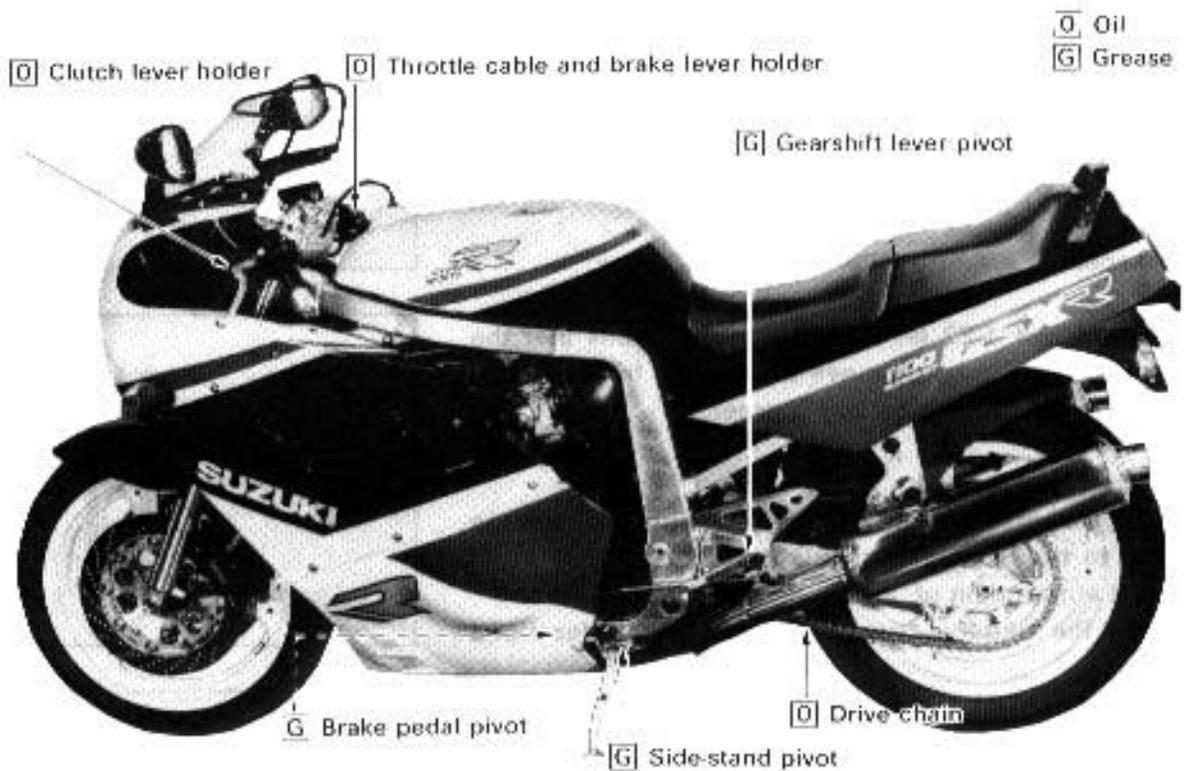

### NOTE:

- \* Before lubricating each part, clean off any rusty spots and wipe off any grease, oil, dirt or grime.
- \* Lubricate exposed parts which are subject to rust, with oil or grease.



## MAINTENANCE AND TUNE-UP PROCEDURES

This section describes the servicing procedures for each item of the Periodic Maintenance requirements.

### BATTERY

Inspect Every 6000 km (4000 miles, 12 months).

- Remove the seat and battery holder plate (1).
- Remove the battery (+) and (-) lead wires from the battery terminals.
- Remove the battery from its case.
- Check the electrolyte level and specific gravity. Add distilled water, as necessary, to keep the surface of the electrolyte above the MIN. level line but not above the MAX. level line.
- For checking specific gravity, use a hydrometer to determine the charged condition.

**09900-28403: Hydrometer**

**Standard specific gravity: 1.28 at 20°C (68°F)**

An S.G. reading of 1.22 (at 20°C) or under means that the battery needs recharging. Remove the battery from the machine and charge it with a battery charger.

#### CAUTION:

**Never charge a battery while still in the machine as damage may result to the battery or regulator/rectifier.**

- Charge at a maximum of 1.4 amps.
- To install the battery, reverse the procedure described above.

#### WARNING:

**When installing the battery lead wires, fix the (+) lead first and (-) lead last.**

- Make sure that the breather hose is tightly secured and undamaged, and is routed as shown in the figure.

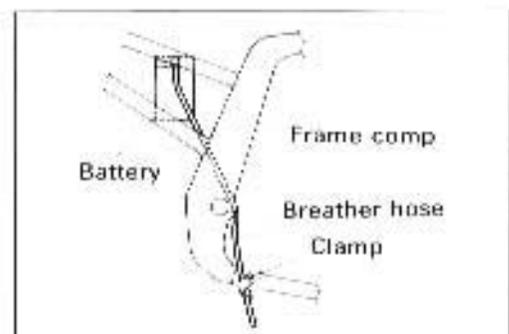
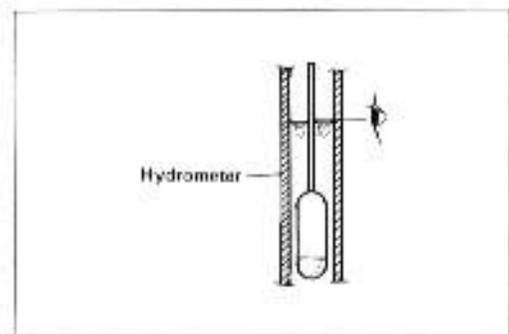
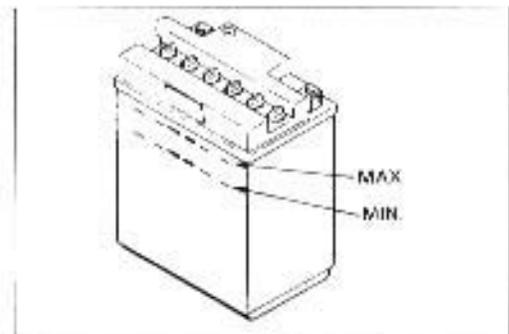
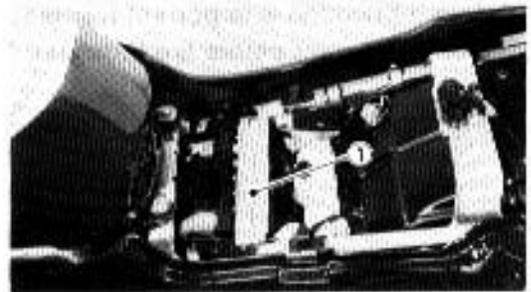

## CYLINDER HEAD NUTS AND EXHAUST PIPE BOLTS

**Tighten Initially at 1000 km (600 miles, 2 months) and Every 6000 km (4000 miles, 12 months) thereafter.**

### CYLINDER HEAD

- Remove the seat, fairings and fuel tank. (Refer to page 3-4.)
- Remove the cylinder head cover.
- First, loosen and retighten the nuts to the specified torque with a torque wrench sequentially in ascending numerical order with the engine cold.

**Cylinder head nut: 35 – 40N·m  
(3.5 – 4.0 kg·m, 25.5 – 29.0 lb-ft)**

- After firmly tightening the 12 nuts, tighten the bolt and nut (indicated as (A) and (B)) to the torque value below:

**Cylinder head bolt (A): 8 – 12 N·m  
(0.8 – 1.2 kg·m, 6.0 – 8.5 lb-ft)**

**Cylinder nut (B): 7 – 11 N·m  
(0.7 – 1.1 kg·m, 5.0 – 8.0 lb-ft)**

- When installing the cylinder head cover, apply SUZUKI BOND NO. 1207B to the head cover groove and cam end caps. (Refer to page 3-68.)
- Tighten the head cover bolts to the specified torque.

**Tightening torque: 13 – 15 N·m  
(1.3 – 1.5kg·m, 9.5 – 11.0 lb-ft)**

### EXHAUST PIPE

- Tighten the exhaust pipe clamp bolts to the specified torque with a torque wrench.

**Exhaust pipe clamp bolt: 18 – 28 N·m  
(1.8 – 2.8kg·m, 13.0 – 20.0 lb-ft)**

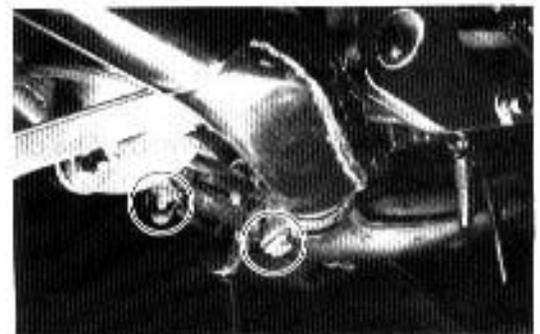
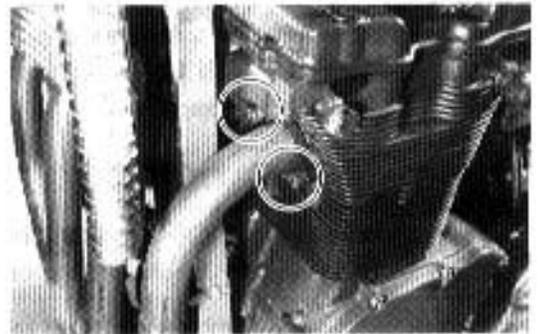
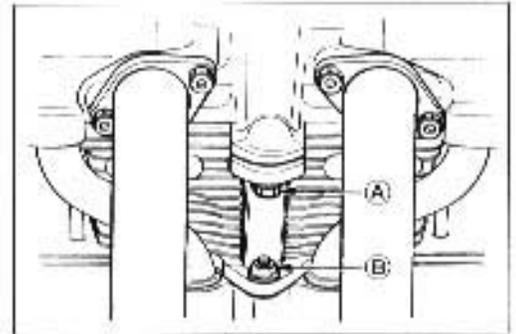
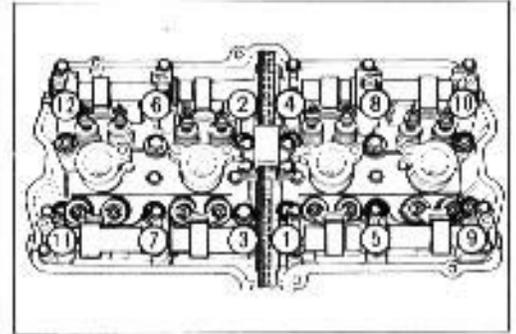

## AIR CLEANER

**Clean Every 3000 km (2000 miles) and Replace Every 12000 km (7500 miles).**

- Remove both seats.
  - Remove both frame covers.
  - Remove the battery.
  - Remove the battery holder by removing the ignitor unit.
  - Remove the air cleaner element by removing the screws.
- Carefully use air hose to blow the dust from the cleaner element.

### CAUTION:

Always use air pressure on the outside of the cleaner element. If air pressure is used on the inside, dirt will be forced into the pores of the cleaner element thus restricting air flow through the cleaner element.

- Reinstall the cleaned or new cleaner element in the reverse order of removal.
- When installing the air cleaner element in the cleaner case, make sure that the part number (A) comes upward.

### CAUTION:

If driving under dusty conditions, clean the air cleaner element more frequently. The surest way to accelerate engine wear is to use the engine without the element or to use a ruptured element. Make sure that the air cleaner is in good condition at all times. Life of the engine depends largely on this component!

## VALVE CLEARANCE

**Inspect Initially at 1000 km (600 miles, 2 months) and Every 6000 km (4000 miles, 12 months) thereafter.**

- Remove the seat, fairings and fuel tank.
- Remove the cylinder head cover.

The valve clearance specification is different for both intake and exhaust valves.

Valve clearance adjustment must be checked and adjusted. 1) at the time of periodic inspection, 2) when the valve mechanism is serviced, and 3) when the camshafts are disturbed by removing them for servicing.

**Valve clearance (when cold): IN. 0.10 – 0.15 mm (0.004 – 0.006 in)  
EX. 0.18 – 0.23 mm (0.007 – 0.009 in)**

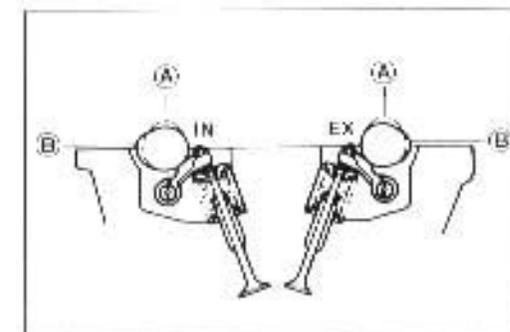
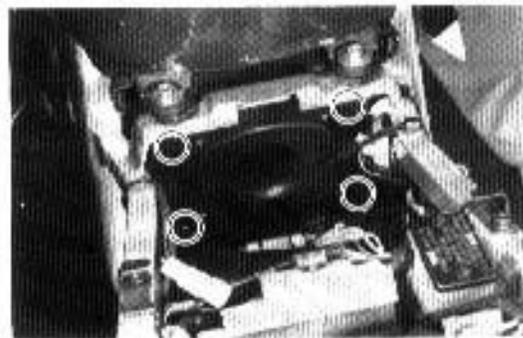

**NOTE:**

- \* The cam must be at positions (A) or (B), in order to check the valve clearance, or to adjust valve clearance. Clearance readings should not be taken with the cam in any other position than these two positions.
- \* The clearance specification is for COLD state.
- \* To turn the crankshaft for clearance checking, be sure to use a 19-mm wrench, and rotate in the normal running direction. All spark plugs should be removed.

- Turn crankshaft to bring the "T" mark on the rotor to the center of pick-up coil and also to bring the notches (C) in the right ends of both camshafts (Ex and In) to the positions shown. In this condition, read the valve clearance at the valves (D) (In and Ex of No. 1 cylinder, Ex of No. 2 and In of No. 3).

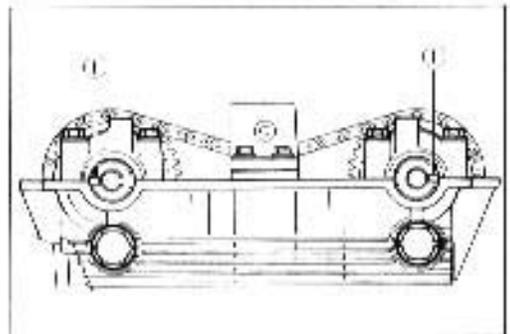
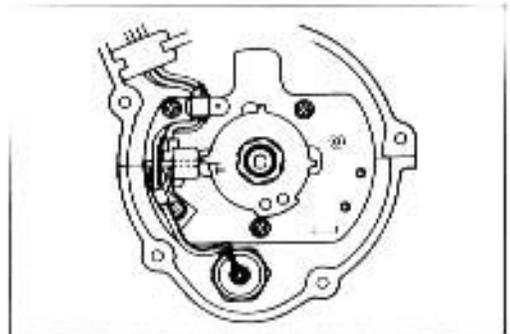
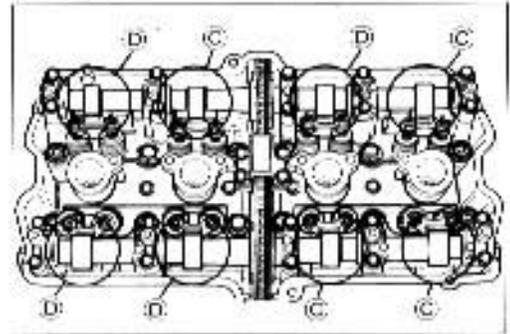

- Use a thickness gauge between the adjusting screw and the valve stem end. If the clearance is out of specification, bring it into the specified range by using the special tool.

09900-20803: Thickness gauge

09917-14910: Valve adjust driver

**CAUTION:**

**Both right and left valve clearances should be as closely set as possible.**

- Turn the crankshaft 360° (one rotation) to bring the "T" mark on the rotor to the center of pick-up coil and also to bring the notches (C) to the positions shown.
- Read the clearance at the remaining valves (D) and adjust the clearance if necessary.

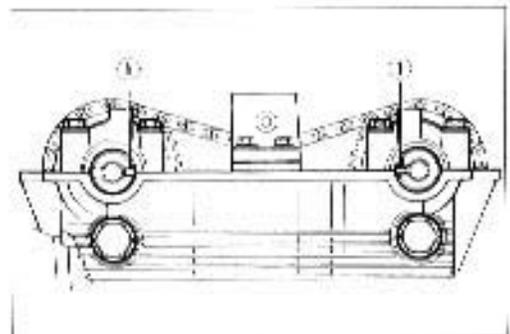
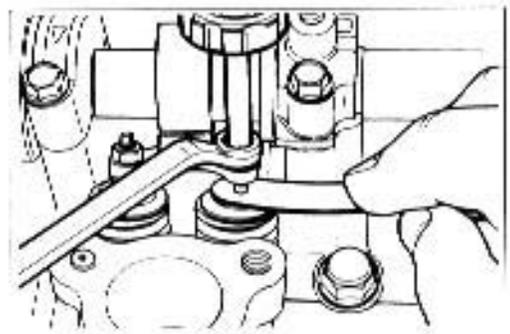

Cam Position	Notch  position	
	Intake Camshaft	Exhaust Camshaft
		
		

- When installing the cylinder head cover, apply SUZUKI BOND NO. 1207B to the head cover groove and cam end caps. (Refer to page 3-68.)
- Tighten the head cover bolts and union bolts to the specified torque.  
(Refer to page 3-68.)

## SPARK PLUGS

Inspect at 6000 km (4000 miles, 12 months), 18000 km (11000 miles, 36 months) and Replace Every 12000 km (7500 miles, 24 months).

- Remove the seat, fairings and fuel tank.
- Remove the spark plugs with the spark plug wrench.

### CAUTION:

Take care not to damage the fuel hoses when raising the fuel tank.

The plug gap is adjusted to 0.6 – 0.7 mm (0.02 – 0.03 in). The gap is correctly adjusted by using a thickness gauge. When carbon is deposited on the spark plug, remove the carbon with a spark plug cleaning machine or by carefully using a tool with a pointed end. If the electrode is extremely worn or burnt, replace the plug. Also replace the plug if it has a broken insulator, damaged thread, etc.

NGK JR9B as listed in the table should be used as the standard plug. However, the heat range of the plug should be selected to meet the requirements of speed, actual load, fuel, etc. If the plugs need to be replaced, it is recommended that plugs having a heat range closest to the standard plug in the table be selected. Remove the plugs and inspect the insulators. Proper heat range would be indicated if all insulators are light brown in color. If they are baked white, they should be replaced by a cold type NGK JR10B.

### Recommended spark plug

	Standard	Cold type
NGK	JR9B	JR10B

09930-13210: Spark plug socket wrench

09930-14530: Universal joint

09914-24510: T handle

09900-20803: Thickness gauge

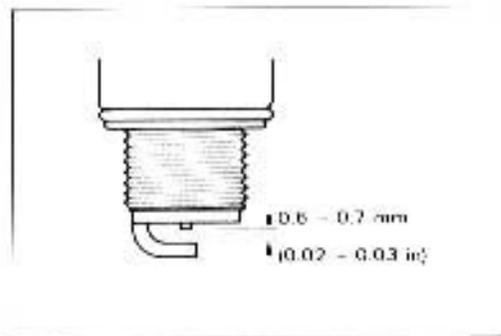
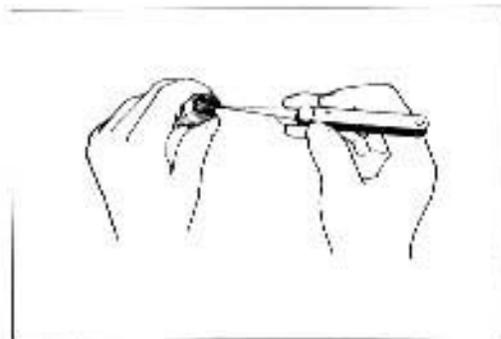

### CAUTION:

Confirm the thread size and reach when replacing the plug. If the reach is too short, carbon will be deposited on the screw portion of the plug hole and engine damage may result.

### NOTE:

"R" type spark plug is installed for some specifications. "R" type spark plug has a resistor located at the center electrode to prevent radio noise.

## ENGINE OIL AND OIL FILTER

**Replace Initially at 1000 km (600 miles, 2 months) and Every 6000 km (4000 miles, 12 months) thereafter.**

Oil should be changed while the engine is hot. Oil filter replacement at the above intervals, should be done together with the engine oil change.

- Keep the motorcycle upright.
- Place an oil pan below the engine, and drain oil by removing the drain plug ① and filler cap ②.
- Remove the oil filter ③ by using the oil filter wrench. (Special tool ④)
- Apply engine oil lightly to the gasket of the new filter before installation.
- Install the new filter turning it by hand until you feel that the filter gasket contacts the mounting surface. Then tighten it 2 turns using the oil filter wrench. (Special tool ④)

### 09915-40610: Oil filter wrench

#### NOTE:

To properly tighten the filter, use the special tool. Never tighten the filter by hand.

- Fit the drain plug ① securely, and add fresh oil through the oil filler. The engine will hold about 4.5 L (4.8 US qt) of oil. Use an API classification of SE or SF oil with SAE 10W/40 viscosity.
- Start up the engine and allow it to run for several seconds at idling speed.
- Turn off the engine and wait about one minute, then check the oil level through the inspection window ④. If the level is below mark "F", add oil to that level.

### NECESSARY AMOUNT OF ENGINE OIL

Oil change: 4.0 L (4.2/3.5 US/Imp qt)

Filter change: 4.2 L (4.4/3.7 US/Imp qt)

Overhaul engine: 5.1 L (5.4/4.5 US/Imp qt)

#### CAUTION:

Use **SUZUKI MOTORCYCLE GENUINE OIL FILTER** only, since the other make's genuine filters and after-market parts may differ in thread specifications (thread diameter and pitch), filtering performance and durability, which could cause engine damage or oil leaks. Suzuki automobile genuine oil filter is also not usable for the motorcycles.

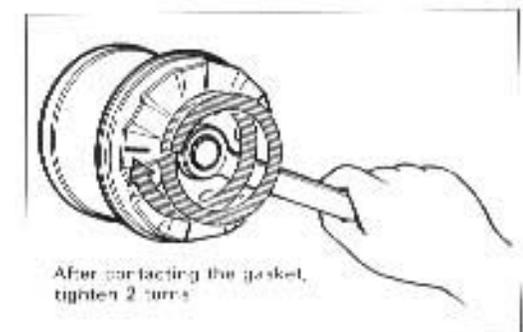
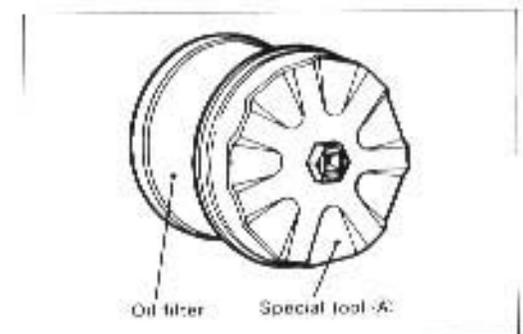
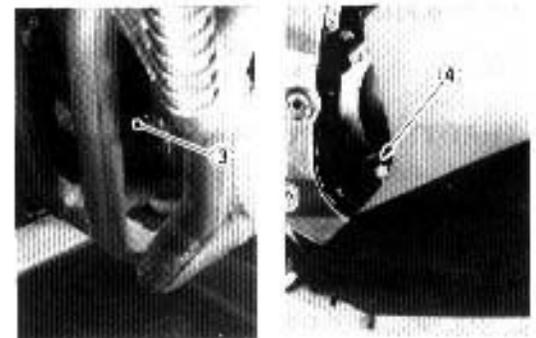
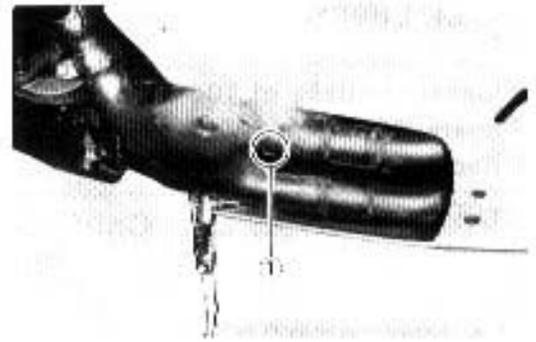

## FUEL LINES

Inspect Initially at 1000 km (600 miles, 2 months) and Every 6000 km (4000 miles, 12 months) thereafter. Replace Every four years.

**VAPOR HOSE** ..... California model only

## CARBURETORS

### IDLE RPM (Idling adjustment)

Inspect Initially at 1000 km (600 miles, 2 months) and Every 6000 km (4000 miles, 12 months) thereafter.

#### NOTE:

Make this adjustment when the engine is hot.

- Connect a tachometer.
- Start up the engine and set its speed at anywhere between 1000 and 1200 r/min by turning throttle stop screw (1).

Engine idle speed: **1100 ± 100 r/min** ..... for E-01 and others  
**1200 ± 100 r/min** ..... for E-03 (Except California)  
**1100  $\pm$   $\frac{100}{50}$  r/min** ..... for E-18

### THROTTLE CABLE PLAY

There should be 0.5 – 1.0 mm (0.02 – 0.04 in) play (A) in the throttle cable. Adjust the throttle cable play with the following procedures.

- Loosen the lock nut (1) and turn the adjuster (2) in or out until the specified play is obtained.
- Tighten the lock nut (1) while holding the adjuster.

Throttle cable play (A): **0.5 – 1.0mm (0.02 – 0.04in)**

#### WARNING:

After the adjustment is completed, check that handlebar movement does not raise the engine idle speed, and that the throttle grip returns smoothly and automatically.

## CLUTCH

Inspect Initially at 1000 km (600 miles, 2 months) and Every 6000 km (4000 miles, 12 months) thereafter. Replace hose every four years. Replace fluid every two years.

### CLUTCH FLUID LEVEL

- Keep the motorcycle upright and place the handlebars straight.
- Check the clutch fluid level in the reservoir.
- If the level is found to be lower than the lower mark, replenish with BRAKE FLUID that meets the following specification.

Specification and classification : **DOT4**

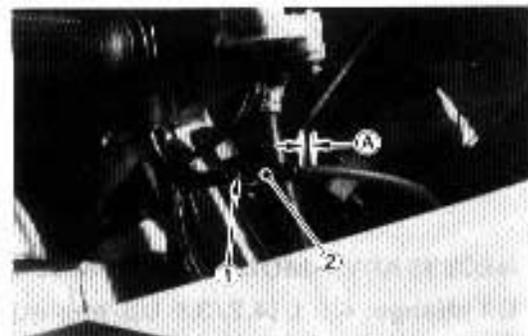
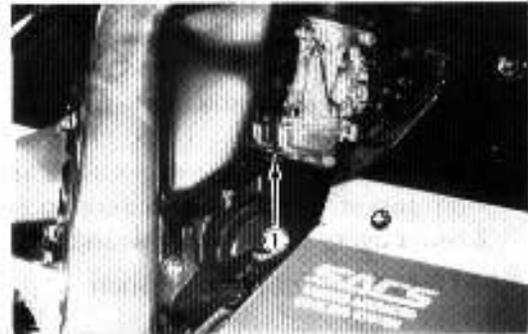

**WARNING:**

The clutch system of this motorcycle is filled with a glycol-based brake fluid. Do not use or mix different types of fluid such as silicone-based and petroleum-based. Do not use any brake fluid taken from old, used or unsealed containers. Never re-use brake fluid left over from the last servicing or stored for long periods.

**BLEEDING AIR FROM THE CLUTCH FLUID CIRCUIT**

The clutch fluid circuit may be purged of air in the following manner.

- Remove the lower fairing.
- Keep the motorcycle upright and place the handlebars straight.
- Fill up the master cylinder reservoir to the upper end of the inspection window. Replace the reservoir cap to prevent entry of dirt.
- Attach a pipe to the bleeder valve and insert the free end of the pipe into a receptacle.
- Squeeze and release the clutch lever several times in rapid succession, and squeeze the lever fully without releasing it. Loosen the bleeder valve by turning it a quarter of a turn so that the fluid runs into the receptacle; this will remove the tension of the clutch lever causing it to touch the handlebar grip. Then, close the valve, pump and squeeze the lever, and open the valve. Repeat this process until the fluid flowing into the receptacle no longer contains air bubbles.

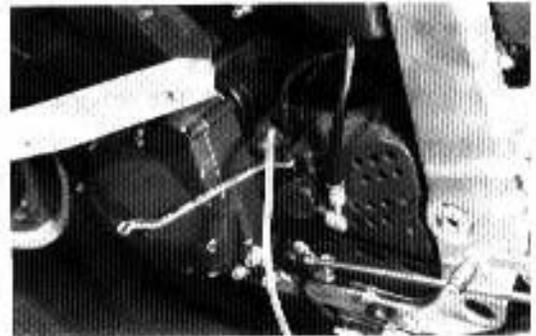
**NOTE:**

*Replenish the clutch fluid in the reservoir as necessary while bleeding the clutch system. Make sure that there is always some fluid visible in the reservoir.*

- Close the bleeder valve, and disconnect the pipe. Fill the reservoir to the upper end of the inspection window.

**Bleeder valve**

tightening torque: 6 – 9 N·m

(0.6 – 0.9kg-m, 4.5 – 6.5 lb-ft)

**CAUTION:**

Handle brake fluid with care: the fluid reacts chemically with paint, plastics, rubber materials, etc.



## DRIVE CHAIN

**Inspect Initially at 1000 km (600 miles, 2 months) and Every 6000 km (4000 miles, 12 months) thereafter. Clean and Lubricate Every 1000 km (600 miles).**

Visually check the drive chain for the possible defects listed below. (Support the motorcycle by a jack and a wooden block, turn the rear wheel slowly by hand with the transmission shifted to Neutral.)

- \* Loose pins
- \* Excessive wear
- \* Damaged rollers
- \* Improper chain adjustment
- \* Dry or rusted links
- \* Missing O-ring seals
- \* Kinked or binding links

If any defects are found, the drive chain must be replaced.

### CHECKING

- Place the motorcycle on the side-stand.
- Loosen the axle nut ①.
- Tense the drive chain fully by turning both chain adjusters ②.
- Count out 21 pins (20 pitches) on the chain and measure the distance between the two points. If the distance exceeds the following limit, the chain must be replaced.

**Service Limit: 319.4mm(12.6in)**

### ADJUSTING

- Loosen or tighten both chain adjusters ③ until the chain has 25 – 30 mm (1.0 – 1.2 in) of slack in the middle between engine and rear sprockets. The mark ③ on both chain adjusters must be at the same position on the scale to ensure that the front and rear wheels are correctly aligned. Place the motorcycle on its side-stand for accurate adjustment.
- After adjusting the drive chain slack, tighten the axle nut securely.
- Tighten both chain adjusters ② securely.

### Rear axle nut

**Tightening torque: 85 – 115 N·m  
(8.5 – 11.5 kg·m, 61.5 – 83.0 lb·ft)**

### CLEANING AND LUBRICATING

- Wash the chain with kerosene. If the chain tends to rust quickly, the intervals must be shortened.

### CAUTION:

Do not use trichlene, gasoline or any similar fluids: These fluids have too great a dissolving power for this chain and, what is more important, they can damage the "O" rings (or seals) confining the grease in the bush to pin clearance. Remember, high durability comes from the presence of grease in that clearance.

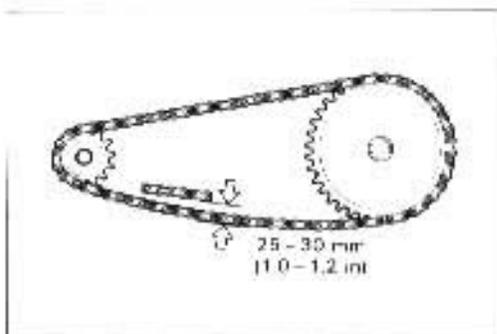
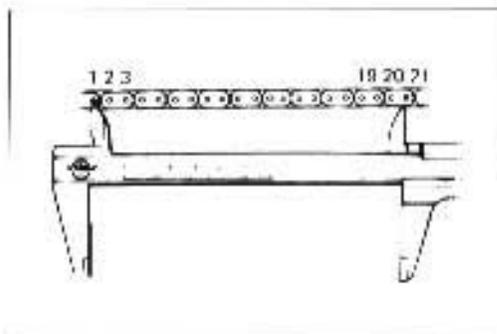
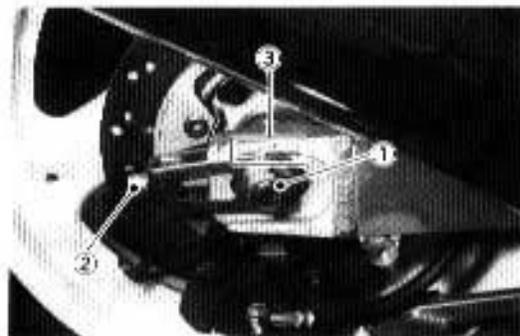
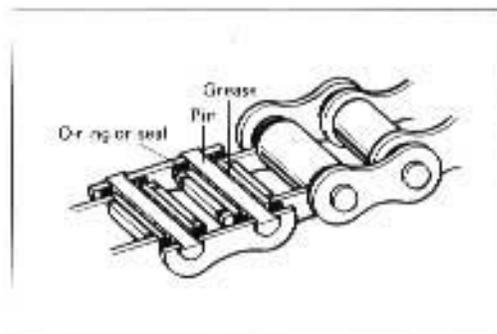

- After washing and drying the chain, oil it with a heavy-weight motor oil.

**CAUTION:**

Do not use any oil sold commercially as "drive chain oil". Such oil can damage the "O" rings (or seals).

The standard drive chain TAKASAGO RK532GSV. SUZUKI recommends that the above-mentioned standard drive chain be used for the replacement.

**BRAKES**

Inspect Initially at 1000 km (600 miles, 2 months) and Every 6000 km. (4000 miles, 12 months) thereafter. Replace hoses Every four years. Change fluid Every two years.

**BRAKE FLUID LEVEL**

- Keep the motorcycle upright and place the handlebars straight.
- Remove the seat.
- Check the brake fluid level by observing the upper (Only for rear brake) and lower (Both front and rear brakes) limit lines on the brake fluid reservoirs.
- When the level is below the lower limit line, replenish with brake fluid that meets the following specification.

**Specification and Classification: DOT4**

**WARNING:**

The brake system of this motorcycle is filled with a glycol-based brake fluid. Do not use or mix different types of fluid such as silicone-based or petroleum-based. Do not use any brake fluid taken from old, used or unsealed containers. Never re-use brake fluid left over from the last servicing or stored for a long period.

**WARNING:**

Brake fluid, if it leaks, will interfere with safe running and immediately discolor painted surfaces. Check the brake hoses and hose joints for cracks and oil leakage before riding.

**BRAKE PADS**

The extent of brake pad wear can be checked by observing the grooved limit line (○) on the pad. When the wear exceeds the grooved limit line, replace the pads with new ones. (Refer to pages 6-7 and 6-24.)

**CAUTION:**

Replace the brake pad as a set, otherwise braking performance will be adversely affected.

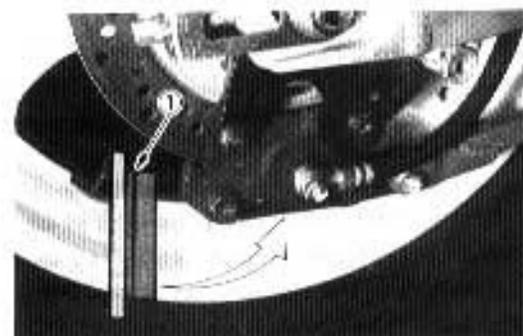
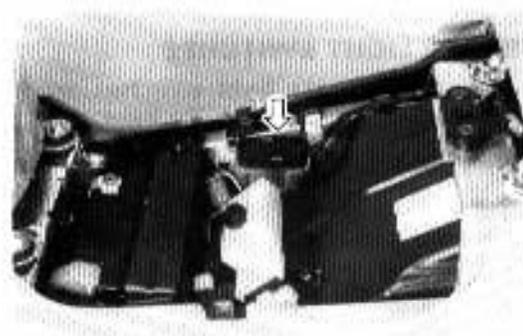
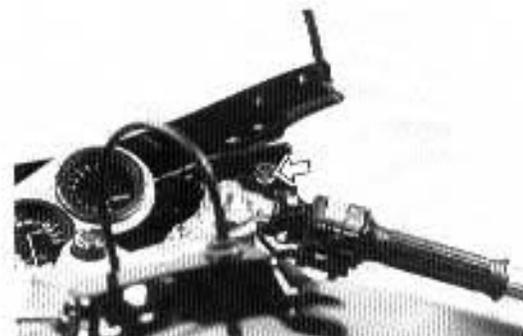

**BRAKE PEDAL HEIGHT**

- Loosen the lock nut ① and rotate the push rod ② to locate brake pedal 65 mm (2.6 in) ③ below the top face of the footrest.
- Retighten the lock nut ① to secure the push rod ② in the proper position.

**Brake pedal height ③: 65 mm (2.6 in)**

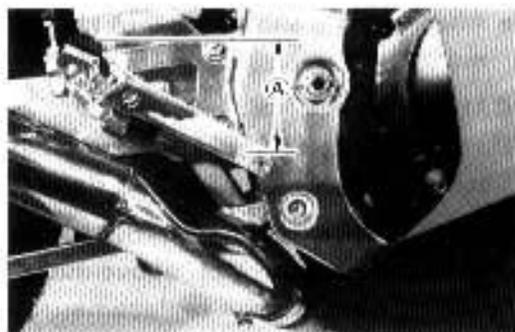
**BRAKE LIGHT SWITCHES**

Adjust both brake light switches, front and rear, so that the brake light will come on just before pressure is felt when the brake lever is squeezed, or the brake pedal is depressed.

**AIR BLEEDING THE BRAKE FLUID CIRCUIT**

Air trapped in the fluid circuit acts like a cushion to absorb a large proportion of the pressure developed by the master cylinder and thus interferes with the full braking performance of the brake caliper. The presence of air is indicated by "sponginess" of the brake lever and also by lack of braking force. Considering the danger to which such trapped air exposes the machine and rider, it is essential that, after remounting the brake and restoring the brake system to the normal condition, the brake fluid circuit be purged of air in the following manner:

- Fill up the master cylinder reservoir to the upper end of the inspection window, (for front brake) and "UPPER" line. (for rear brake) Replace the reservoir cap to prevent entry of dirt.
- Attach a pipe to the caliper bleeder valve, and insert the free end of the pipe into a receptacle.

**Bleeder valve tightening torque: 6 – 9 N-m  
(0.6 – 0.9 kg-m, 4.5 – 6.5 lb-ft)**

- Front brake: Bleed the air from the inboard valve first, and then outboard valve.
- Squeeze and release the brake lever several times in rapid succession and squeeze the lever fully without releasing it. Loosen the bleeder valve by turning it a quarter of a turn so that the brake fluid runs into the receptacle; this will remove the tension of the brake lever causing it to touch the handlebar grip. Then, close the valve, pump and squeeze the lever, and open the valve. Repeat this process until the fluid flowing into the receptacle no longer contains air bubbles.

**NOTE:**

*Replenish the brake fluid in the reservoir as necessary while bleeding the brake system. Make sure that there is always some fluid visible in the reservoir.*

- Close the bleeder valve, and disconnect the pipe. Fill the reservoir to the upper end of the inspection window (for front brake) and "UPPER" line. (for rear brake)

**CAUTION:**

**Handle brake fluid with care: the fluid reacts chemically with paint, plastics, rubber materials etc.**

- The only difference between bleeding the front and rear brakes is that the rear master cylinder is actuated by a pedal.

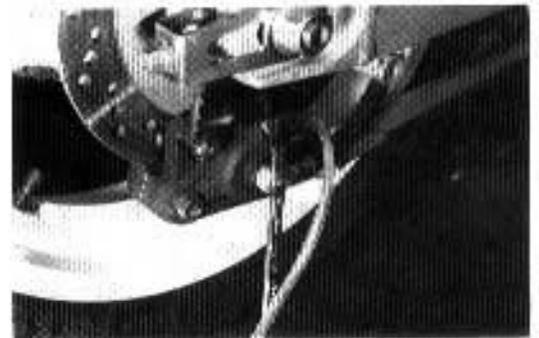

## TIRES

**Inspect Initially at 1000 km (600 miles, 2 months) and Every 6000 km (4000 miles, 12 months) thereafter.**

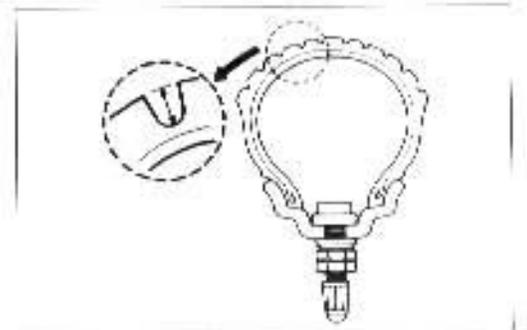

### TIRE TREAD CONDITION

Operating the motorcycle with excessively worn tires will decrease riding stability and consequently invite a dangerous situation. It is highly recommended to replace a tire when the remaining depth of tire tread reaches the following specification.

Tire tread depth limit: **FRONT 1.6 mm (0.06 in)**  
**REAR 2.0 mm (0.08 in)**

### TIRE PRESSURE

If the tire pressure is too high or too low, steering will be adversely affected and tire wear increased. Therefore, maintain the correct tire pressure for good roadability or shorter tire life will result. Cold inflation tire pressure is as follows.

COLD INFLATION TIRE PRESSURE	SOLD RIDING			DUAL RIDING		
	kPa	kg/cm <sup>2</sup>	psi	kPa	kg/cm <sup>2</sup>	psi
FRONT	230	2.30	33	250	2.50	36
REAR	250	2.50	36	290	2.90	42

#### CAUTION:

The standard tire fitted on this motorcycle is **120/70 ZR17** for front (**MICHELIN A59**) and **160/60 ZR17** for rear (**MICHELIN M59**). The use of tires other than those specified may cause instability. It is highly recommended to use a **SUZUKI Genuine Tire**.

### STEERING

Inspect initially at 1000 km (600 miles, 2 months) and Every 6000 km (4000 miles, 12 months) thereafter.

Taper roller type bearings are used in the steering system for better handling. Steering should be adjusted properly for smooth turning of handlebars. Overtight steering prevents smooth turning of the handlebars and too loose steering will cause poor stability. Check that there is no play in the front fork assembly by supporting the machine so that the front wheel is off the ground, with the wheel straight ahead, grasp the lower fork tubes near the axle and pull forward. If play is found, perform steering bearing adjustment as described on page 6-19 of this manual.

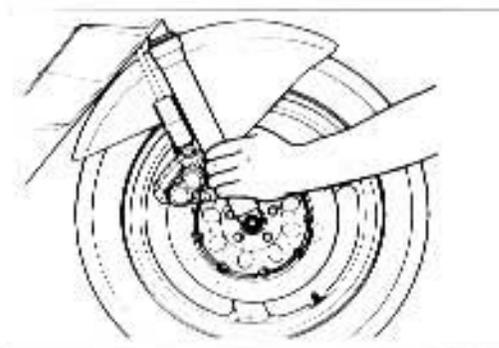
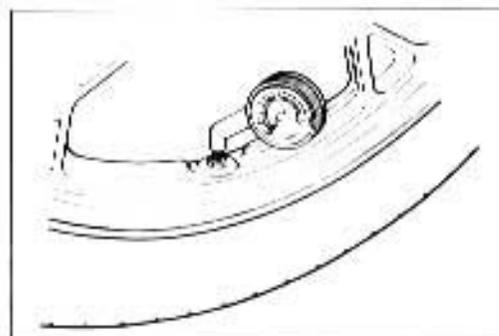

## FRONT FORKS

**Inspect Initially at 1000 km (600 miles, 2 months) and Every 12000 km (7500 miles, 24 months) thereafter.**

Inspect the front forks for oil leakage, scoring or scratches on the outer surface of the inner tubes. Replace any defective parts, if necessary. (Refer to page 6-12.)

## REAR SUSPENSION

**Inspect Initially at 1000 km (600 miles, 2 months) and Every 12000 km (7500 miles, 24 months) thereafter.**

Inspect the rear shock absorber for oil leakage and check that there is no play in the swingarm assembly.

## CHASSIS BOLTS AND NUTS

**Tighten Initially at 1000 km (600 miles, 2 months) and Every 6000 km (4000 miles, 12 months) thereafter.**

The nuts and bolts listed below are important safety related parts. They must be retightened when necessary to the specified torque with a torque wrench. (Refer to page 2-18 for the locations of the following nuts and bolts on the motorcycle.)

ITEM	N-m	kg-m	lb-ft
① Steering stem head nut	50 - 80	5.0 - 8.0	36.0 - 58.0
② Front fork upper clamp bolt	22 - 35	2.2 - 3.5	16.0 - 25.5
③ Front fork lower clamp bolt	22 - 35	2.2 - 3.5	16.0 - 25.5
④ Front fork cap bolt	15 - 30	1.5 - 3.0	11.0 - 21.5
⑤ Front fork damper rod bolt	34 - 46	3.4 - 4.6	24.5 - 33.5
⑥ Front axle	85 - 115	8.5 - 11.5	61.5 - 83.0
⑦ Front axle pinch bolt	18 - 28	1.8 - 2.8	13.0 - 20.0
⑧ Handlebar holder mounting bolt	50 - 60	5.0 - 6.0	36.0 - 43.5
⑨ Handlebar holder mounting nut	22 - 35	2.2 - 3.5	16.0 - 25.5
⑩ Clutch master cylinder mounting bolt	5 - 8	0.5 - 0.8	3.5 - 6.0
⑪ Front brake caliper mounting bolt	27 - 43	2.7 - 4.3	19.5 - 31.0
⑫ Front brake caliper housing bolt	20 - 25	2.0 - 2.5	14.5 - 18.0
⑬ Front brake pad mounting bolt	15 - 20	1.5 - 2.0	11.0 - 14.5
⑭ Front brake master cylinder mounting bolt	5 - 8	0.5 - 0.8	3.5 - 6.0
⑮ Brake and clutch hose union bolt (Cylinder & Caliper)	20 - 25	2.0 - 2.5	14.5 - 18.0
⑯ Air bleeder valve (Front & Rear)	6 - 9	0.6 - 0.9	4.5 - 6.5
⑰ Front and rear disc bolt	15 - 25	1.5 - 2.5	11.0 - 18.0
⑱ Front footrest bracket mounting bolt	27 - 43	2.7 - 4.3	19.5 - 31.0
⑲ Swingarm pivot nut	85 - 115	8.5 - 11.5	61.5 - 83.0
⑳ Front footrest nut	35 - 55	3.5 - 5.5	25.5 - 40.0
㉑ Rear shock absorber mounting nut (Upper & Lower)	40 - 60	4.0 - 6.0	29.0 - 43.5
㉒ Rear cushion level/rod mounting nut	110 - 160	11.0 - 16.0	79.5 - 115.5
㉓ Rear brake caliper mounting bolt	18 - 28	1.8 - 2.8	13.0 - 20.0
㉔ Rear brake caliper housing bolt	30 - 36	3.0 - 3.6	21.5 - 24.5
㉕ Rear torque link nut (Front & Rear)	22 - 34	2.2 - 3.4	16.0 - 24.5
	For E-03, 28 and 33	1.8 - 2.8	13.0 - 20.0
㉖ Rear brake master cylinder mounting bolt	18 - 28	1.8 - 2.8	13.0 - 20.0
㉗ Rear brake rod lock nut	18 - 28	1.8 - 2.8	13.0 - 20.0
㉘ Rear axle nut	85 - 115	8.5 - 11.5	61.5 - 83.0
㉙ Rear sprocket nut	48 - 72	4.8 - 7.2	35.0 - 52.0

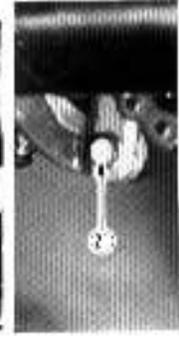
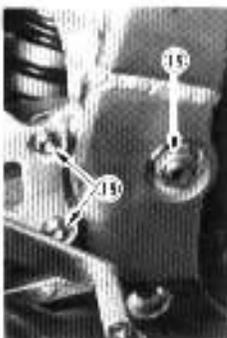
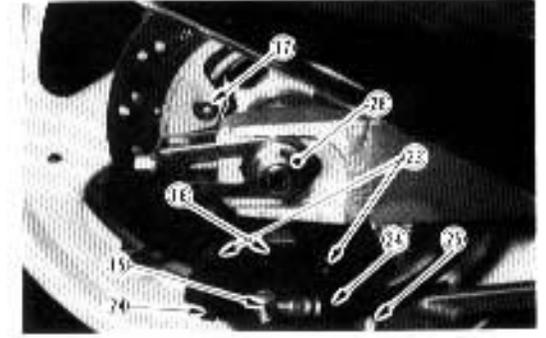
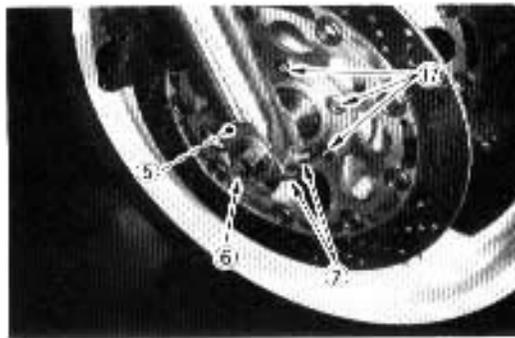
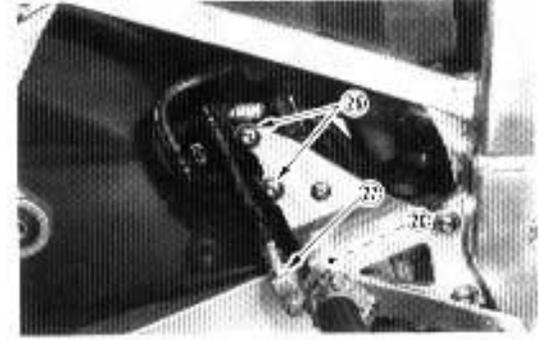
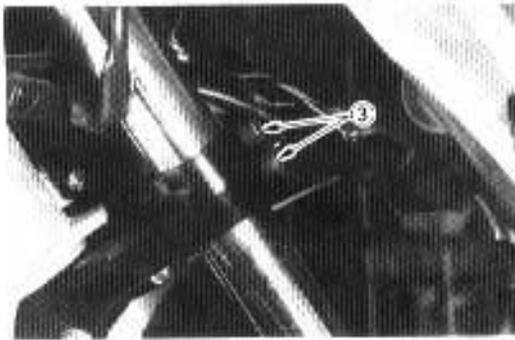
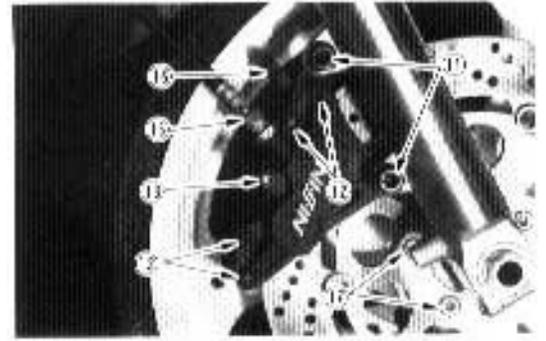
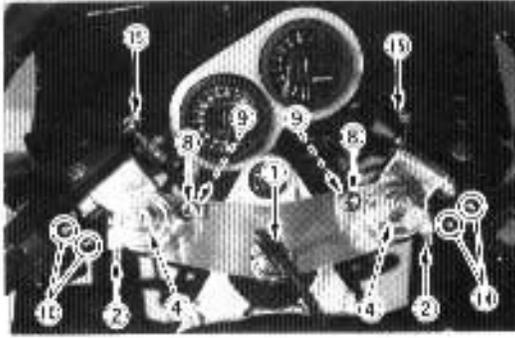



## CONTENTS

<i>COMPRESSION CHECK</i> .....	3- 1
<i>OIL PRESSURE CHECK</i> .....	3- 2
<i>ENGINE COMPONENTS REMOVABLE WITH THE ENGINE IN PLACE</i> .....	3- 3
<i>ENGINE REMOVAL AND REINSTALLATION</i> .....	3- 4
<i>ENGINE DISASSEMBLY</i> .....	3-13
<i>ENGINE COMPONENTS INSPECTION AND SERVICING</i> .....	3-24
<i>CYLINDER HEAD</i> .....	3-24
<i>VALVE</i> .....	3-25
<i>CAMSHAFT</i> .....	3-31
<i>CAM CHAIN TENSIONER</i> .....	3-33
<i>CYLINDER</i> .....	3-34
<i>PISTON</i> .....	3-35
<i>PISTON RING</i> .....	3-36
<i>CRANKCASE</i> .....	3-40
<i>CRANKSHAFT</i> .....	3-42
<i>CLUTCH</i> .....	3-44
<i>OIL PUMP</i> .....	3-45
<i>TRANSMISSION GEARS</i> .....	3-46
<i>ENGINE REASSEMBLY</i> .....	3-51
<i>CRANKCASE</i> .....	3-54
<i>CLUTCH</i> .....	3-57
<i>SIGNAL GENERATOR</i> .....	3-58
<i>STARTER CLUTCH</i> .....	3-59
<i>PISTON AND RING</i> .....	3-61
<i>CYLINDER</i> .....	3-62
<i>CAMSHAFT</i> .....	3-64

## COMPRESSION CHECK

The compression of a cylinder is a good indicator of its internal condition. The decision to overhaul the cylinders is often based on the results of a compression test. Periodic maintenance records kept at your dealership should include compression readings for each maintenance service.

### COMPRESSION

Standard	Limit	Difference
1200 – 1400 kPa (12 – 14 kg/cm <sup>2</sup> ) (170 – 199 psi)	1000 kPa (10 kg/cm <sup>2</sup> ) (142 psi)	200 kPa (2 kg/cm <sup>2</sup> ) (28 psi)

**Low compression pressure can indicate any of the following conditions:**

- \* Excessively worn cylinder wall
- \* Worn-down piston or piston rings
- \* Piston rings stuck in grooves
- \* Poor seating of valves
- \* Ruptured or otherwise defective cylinder head gasket

**Overhaul the engine in the following cases:**

- \* Compression pressure in one of the cylinders is less than 1000 kPa (10 kg/cm<sup>2</sup>, 142 psi).
- \* Difference in compression pressure between any two cylinders is more than 200 kPa (2 kg/cm<sup>2</sup>, 28 psi).
- \* All compression pressure are below 1200 kPa (12 kg/cm<sup>2</sup>, 170 psi) (standard) even when they measure more than 1000 kPa (10 kg/cm<sup>2</sup>, 142 psi).

## COMPRESSION TEST PROCEDURE

### NOTE:

- \* *Before testing the engine for compression pressure, make sure that the cylinder head nuts and bolt are tightened to the specified torque values and valves are properly adjusted.*
- \* *Warm up the engine before testing.*

- Remove the seat, fairings and fuel tank.
- Remove all the spark plugs.
- Fit the compression gauge ① in one of the plug holes, while taking care that the connection is tight.
- Twist the throttle grip full-open.
- Crank the engine a few seconds with the starter, and record the maximum gauge reading as the compression of that cylinder.
- Repeat this procedure with the other cylinders.

**09915-64510: Compression gauge**

**09915-63210: Adaptor**

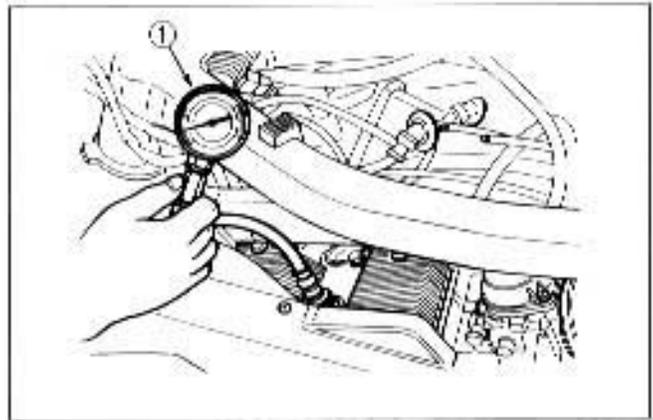

## OIL PRESSURE CHECK

To check periodically oil pressure of the oil passage way in the engine needs to judge roughly the conditions of the moving parts.

### OIL PRESSURE SPECIFICATION

**Above 300 kPa (3.0 kg/cm<sup>2</sup>, 43 psi)**  
**Below 600 kPa (6.0 kg/cm<sup>2</sup>, 85 psi)** at 3 000 r/min., Oil temp. at 60°C (140°F)

If the oil pressure is lower or higher than the specification, the following causes may be considered.

#### LOW OIL PRESSURE

- \* Clogged oil filter
- \* Oil leakage from the oil passage way
- \* Damaged oil seal
- \* Defective oil pump
- \* Combination of above items

#### HIGH OIL PRESSURE

- \* Used a engine oil which is too heavy a weight
- \* Clogged oil passage way
- \* Combination of above items

### OIL PRESSURE TEST PROCEDURE

Start the engine and check if the oil pressure indicator light is turned on. If it keeps on lighting, check the oil pressure indicator light circuit. If it is in good condition, check the oil pressure in the following manner.

- Remove the lower fairing.
- Install the oil pressure gauge with adaptor ① in the position shown in the figure.
- Warm up the engine as follows:  
 Summer 10 min. at 2 000 r/min.  
 Winter 20 min. at 2 000 r/min.
- After warming up, increase the engine speed to 3 000 r/min. with the engine tachometer reading, and read the oil pressure gauge.

**09915-74510: Oil pressure gauge**

**09915-74540: Adaptor**

**09915-77330: Meter (for high pressure)**

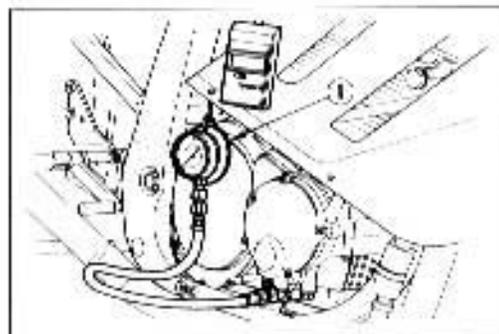

## ENGINE COMPONENTS REMOVABLE WITH THE ENGINE IN PLACE

The parts listed below can be removed and reinstalled without removing the engine from the frame. Refer to the page listed in each section for removal and reinstallation instructions.

### ENGINE LEFT SIDE

	See page
Gearshift lever.....	3- 8
Engine sprocket cover.....	3- 8
Engine sprocket and drive chain.....	3- 8
Neutral indicator switch body.....	3-19
Starter clutch cover.....	3-18
Starter clutch.....	3-19
Starter idle gear.....	3-19

### ENGINE CENTER

	See page
Exhaust pipe/muffler.....	3- 7
Oil cooler.....	3- 7
Oil hose.....	3- 7
Oil filter.....	3-13
Oil pan.....	3-20
Sump filter.....	3-20
Carburetors.....	3- 6
Throttle cable.....	3- 6
Cam chain tensioner.....	3-13
Cylinder head cover.....	3-13
Camshafts.....	3-14
Starter motor.....	3-15
Generator.....	3-15

### ENGINE RIGHT SIDE

	See page
Signal generator cover.....	3-13
Signal generator.....	3-16
Oil pressure switch.....	3-58
Clutch cover.....	3-16
Clutch pressure, drive and driven plates.....	3-17
Oil pump driven gear.....	3-18
Generator/oil pump drive gears.....	3-14
Primary driven gear.....	3-17
Gearshift shaft.....	3-18
Gear shifting pawl and cam driven gear.....	3-18

## ENGINE REMOVAL AND REINSTALLATION

### ENGINE REMOVAL

Before taking the engine out of the frame, wash the engine with a steam cleaner. The procedure of engine removal is sequentially explained in the following steps, and engine installation is effected by reversing the removal procedure.

- Remove the lower fairing.
- Remove the left and right middle fairings.



- Remove both seats.



- Remove the pillion rider grabber.
- Remove the left and right frame covers.



- Remove two fuel tank mounting bolts.

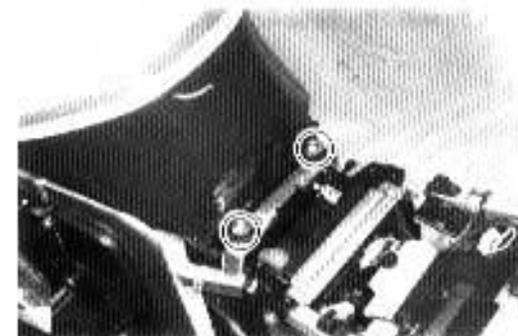

- Remove the fuel cock lever after positioning at "ON".

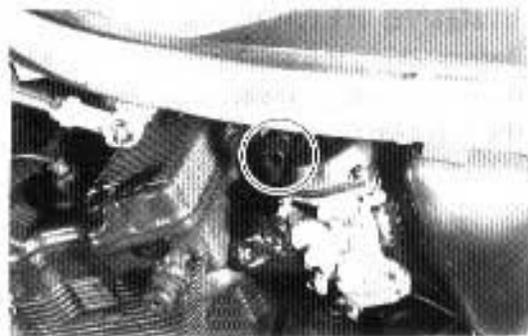

- Lift up the fuel tank and disconnect the fuel level indicator switch lead wires and all fuel hoses, then remove the fuel tank.



- Disconnect the breather hose from the cylinder head breather cover.



- Remove two air duct hoses.



- Loosen the respective carburetor clamp screws.



- Pulling out the clips from the air cleaner case and separate the carburetor assembly from all the outlet tubes and intake pipes.
- Remove the carburetor assembly from left side.
- Disconnect the throttle cable.



- Disconnecting the battery  $\ominus$  and  $\oplus$  lead wires from the battery terminals, remove the battery.

**CAUTION:**

Be sure to disconnect the  $\ominus$  lead wire first.

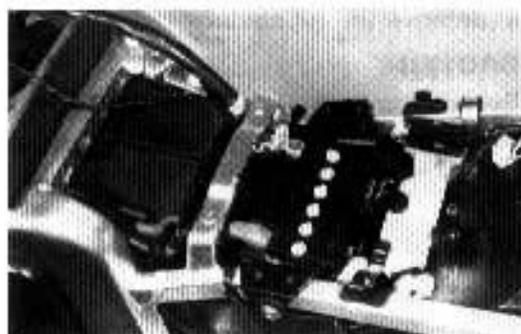

- Disconnect the following lead wires.
  - \* Battery  $\ominus$  lead wire (coupler ①)



- \* Generator lead wires (coupler ②)
- \* Neutral indicator switch lead wire (coupler ③)
- \* Signal generator lead wires (coupler ④)
- \* Oil pressure indicator switch lead wire (⑤)
- \* Side stand indicator lead wires (coupler ⑥)

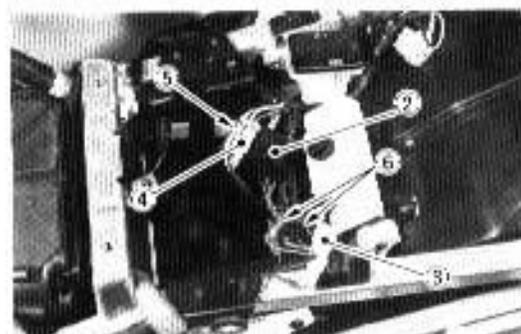

- \* Starter motor lead wire ⑦.



- Disconnect all the spark plug caps.

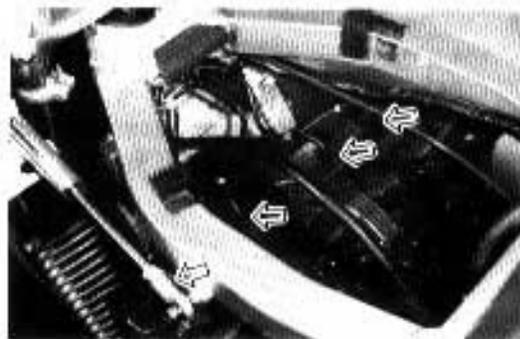

- Remove the oil cooler.

**CAUTION:**

Be sure to remove the oil hoses from the oil cooler, and remove the oil cooler mounting bolts.

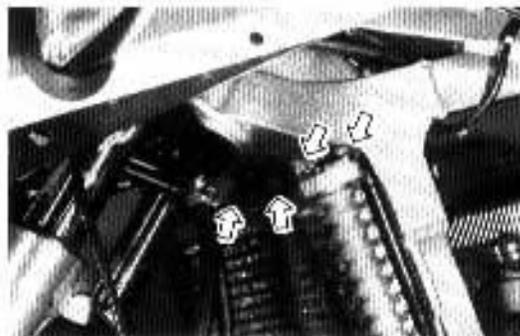

- Remove the eight exhaust pipe clamp bolts with a 6-mm hexagon wrench.



- After removing the muffler mounting bolts, take off the exhaust pipe/muffler.

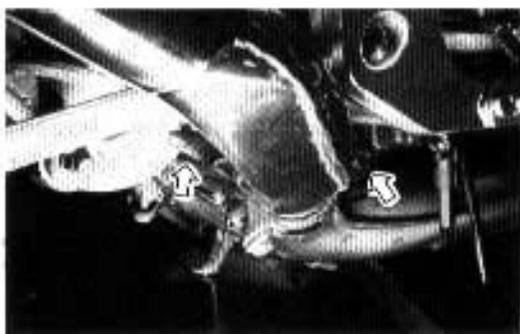



- Remove the oil drain plug to drain out engine oil.
- Remove two oil cooler hoses.



- After removing the gearshift lever securing bolt, take off the gearshift lever.
- Remove the engine sprocket cover.

**CAUTION:**

Do not operate the clutch lever to prevent clutch piston retainer damage.

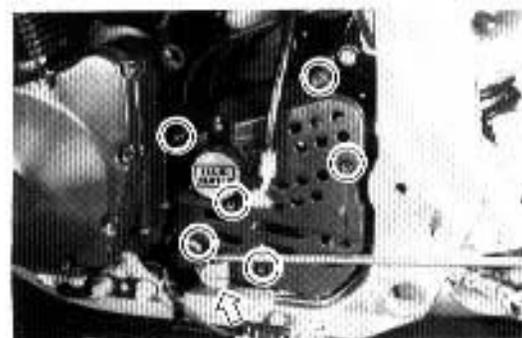

- Flatten the engine sprocket nut lock washer.
- Remove the engine sprocket nut while depressing the rear brake pedal.



- Loosen the axle nut and chain adjusters.
- Push the rear wheel forward to disengage the drive chain and remove the engine sprocket.

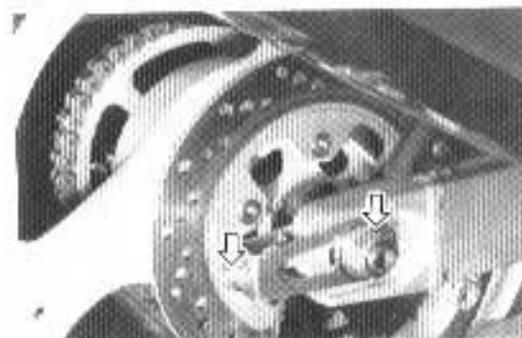

- Remove the engine mounting bolts, nuts, spacer and brackets.

**NOTE:**

*Support the engine with a proper engine jack.*

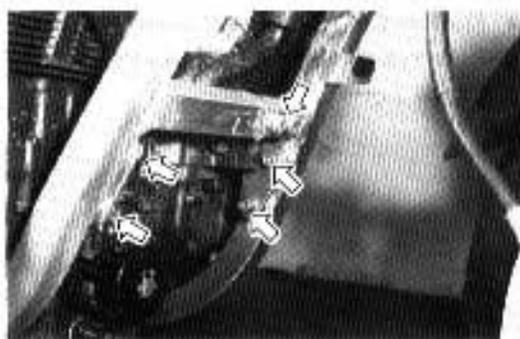
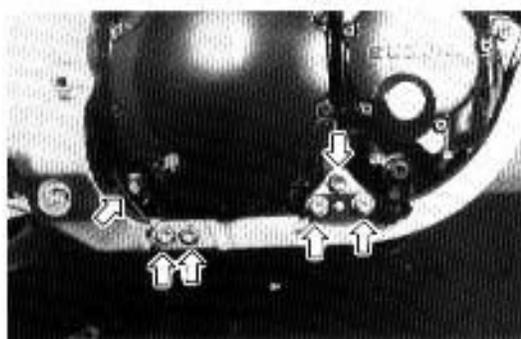
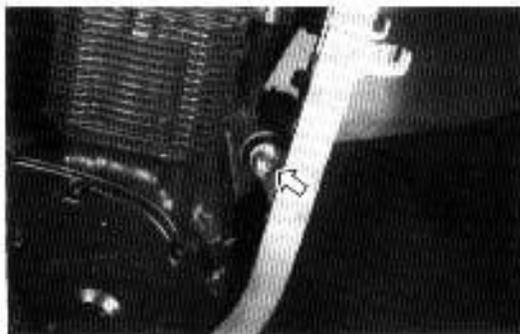
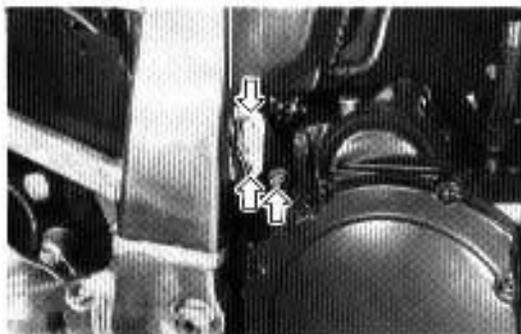

- Gradually lift up the engine, then lower the engine assembly on the right side making sure that it does not make contact with the frame.
- Remove the engine through the right side of the frame.

**NOTE:**

*If it is difficult to remove the engine, remove the air cleaner case mounting screws to provide additional clearance.*

## ENGINE REINSTALLATION

Reinstall the engine in the reverse order of engine removal.

- Insert the two long bolts from the left side. Install the brackets, spacers, bushes, bolts and nuts properly, as shown in the illustration on next page.

### NOTE:

*The engine mounting nuts are self-locking. Once the nut has been removed, it is no longer of any use. Be sure to use new nuts and tighten them to the specified torque.*

### TIGHTENING TORQUE

ITEM	N-m	kg-m	lb-ft
①, ②	70 - 88	7.0 - 8.8	50.5 - 63.5
③, ④	50 - 60	5.0 - 6.0	36.0 - 43.5
Other bolts	25 - 38	2.5 - 3.8	18.0 - 27.5

### LENGTH

Bolt ①	178 mm (7.0 in)
Bolt ②	150 mm (5.9 in)
Bolt ③	55 mm (2.2 in)
Bolt ④	55 mm (2.2 in)
Spacer RH ⑤	27 mm (1.1 in)
Bush (R & L) ⑥	39 mm (1.5 in)

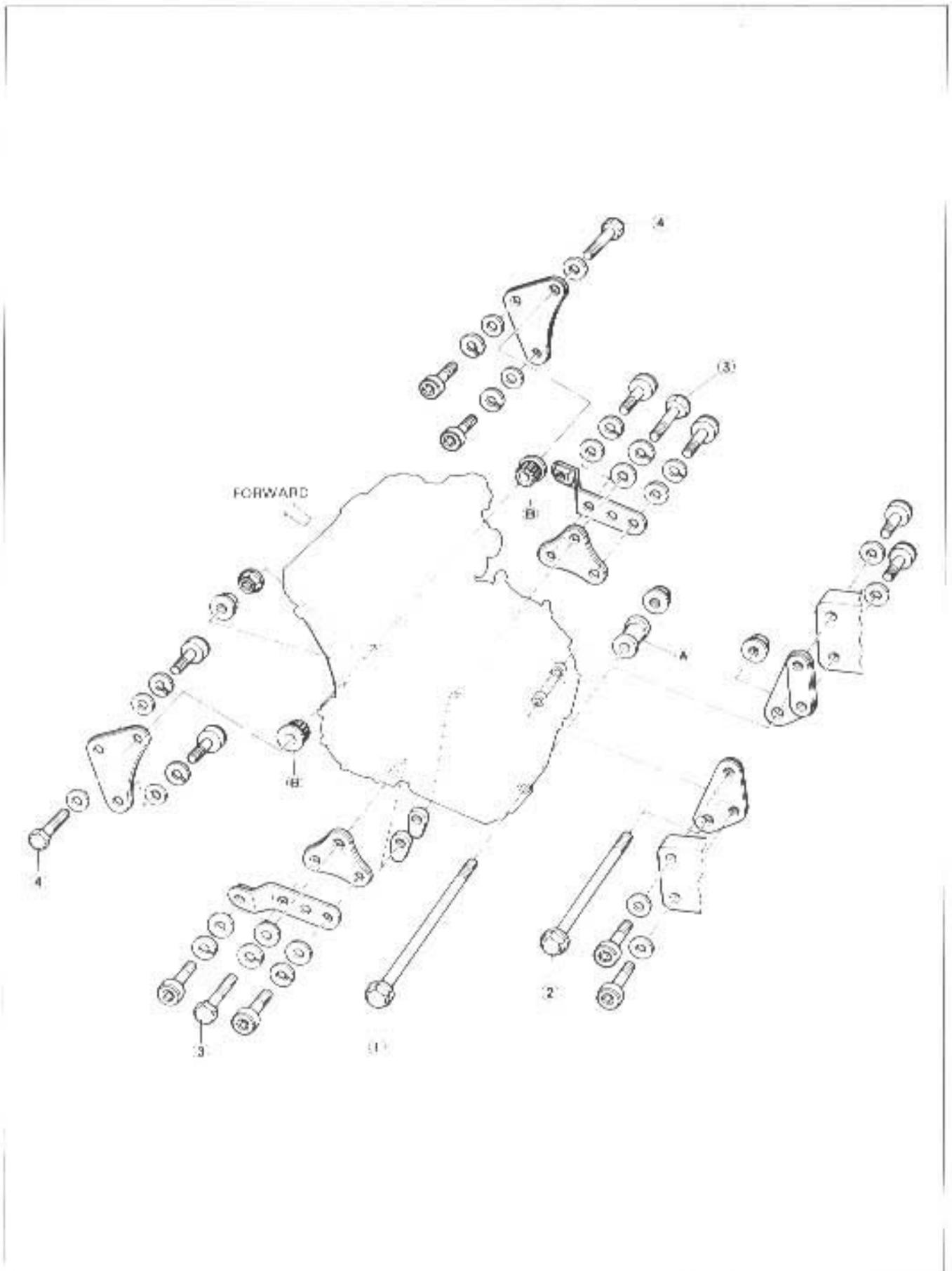

- Replace the plug caps on the spark plugs so that their code markings correspond to the cylinder numbers arranged in the order of 1, 2, 3 and 4 from the left hand.

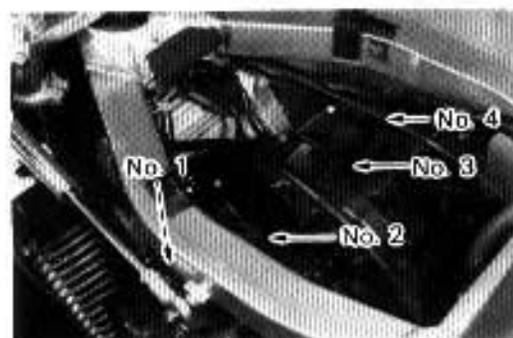

- Locate the carburetor clamps, as shown in the illustration.

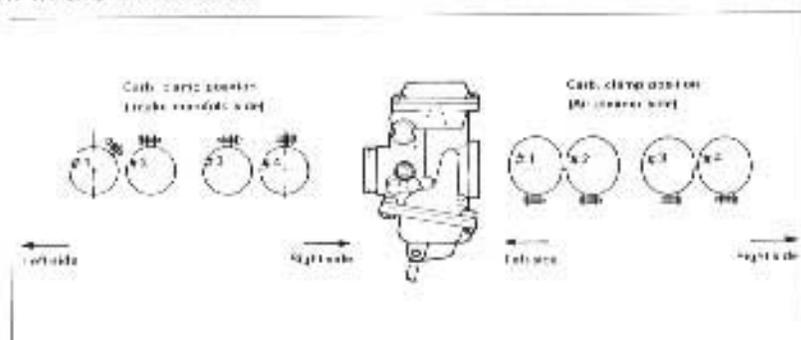

- Pour 5.1L of engine oil SAE 10W/40 under API classification SF into the engine.

Several minutes after starting and stopping the engine, check that the oil level remains between the marks of the oil inspection window.

**OIL CHANGE:** 4000 ml (4.2/3.5 US/Imp qt)

**OIL AND FILTER CHANGE:** 4200 ml (4.4/3.7 US/Imp qt)

**OVERHAUL:** 5100 ml (5.4/4.5 US/Imp qt)

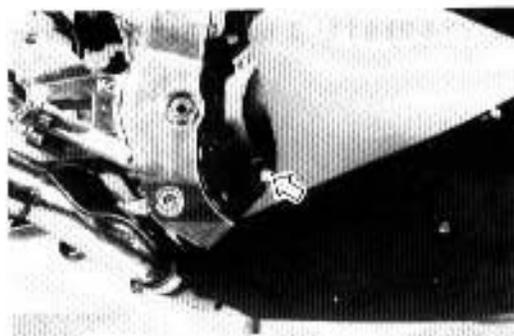

- Tighten the engine sprocket cover bolts sequentially in the ascending order of numbers.
- After remounting the engine, route wiring harnesses, cables and hoses properly by referring to the sections, for wire routing, cable routing and hose routing. (see pages 7-14 through 24)
- Adjust the following items to the specification:

	Page
* Throttle cable .....	2- 9
* Drive chain .....	2-11
* Idling adjustment.....	2- 9
* Balancing carburetors.....	4-15

## ENGINE DISASSEMBLY

- Remove the oil filter by using the special tool.

**09915-40610: Oil filter wrench**

*NOTE:*

*Refer to page 2-8 for installation procedures.*

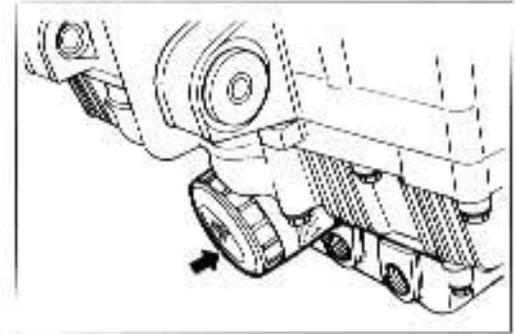

- Remove the cylinder head cooling oil hoses by removing the bolts.

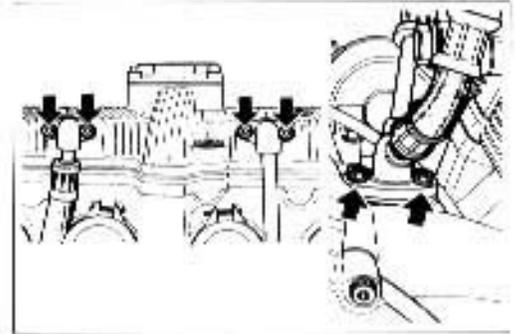

- Remove the cylinder head cover by removing the bolts.

**09914-25811: 6 mm "T" type hexagon wrench**

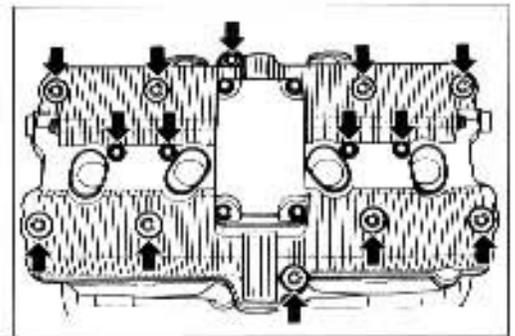

- Remove the signal generator cover by removing the bolts.

**09911-73730: 5 mm "T" type hexagon wrench**

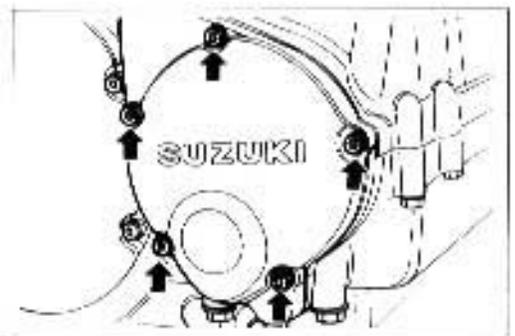

- Remove the spring holder bolt and spring, and then remove the cam chain tensioner by removing the bolts.

**09911-73730: 5 mm "T" type hexagon wrench**

- Remove the cam chain idler by removing the bolts.

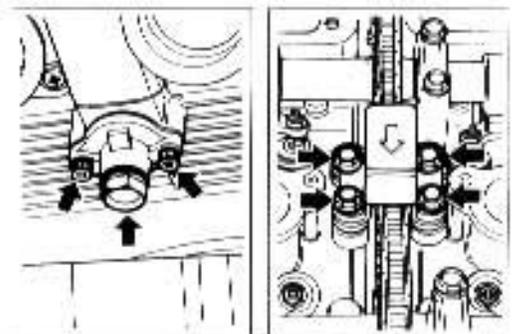

- Remove the ten camshaft journal holders by removing the bolts.

**NOTE:**

*Be sure to loosen camshaft journal holder bolts evenly by shifting the wrench diagonally.*

- Remove the two camshafts, intake and exhaust.

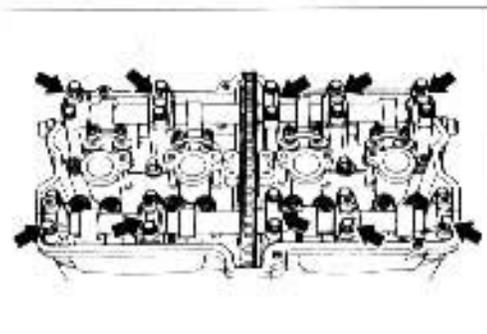

- Pull out the cam chain guide.

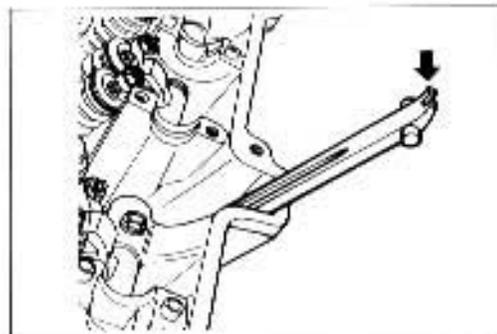

- The cylinder head becomes free for removal when its one 6-mm bolt (A) and twelve 10-mm nuts are removed.

**09911-74510: Long socket 14 mm**

**09914-24510: T handle**

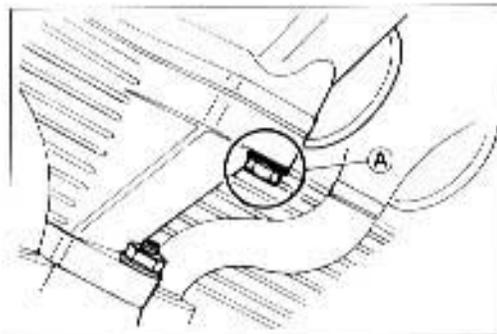
**NOTE:**

*When loosening the cylinder head nuts, loosen each nut little by little, in a descending order, according to the numbers cast on a cylinder head.*

**CAUTION:**

**Be careful not to damage the fins when removing or handling the cylinder head. This precaution applies to the cylinder block also.**

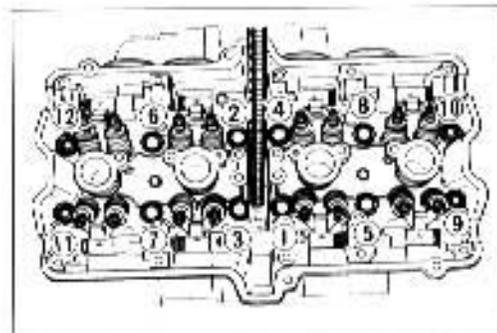

- Remove the right and left oil pipes (I).
- Remove the cylinder nut (B).

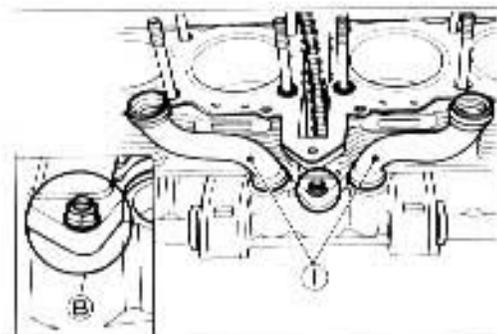

- Firmly grip the cylinder block at both ends, and lift it straight up. If the block does not come off, lightly tap on the finless portions of the block with a plastic mallet to make the gasketed joint loose.

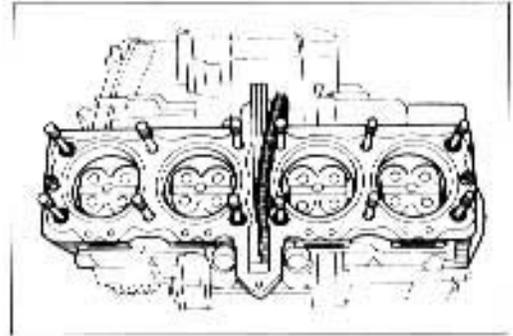

- Scribe the cylinder number on the head of the respective pistons.

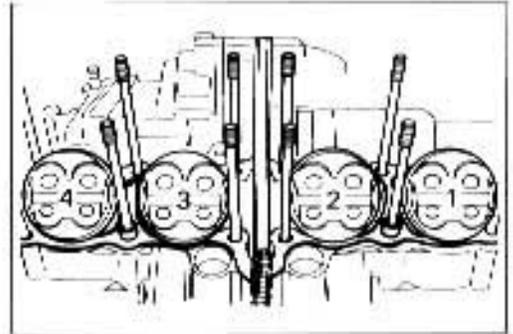

- Place a cloth beneath the piston so as not to drop any parts in the crankcase, and remove the circlip (1) with long-nose pliers.
- Draw out the piston pin. Place each piston pin in the same piston as that it was removed from.



- Remove the starter motor by removing the bolts.

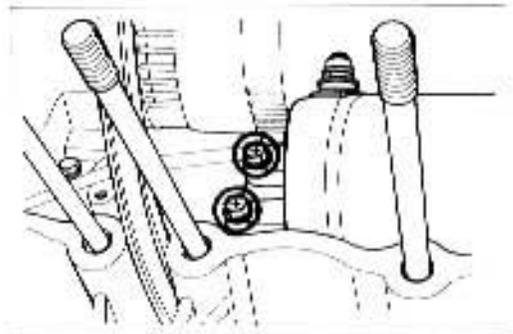

- Remove the generator by removing the bolts.

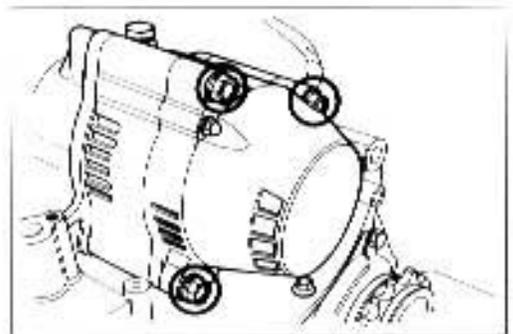



- Remove the signal generator rotor by removing the bolt.

**09900-00410: Hexagon wrench set**  
(Not available in U.S.A.)

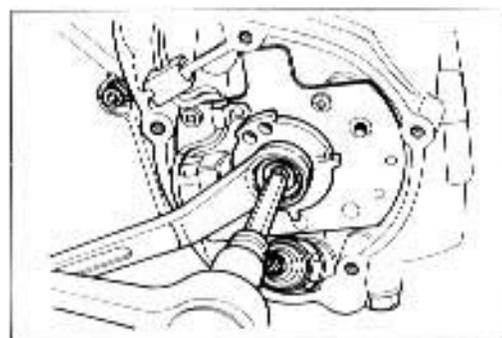

- Disconnect the oil pressure switch lead wire.
- Remove the signal generator stator by removing the three screws.

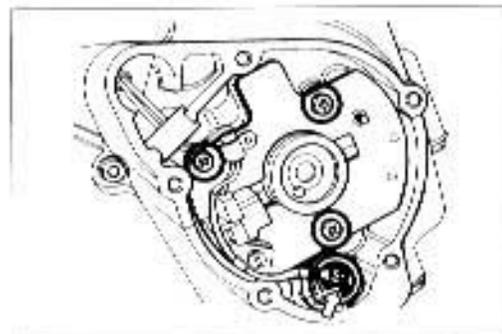

- Remove the clutch cover by removing the bolts.

**09911-73730: 5 mm "T" type hexagon wrench**

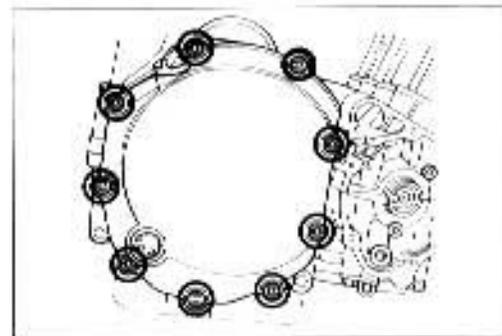

- Remove the pressure plate lifter (1) by removing the circlip.

**09900-06108: Snap ring pliers**

- After removal of pressure plate lifter (1), remove the thrust washer (2), bearing (3) and clutch push piece (4), and draw out the clutch push rods, (5) and (6).

**NOTE:**

*If it is difficult to draw out the push rod (5), use a magnetic hand or wire.*

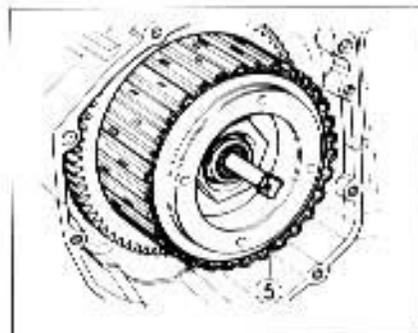
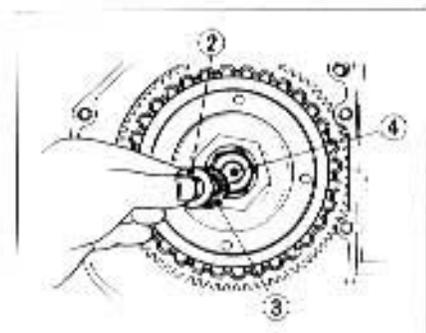
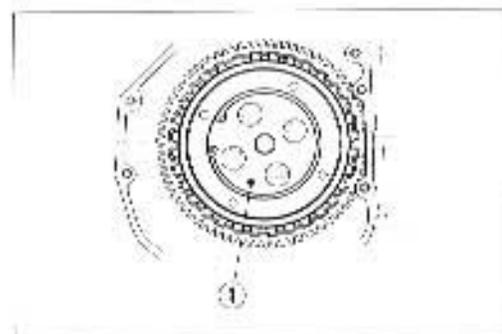

- Remove the clutch diaphragm spring holder nut with the special tools.

**09920-34820: Clutch pressure plate holder**

**09941-58010: 50 mm socket wrench**

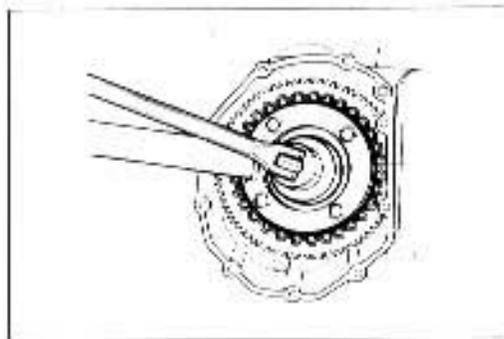

- After removing the clutch diaphragm spring holder nut, remove the clutch diaphragm springs (1), clutch diaphragm spring seat (2) and clutch pressure plate (3).

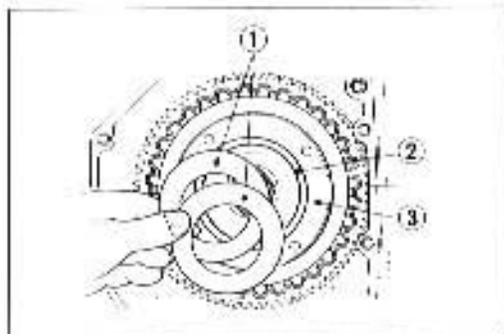

- After removing the several clutch plates, remove the clutch sleeve hub nut after firmly locking the clutch sleeve hub with a clutch sleeve hub holder, and then remove the remainder of clutch drive and driven plates along with the clutch sleeve hub.

**09920-50710: Clutch sleeve hub holder**

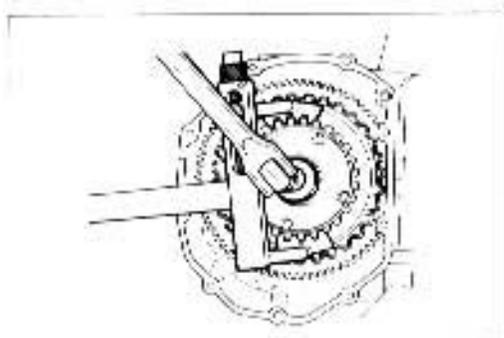

- Remove the thrust washer (1).

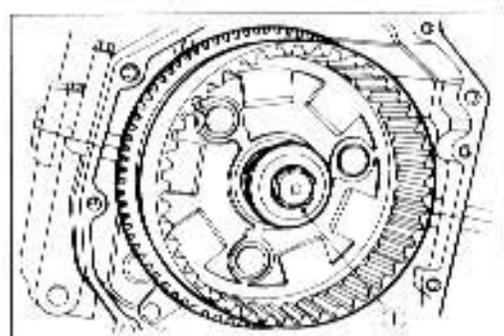

- With the spacer removed, the primary driven gear (integral with the clutch housing) is free to disengage from the primary drive gear.
- Remove the primary driven gear assembly with the generator/oil pump drive gears.

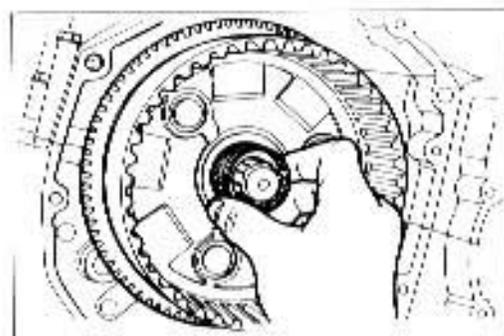

- Remove the thrust washer (2).

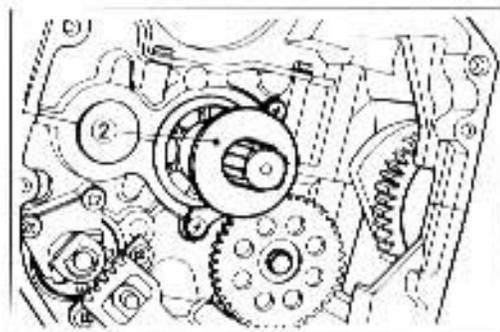

- Remove the clip and washer from the gearshift shaft.

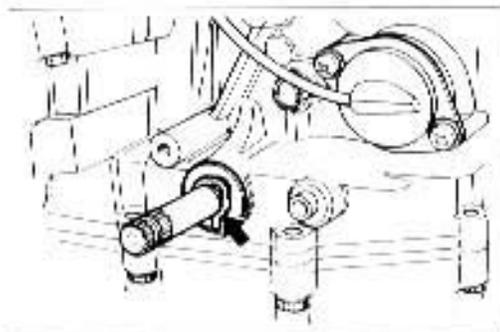

- Draw out the gearshift shaft (1), and then remove the cam driven gear (2) by removing the screws (3).

**09900-09003: Impact driver set**

**NOTE:**

When removing the cam driven gear, do not lose the gear shifting pawl (4), pin (5) and spring (6).

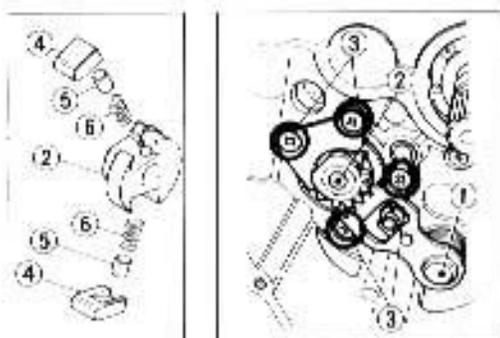

- Remove the oil pump driven gear by removing the circlip.

**09900-06107: Snap ring pliers**

**NOTE:**

Do not lose the circlip, pin and washers.

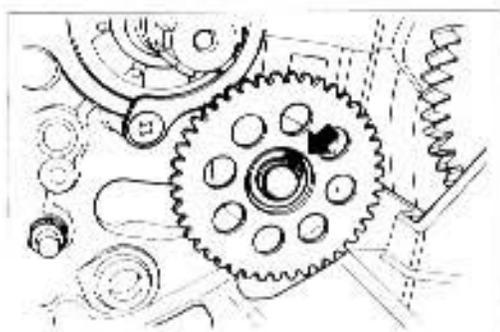

- Remove the starter clutch cover by removing the bolts.

**09911-73730: 5 mm "T" type hexagon wrench**

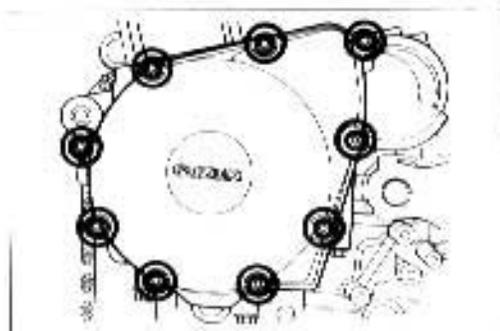

- Remove the starter idle gear and its shaft.

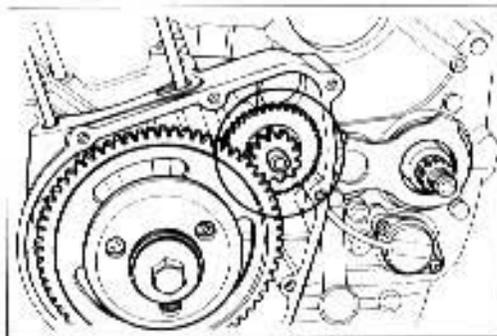

- Loosen the starter clutch mounting bolt by using the special tool.

**09920-34810: Starter clutch holder**

**NOTE:**

*When removing the starter clutch assembly from the crankshaft, do not remove the starter clutch mounting bolt only loosen the bolt. The starter clutch mounting bolt is used in conjunction with the special tool.*

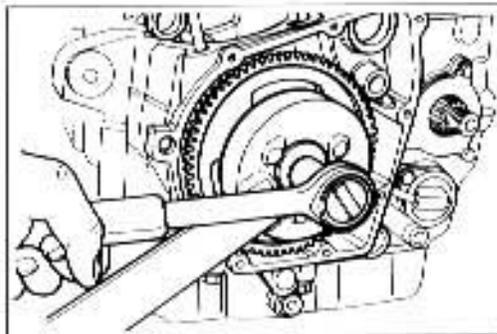

- Remove the starter clutch assembly from the crankshaft by using the special tool.

**09930-33720: Rotor remover**

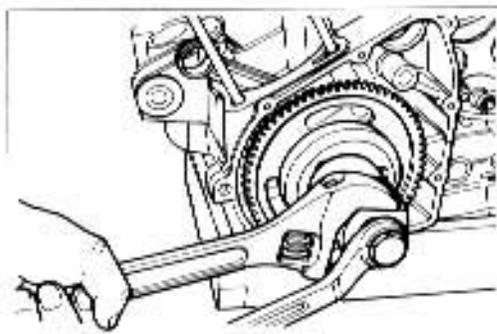

- Flatten the lock portion of the oil seal retainer and remove it by removing the four bolts.
- Remove the neutral position indicator switch by removing the screws.

**NOTE:**

*Do not lose the O-ring ①, switch contact ② and its spring ③.*

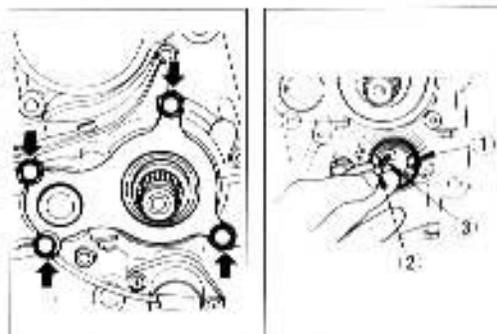

- Remove the countershaft bearing retainer by removing the two screws.

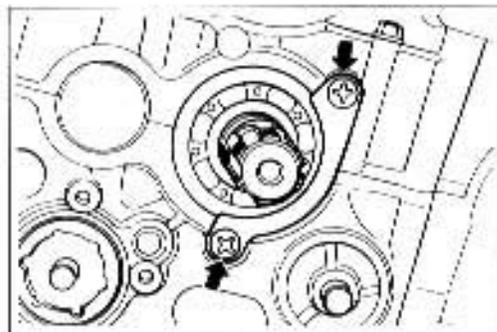

- Remove the plug ① on the upper crankcase.
- Remove the upper crankcase securing bolts and nut.

**09911-73730: 5 mm "T" type hexagon wrench**

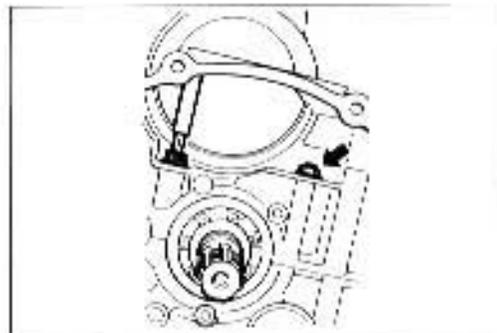
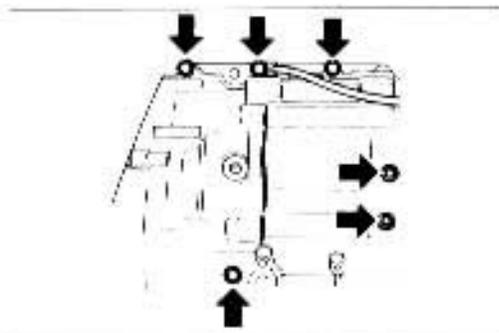
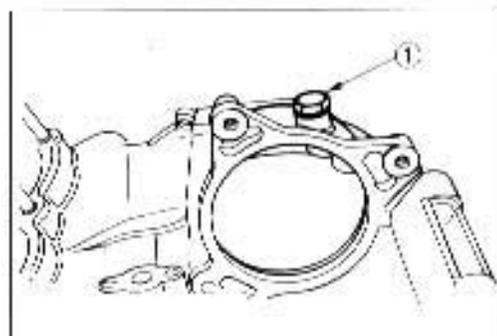

- Remove the oil pan by removing the bolts.
- 09911-73730: 5 mm "T" type hexagon wrench**

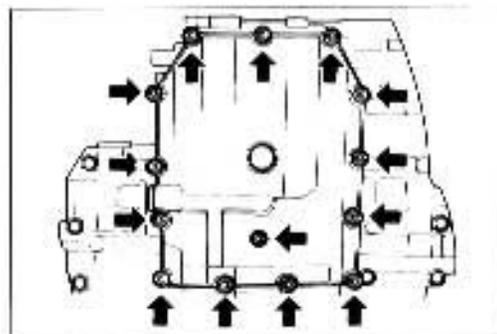

- Remove the shim ① and O-ring ②.
- Remove the oil sump filter ③ by removing the four bolts.
- Remove the left oil pipe ④ by removing the bolt.

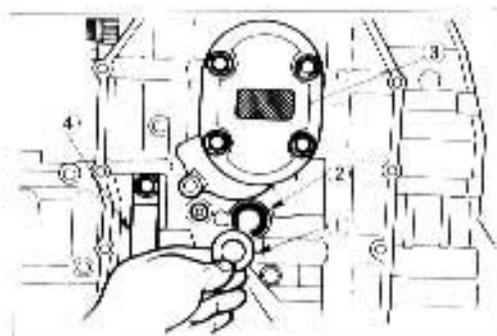

- Remove the oil sump filter guide ⑤ by removing the two bolts.

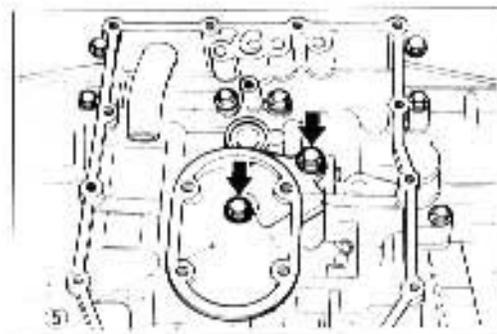

- Remove the lower crankcase securing bolts and nut.

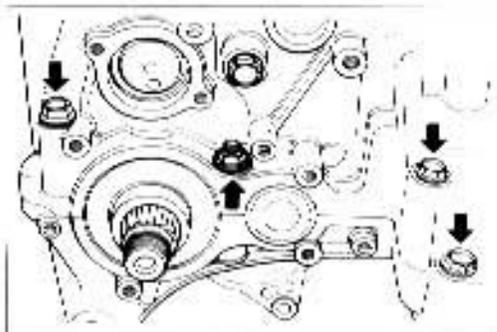
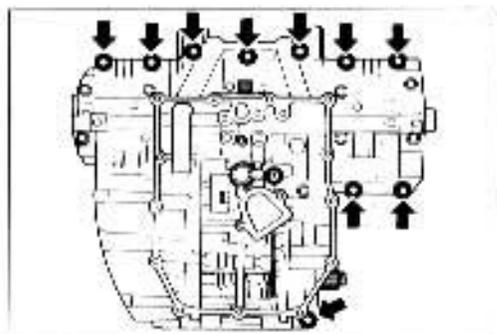

- When removing the crankshaft tightening bolts, loosen them in the descending order of numbers assigned to these bolts.

**NOTE:**

- \* Two allen bolts are used for tightening the crankshaft at (A).
- \* Before removing the crankshaft tightening bolts, remove the main oil gallery plug (B).
- \* When installing the main oil gallery plug (B), replace the O-ring with new one and tighten it to the specified torque.

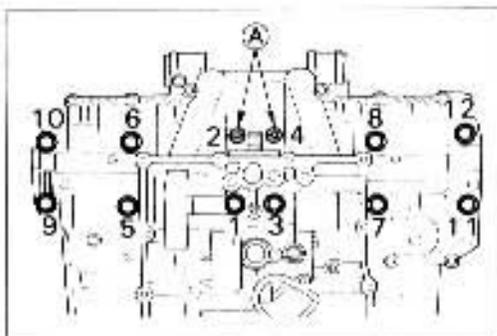

09914-25811: 6 mm "T" type hexagon wrench

09900-00410: Hexagon wrench set  
{Not available in U.S.A.}

**Tightening torque**

Main oil gallery plug (B): 35 – 45 N·m  
{3.5 – 4.5 kg·m, 25.5 – 32.5 lb-ft}

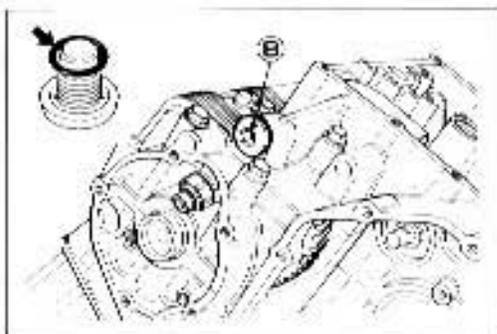

- Make sure that all bolts are removed. Hammer lightly the lower crankcase side with a plastic hammer to separate the upper and lower crankcase halves and then lift the latter.

**CAUTION:**

Do not drop the crankshaft journal bearings from the lower crankcase.

- Remove the crankshaft assembly from the upper crankcase.

**NOTE:**

*Bear in mind that the crankshaft thrust bearings (C) are located between the shaft and case.*

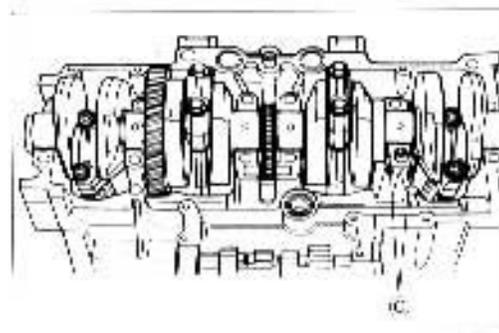

- Pull out the two dampers (1) and cam chain guide (2).
- Remove the O-rings, (3) and (4).

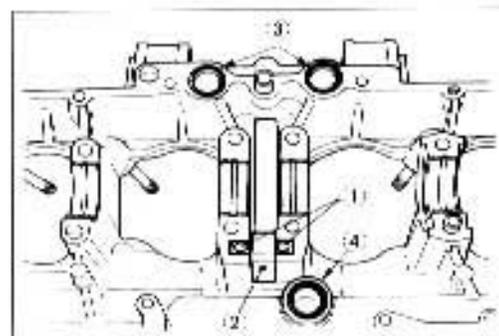

- Remove the countershaft assembly (5) and driveshaft assembly (6).

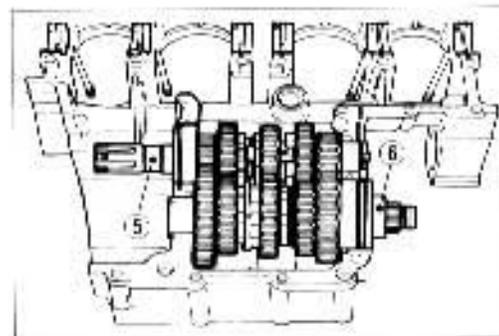

**NOTE:**

*Do not lose the C-rings (7) and bearing pins (8).*

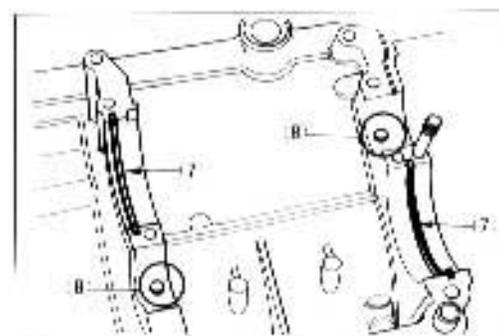

- Hold the gearshift forks by hand while drawing out the gearshift fork shaft from the lower crankcase

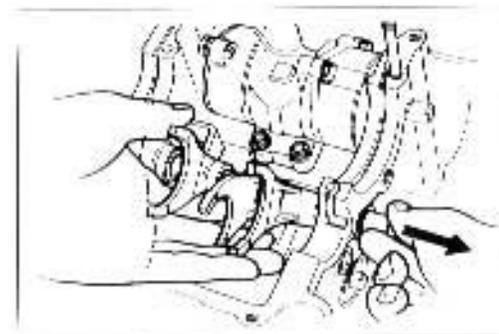

- Unhook the gearshift cam stopper spring from the lower crankcase.

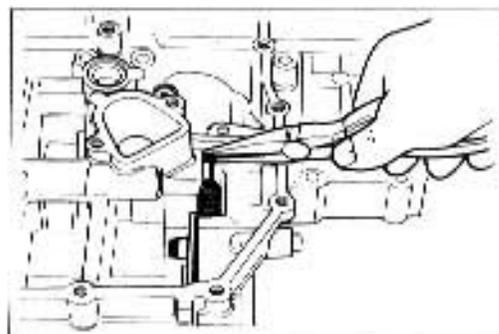

- Remove the circlip (1) from the gearshift cam, and then draw out the gearshift cam from the other side.

**09900-06107: Snap ring pliers**

*NOTE:*

When replacing the gearshift cam stopper bolt (2), apply a small quantity of **THREAD LOCK "1342"** to the bolt.

**99000-32050: THREAD LOCK "1342"**

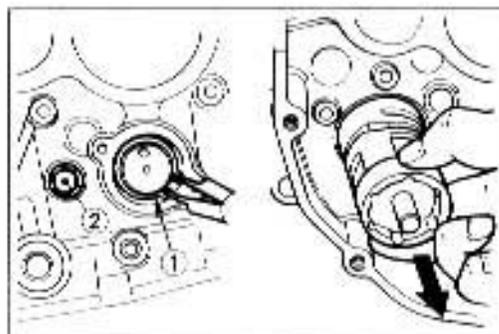

- Remove the gearshift cam stopper (3) by removing the circlip (4).

**09900-06107: Snap ring pliers**

*NOTE:*

Rotate the bearing (5) by hand to inspect for abnormal noise and smooth rotation. Replace the bearing if there is anything unusual.

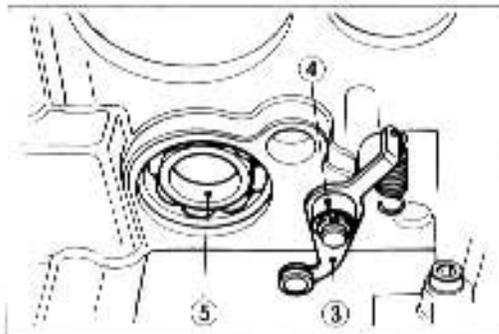

- Remove the oil pump by removing the mounting bolts.

**09900-00410: Hexagon wrench set**  
(Not available in U.S.A.)

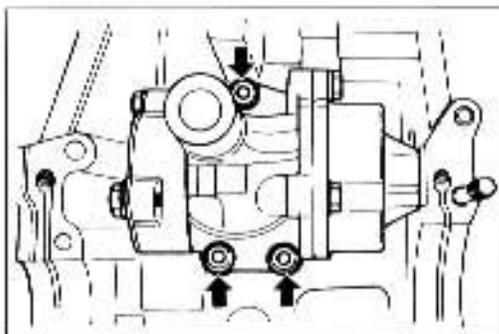

- Remove the O-rings and dowel pins.

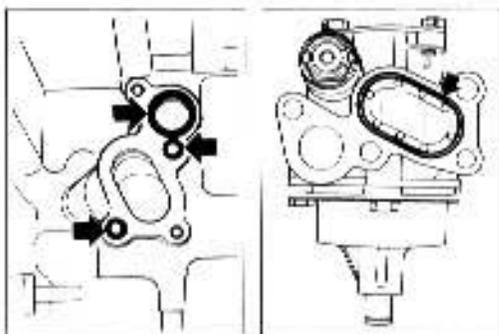



## ENGINE COMPONENTS INSPECTION AND SERVICING

### CYLINDER HEAD SERVICING

#### CAUTION:

Be sure to identify each removed part as to its location, and lay the parts out in groups designated as "No. 1", "No. 2", "Exhaust", "Inlet", so that each will be restored to the original location during assembly.

#### NOTE:

- \* When removing the rocker arm shaft, remove the rocker arm shaft set bolt ① and plug ②, screw an 8 mm bolt into the rocker arm shaft end and pull it out.
- \* Tighten the set bolt ① and plug ② to the specified torque.
- \* Removal of valves completes ordinary disassembling work. If valve guides have to be removed for replacement after inspecting related parts, carry out the steps shown in valve guide servicing.

#### Tightening torque

Set bolt ① : 8 - 12 N·m (0.8 - 1.2 kg-m, 6.0 - 8.5 lb-ft)

Plug ② : 25 - 30 N·m (2.5 - 3.0 kg-m, 18.0 - 21.5 lb-ft)

- Using special tools, compress the valve springs and take off the two cotter halves ① from valve stem.

09916-14510: Valve lifter

09916-14910: Valve lifter attachment

09916-84510: Tweezers

- Take out the spring retainer, inner and outer springs.
- Pull out the valve from the other side.

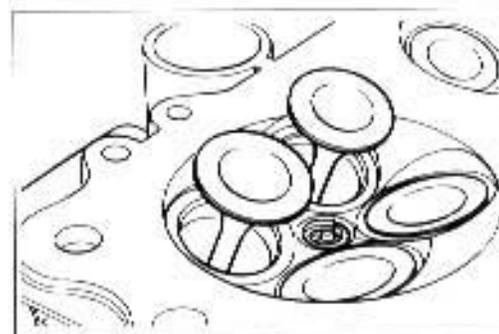
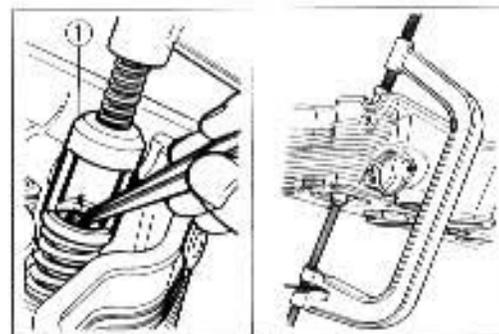
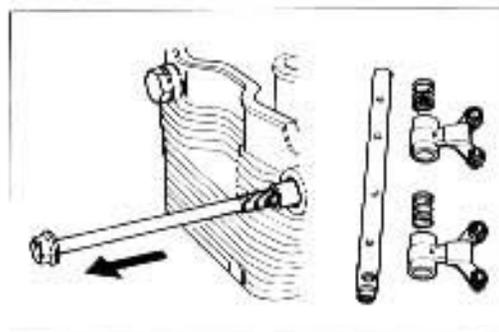

## CYLINDER HEAD DISTORTION

Decarbonize the combustion chambers.

Check the gasketed surface of the cylinder head for distortion with a straightedge and thickness gauge, taking a clearance reading at several places indicated. If the largest reading at any position of the straightedge exceeds the limit, replace the cylinder head.

**09900-20803: Thickness gauge**  
**Service Limit : 0.2 mm (0.008 in)**

## VALVE STEM RUNOUT

Support the valve with "V" blocks, as shown, and check its runout with a dial gauge.

The valve must be replaced if the runout exceeds the limit.

**Service Limit: 0.05 mm (0.002 in)**

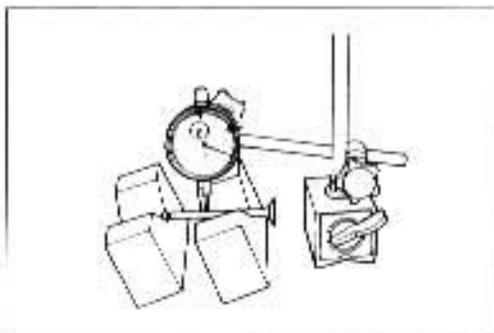
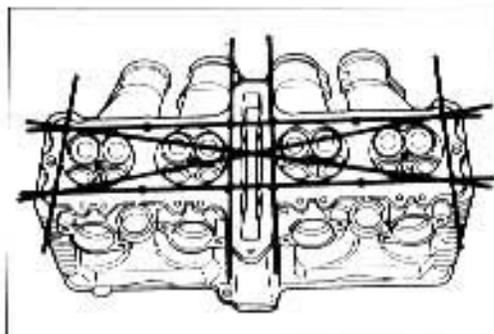

## VALVE HEAD RADIAL RUNOUT

Place the dial gauge at right angles to the valve head face, and measure the valve head radial runout.

If it measures more than the limit, replace the valve.

**Service Limit: 0.03 mm (0.001 in)**

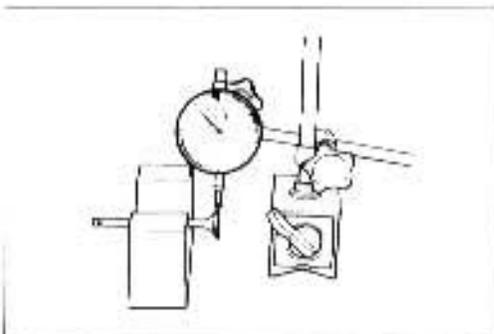

## VALVE FACE WEAR

Visually inspect each valve for wear of its seating face. Replace any valve with an abnormally worn face.

The thickness (1) decreases as the wear of the face advances. Measure the thickness and, if the thickness is found to have been reduced to the limit, replace it.

**Service Limit (1): 0.5 mm (0.02 in)**

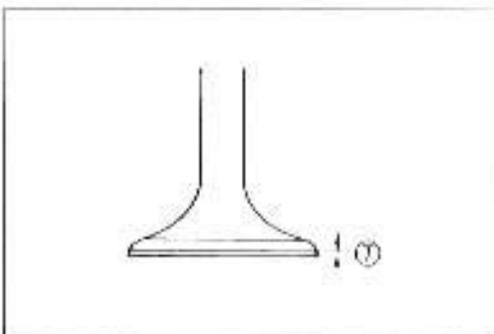

## VALVE GUIDE - VALVE STEM CLEARANCE

Measure the clearance in two directions, "X" and "Y", perpendicular to each other, by positioning the dial gauge as shown. If the clearance measured exceeds the limit, (see below) then determine whether the valve or the guide should be replaced to reduce the clearance to the standard range:

**Service Limit**

**Intake valves : 0.35 mm (0.014 in)**

**Exhaust valves: 0.35 mm (0.014 in)**

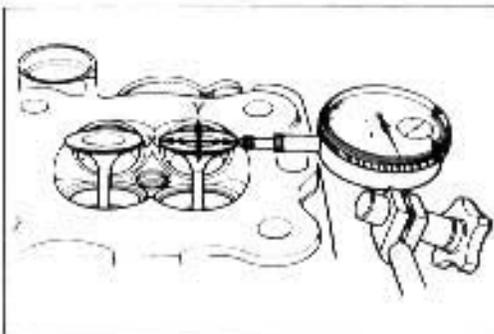

## VALVE STEM WEAR

If the valve stem is worn down to the limit, as measured with a micrometer, where the clearance is found to be in excess of the limit indicated, replace the valve; if the stem is within the limit, then replace the guide. After replacing valve or guide, be sure to recheck the clearance.

**09900-20205: Micrometer (0 – 25 mm)**

**Standard**

**Intake valves : 4.965 – 4.980 mm (0.1955 – 0.1961 in)**

**Exhaust valves: 4.945 – 4.960 mm (0.1947 – 0.1953 in)**



## VALVE GUIDE SERVICING

- Using the valve guide remover (1), drive the valve guide out toward the intake or exhaust camshaft side.

**09916-44310: Valve guide remover/installer**

**NOTE:**

- \* Discard the removed valve guide subassemblies.
- \* Only oversized valve guides are available as replacement parts. (Part No. 11116-06B70)

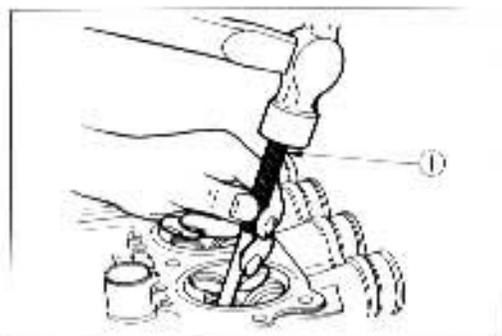

- Re-finish the valve guide holes in cylinder head with the reamer and handle.

**09916-34580: Valve guide reamer**

**09916-34541: Reamer handle**

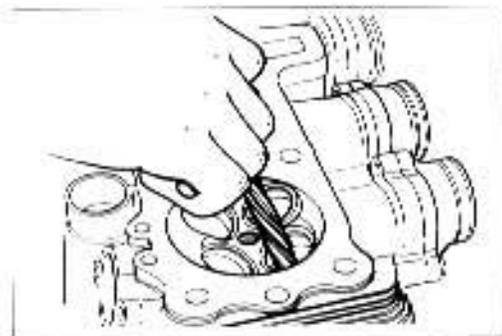

- Fit a ring to each valve guide. Be sure to use new rings and valve guides. Rings and valve guides removed in disassembly must be discarded.
- Oil the stem hole, too, of each valve guide and drive the guide into the guide hole with the valve guide installer.

**09916-44310: Valve guide remover/installer**

**CAUTION:**

**Failure to oil the valve guide hole before driving the new guide into place may result in a damaged guide or head.**

- After fitting the valve guides, re-finish their guiding bores with the reamer. Be sure to clean and oil the guides after reaming.

**09916-34570: Valve guide reamer**

**09916-34541: Reamer handle**

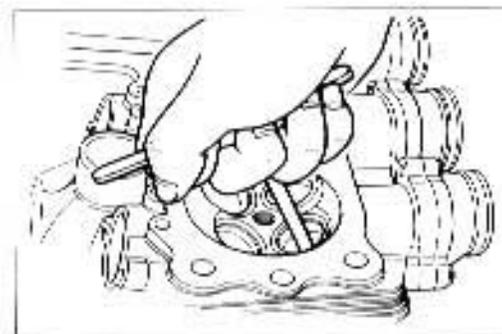
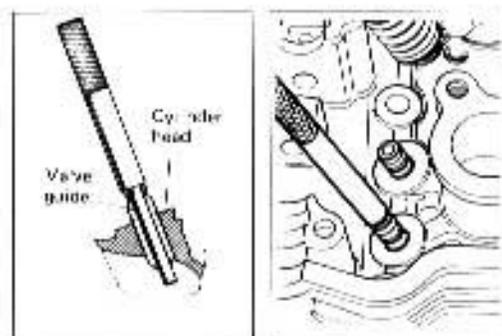

## VALVE SEAT WIDTH

- Coat the valve seat uniformly with Prussian blue. Fit the valve and tap the coated seat with the valve face in a rotating manner, in order to obtain a clear impression of the seating contact. In this operation, use the valve lapper to hold the valve head.
- The ring-like dye impression left on the valve face must be continuous-without any break. In addition, the width of the dye ring, which is the visualized seat "width", must be within the following specification:

### Standard

Valve seat width  $\text{W}$ : 0.9 – 1.1 mm (0.035 – 0.043 in)

If either requirement is not met, correct the seat by servicing it as follows:

## VALVE SEAT SERVICING

The valve seats for both intake and exhaust valves are machined to two different angles. The seat contact surface is cut 45° and the area above the contact surface (closest to the combustion chamber) is cut to 15°.

	Intake side	Exhaust side
45°	N-116 or 122	N-116 or 122
15°	N-116 or 121	N-120 or 121

(For U.S.A. model)

Valve seat cutter : (N-121), (N-122), (N-116) and (N-120)

Solid pilot : (N-100-5.0)

(For the other models)

09916-20610: Valve Seat Cutter (N-121)

09916-20620: Valve Seat Cutter (N-122)

09916-24420: Valve Seat Cutter (N-116)

09916-29010: Valve Seat Cutter (N-120)

09916-24311: Solid Pilot (N-100-5.0)

09916-21110: Valve Seat Cutter set

### NOTE:

The valve seat contact area must be inspected after each cut.

- Insert the solid pilot (1) with a slight rotation. Seat the pilot snugly. Install the 45° cutter, attachment and T handle.
- Using the 45° cutter, descale and clean up the seat with one or two turns.
- Inspect the seat by the previously described seat width measurement procedure. If the seat is pitted or burned, additional seat conditioning with the 45° cutter is required.

### NOTE:

Cut only the minimum amount necessary from the seat to prevent the possibility of the valve stem becoming too close to the rocker arm for correct valve contact angle.

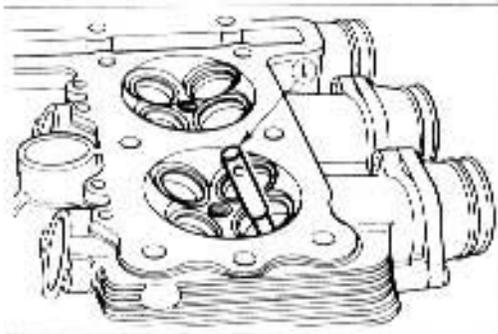
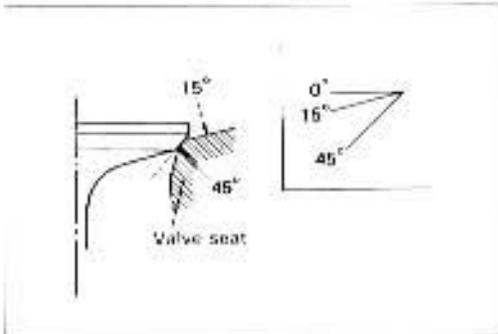
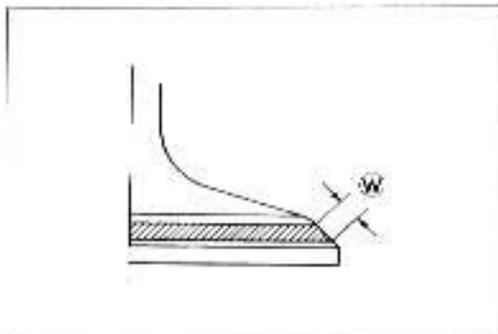
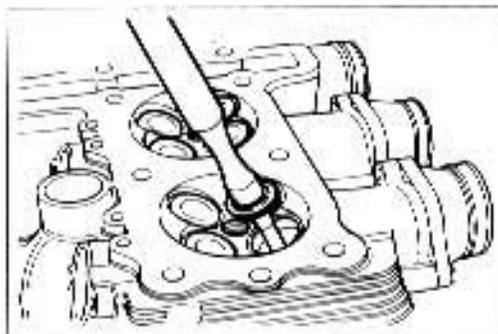

If the contact area is too high on the valve, or if it is too wide, use the 15° cutter to lower and narrow the contact area.

Contact area too high and too wide on face of valve.

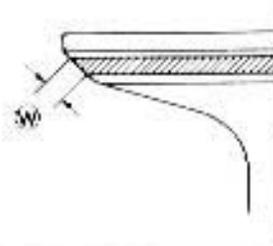

If the contact area is too low or too narrow, use the 45° cutter to raise and widen the contact area.

Contact area too low and too narrow on face of valve.

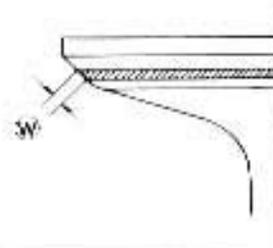

- After the desired seat position and width is achieved, use the 45° cutter very lightly to clean up any burrs caused by the previous cutting operations.

**CAUTION:**

**DO NOT** use lapping compound after the final cut is made. The finished valve seat should have a velvety smooth finish, not a highly polished or shiny finish. This will provide a soft surface for the final seating of the valve which will occur during the first few seconds of engine operation.



- Clean and assemble the head and valve components. Fill the intake and exhaust ports with gasoline to check for leaks. If any leaks occur, inspect the valve seat and face for burrs or other things that could prevent the valve from sealing.

**WARNING:**

**Always use extreme caution when handling gasoline.**

**NOTE:**

*After servicing the valve seats, be sure to adjust the valve clearance after the cylinder head has been reinstalled. (see page 2-5)*

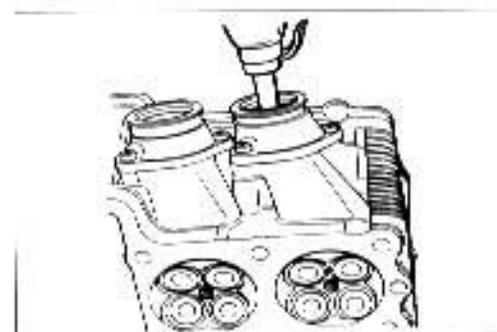

## VALVE STEM END CONDITION

### CAUTION:

- \* Refacing the valve stem end face is permissible where the length ① will not be reduced to less than 2.5 mm. If this length becomes shorter than 2.5 mm, then the valve must be replaced.
- \* After installing the valve whose stem end has been ground off as above, check that the face ② of valve stem end is above the valve cotter ③.

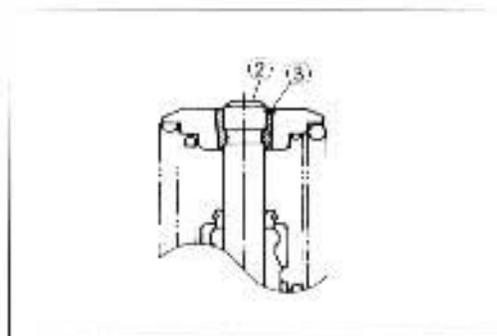
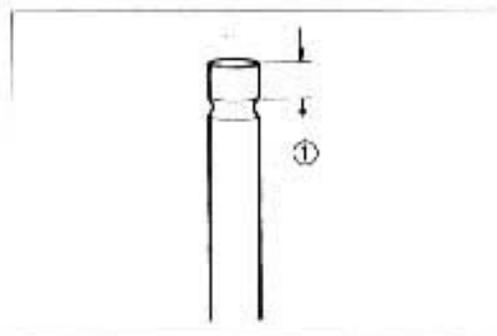

## VALVE SPRINGS

The force of the two coil springs keeps the valve seat tight. Weakened springs result in reduced engine power output, and often account for the chattering noise coming from the valve mechanism.

Check the valve springs for proper strength by measuring their free lengths and also by the force required to compress them. If the spring length is less than the service limit, or if the force required to compress the spring does not fall within the range specified, replace both the inner and outer springs as a set.

### CAUTION:

Replace both the valve springs, inner and outer, at a time, if any one of these is found to be beyond the limit.

#### Valve spring free length

Service Limit    INNER : 35.0 mm (1.38 in)  
                           OUTER: 37.8 mm (1.49 in)

#### Valve spring tension

Standard            INNER : 5.3 – 6.5 kg/28 mm  
                           (11.7 – 14.3 lbs/1.10 in)  
                           OUTER: 13.1 – 15.1 kg/31.5 mm  
                           (28.9 – 33.3 lbs/1.24 in)

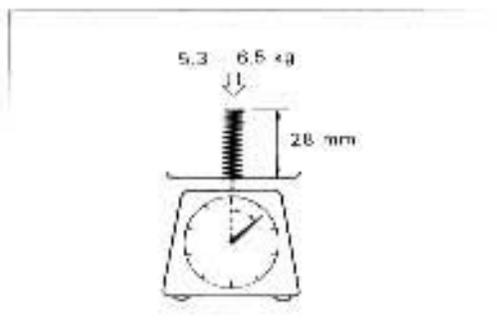
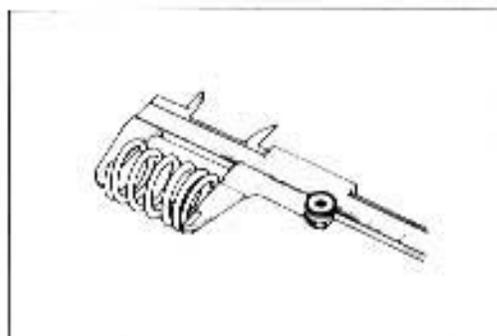

## REASSEMBLY

- Oil each oil seal, and press-fit them into position with the finger tip.

### CAUTION:

Do not reuse the oil seals.

### NOTE:

Be sure to restore the plate (A) on the cylinder head of exhaust side.

- Install the valve spring lowr seats, (1) (for exhaust ) and (2) (for intake). Be careful not to confuse the lower seat with the spring retainer (3).

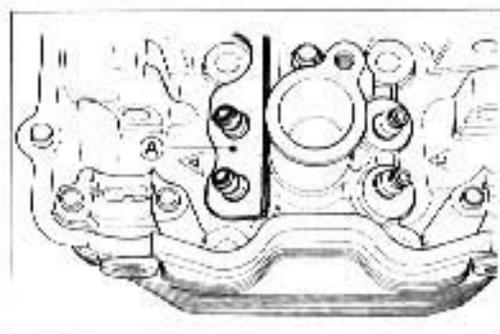

For Intake side

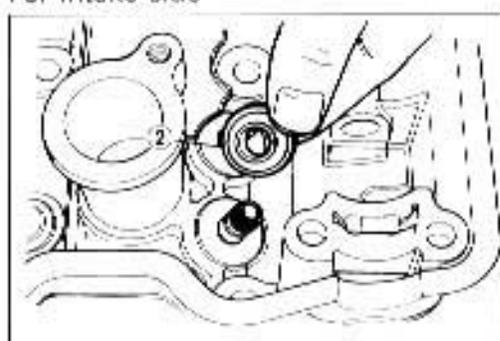

For Exhaust side

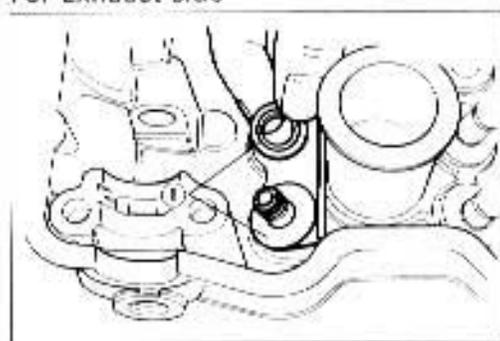

- Insert the valves, with their stems coated with high quality molybdenum disulfide lubricant (SUZUKI MOLY PASTE) all around and along the full stem length without any break.

### CAUTION:

When inserting each valve, take care not to damage the lip of the stem seal.

### 99000-25140: SUZUKI MOLY PASTE

- Install the valve springs with the small-pitch portion (A) facing cylinder head. (B) Large-pitch portion.

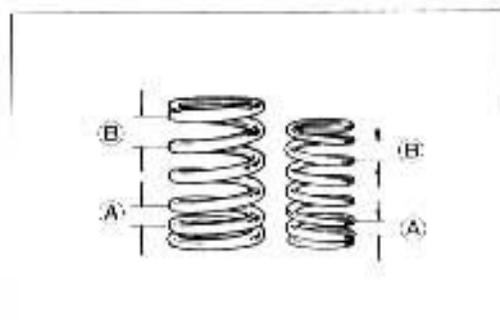
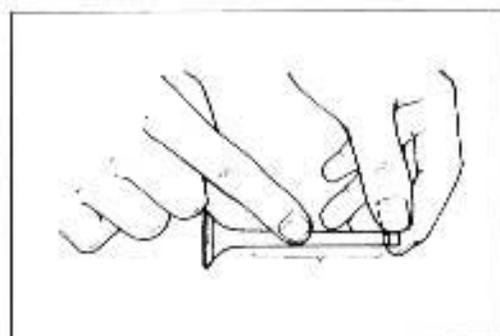

- Put on the valve spring retainer and, using the valve lifter, press down the springs. fit the cotter halves to the stem end, and release the lifter to allow the cotter (1) to wedge in between retainer and stem. Be sure that the rounded lip (2) of the cotter fits snugly into the groove (3) in the stem end.

**09916-14510: Valve lifter**

**09916-14910: Valve lifter attachment**

**09916-84510: Tweezers**

**CAUTION:**

Be sure to restore each spring and valve to their original positions.

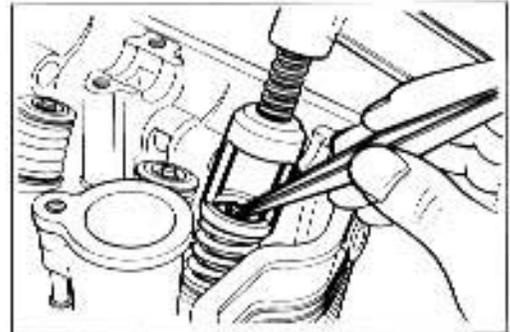
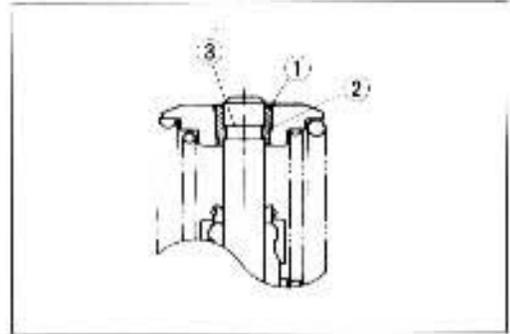

**CAMSHAFT**

Both camshafts should be checked for runout and also for wear of cams and journals if the engine has been noted as giving abnormal noise or vibration or lack power output. Any of these conditions may be caused by camshafts worn down or distorted to the service limit.

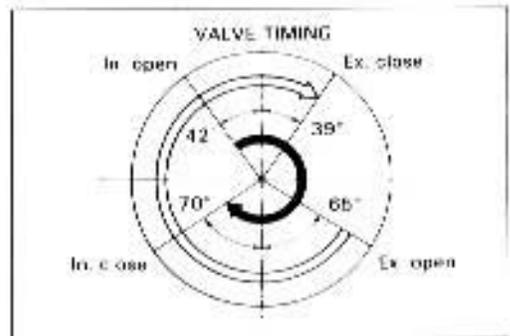

The exhaust camshaft can be distinguished from that of the intake by the embossed letters "EX" (for exhaust) as against letters "IN" (for intake).

Similarly, the right end can be distinguished by the notch from the left end.

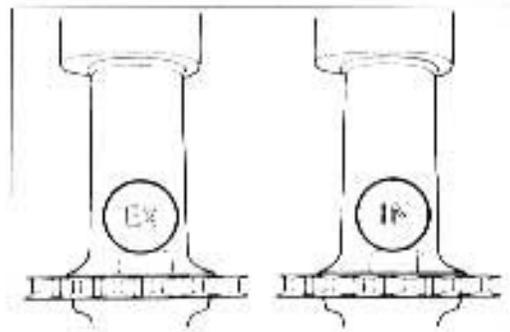
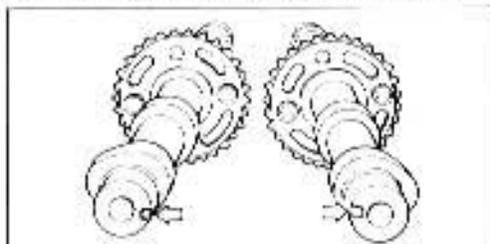

**CAM WEAR**

Worn-down cams are often the cause of mistimed valve operation resulting in reduced power output.

The limit of cam wear is specified for both intake and exhaust cams in terms of cam height (H), which is to be measured with a micrometer. Replace camshafts if found worn down to the limit. (Continued on next page.)

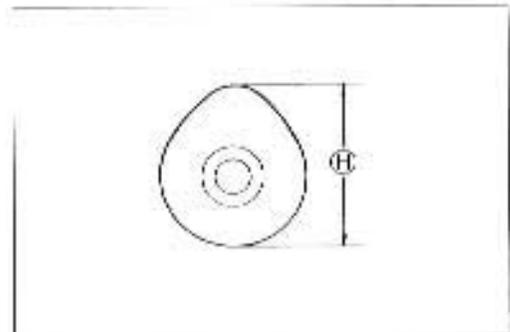

**09900-20202: Micrometer (25 - 50 mm)**



**Cam height** 

**Service Limit** Intake cams : 33.580 mm (1.3220 in)  
 Exhaust cams: 33.240 mm (1.3087 in)

**CAMSHAFT JOURNAL WEAR**

Determine whether or not each journal is worn down to the limit by measuring the oil clearance with the camshaft installed in place. Use the plastigauge<sup>®</sup> 1. to read the clearance at the widest portion, which is specified as follows:

**Camshaft-Journal oil clearance (IN & EX)**

**Service Limit:** 0.150 mm (0.0059 in)  
**09900-22301: Plastigauge (Not available in U.S.A.)**

**NOTE:**

*Install each holder to their original positions. (page 3 - 66)*

Tighten the camshaft holder bolts evenly and diagonally to the specified torque.

**Tightening torque:** 8 - 12 N·m  
 (0.8 - 1.2 kg·m, 6.0 - 8.5 lb-ft)

**NOTE:**

*Do not rotate the camshafts with the plastigauge in place.*

Remove the camshaft holders, and read the width of the compressed plastigauge with envelope scale. This measurement should be taken at the widest part.

If the camshaft journal oil clearance measured exceeds the limit, measure the inside diameter of the camshaft journal holder and outside diameter of the camshaft journal. Replace the camshaft or cylinder head depending upon which one exceeds the specification.

**Standard**

**Journal holder I.D. (IN & EX):** 22.012 - 22.025 mm  
 (0.8666 - 0.8671 in)

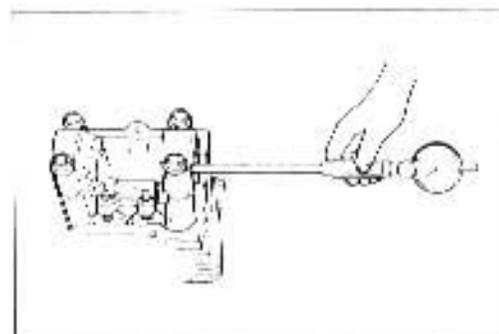
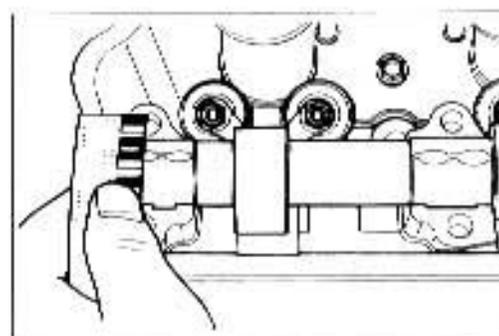
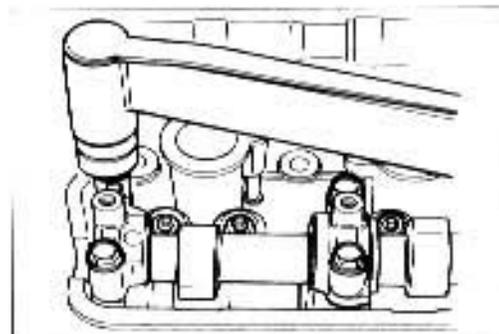
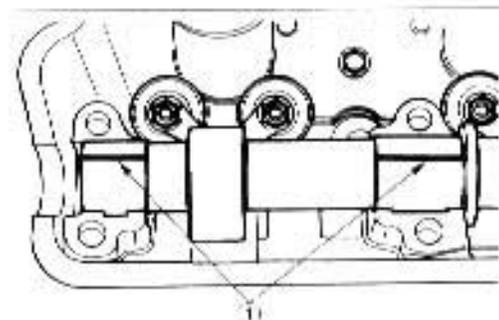

09900-20205: Micrometer (0 – 25 mm)

#### Standard

Camshaft journal O.D. (IN & EX): 21.959 – 21.980 mm  
(0.8645 – 0.8654 in)

## CAMSHAFT RUNOUT

Measure the runout with a dial gauge. Replace the camshaft if the runout exceeds the limit.

Camshaft runout (IN & EX)

Service Limit: 0.1 mm (0.004 in)

09900-20606: Dial gauge (1/100 mm, 10 mm)

09900-20701: Magnetic stand (Not available in U.S.A.)

09900-21304: V-block (100 mm)

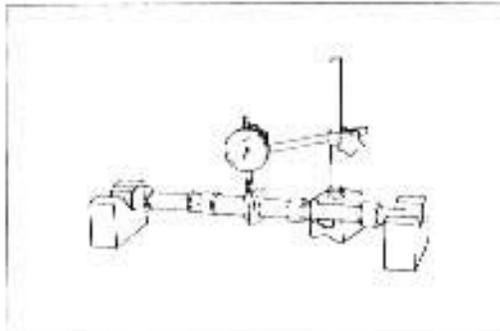
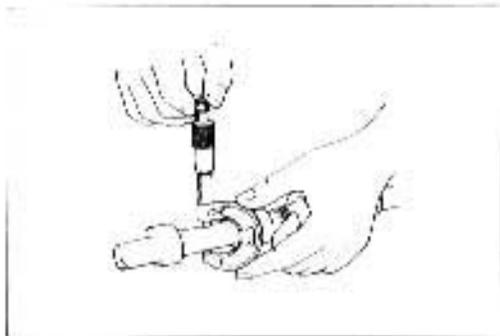

## CAM SPROCKET

The fixed position of each cam sprocket on each camshaft is determined by arrow mark "3" (on INTAKE sprocket) or arrow marks "1" and "2" (on EXHAUST sprocket) located (as shown) in reference to the notch ① in the right end of each camshaft.

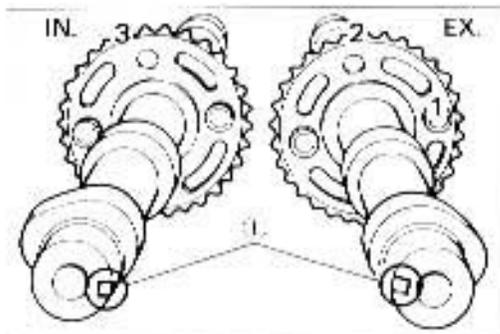

## REASSEMBLY

- Apply THREAD LOCK SUPER "1303" to the threads of cam sprocket bolts, and tighten them to the following torque value:

99000-32030: THREAD LOCK SUPER "1303"

Tightening torque: 24 – 26 N·m

(2.4 – 2.6 kg-m, 17.5 – 19.0 lb-ft)

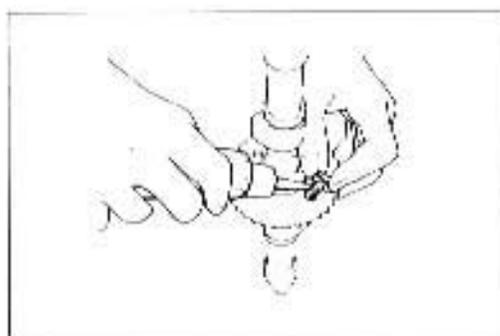

## CAM CHAIN TENSIONER

The cam chain tensioner is maintained at the proper tension by an automatically adjusted tensioner.

Unlock the ratchet mechanism ①, and move the push rod ② in place to see if it slides smoothly. If any stickiness is noted or ratchet mechanism is faulty, replace the cam chain tensioner assembly with a new one.

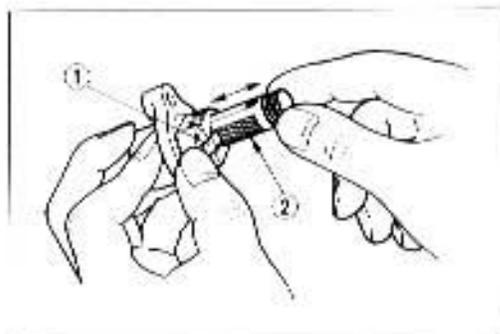

## CAM CHAIN IDLER

Rotate the sprocket by hand to inspect for an abnormal noise and a smooth rotation. If defect is found, replace the cam chain idler assembly with a new one.

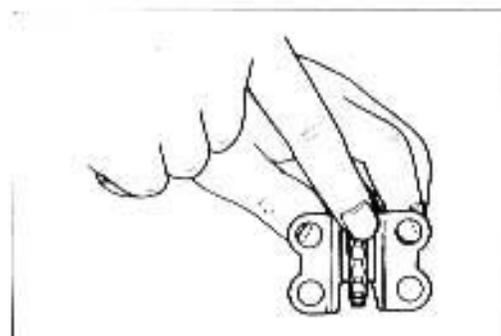

## CAM CHAIN 20-PITCH LENGTH

Pull the chain tight to remove any slack, then using vernier calipers, measure the 20-pitch length of cam chain. If it measures more than the limit, replace the cam chain.

**Service Limit: 158.0 mm (6.22 in)**

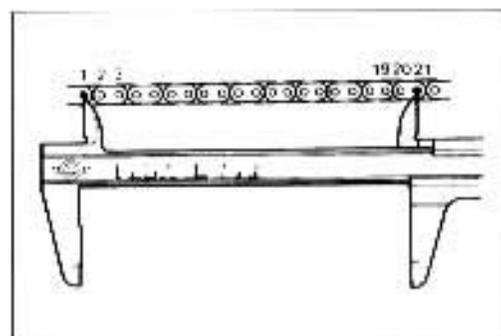

## CAM CHAIN GUIDE

### NOTE:

When replacing the cam chain guide, apply **SUZUKI THREAD LOCK SUPER "1303"** to threads of bolt.

**99000-32030: THREAD LOCK SUPER "1303"**

Cam chain guide

mounting bolt: **4 - 7 N·m**  
(**0.4 - 0.7 kg·m, 3.0 - 5.0 lb·ft**)

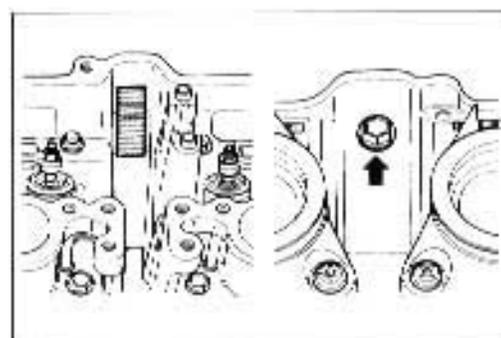

## CYLINDER BLOCK DISTORTION

Check the gasketed surface of the cylinder block for distortion with a straightedge and thickness gauge, taking a clearance reading at several places as indicated. If the largest reading at any position of the straightedge exceeds the limit, replace the cylinder block.

**09900-20803: Thickness gauge**

Cylinder distortion specification

**Service Limit: 0.2 mm (0.008 in)**

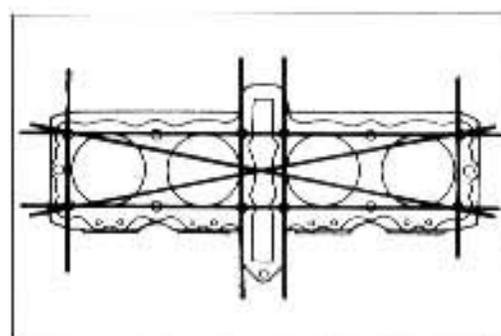

## CYLINDER BORE

Measure the cylinder bore diameter at six places. If any one of the measurements exceeds the limit, overhaul the cylinder and replace the piston with an oversize piston. The remaining cylinders must be also rebored accordingly. Otherwise, the imbalance might cause excess vibration.

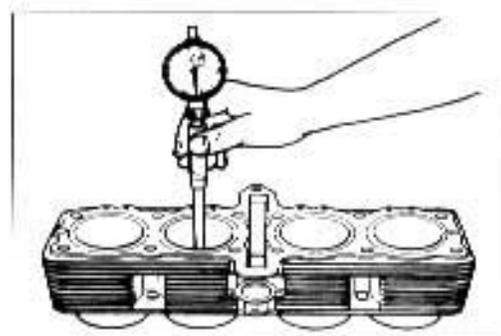

**Cylinder bore**

Service Limit : 78.080 mm (3.0740 in)

09900-20508: Cylinder gauge set

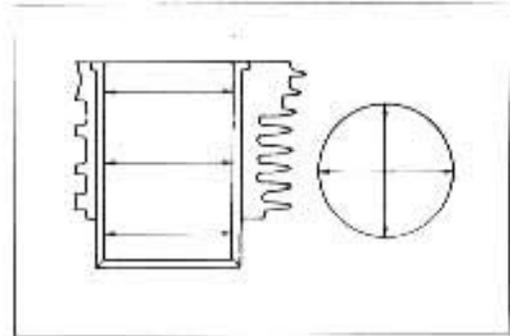
**PISTON DIAMETER**

Using a micrometer, measure the piston's outside diameter at the place shown in Fig. If the measurement is less than the limit, replace the piston.

Service Limit : 77.880 mm (3.0661 in)

09900-20204: Micrometer (75 - 100 mm)

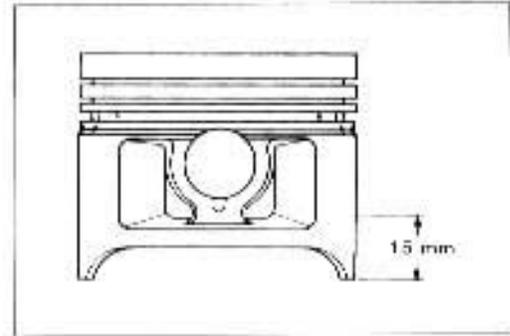
**PISTON-CYLINDER CLEARANCE**

As a result of the above measurement, if the piston clearance exceeds the following limit, overhaul the cylinder and use an oversize piston, or replace both cylinder and piston.

Service Limit : 0.12 mm (0.0047 in)

Piston oversize: 0.5, 1.0 mm

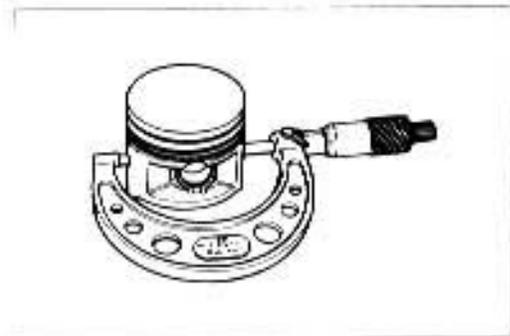
**PISTON RING-GROOVE CLEARANCE**

Using a thickness gauge, measure the side clearances of the 1st and 2nd rings. If any of the clearances exceeds the limit, replace both piston and piston rings.

09900-20803: Thickness gauge

**Piston ring-groove clearance**

Service Limit 1st : 0.18 mm (0.007 in)

2nd: 0.15 mm (0.006 in)

**Piston ring groove width**

Standard 1st & 2nd: 1.01 - 1.03 mm (0.039 - 0.040 in)

Oil : 2.01 - 2.03 mm (0.079 - 0.080 in)

**Piston ring thickness**

Standard

1st & 2nd: 0.97 - 0.99 mm (0.038 - 0.039 in)

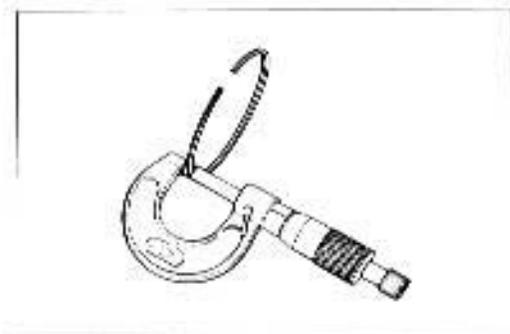
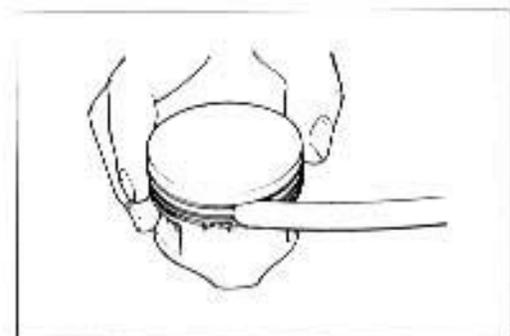

## PISTON RING FREE END GAP AND PISTON RING END GAP

Before installing piston rings, measure the free end gap of each ring using vernier calipers. Next, fit the ring in the cylinder, and measure each ring end gap using a thickness gauge. If any ring has an excess end gap, replace the ring.

### Piston ring free end gap

**Service Limit** 1st: 8.0 mm (0.31 in)  
2nd: 9.2 mm (0.36 in)

09900-20102: Vernier calipers

### Piston ring end gap

**Service Limit** 1st: 0.7 mm (0.03 in)  
2nd: 1.0 mm (0.04 in)

09900-20803: Thickness gauge



### Oversize piston ring

The following two types of oversize piston rings are used. They bear the following identification numbers.

	1st	2nd
0.5 mm	N50	2N50
1.0 mm	N100	2N100

### Oversize oil ring

The following two types of oversize oil rings are available as optional parts. They bear the following identification marks.

SIZE	COLOR
STD	Painted red
0.5 mm O.S.	Painted blue
1.0 mm O.S.	Painted yellow

### Oversize side rail

Just measure out side diameter to identify the size.

## PISTON PIN AND PIN BORE

Using a small bore gauge, measure the piston pin bore inside diameter, and using a micrometer, measure the piston pin outside diameter. If the difference between these two measurements is more than the limits, replace both piston and piston pin.

### Piston pin bore I.D.

**Service Limit:** 20.030 mm (0.7886 in)

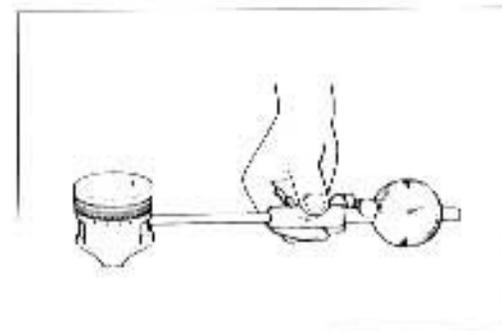
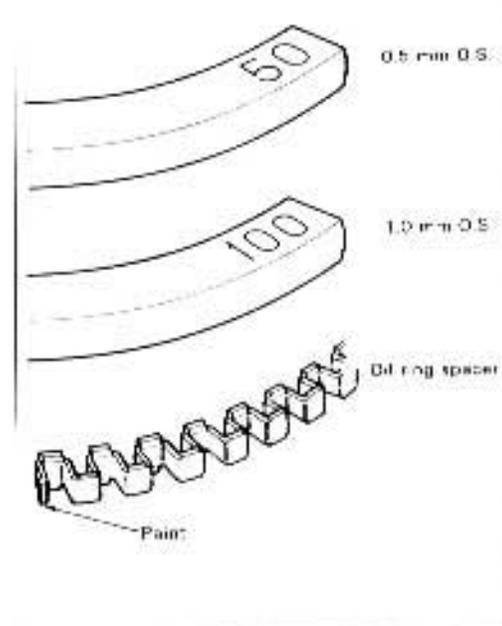

Using a micrometer, measure the piston pin outside diameter at three positions.

**Piston pin O.D.**

**Service Limit: 19.980 mm (0.7866 in)**

**09900-20205: Micrometer (0 - 25 mm)**

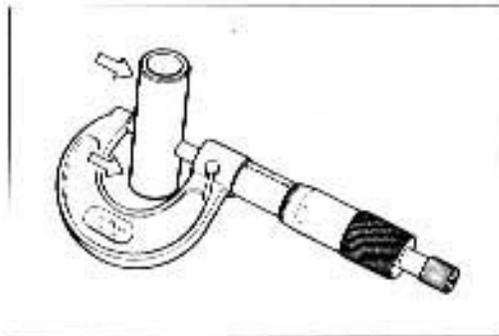

### CONROD SMALL END I.D.

Using a small bore gauge, measure the conrod small end inside diameter.

**09900-20602: Dial gauge (1/1000 mm, 1 mm)**

**09900-22403: Small bore gauge (18 - 35 mm)**  
(Not available in U.S.A.)

**Conrod small end I.D.**

**Service Limit: 20.040 mm (0.7890 in)**

If the conrod small end inside diameter exceeds the above-mentioned limit, replace the conrod.

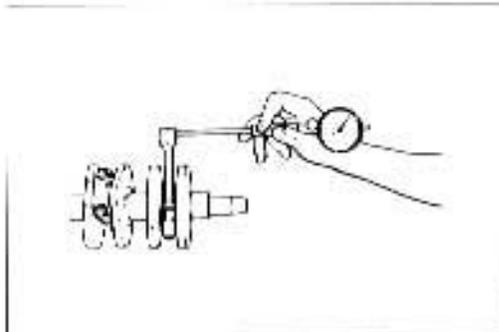

### CONROD BIG END SIDE CLEARANCE

Check the conrod side clearance by using a thickness gauge. If the clearance exceeds the limit, replace conrod or crankshaft.

**Service Limit: 0.3 mm (0.01 in)**

**09900-20803: Thickness gauge**

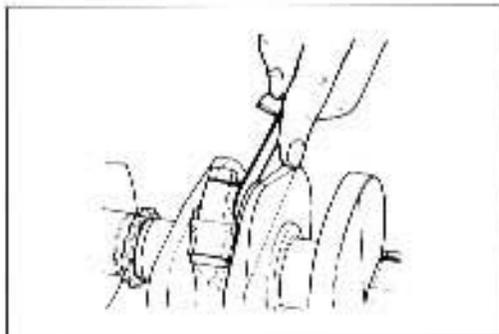

**Standard**

**Big end width: 20.95 - 21.00 mm (0.825 - 0.827 in)**

**Standard**

**Crank pin width: 21.10 - 21.15 mm (0.831 - 0.833 in)**

**09900-20205: Micrometer (0 - 25 mm)**

**09900-20605: Dial calipers (10 - 34 mm)**  
(Not available in U.S.A.)

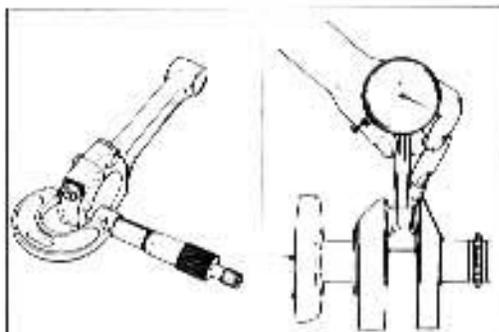

### CONROD-CRANK PIN BEARING SELECTION

- Loosen the bearing cap nuts, and tap the bolt end lightly with plastic hammer to remove the bearing cap.
- Remove the rods, and mark them to identify the cylinder position.
- Inspect the bearing surfaces for any sign of fusion, pitting, burn, or flaws. If any, replace them with a specified set of bearings.

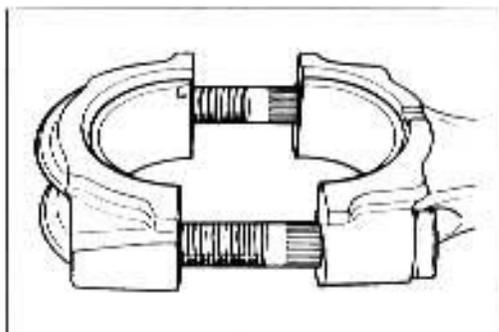

**NOTE:**

Never try to remove or loosen the conrod cap bolts due to their possible loosening in the rod. Once displaced, the bearing cap will not be fitted properly.

- Place the plastigauge axially on the crank pin avoiding the oil hole, at TDC or BDC side as shown.
- Tighten the bearing cap with two-step torque values.

**Initial tightening torque: 22 – 28 N·m**

**(2.2 – 2.8 kg·m, 16.0 – 20.0 lb·ft)**

**Final tightening torque: 49 – 53 N·m**

**(4.9 – 5.3 kg·m, 35.5 – 38.5 lb·ft)**

**09900-22301: Plastigauge**

**(Not available in U.S.A.)**

**NOTE:**

When fitting bearing cap to crank pin, be sure to discriminate one end from the other, namely front and rear.

**NOTE:**

Never rotate the crankshaft or conrod when a piece of Plastigauge is in the clearance.

- Remove the caps, and measure the width of compressed plastigauge with envelope scale. This measurement should be taken at the widest part.

**Crank pin bearing oil clearance**

**Standard: 0.032 – 0.056 mm (0.0013 – 0.0022 in)**

**Service Limit: 0.080 mm (0.0031 in)**

- If oil clearance exceeds the service limit, select the specified bearings from the following table.
- Check the corresponding rod I.D. code number (1), "1" or "2".
- Check the corresponding crank pin O.D. code number (2), "1", "2" or "3".

**Bearing selection table**

Conrod I.D. (1)	Code	Crank pin O.D. (2)		
		1	2	3
	1	Green	Black	Brown
	2	Black	Brown	Yellow

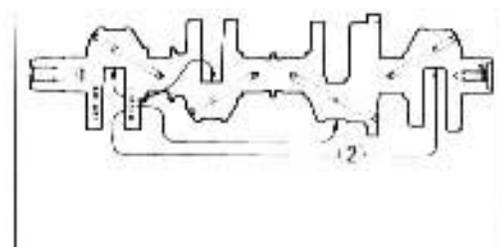
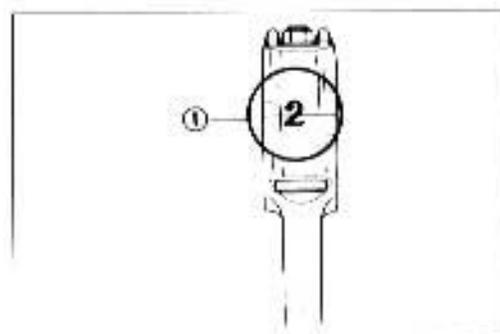
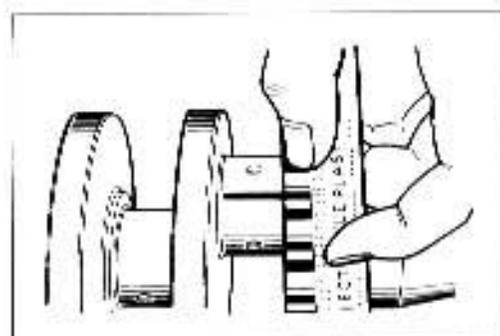
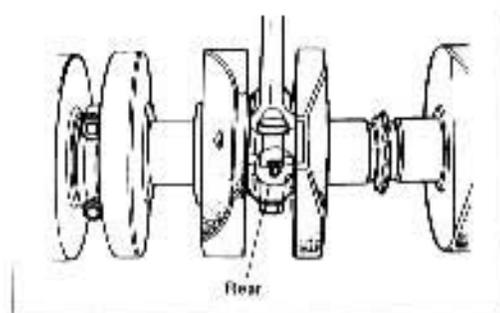
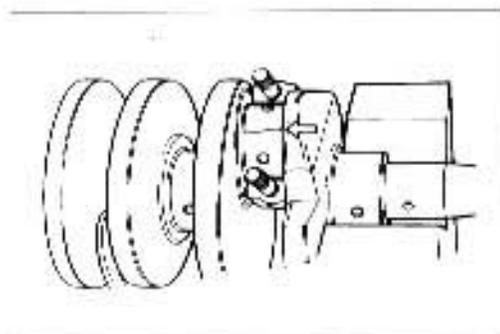

**Conrod I.D. specification**

Code	I.D. specification
1	41.000 – 41.008 mm (1.6142 – 1.6145 in)
2	41.008 – 41.016 mm (1.6145 – 1.6148 in)

**Crank pin O.D. specification**

Code	O.D. specification
1	37.992 – 38.000 mm (1.4957 – 1.4961 in)
2	37.984 – 37.992 mm (1.4954 – 1.4957 in)
3	37.976 – 37.984 mm (1.4951 – 1.4954 in)

**09900-20202: Micrometer (25 – 50 mm)****Bearing thickness**

Color (Part No.)	Thickness
Green (12164-48B00-OA0)	1.480 – 1.484 mm (0.0583 – 0.0584 in)
Black (12164-48B00-0B0)	1.484 – 1.488 mm (0.0584 – 0.0586 in)
Brown (12164-48B00-0C0)	1.488 – 1.492 mm (0.0586 – 0.0587 in)
Yellow (12164-48B00-0D0)	1.492 – 1.496 mm (0.0587 – 0.0589 in)

**CAUTION:**

Bearing should be replace as a set.

**BEARING ASSEMBLY**

- When fitting the bearings to the bearing cap and conrod, be sure to fix the stopper part first, and press in the other end.

- Apply engine oil or SUZUKI MOLY PASTE to the crank pin and bearing surface.

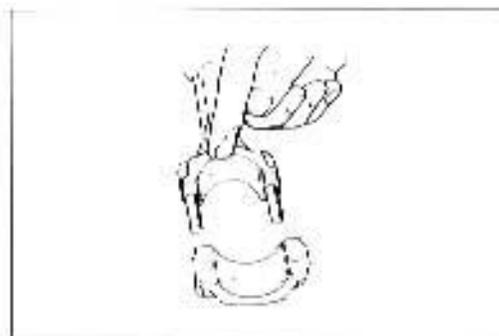
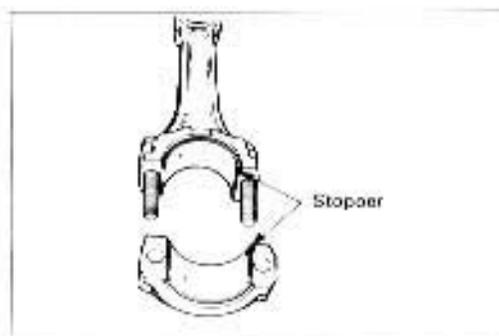
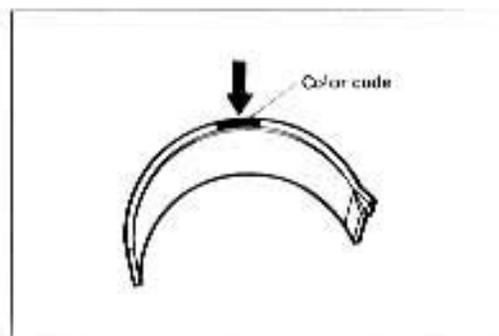
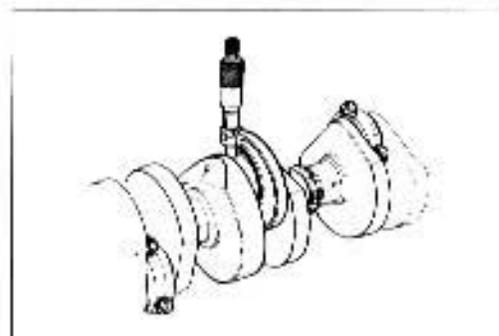
**99000-25140: SUZUKI MOLY PASTE**



- When mounting the conrod on the crankshaft, make sure that numeral figure ① of the conrod faces rearward.
- Tighten the conrod fitting nuts with specified torque.

**Tightening torque:** 49 – 53 N·m  
(4.9 – 5.3 kg·m, 35.5 – 38.5 lb-ft)

- Check the conrod movement for smooth turning.

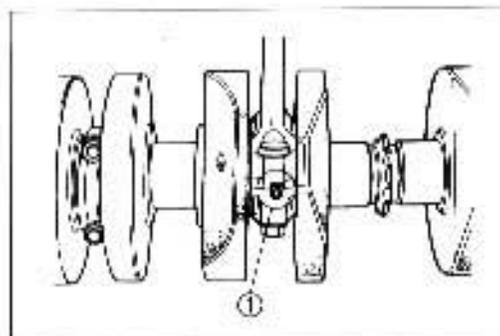

## CRANKCASE-CRANKSHAFT BEARING SELECTION

- Inspect each bearing of upper and lower crankcases for any damage.

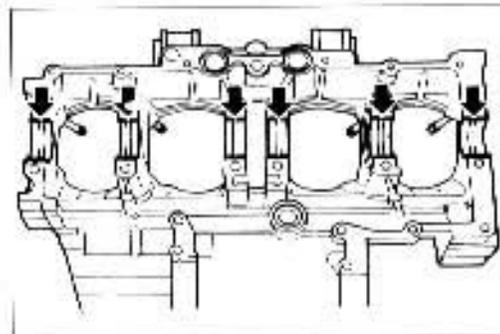

- Place the plastigauge on each crankshaft journal in the usual manner.

**09900-22301: Plastigauge**  
(Not available in U.S.A.)

### NOTE:

*Do not place the plastigauge on the oil hole, and do not rotate the shaft when plastigauge is in place.*

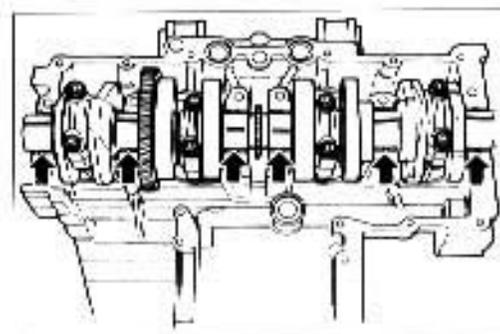

- Mate the lower crankcase with the upper crankcase, and tighten the crankshaft tightening bolts with specified torque value in the indicated order.

Tightening torque	Initial Tightening	Final Tightening
8 mm bolt	13 N·m (1.3 kg·m) (9.5 lb-ft)	20 – 24 N·m (2.0 – 2.4 kg·m) (14.5 – 17.5 lb-ft)

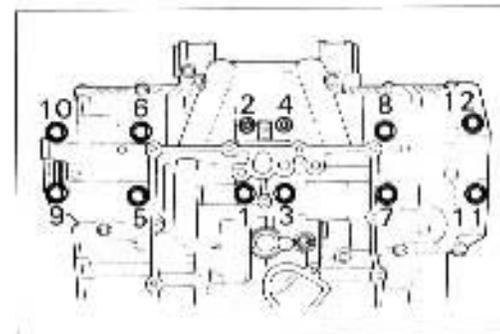

- Remove the lower crankcase, and measure the width of compressed plastigauge in the usual manner.

**Crank journal bearing oil clearance**  
Standard: 0.020 – 0.044 mm (0.0008 – 0.0017 in)  
Service Limit: 0.08 mm (0.0031 in)

- If the width at the widest part exceeds the limit, replace the set of bearings with new ones by referring to the selection table.

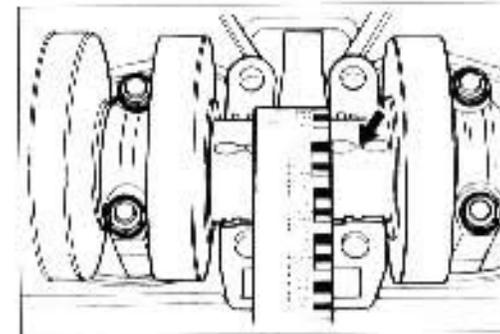

- Check the corresponding crankcase journal I.D. code number (1), "A" or "B" which are stamped on the rear of upper crankcase.
- Check the corresponding crankshaft journal O.D. code number (2), "A", "B" or "C" which are stamped on the crankshaft.

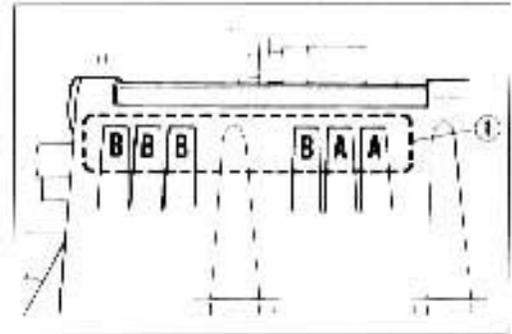

#### Bearing selection table

	Code	Crankshaft O.D. (2)		
		A	B	C
<b>Crankcase I.D. (1)</b>	A	Green	Black	Brown
	B	Black	Brown	Yellow

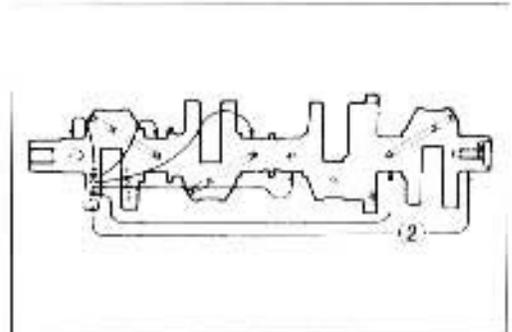

#### Crankcase I.D. specification

Code	I.D. specification
A	39.000 - 39.008 mm (1.5354 - 1.5357 in)
B	39.008 - 39.016 mm (1.5357 - 1.5361 in)

#### Crankshaft journal O.D. specification

Code	O.D. specification
A	35.992 - 36.000 mm (1.4170 - 1.4173 in)
B	35.984 - 35.992 mm (1.4167 - 1.4170 in)
C	35.976 - 35.984 mm (1.4164 - 1.4167 in)

09900-20202: Micrometer (25 - 50 mm)

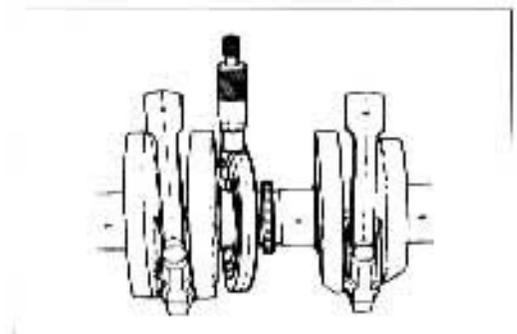

**Bearing thickness specification****(Grooved bearing with oil hole ... For lower case)**

Color (Part No.)	Specification
Green (12229-06B00-0A0)	1.486 – 1.490 mm (0.0585 – 0.0587 in)
Black (12229-06B00-0B0)	1.490 – 1.494 mm (0.0587 – 0.0588 in)
Brown (12229-06B00-0C0)	1.494 – 1.498 mm (0.0588 – 0.0590 in)
Yellow (12229-06B00-0D0)	1.498 – 1.502 mm (0.0590 – 0.0591 in)

**NOTE:**

- \* Grooved bearings have the same specification as the Grooved bearing with oil hole.
- \* These parts numbers are shown as follows. 12229-06B10-XXX. (Grooved bearing)

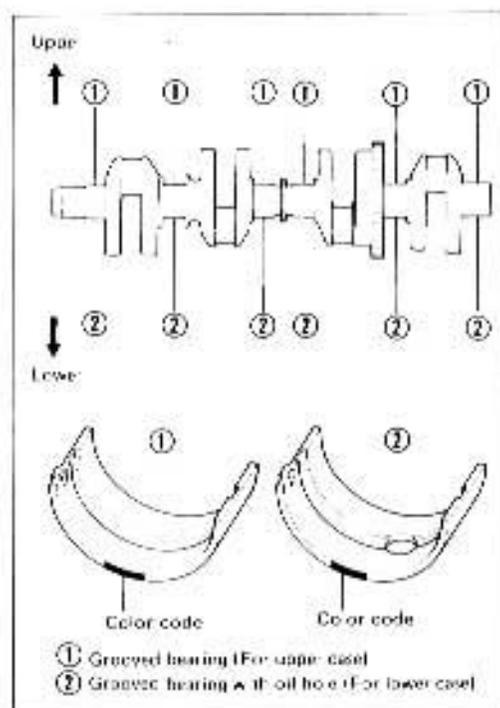
**CRANKSHAFT THRUST CLEARANCE**

- With the crankshaft, right-side thrust bearing and left-side thrust bearing inserted in the upper crankcase, use a thickness gauge to measure the thrust clearance on the left-side.

**NOTE:**

Push the crankshaft to the starter clutch side, so that there is no clearance on the right-side thrust bearing.

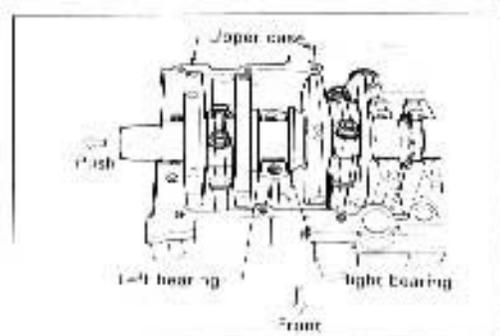
**Thrust clearance**

**Standard: 0.05 – 0.13mm (0.002 – 0.005 in)**

If the thrust clearance exceeds the standard range, adjust the thrust clearance by the following procedures:

- Remove the right-side thrust bearing and measure its thickness with a micrometer. If the thickness of the right side thrust bearing is below standard, replace with a new bearing and once again perform the thrust clearance measurement listed above, checking to make sure it is within standard.

**Right-side thrust bearing thickness**

**Standard: 2.42 – 2.44 mm (0.095 – 0.096 in)**

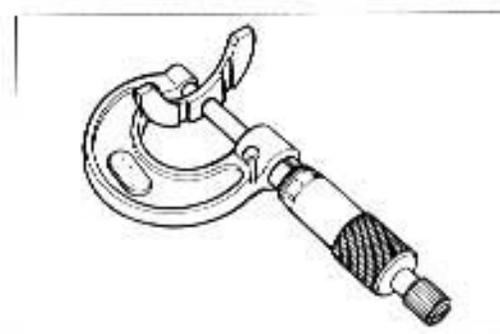
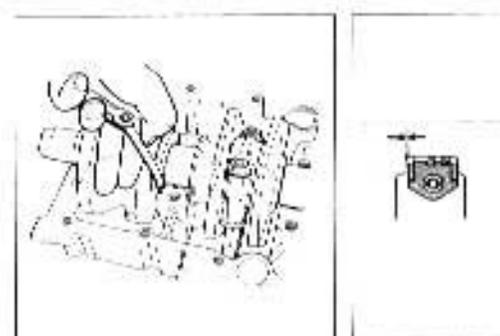

- If the right-side thrust bearing is within the standard range, reinsert the right-side thrust bearing and remove the left-side thrust bearing.
- As shown in the illustration, use a thickness gauge to measure the clearance before inserting of the left-side thrust bearing, and select a left-side thrust bearing from the selection table.

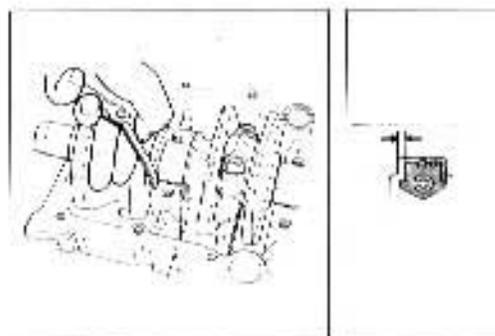

Thrust bearing selection table

Clearance before inserting left-side thrust bearing	Color (Part No.)	Thrust bearing thickness	Thrust clearance
2.44 - 2.49 mm (0.096 - 0.098 in)	Black (12228-48B00-0H0)	2.36 - 2.38 mm (0.093 - 0.094 in)	0.05 - 0.13 mm (0.002 - 0.005 in)
2.49 - 2.54 mm (0.098 - 0.100 in)	Green (12228-48B00-0E0)	2.42 - 2.44 mm (0.095 - 0.096 in)	
2.54 - 2.59 mm (0.100 - 0.102 in)	Red (12228-48B00-0C0)	2.46 - 2.48 mm (0.097 - 0.098 in)	

- After selecting a left-side thrust bearing, insert it and again perform the thrust clearance measurement to make sure it falls within the standard range.

**NOTE**

Right-side thrust bearing has the same specification as the Green of left-side thrust bearing.

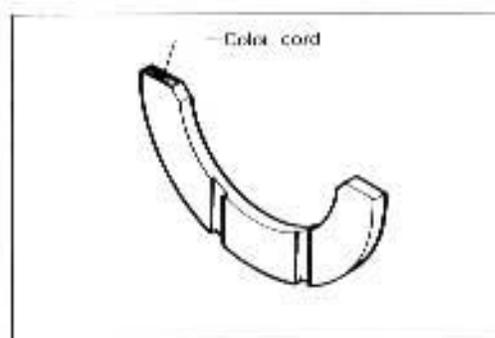
**CRANKSHAFT RUNOUT**

Support the crankshaft with "V" blocks as shown, with the two end journals resting on the blocks. Set up the dial gauge, as shown, and rotate the crankshaft slowly to read the runout. Replace the crankshaft if the runout is greater than the limit.

09900-20606: Dial gauge (1/100 mm, 10 mm)

09900-20701: Magnetic stand

09900-21304: V-block (100 mm)

Not available in U.S.A.

Crankshaft runout

Service Limit: 0.05 mm (0.002 in)

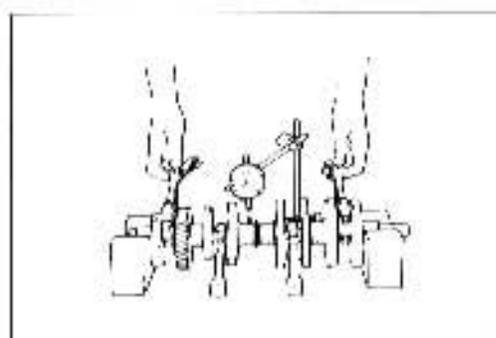

## CLUTCH DIAPHRAGM SPRING

Measure the free height of each diaphragm spring with a vernier calipers. If each diaphragm spring height is not within the specified limit, replace it with a new one.

**09900-20102: Vernier calipers**

**Service Limit: 3.1 mm (0.12 in)**

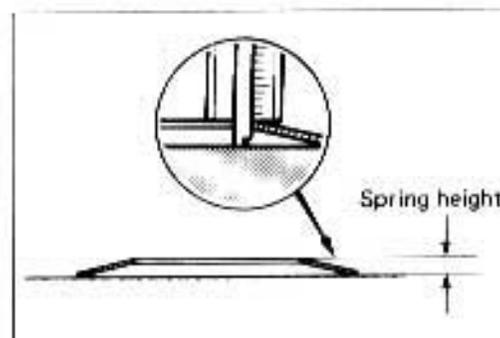

## CLUTCH DRIVE AND DRIVEN PLATES

Measure the total thickness of drive and driven plates by compressing them with a 5 kg load.

### NOTE:

*Wipe off the engine oil from the drive and driven plates with a clean rag and put them one by one on the surface plate. If the total thickness of drive and driven plates is not within the specification, replace the drive plates with new ones or measure each drive plate thickness and driven plate distortion.*

Total thickness of drive and driven plates	46.3 ± 0.4 mm at 5 kg load (1.82 ± 0.02 in at 11.02 lbs load)
--	--

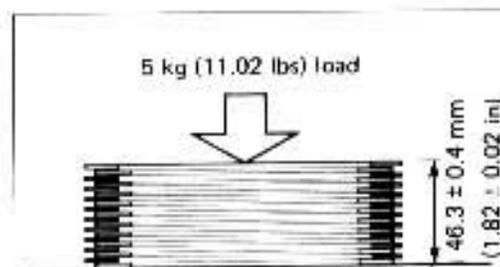

## PARTS SUPPLY DATA

**21400-40C00: Clutch plate assembly**

**21441-48B00: Clutch drive plate**

**21451-48B00: Clutch driven plate**

Measure the thickness of each drive plate with a vernier calipers. If each drive plate is not within the standard range, replace it with a new one.

**09900-20102: Vernier calipers**

### Standard

**Thickness: 2.52 – 2.68 mm (0.100 – 0.106 in)**

Measure each driven plate for distortion with a thickness gauge.

Replace driven plates which exceed the limit.

**09900-20803: Thickness gauge**

**Service Limit: 0.1 mm (0.004 in)**

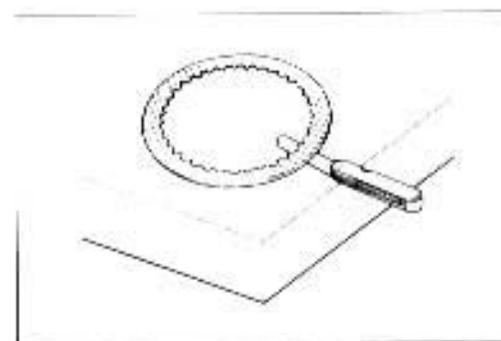
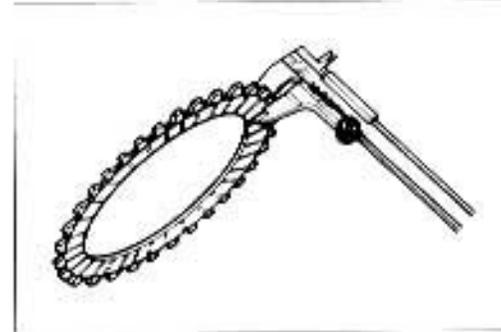

## CLUTCH BEARING

Inspect the clutch release bearing for any abnormality, particularly cracks, to decide whether it can be reused or should be replaced.

Smooth engagement and disengagement of the clutch depends on the condition of this bearing.

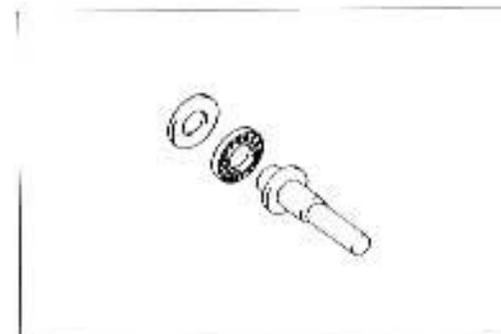

## CLUTCH RELEASE CYLINDER

### DISASSEMBLY

- Remove the clutch hydraulic line by removing the union bolt (1).
- Remove the gearshift lever and engine sprocket cover. (Refer to page 3-8.)

#### NOTE:

Completely wipe off any clutch fluid adhering to any part of motorcycle.

The fluid reacts chemically with paint, plastics, rubber materials, etc.

- Remove the air bleeder valve (2).
- Remove the clutch release cylinder by removing the mounting bolts (3) and piston retainer screws (4).

- Place a rag over the piston to prevent popping up. Force out the piston by using air gun.

#### CAUTION:

Do not use high pressure air to prevent piston damage.

### INSPECTION

Inspect the clutch cylinder bore wall for nicks, scratches or other damage. Inspect the oil seal for damage and wear. Inspect the piston surface for any scratches or other damage.

### REASSEMBLY

Reassemble the clutch cylinder in the reverse order of disassembly and by taking the following steps:

#### CAUTION:

- \* Wash the clutch cylinder components with fresh brake fluid before reassembly.
- \* Never use cleaning solvent or gasoline to wash them.
- \* Apply brake fluid to the cylinder bore and piston to be inserted into the bore.

### OIL PUMP

#### CAUTION:

Do not attempt to disassemble the oil pump assembly. The oil pump is available only as an assembly.

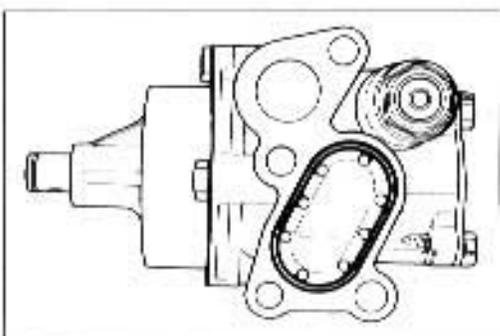
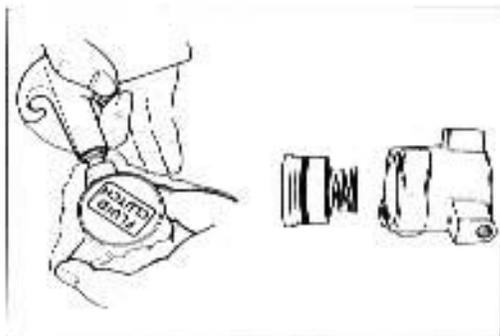
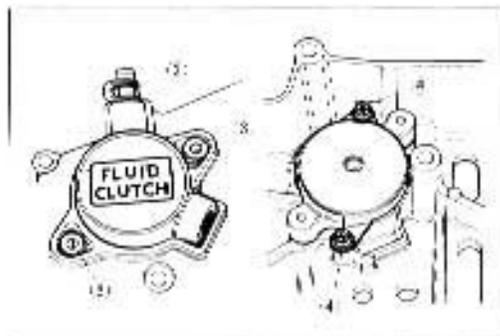
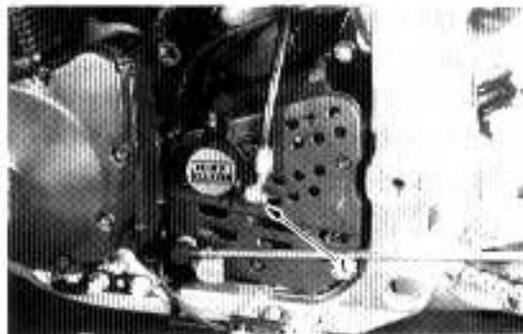

## TRANSMISSION

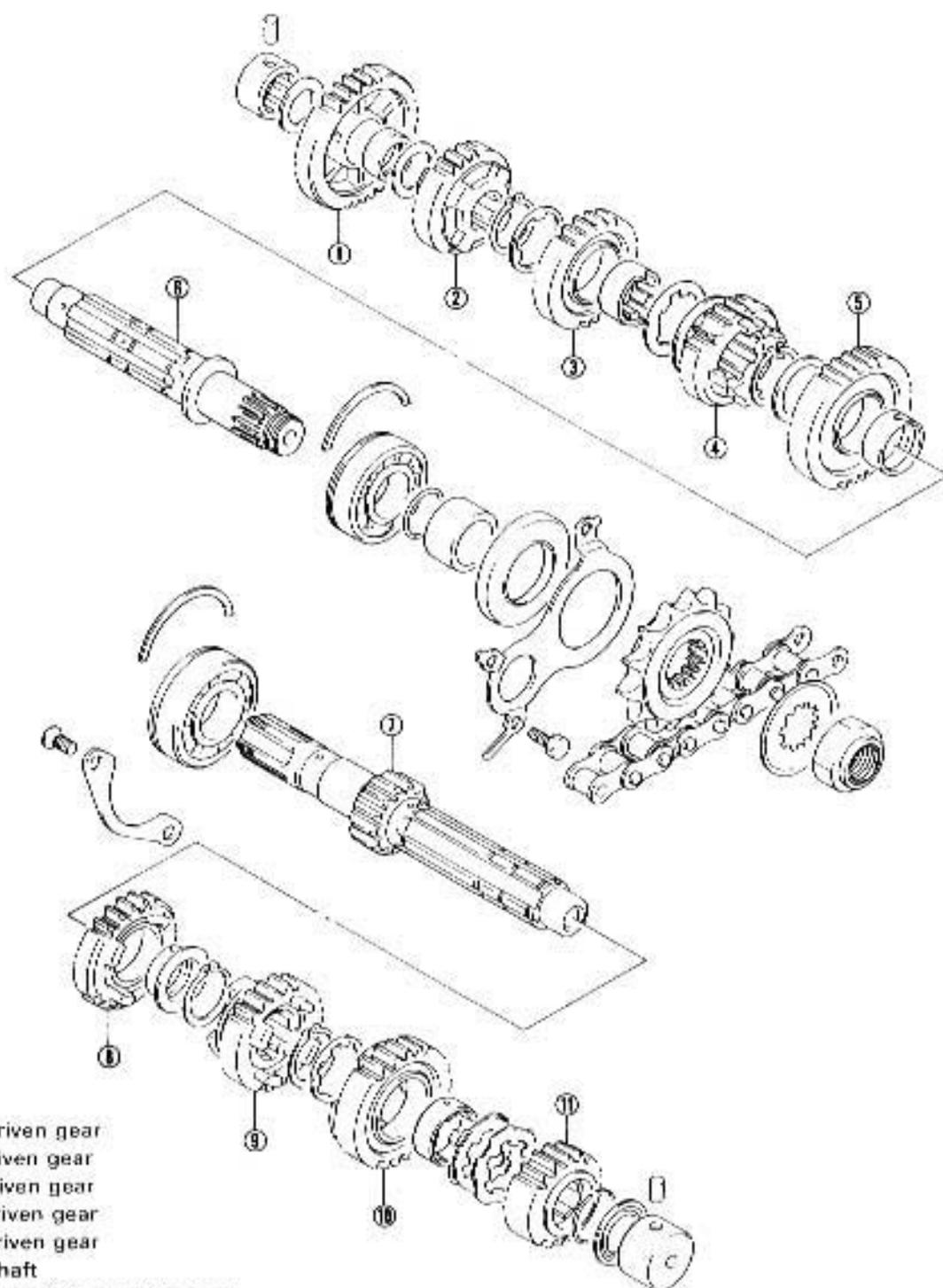

- ① Low driven gear
- ② 4th driven gear
- ③ 3rd driven gear
- ④ Top driven gear
- ⑤ 2nd driven gear
- ⑥ Driveshaft
- ⑦ Countershaft/Low drive gear
- ⑧ 4th drive gear
- ⑨ 3rd drive gear
- ⑩ Top drive gear
- ⑪ 2nd drive gear

## COUNTERSHAFT

### DISASSEMBLY

- Remove the left end bearing (1) and oil seal (2).



- Remove the Top drive gear circlip (3) from the groove and slide the circlip (3) toward the 3rd drive gear (4).

#### 09900-06104: Snap ring pliers

- Slide the Top drive gear (5) toward the 3rd drive gear (4) and remove the pair of the lock washers (6) from the groove and slide the pair of the lock washers (6) and 2nd drive gear (7) toward the Top drive gear (5).

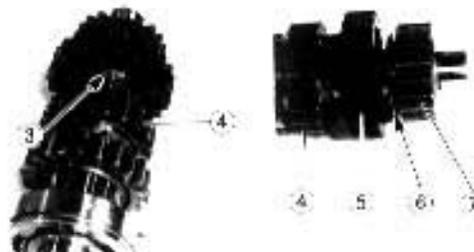

- Remove the 2nd drive gear circlip (8), and then remove the 2nd drive gear (7), Top drive gear (5) and 3rd drive gear (4).

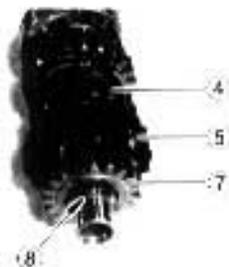

- Remove the 4th drive gear (9) by removing the circlip (10).

#### 09900-06107: Snap ring pliers

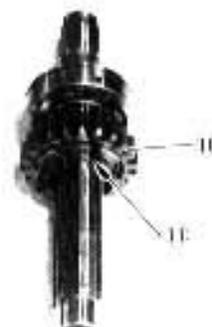

## DRIVESHAFT

### DISASSEMBLY

- Each driven gear on the driveshaft is easily removed by using snap ring pliers.

#### 09900-06107: Snap ring pliers

The order of disassembling is as follows:

- |                       |                      |
|-----------------------|----------------------|
| (1) Right end bearing | (5) Top driven gear  |
| (2) Low driven gear   | (6) 2nd driven gear  |
| (3) 4th driven gear   | (7) Left end bearing |
| (4) 3rd driven gear   | (8) Oil seal         |
|                       | (9) Spacer           |

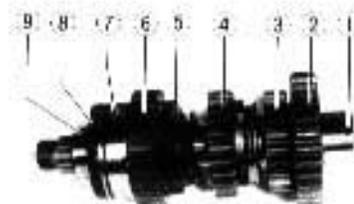



## COUNTERSHAFT AND DRIVESHAFT

### REASSEMBLY

Assemble the countershaft and driveshaft in the reverse order of disassembly. Pay attention to the following points:

#### NOTE:

- \* Before installing the gears, rotate the bearing by hand to inspect for abnormal noise and smooth rotation. Replace the bearing if there is anything unusual.
- \* Before installing the gears, lightly coat moly paste or engine oil to the driveshaft and countershaft.

#### 99000-25140: SUZUKI MOLY PASTE

#### CAUTION:

- \* **Never reuse a circlip.** After a circlip has been removed from a shaft, it should be discarded, a new circlip must be installed.
- \* **When installing a new circlip,** care must be taken not to expand the end gap larger than required to slip the circlip over the shaft.
- \* **After installing a circlip,** always insure that it is completely seated in its groove and securely fitted.

#### NOTE:

In reassembling the transmission, attention must be given to the locations and positions of washers and circlips. The cross sectional view given here will serve as a reference for correctly mounting the gears, washers and circlips. (Refer to page 3-46.)

- When installing a new circlip, pay attention to the direction of the circlip. Fit it to the side where the thrust is as shown in the illustration.

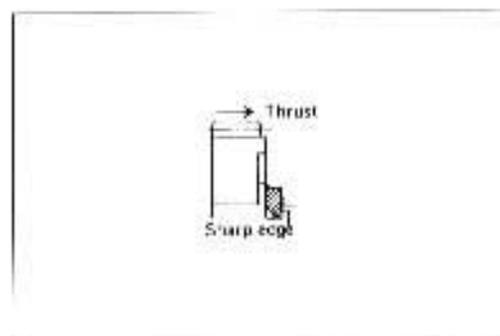

- When installing the gear bushing onto the shaft, align the oil hole (1) of the shaft with the bushing oil hole (2).

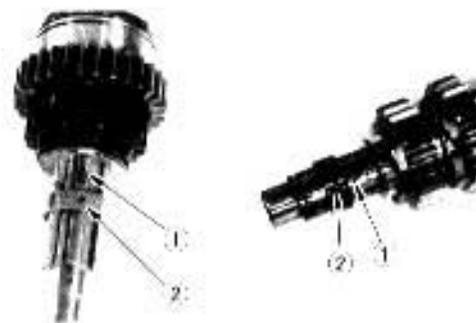

- When installing the pair of the lock washers (3) and (4), be sure to align the three grooves of the lock washer (3) with the three tabs of the lock washer (4).



- Before installing the spacer (5), fit a new O-ring (6) onto the driveshaft.
- Apply grease to the oil seal lip and install it onto the driveshaft.

(For U.S.A. model)

**99000-25030: SUZUKI SUPER GREASE "A"**

(For the other models)

**99000-25010: SUZUKI SUPER GREASE "A"**



## TRANSMISSION

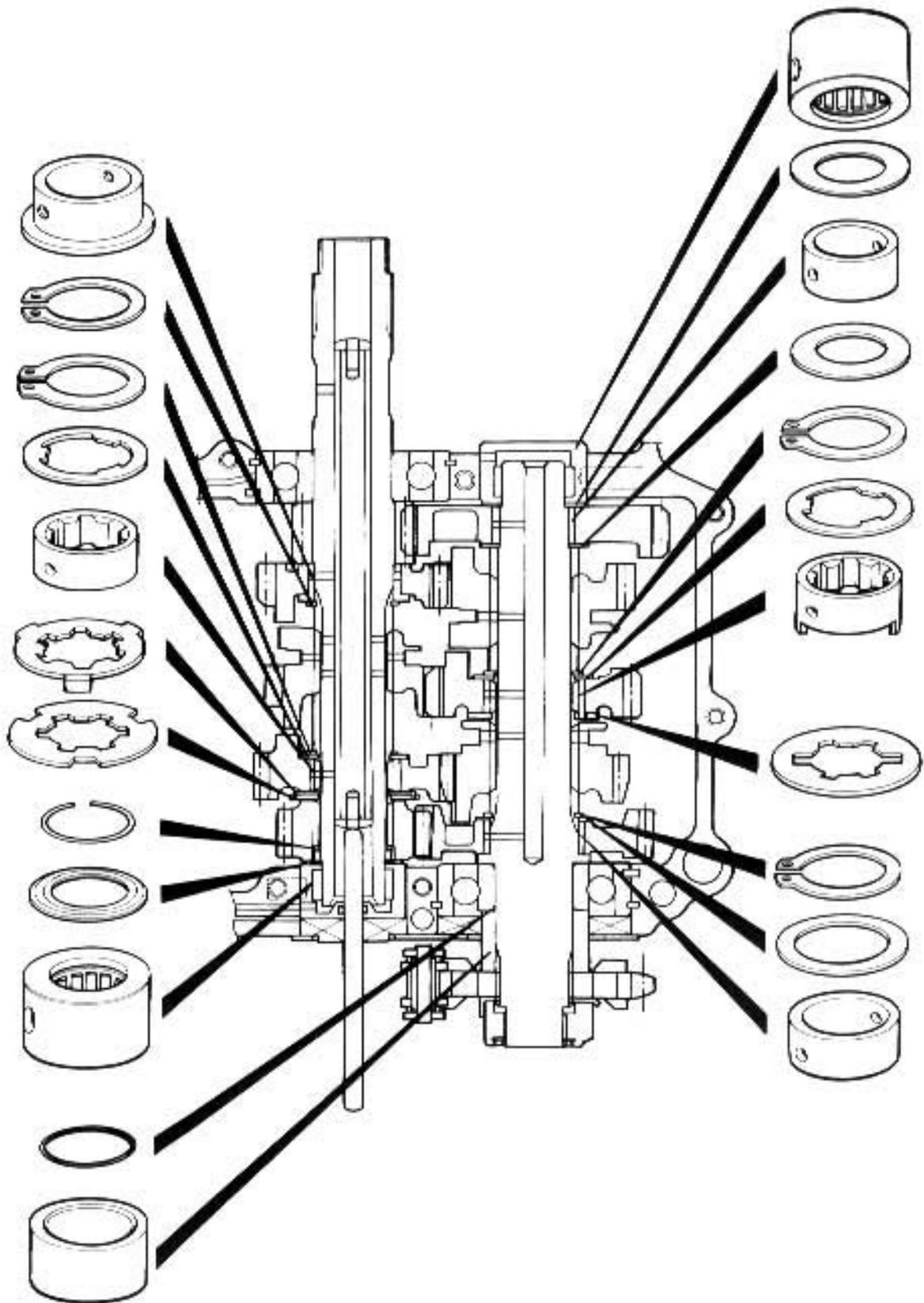

## GEARSHIFT FORK-GROOVE CLEARANCE

Using a thickness gauge, check the gearshift fork clearance in the groove of its gear.

The clearance for each of the three gearshift forks plays an important role in the smoothness and positiveness of the shifting action.

### Gearshift fork-Groove clearance

**Standard** : 0.10 – 0.30 mm (0.004 – 0.012 in)

**Service Limit:** 0.50 mm (0.020 in)

If the clearance checked is noted to exceed the limit specified, replace the fork or its gear, or both.

**09900-20803: Thickness gauge**

**09900-20102: Vernier calipers**

### Shift fork groove width

#### Standard

(No.1, No.2 & No.3): 5.00 – 5.10 mm (0.197 – 0.201 in)

### Shift fork thickness

#### Standard

(No.1, No.2 & No.3): 4.80 – 4.90 mm (0.189 – 0.193 in)

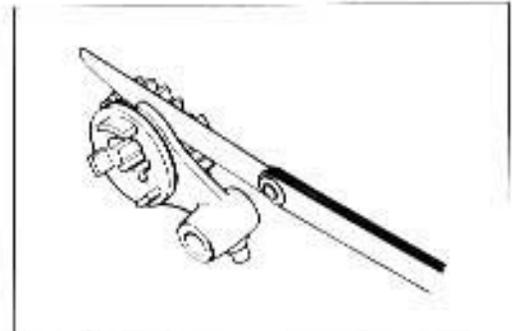

Checking clearance

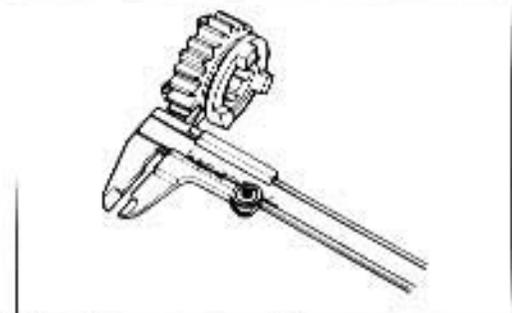

Checking groove width

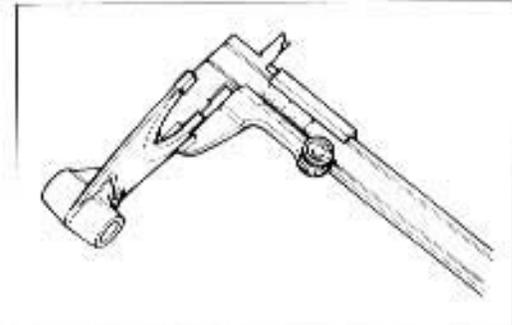

Checking thickness

## ENGINE REASSEMBLY

The engine is reassembled by carrying out the steps of disassembly in the reversed order, but there are a number of steps which demand special descriptions or precautionary measures.

### NOTE:

*Apply engine oil to each running and sliding part before reassembling.*

- Install the gearshift cam related parts.

- ① Gearshift cam
- ② Gearshift cam stopper
- ③ Circlip
- ④ Circlip
- ⑤ Spring

**CAUTION:**

**Always use new circlips ③ and ④.**

- Position the gearshift cam as shown in Fig. so that the gearshift forks and transmission can be installed easily.

**NOTE:**

When installing the cam stopper plate ②, align the pin groove ⑤ with the pin ④ as shown in the Fig.

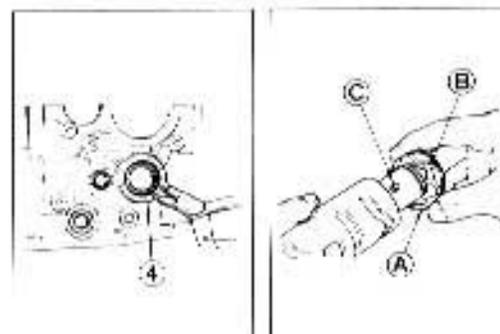
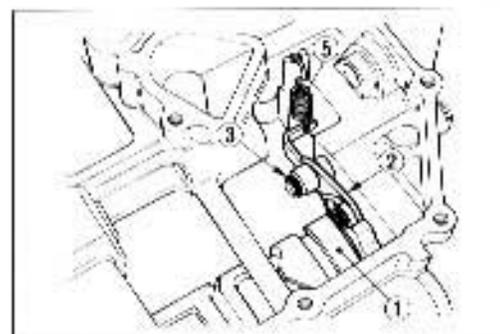

- Install the gearshift forks to the crankcase in the correct positions and directions.

- ① For 4th driven gear
- ② For 3rd drive gear
- ③ For Top driven gear

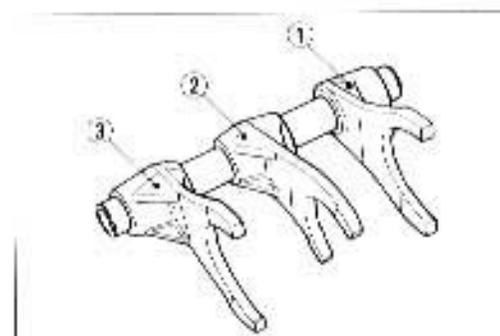

- Fit the O-rings (1) and (2) and dowel pins (3) to the correct positions, as shown in the Figs.

**CAUTION:**

**Replace the O-rings with new ones to prevent oil leakage.**

- Install the oil pump to the lower crankcase with three bolts and tighten them to the specified torque.

**NOTE:**

Apply a small quantity of **THREAD LOCK "1342"** to the bolts.

**99000-32050: THREAD LOCK "1342"**

**Tightening torque: 8 - 12 N·m**

**[0.8 - 1.2 kg-m, 6.0 - 8.5 lb-ft]**

**NOTE:**

Check the oil jets (A) fitted on the lower crankcase for clogging.

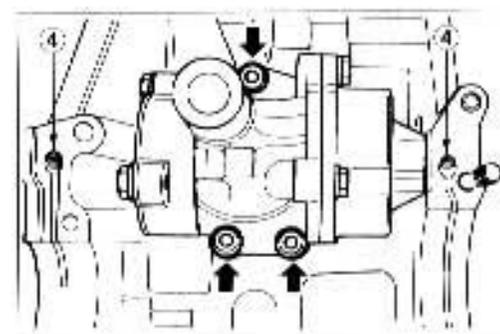
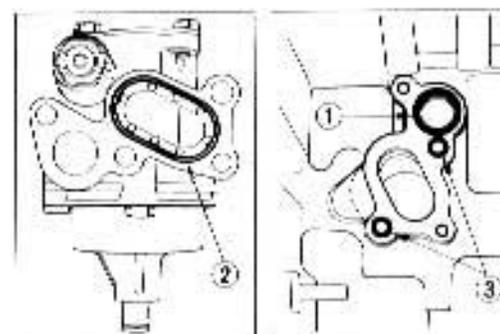

- Fit the bearing pins (5) and C-rings (6) on the upper crankcase.

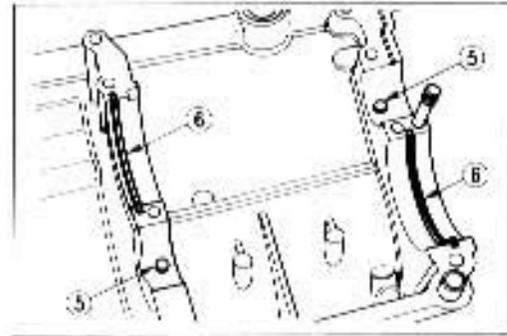

- Install the countershaft assembly and driveshaft assembly on the upper crankcase.

**NOTE:**

- \* Be sure to install the bearing dowel pins (7) in the respective positions.
- \* Install the countershaft end cap to the position (8).
- \* Make sure that the countershaft turns freely while holding the driveshaft. If not, shift the gear which is engaged to the neutral position.

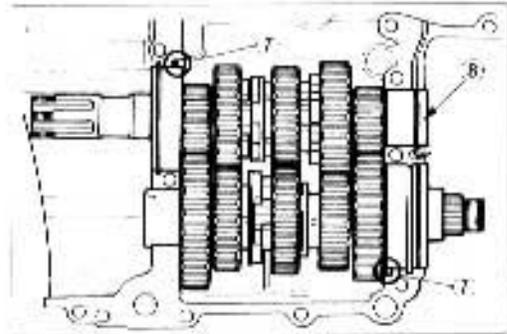

**NOTE:**

Before fitting the crankshaft journal bearings, check the nozzles (1) fitted on the upper crankcase for clogging.

- (1) Nozzle (4 pcs)..... For upper case

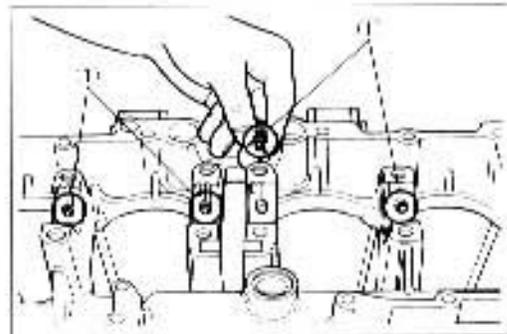

- When fitting the crankshaft journal bearings to the upper and lower crankcases, be sure to fix the stopper part (2) first and press the other end.
- (Refer to page 3-42.)

**CAUTION:**

Do not touch the bearing surfaces with your hands. Grasp by the edge of the bearing shell.

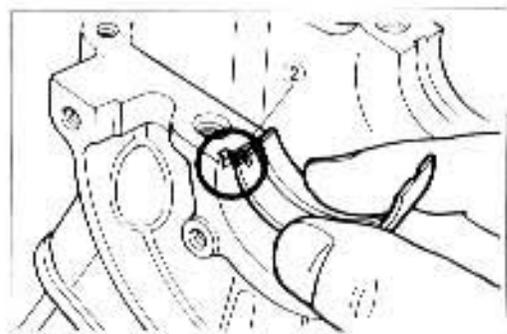

- Install the cam chain guide (3) and two dampers (4) properly.

**NOTE:**

Be sure to face the arrow mark on the damper to the front and rear, not to the left and right.

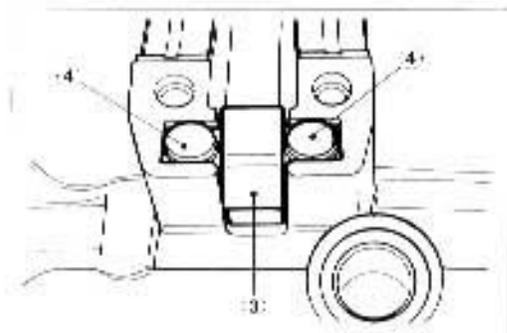

- Fit the O-rings, (5) and (6).

**CAUTION:**

Replace the O-rings with new ones to prevent oil leakage.

- Before installing the crankshaft, apply SUZUKI MOLY PASTE to each journal bearing lightly.

**99000-25140: SUZUKI MOLY PASTE**

- Install the crankshaft with the cam chain to the upper crankcase.
- Insert the right and left-thrust bearings with oil grooved facing the crank web. (Refer to page 3-43.)
- Clean the mating surfaces of the crankcases before matching the upper and lower ones.
- Install the dowel pins to the upper crankcase.
- Apply SUZUKI BOND NO. 1207B to the mating surface of the lower crankcase in the following procedure.

(For U.S.A. model)

**99104-31140: SUZUKI BOND NO. 1207B**

(For the other models)

**99000-31140: SUZUKI BOND NO. 1207B****NOTE:**

Use of SUZUKI BOND NO. 1207B is as follows:

- \* Make surfaces free from moisture, oil, dust and other foreign materials.
- \* Spread on surfaces thinly to form an even layer, and assemble the cases within few minutes.
- \* Take extreme care not to apply any BOND NO. 1207B to the bearing surfaces.
- \* Apply to distorted surface as it forms a comparatively thick film.

- Attach the right oil pipe (A) with No. 1 bolt.
- Place the copper washers over the No. 9 and No. 11 bolts.
- Locate the two allen bolts at position (B) and ten 8-mm bolts.
- Tighten the crankshaft tightening 8-mm bolts in the ascending order of numbers assigned to these bolts, tightening each bolt a little at a time to equalize the pressure. Tighten the lower and upper crankcase securing bolts and nuts to the specified torque values.

Tightening torque	Initial tightening			Final tightening		
	kg-m	N-m	lb-ft	kg-m	N-m	lb-ft
6 mm bolt	0.6	6	4.5	1.3	13	9.5
8 mm bolt	1.3	13	9.5	2.4	24	17.5

**NOTE:**

- \* Install the main oil gallery plug. (Refer to page 3-21.)
- \* Fit up the engine ground wire (C) to the correct position as shown in Fig.

**09914-25811: 6-mm T-type hexagon wrench**

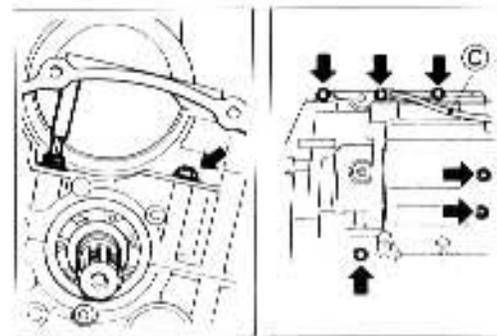
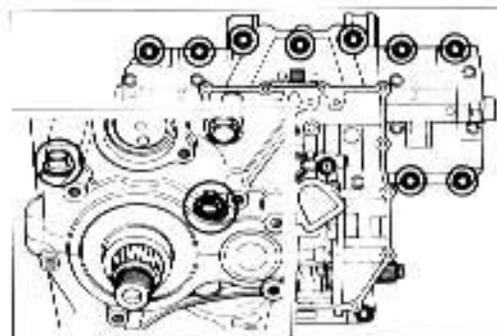
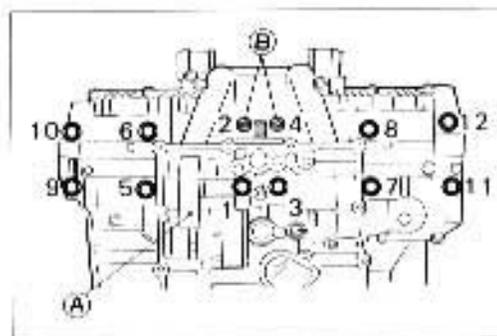
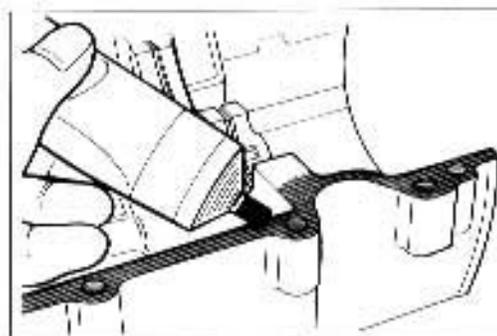
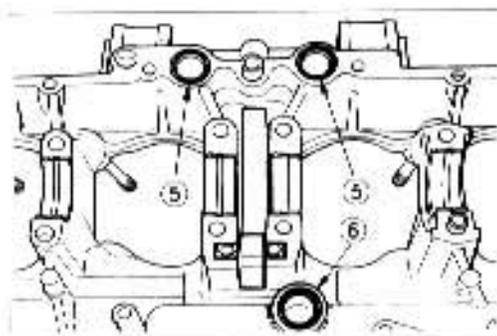

- Attach the left oil pipe (A) with the bolt.
- Fit a new O-ring (1) and shim (2).
- Fit a new gasket and install the oil sump filter to the lower crankcase.

**CAUTION:**

Replace the gasket and O-ring with new ones to prevent oil leakage.

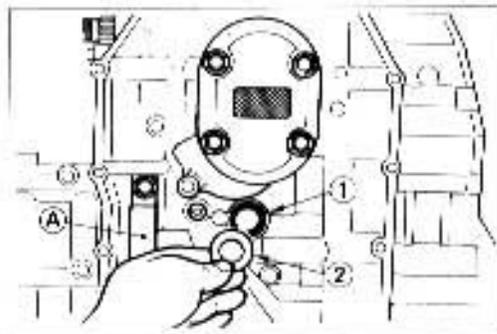

- Seat the washer and install the oil pressure regulator (3) to the oil pan.
- Tighten the regulator to the specified torque.

**Tightening torque:** 25 - 30 N·m

(2.5 - 3.0 kg-m, 18.0 - 21.5 lb-ft)

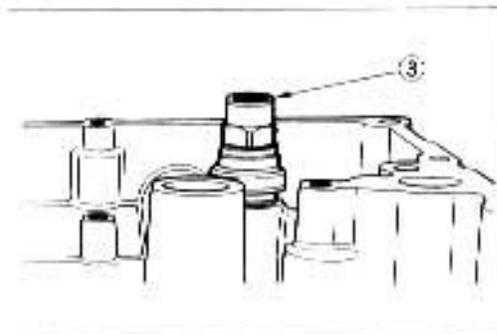

- Fit a new gasket and install the oil pan. Tighten the oil pan bolts to the specified torque.

**Tightening torque:** 12 - 16 N·m

(1.2 - 1.6 kg-m, 8.5 - 11.5 lb-ft)

**NOTE:**

\* Fit a new gasket (A) to the correct position as shown.

**CAUTION:**

Use a new gasket to prevent oil leakage.

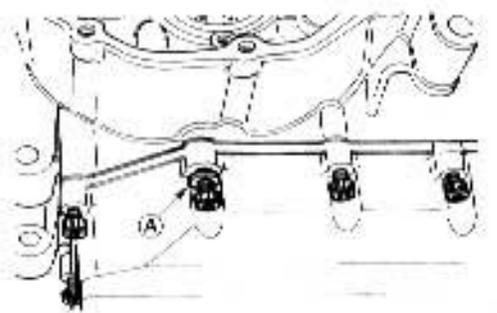

- Tighten the engine oil drain plug to the specified torque. (Refer to page 7-29.)
- Install the countershaft bearing retainer with two screws.

**NOTE:**

Apply a small quantity of **THREAD LOCK "1342"** to the two screws.

**99000-32050: THREAD LOCK "1342"**

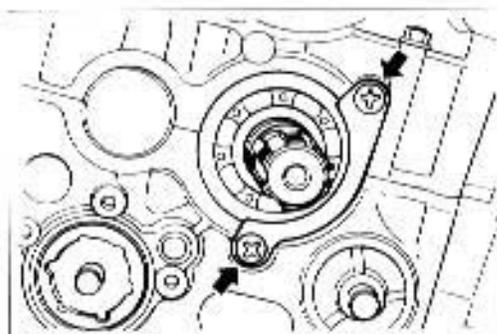

- Install each gear shifting pawl into the cam driven gear. The large shoulder (A) must face to the outside as shown.
- When installing the cam guide (1) and pawl lifter (2), apply a small quantity of **THREAD LOCK "1342"** to the screws (3).

**99000-32050: THREAD LOCK "1342"**

**09900-09003: Impact driver set**

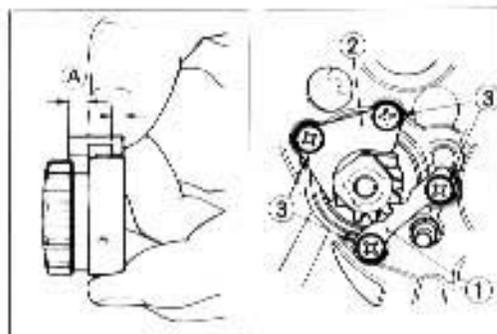



- Install the gearshift shaft with the center of the gear on shaft aligned the center of gearshift cam driven gear.
- Install the washer and fix the gearshift shaft with the clip.

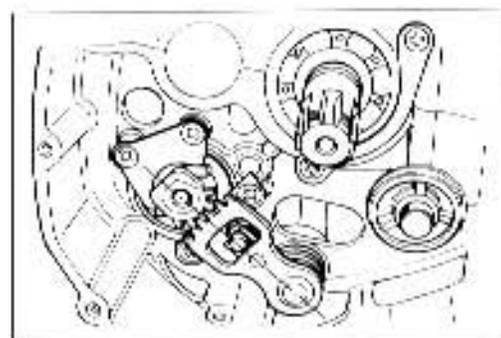
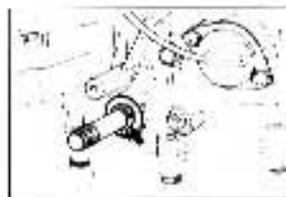

- Install the washer ①, pin ②, oil pump driven gear ③ and washer ④.
- Fix the oil pump driven gear with the circlip.

**09900-06107: Snap ring pliers**

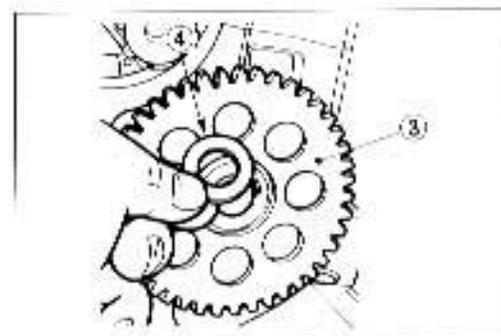
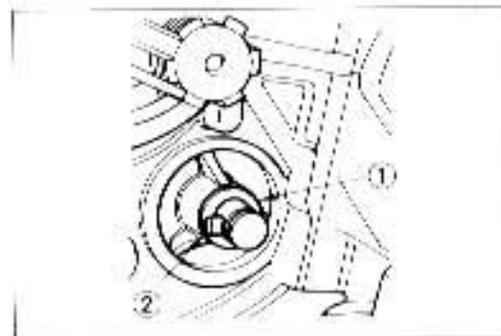

- Install the thrust washer ① onto the countershaft.

**NOTE:**

*Flat surface of washer is positioned outside.*

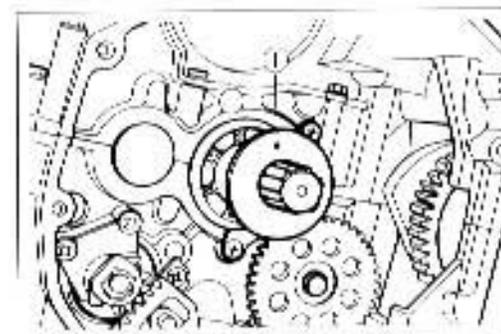

- Install the generator/oil pump drive gears onto the primary driven gear.

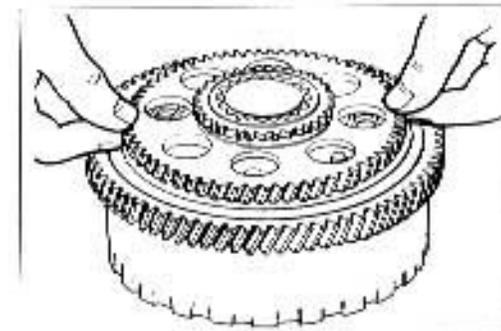

- Install the primary driven gear assembly onto the countershaft, and apply engine oil to the needle bearing and spacer.
- Install the thrust washer (2) onto the countershaft.

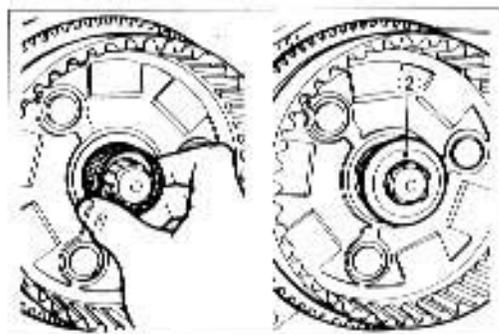

- Install the wave washer seat (3) and wave washer (4) onto the clutch sleeve hub correctly.
- Install the clutch sleeve hub onto the countershaft.

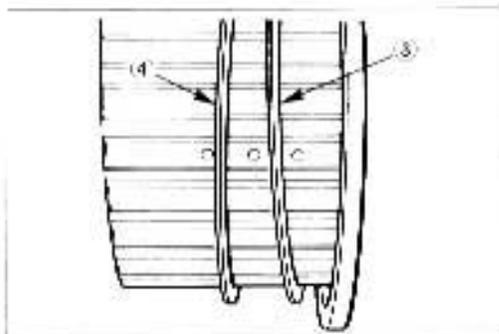

- Tighten the clutch sleeve hub nut to the specified torque by using the torque wrench and clutch sleeve hub holder.

**09920-50710: Clutch sleeve hub holder**

**Tightening torque: 140 - 160 N·m**

**(14.0 - 16.0 kg·m, 101.5 - 115.5 lb-ft)**

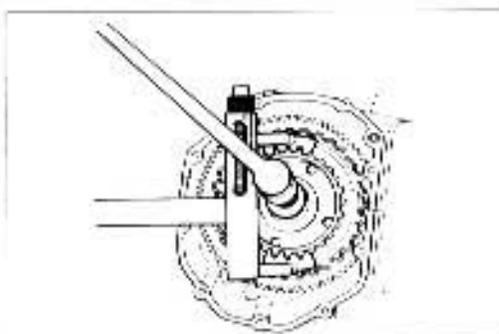

- Insert the clutch driven plates and drive plates one by one into the clutch sleeve hub in the prescribed order, driven plate first.
- Put the clutch pressure plate onto the clutch sleeve hub.
- Put the clutch diaphragm spring seat (5) and clutch diaphragm springs (6) onto the clutch pressure plate properly.

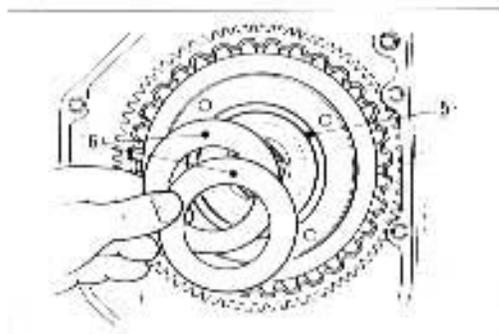

- Tighten the clutch diaphragm spring holder nut to the specified torque by using the special tools.

**09920-34820: Clutch pressure plate holder**

**09941-58010: 50 mm socket wrench**

**Tightening torque: 90 - 110 N·m**

**(9.0 - 11.0 kg·m, 65.0 - 79.5 lb-ft)**

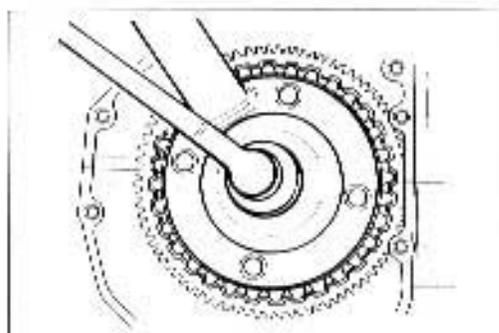

- Install the clutch push rod (1), clutch push piece (2), bearing (3) and thrust washer (4) into the countershaft.

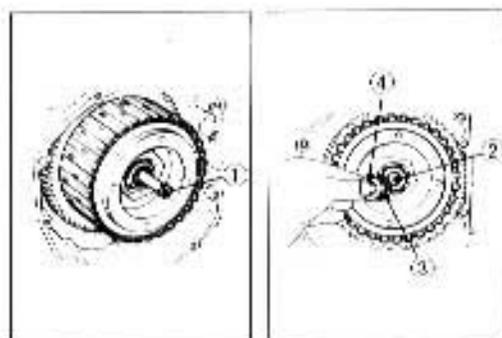

- Fix the pressure plate lifter with the circlip.

**09900-06108: Snap ring pliers**

**NOTE:**

When fitting the circlip, make sure that the sharp edge of the circlip faces outside.

- Coat SUZUKI BOND NO. 1207B lightly to the mating surfaces between upper and lower crankcases as shown in the Fig.

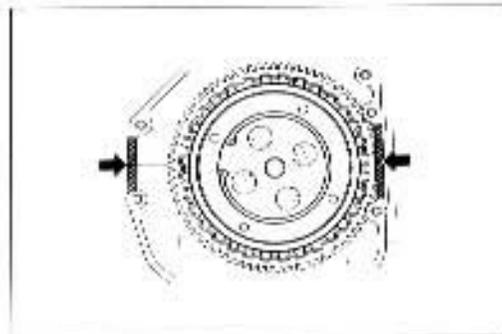

[For U.S.A. model]

**99104-31140: SUZUKI BOND NO. 1207B**

[For the other models]

**99000-31140: SUZUKI BOND NO. 1207B**

- Install the dowel pins, a new gasket and clutch cover.
- Tighten the cover bolts securely.

**NOTE:**

Fit the two gaskets to the clutch cover bolts (6) correctly as shown in the Fig.

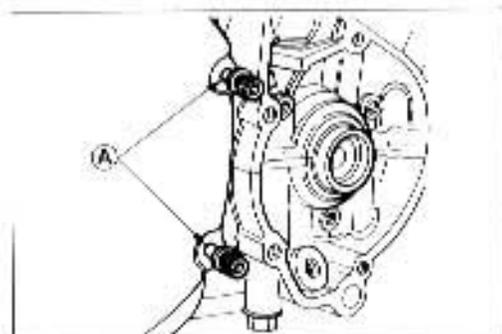

**CAUTION:**

Use only new gasket to prevent oil leakage.

**NOTE:**

When replacing the oil pressure switch, apply SUZUKI BOND NO. 1207B to its thread lightly.

[For U.S.A. model]

**99104-31140: SUZUKI BOND NO. 1207B**

[For the other models]

**99000-31140: SUZUKI BOND NO. 1207B**

- Install the signal generator stator with three screws.
- Connect the oil pressure switch lead wire to the oil pressure switch terminal.
- Make sure to fit the slot (1) on the back surface of the signal generator rotor over the locating pin (2) at the end of crankshaft.

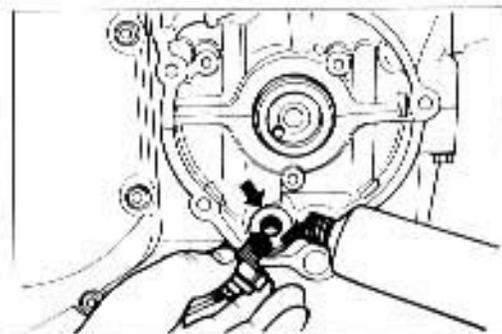

**NOTE:**

BOND NO. 1207B should be applied to the groove of the signal generator lead wire grommet (3).

[For U.S.A. model]

**99104-31140: SUZUKI BOND NO. 1207B**

[For the other models]

**99000-31140: SUZUKI BOND NO. 1207B**

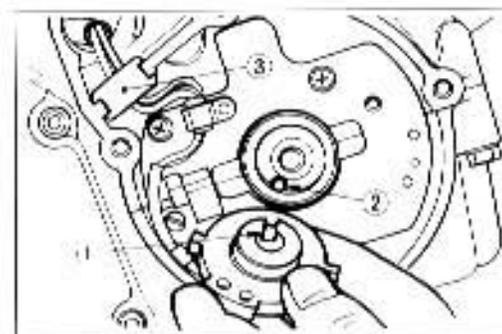

- Hold the crankshaft turning nut and tighten the rotor bolt to the specified torque using 6-mm hexagon wrench.

**09900-00410: Hexagon wrench set (Not available in U.S.A.)**

**Tightening torque: 25 – 35 N·m**

**(2.5 – 3.5 kg·m, 18.0 – 25.5 lb·ft)**

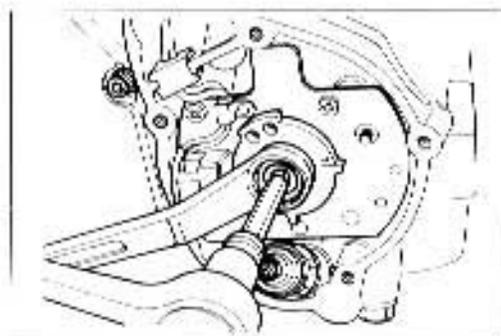

- Pass the signal generator lead wire through upper crankcase as shown in the Fig.

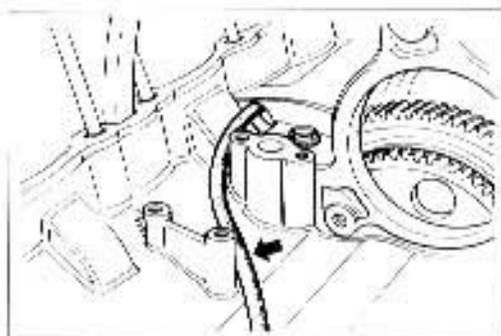

- Install the neutral position indicator switch with two screws.

**NOTE:**

*When installing the neutral position indicator switch, be sure to locate the spring, ① switch contact ② and O-ring ③.*

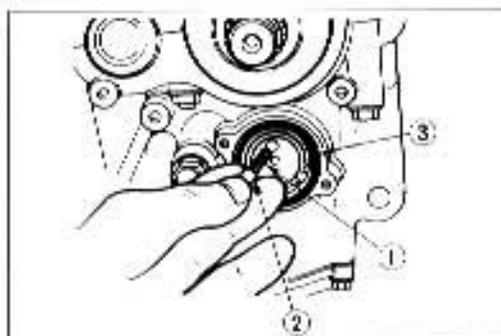

- Install the oil seal retainer with four bolts and bend the lock portion of the retainer.
- Insert the clutch push rod into the countershaft.

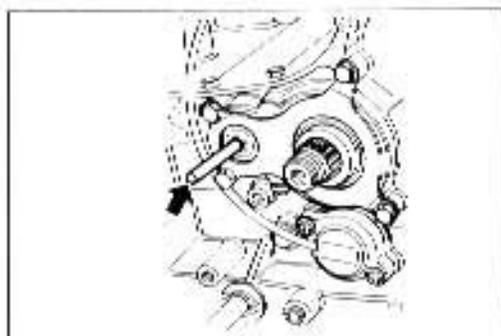

- Degrease the tapered portion of the starter clutch and also the crankshaft. Use nonflammable cleaning solvent to wipe off the oily or greasy matter to make these surfaces completely dry.

**NOTE:**

*Apply a small quantity of THREAD LOCK SUPER "1303"/"1305" to the starter clutch mounting bolt.*

**(For U.S.A. model)**

**99000-32030: THREAD LOCK SUPER "1303"**

**(For the other models)**

**99000-32100: THREAD LOCK SUPER "1305"**

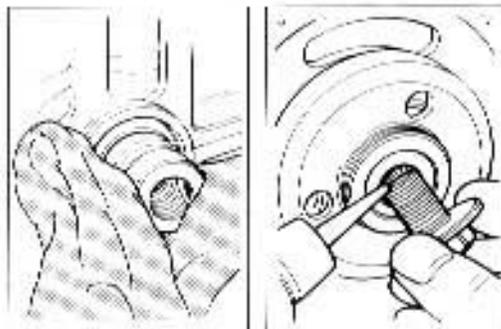

- Tighten the starter clutch mounting bolt to the specified torque by using the special tool and torque wrench.

**Tightening torque: 143 – 157 N·m**

**(14.3 – 15.7 kg·m, 103.5 – 113.5 lb-ft)**

**09920-34810: Starter clutch holder**

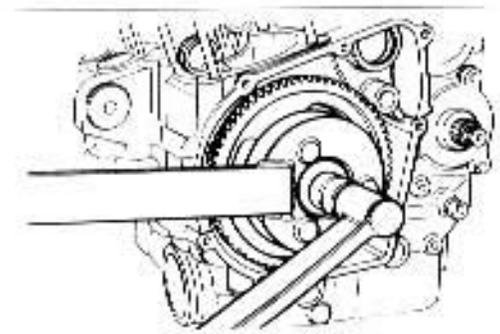

- Install the starter idle gear and its shaft.
- Coat SUZUKI BOND NO. 1207B lightly to the mating surfaces between upper and lower crankcases as shown in the Fig.

**(For U.S.A. model)**

**99104-31140: SUZUKI BOND NO. 1207B**

**(For the other models)**

**99000-31140: SUZUKI BOND NO. 1207B**

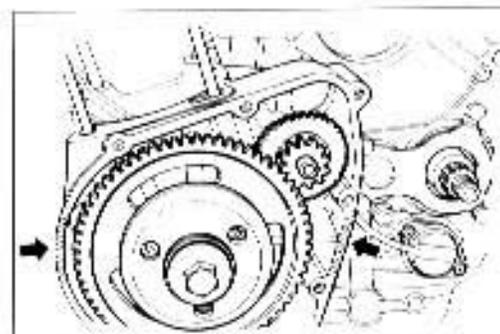

- Install the dowel pin, new gasket and starter clutch cover.
- Tighten the cover bolts securely.

**NOTE:**

*Fit the gasket to the starter clutch cover bolt (A), correctly as shown in the Fig.*

**CAUTION:**

**Use a new gasket to prevent oil leakage.**

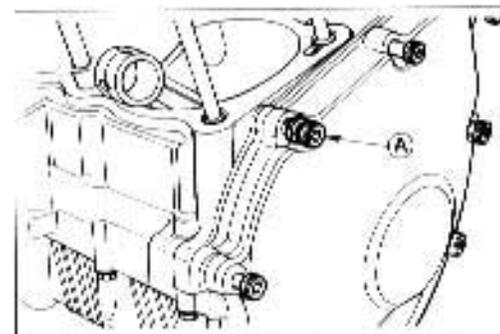

- Install the generator with three bolts.

**Tightening torque: 21 – 29 N·m**

**(2.1 – 2.9 kg·m, 15.0 – 21.0 lb-ft)**

**NOTE:**

*Apply SUZUKI SUPER GREASE "A" to the generator O-ring.*

**(For U.S.A. model)**

**99000-25030: SUZUKI SUPER GREASE "A"**

**(For the other models)**

**99000-25010: SUZUKI SUPER GREASE "A"**

- Install the starter motor with two bolts.

**NOTE:**

*Apply SUZUKI SUPER GREASE "A" to the starter motor O-ring.  
Apply a small quantity of THREAD LOCK "1342" to the bolts.*

**99000-32050: THREAD LOCK "1342"**

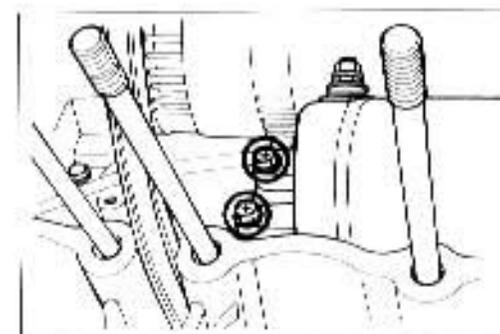
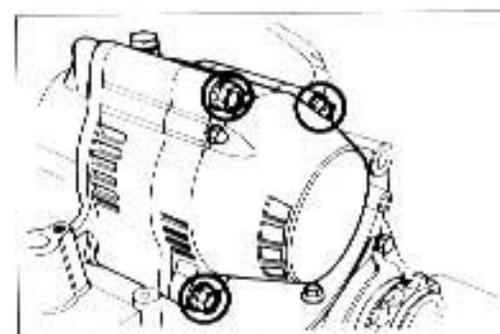

- Install the piston rings in the order of oil ring, 2nd ring and top ring.

**NOTE:**

*Top ring and 2nd ring differ in the shape of the ring face.*

- Top and 2nd ring have a letter "N" marked on the side. Be sure to bring the marked side to the top when fitting them to the piston.

- The first member to go into the oil ring groove is a spacer (1). After placing the spacer, fit the two side rails (2). Side designations, top and bottom, are not applied to the spacer and side rails: you can position each either way.

- Position the gaps of the three rings as shown. Before inserting each piston into the cylinder, check that the gaps are so located.

**CYLINDER STUD BOLT LOCATION**

Item No.	Color	Length
① ③	Black	168 mm (6.6 in)
⑥ ⑧	Silver	157 mm (6.2 in)
② ④ ⑤ ⑦	Silver	164 mm (6.5 in)
⑨ ⑩ ⑪ ⑫	Black	164 mm (6.5 in)

**NOTE:**

*When reinstalling the cylinder stud bolt (7), apply SUZUKI BOND NO. 1207B lightly to its thread.*

**Tightening torque: 13 – 16 N·m**

**(1.3 – 1.6 kg·m, 9.5 – 11.5 lb-ft)**

(For U.S.A. model)

**99104-31140: SUZUKI BOND NO. 1207B**

(For the other models)

**99000-31140: SUZUKI BOND NO. 1207B**

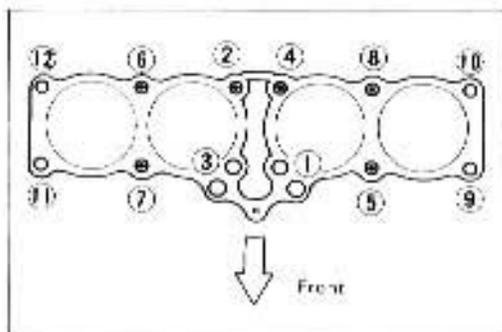
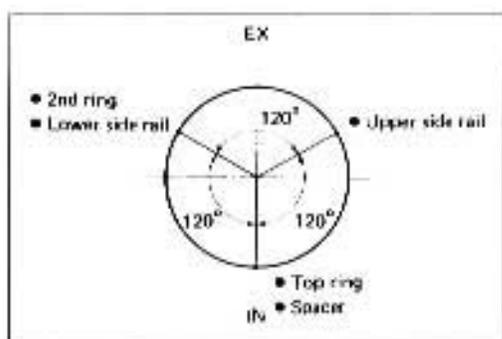
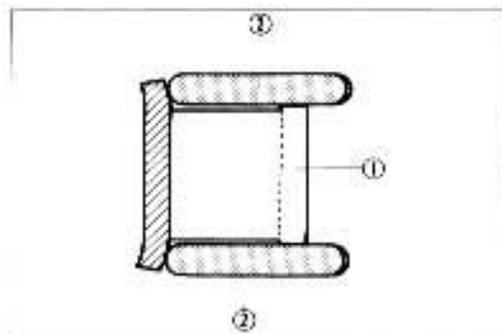
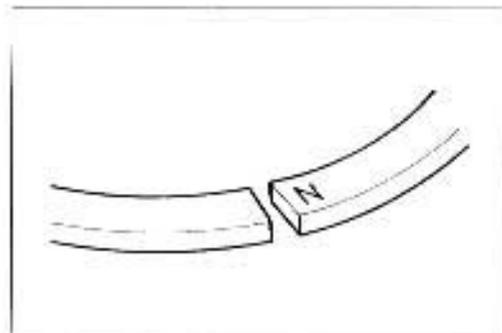
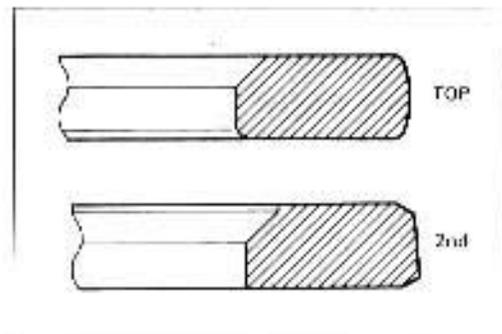

**NOTE:**

Check for clogging the oil jets (Ⓒ) fitted on the crankcase.

**NOTE:**

When fitting the piston, turn the triangle mark on the piston head to exhaust side.

- Be sure to install the pistons in the cylinder from which they were removed in disassembly, refer to the letter mark, "1" through "4", scribed on the piston.
- Have each piston pin oiled lightly before installing it.
- Place a cloth beneath the piston, and install the circlips.

**NOTE:**

Be sure to use new circlips.

- Before putting on the cylinder block, oil the big and small ends of each conrod and also the sliding surface of each piston.
- Place the dowel pins and new cylinder gasket on the crankcase.

**NOTE:**

Be sure to identify the top surface by "UP" mark (Ⓛ) on the cylinder gasket as shown in the Fig.

- Install piston ring holders in the indicated manner. Some light resistance must be overcome to lower the cylinder block.
- With No.2 and No. 3 pistons in place, install No. 1 and No. 4 pistons, and insert them into the cylinder.

**09916-74521: Holder body**

**09916-74540: Band**

**NOTE:**

- \* Do not overtighten the special tool bands or the pistons entry into the cylinders will be difficult.

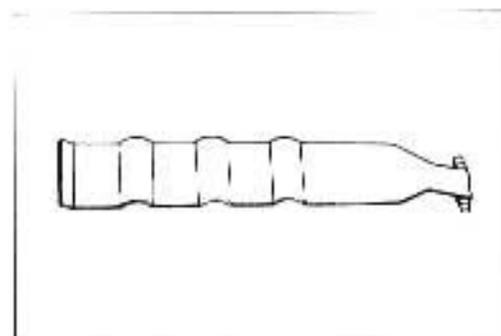
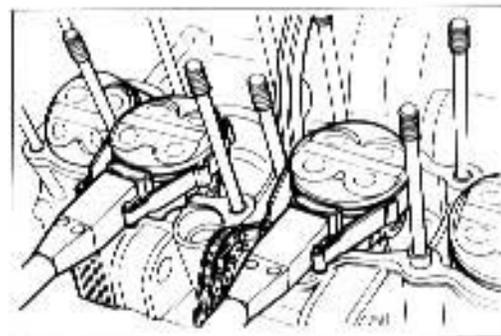
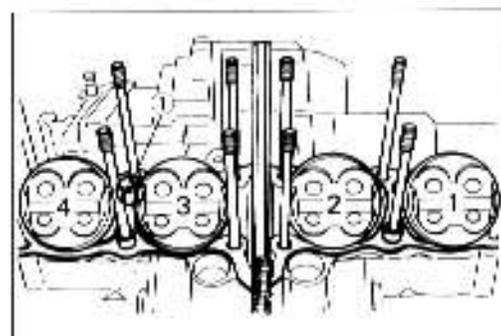
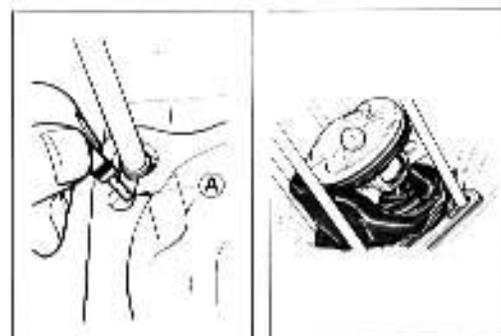

- Tighten the cylinder nut (A) to the specified torque.

**Tightening torque: 7 - 11 N·m**

**(0.7 - 1.1 kg·m, 5.0 - 8.0 lb·ft)**

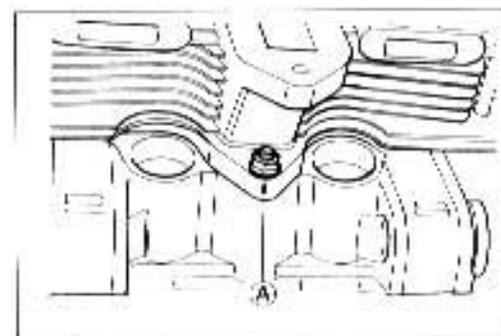

- Place the six O-rings and two dowel pins on the cylinder.

**CAUTION:**

Replace the O-rings with new ones to prevent oil leakage.

- Be sure to replace the cylinder head gasket with a new one to prevent gas leakage.

**NOTE:**

Be sure to identify the top surface by "UP" mark (1) on the cylinder head gasket as shown in the Fig.

- Fit the new O-rings onto the oil pipes and apply SUZUKI SUPER GREASE "A" to the O-rings.
- Install the right and left oil pipes.

(For U.S.A. model)

**99000-25030: SUZUKI SUPER GREASE "A"**

(For the other models)

**99000-25010: SUZUKI SUPER GREASE "A"**

**CAUTION:**

Replace the O-rings (1) with new ones to prevent oil leakage.

- Place the cylinder head on the cylinder block.
- Place the cylinder head plate (1) on the cylinder head, as shown in the illustration.
- Cylinder head nuts and washers must be fitted in the correct positions, as shown in the illustration.
  - (A) Copper washer with cap nut (4 pcs)
  - (B) Steel washer with normal nut (4 pcs)
  - (C) Normal nut (4 pcs)

- Tighten the twelve 10-mm nuts to the specified torque with a torque wrench sequentially in the ascending order of numbers.

**Tightening torque: 35 - 40 N·m**

**[3.5 - 4.0 kg·m, 25.5 - 29.0 lb-ft]**

- After firmly tightening the twelve 10-mm nuts, install one 6-mm bolt (A) and tighten it to the specified torque.

**Tightening torque: 8 - 12 N·m**

**[0.8 - 1.2 kg·m, 6.0 - 8.5 lb-ft]**

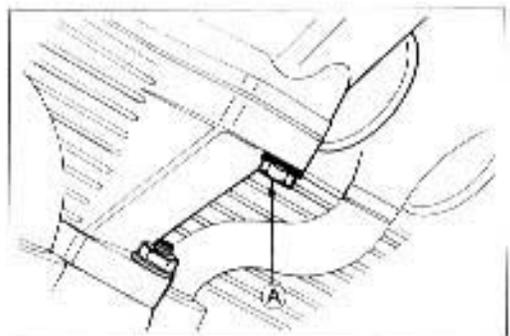
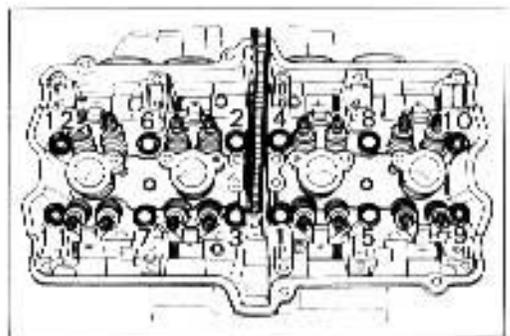
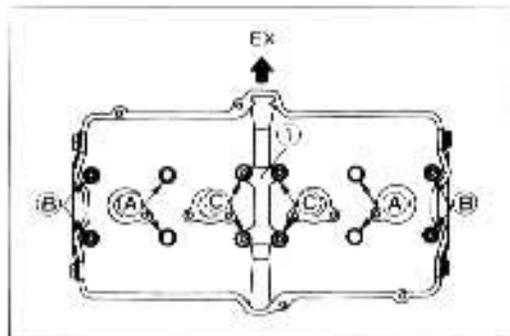
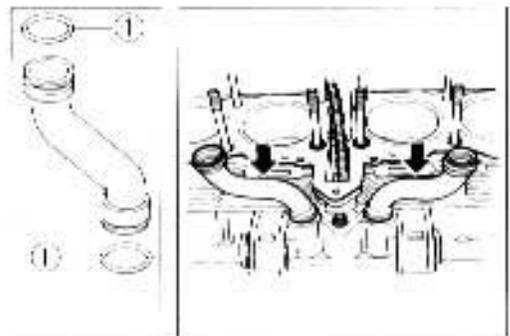
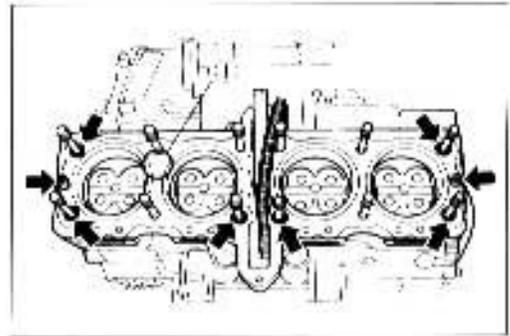



- Place the cam chain guide (1) properly.

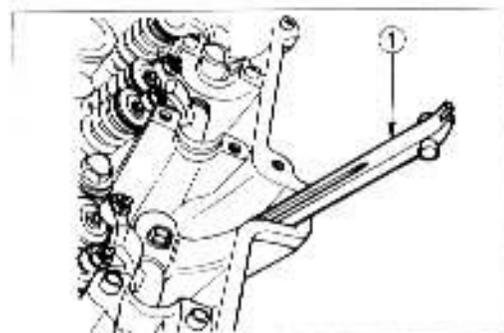

- While holding down the cam chain, rotate the crankshaft in normal direction to bring the "T" mark on the rotor to the center of pick up coil.

**CAUTION:**

To turn over crankshaft, torque nut with a 19 mm wrench. Never try to rotate crankshaft by putting a 6 mm T-type wrench over the bolt.

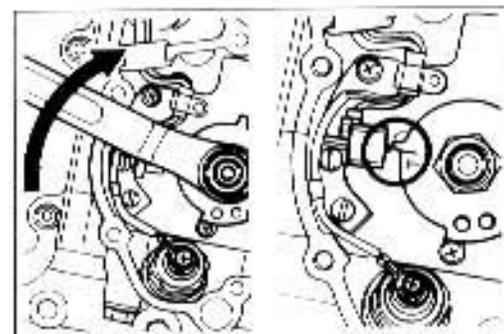

**NOTE**

Just before placing the camshaft on the cylinder head, apply SUZUKI MOLY PASTE to its journals, fully coating each journal (2) with the paste taking care not to leave any dry spot. Apply engine oil to the camshaft journal holders.

99000-25140; SUZUKI MOLY PASTE

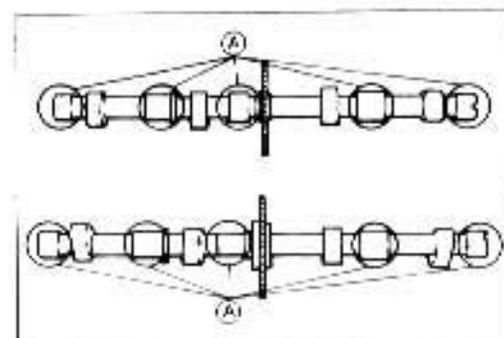

- The exhaust camshaft can be distinguished from that of the intake by the embossed letters "EX" (for exhaust) as against letters "IN" (for intake). Similarly, the right end can be distinguished by the notch (1) at the right end.

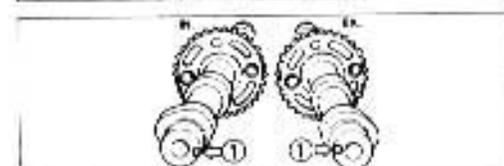
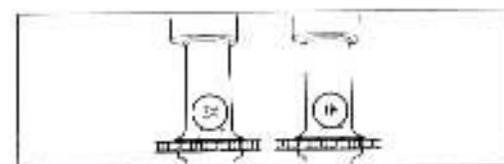

- With "T" mark accurately lined up with the timing mark, hold the camshaft steady and lightly pull up the chain to remove the slack between the crank sprocket and exhaust sprocket.
- The exhaust sprocket bears an arrow marked "1" indicated as (1). Turn over the exhaust camshaft so that the arrow points flush with the gasketed surface of the cylinder head. Engage the cam chain with this sprocket.

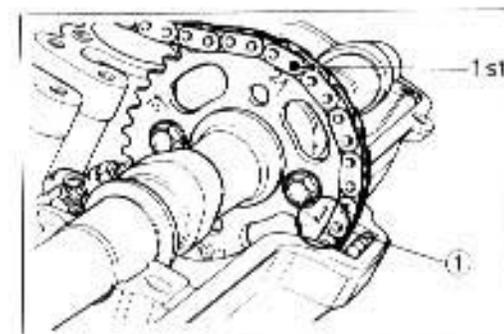

- The other arrow marked "2" is now pointing straight upward. Count the chain roller pins toward the intake camshaft, starting from the roller pin directly above this arrow marked "2" and ending with the 22nd roller pin. Engage the cam chain with intake sprocket, locating the 22nd pin at the above the arrow marked "3" on the intake sprocket.

**NOTE:**

*The cam chain is now riding on all three sprockets. Be careful not to disturb the crankshaft until the ten camshaft journal holders, cam chain idler and cam chain tensioner are secured.*

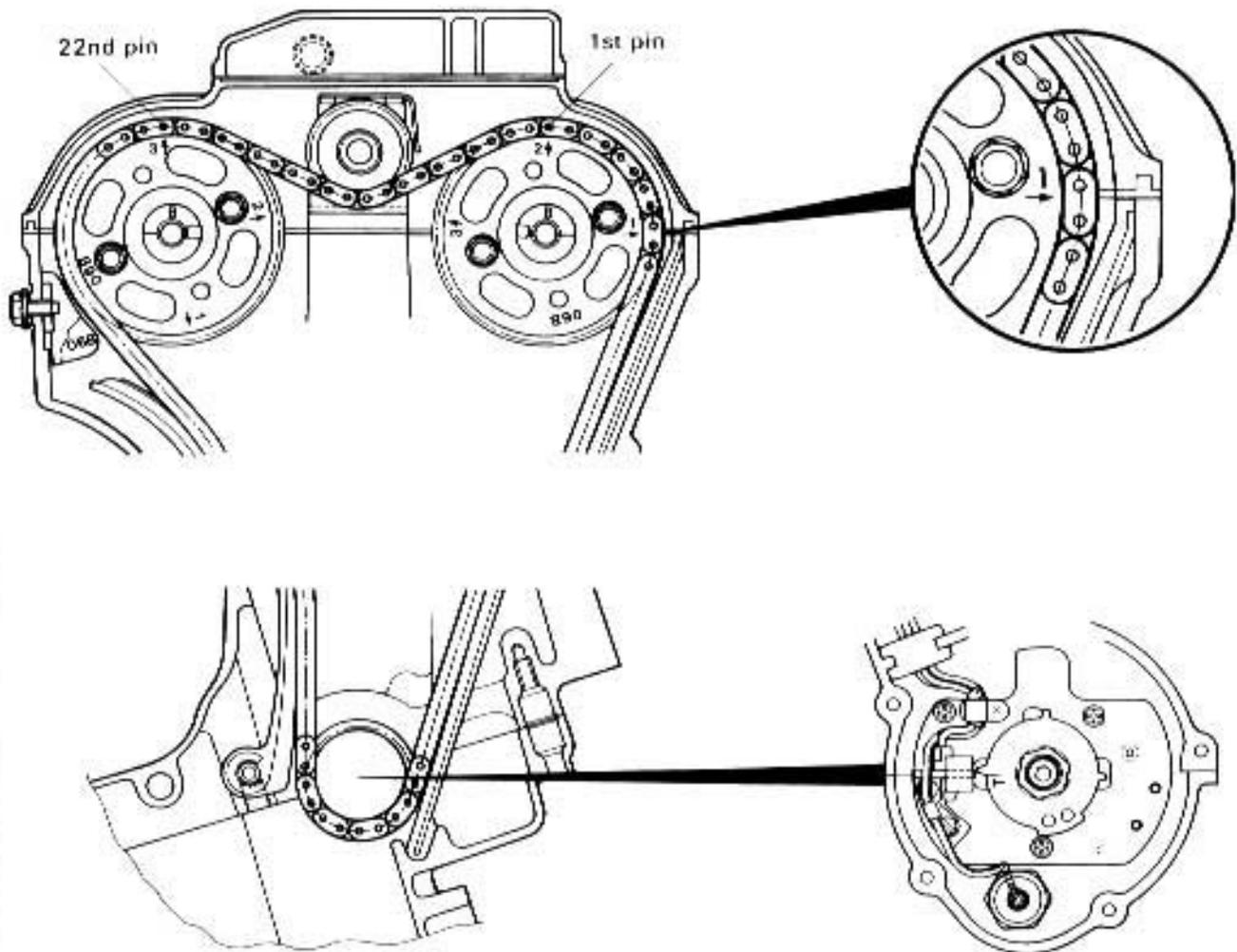
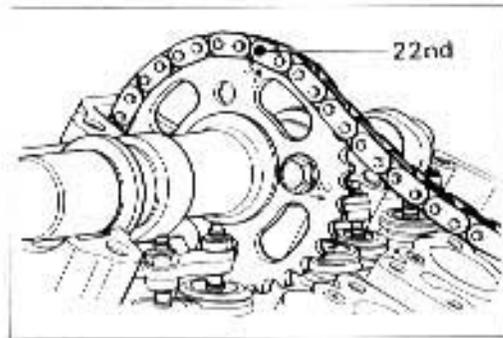

- Each camshaft journal holder is identified with a cast-on letter. Install the dowel pins to each camshaft journal holder.
- Secure the ten camshaft journal holders evenly by tightening the camshaft journal holder bolts sequentially. Try to equalize the pressure by moving the wrench diagonally from one bolt to another and from one camshaft journal holder to another, to secure shafts evenly.

**NOTE:**

*Damage to head or camshaft journal holder thrust surfaces may result if the camshaft journal holders are not drawn down evenly.*

- Tighten the camshaft journal holder bolts to the specified torque.

**Tightening torque: 8 – 12 N.m**

**(0.8 – 1.2 kg-m, 6.0 – 8.5 lb-ft)**

**CAUTION:**

The camshaft journal holder bolts are made of a special material and much superior in strength, compared with other types of high strength bolts.

Take special care not to use other types of bolts instead of these special bolts. To identify these bolts, each of them has a figure "9" on its head.

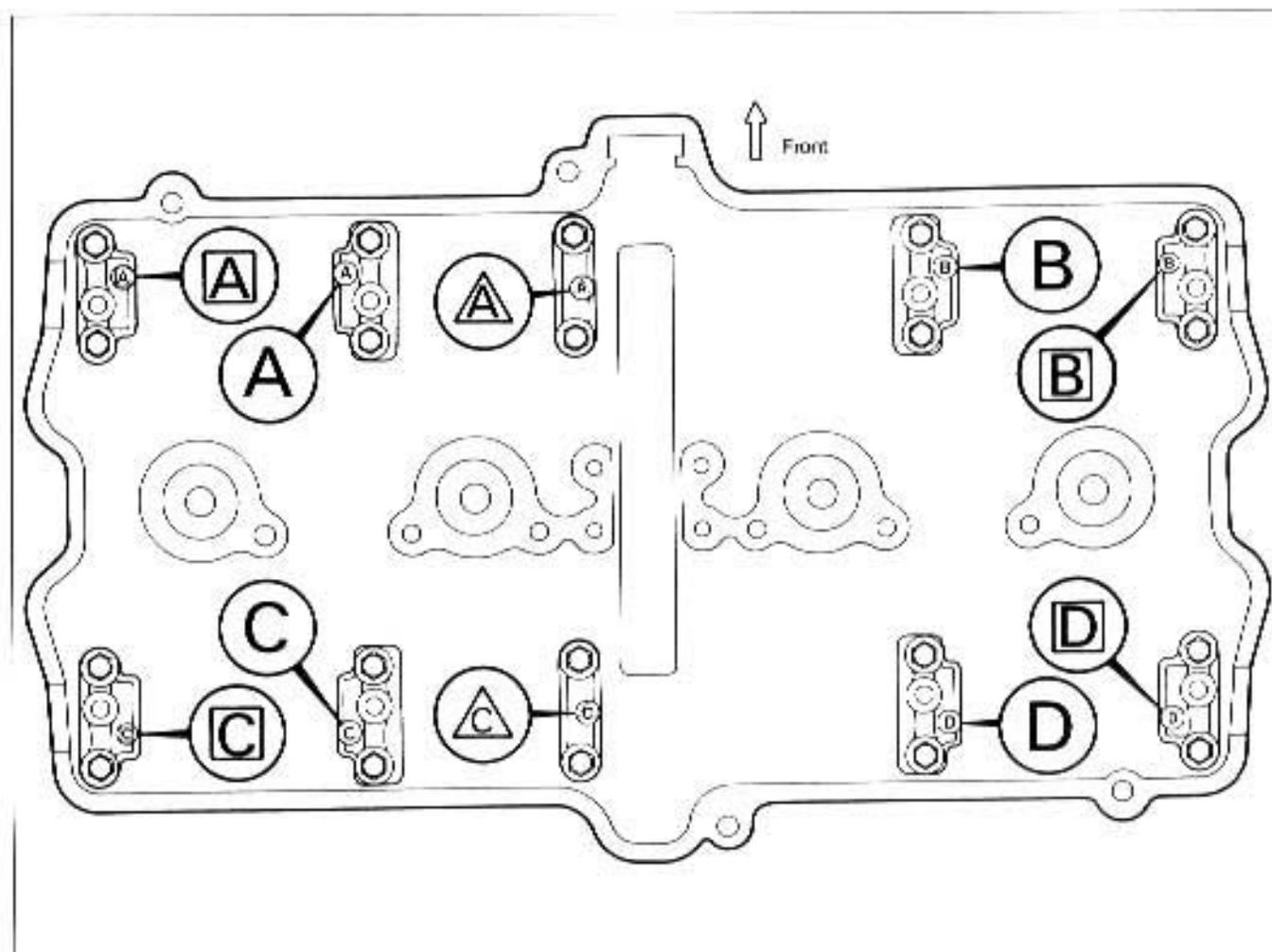
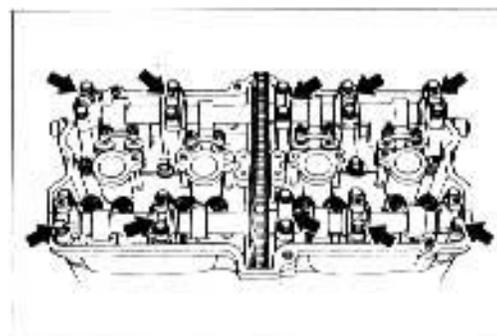

**NOTE:**

Be sure to face the arrow mark on the cam chain idler to the front.

- Tighten the four bolts to the specified torque.

**Tightening torque: 8 – 12 N·m**  
(0.8 – 1.2 kg·m, 6.0 – 8.5 lb-ft)

- Pour about 50 ml of engine oil in each oil pocket in the head.

- After removing the spring holder bolt (1) and spring, unlock the ratchet mechanism (2) and push in the push rod (3) all the way.

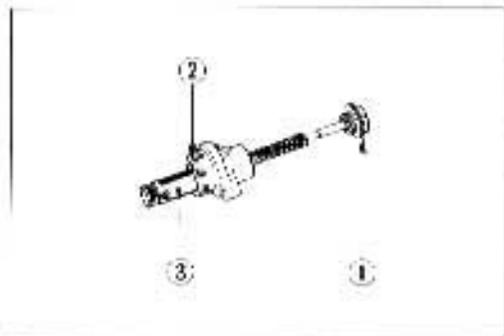
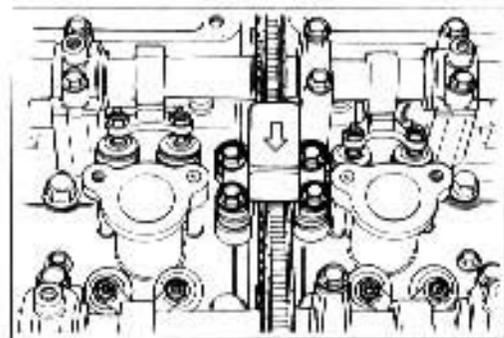

- Install a new gasket and the cam chain tensioner to the cylinder block with two bolts and tighten them to the specified torque.

**Tightening torque: 6 – 8 N·m**  
(0.6 – 0.8 kg·m, 4.5 – 6.0 lb-ft)

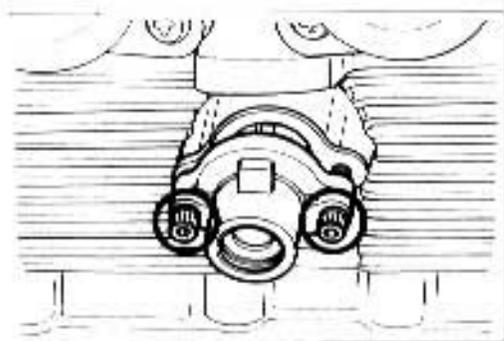

- Insert the spring into the cam chain tensioner and tighten the spring holder bolt (1) to the specified torque.

**Tightening torque: 30 – 45 N·m**  
(3.0 – 4.5 kg·m, 21.5 – 32.5 lb-ft)

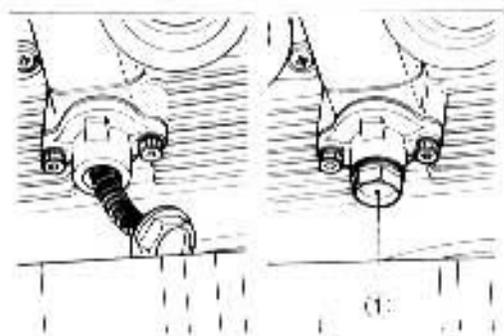
**CAUTION:**

After installing the cam chain tensioner, check to be sure that the tensioner works properly by checking the slack of the cam chain.

**NOTE:**

Turn the crankshaft and check that all the moving parts such as cam follower, camshaft, work properly.

**CAUTION:**

Be sure to check and adjust the valve clearance. (Refer to page 2-5.)

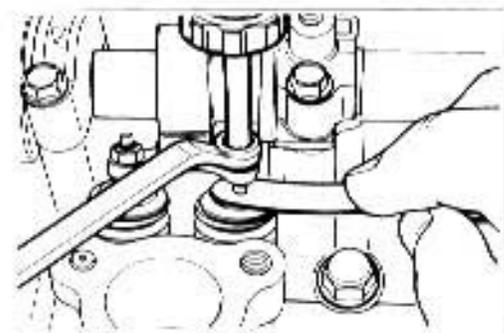

- Coat SUZUKI BOND NO. 1207B lightly to the mating surfaces between upper and lower crankcases as shown in the Fig.

(For U.S.A. model)

99104-31140: SUZUKI BOND NO. 1207B

(For the other models)

99000-31140: SUZUKI BOND NO. 1207B

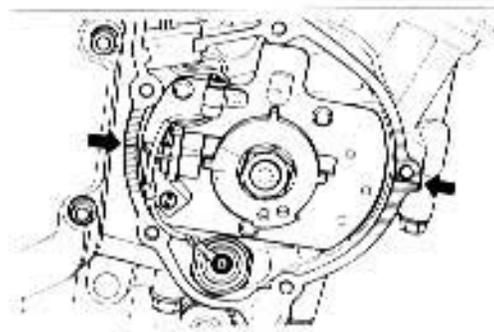

- Install a new gasket and the signal generator cover with five bolts.

**NOTE:**

Fit the gasket to the signal generator cover bolt (A) correctly as shown in the Fig.

**CAUTION:**

Use a new gasket to prevent oil leakage.

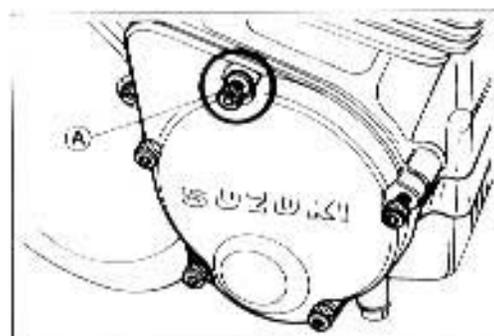

- Before installing the cylinder head cover gaskets on the cylinder head cover, apply SUZUKI BOND NO. 1207B to the grooves of the head cover.
- Apply SUZUKI BOND NO. 1207B to the four cam end caps of the gasket as shown in the Fig.

(For U.S.A. model)

99104-31140: SUZUKI BOND NO. 1207B

(For the other models)

99000-31140: SUZUKI BOND NO. 1207B

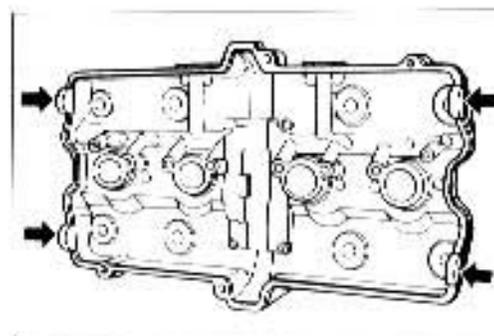

- Place the cylinder head cover on the cylinder head.
- Fit up the four gaskets to the head cover's union bolts.
- Seat the eight gaskets to each exact position.

**CAUTION:**

Replace the gaskets with new ones to prevent oil leakage.

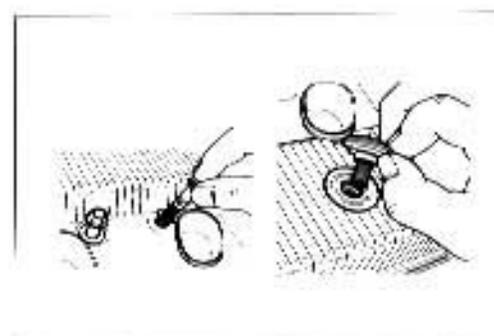

- After tightening the head cover union bolts (1) to the specified torque, tighten the head cover bolts (2) to the specified torque.

**Tightening torque**

Head cover union bolt (1): 15 - 17 N·m

(1.5 - 1.7 kg·m, 11.0 - 12.5 lb-ft)

Head cover bolt (2): 13 - 15 N·m

(1.3 - 1.5 kg·m, 9.5 - 11.0 lb-ft)

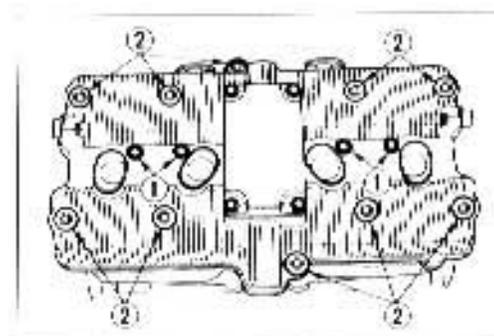

- Attach the right and left oil hoses and tighten the bolts to the specified torque.

**Tightening torque: 8 - 12 N·m**  
(0.8 - 1.2 kg-m, 6.0 - 8.5 lb-ft)

**CAUTION:**

Replace the O-rings (A) and (B) with new ones to prevent oil leakage.

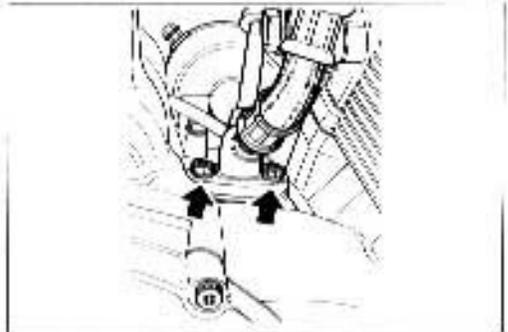
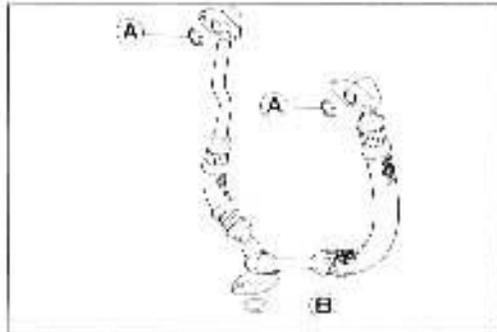
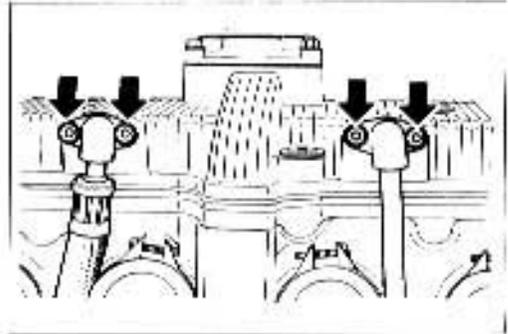

**NOTE:**

When replacing the intake pipes, identify the four different intake pipes according to each I.D. code.

{13110-40C0 for No. 1}

{13120-40C0 for No. 2}

{13130-40C0 for No. 3}

{13140-40C0 for No. 4}

**CAUTION:**

Use a new O-ring to prevent sucking air from the joint.

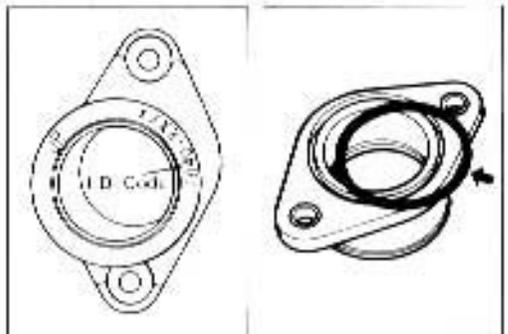

# FUEL AND LUBRICATION SYSTEM

## CONTENTS

<b>FUEL TANK, FUEL COCK AND FUEL LEVEL INDICATOR SWITCH...</b>	<b>4- 1</b>
<b>FUEL TANK REMOVAL</b> .....	<b>4- 1</b>
<b>FUEL COCK REMOVAL</b> .....	<b>4- 1</b>
<b>FUEL LEVEL INDICATOR SWITCH REMOVAL</b> .....	<b>4- 1</b>
<b>INSPECTION AND CLEANING</b> .....	<b>4- 1</b>
<b>FUNDAMENTAL OF FUEL COCK</b> .....	<b>4- 2</b>
<b>CARBURETOR</b> .....	<b>4- 3</b>
<b>CONSTRUCTION</b> .....	<b>4- 3</b>
<b>SPECIFICATIONS</b> .....	<b>4- 4</b>
<b>I.D. NO. LOCATION</b> .....	<b>4- 5</b>
<b>DIAPHRAGM AND PISTON OPERATION</b> .....	<b>4- 6</b>
<b>SLOW SYSTEM</b> .....	<b>4- 7</b>
<b>MAIN SYSTEM</b> .....	<b>4- 8</b>
<b>STARTER SYSTEM</b> .....	<b>4- 9</b>
<b>FLOAT SYSTEM</b> .....	<b>4- 9</b>
<b>FUEL SYSTEM</b> .....	<b>4-10</b>
<b>DISASSEMBLY</b> .....	<b>4-11</b>
<b>INSPECTION AND ADJUSTMENT</b> .....	<b>4-11</b>
<b>REASSEMBLY</b> .....	<b>4-12</b>
<b>BALANCE OF CARBURETORS</b> .....	<b>4-13</b>
<b>LUBRICATION SYSTEM</b> .....	<b>4-17</b>
<b>OIL PRESSURE</b> .....	<b>4-17</b>
<b>OIL FILTER</b> .....	<b>4-18</b>
<b>OIL SUMP FILTER</b> .....	<b>4-18</b>
<b>RELIEF VALVE</b> .....	<b>4-18</b>
<b>ENGINE LUBRICATION SYSTEM CHART</b> .....	<b>4-19</b>
<b>ENGINE LUBRICATION SYSTEM</b> .....	<b>4-20</b>
<b>CYLINDER HEAD COOLING SYSTEM CHART</b> .....	<b>4-21</b>
<b>CYLINDER HEAD COOLING SYSTEM</b> .....	<b>4-22</b>
<b>OIL COOLER</b> .....	<b>4-23</b>

## FUEL TANK, FUEL COCK AND FUEL LEVEL INDICATOR SWITCH

### FUEL TANK REMOVAL

- Remove the seat.
- Remove the middle fairings.
- Remove the fuel tank mounting bolts.
- Turn the fuel cock to "ON" position and remove the fuel cock lever.
- Disconnect the fuel level indicator switch leads.
- Remove the fuel tank after disconnecting all hoses from fuel cock. (Refer to 3-5 page.)

### FUEL COCK REMOVAL

- Remove the fuel cock assembly by removing the two bolts (1).

#### WARNING:

Gasoline is very explosive. Extreme care must be taken. Gaskets must be replaced with new ones to prevent fuel leakage.



### FUEL LEVEL INDICATOR SWITCH

- Remove the fuel level indicator switch assembly. (Refer to page 5-24 for inspection.)

#### WARNING:

Gasoline is very explosive. Extreme care must be taken. Gaskets must be replaced with new ones to prevent fuel leakage.

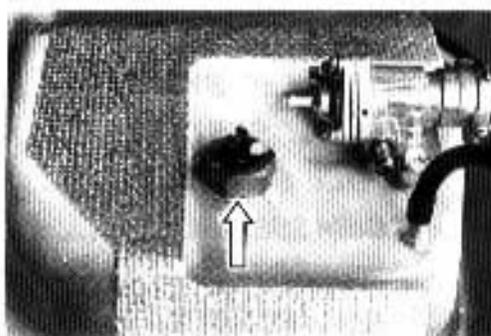

### INSPECTION AND CLEANING

If the fuel strainer is dirty with sediment or rust, fuel will not flow smoothly and loss in engine power may result. Clean the fuel strainer with compressed air.

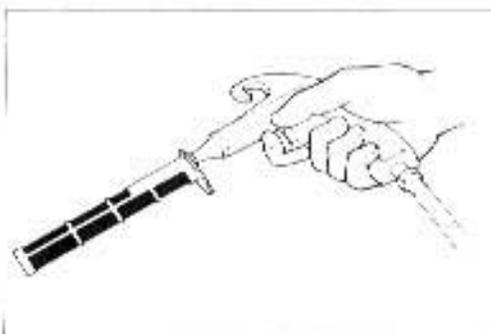



## FUNDAMENTAL OF FUEL COCK

It explains of the construction of diaphragm type fuel cock.

**ON:** Normally used. Functions as an auto fuel cock

**RES:** Reserve fuel is used. Functions as an auto fuel cock

**PRI:** Fuel is directly supplied. Does not function as an auto fuel cock

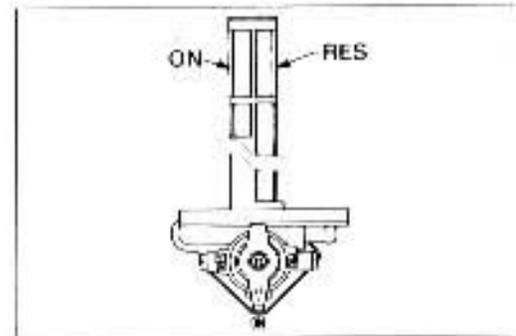

### ENGINE STOP CONDITION

When the engine is not running with the lever in the ON or RES position, the fuel valve (1) is kept in the closed position by applying pressure and utilizing the tension of spring (2) so that no fuel will flow to the carburetors.

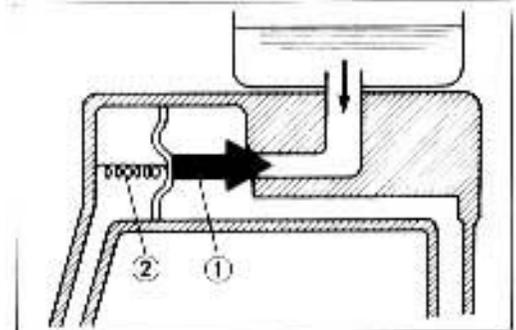

### ENGINE RUNNING CONDITION

When the engine is started, a negative pressure (A) is generated in the diaphragm chamber (3) through the vacuum (negative pressure) pipe (4) which is connected to the carburetor, and builds up a negative pressure (A) which is higher than the tension of spring (2) so that the diaphragm (5) is forced to open the fuel valve (1) and thus allow the fuel to flow to the carburetors (B).

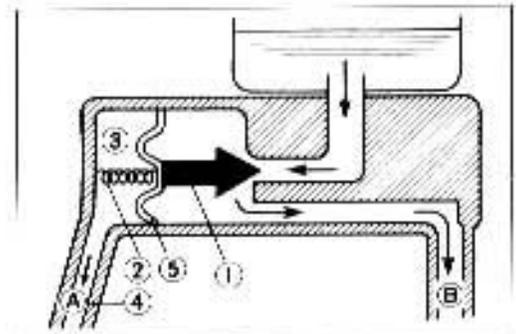

### "PRI" POSITION

When the fuel valve (2) is set at the PRI position, fuel flows to the carburetors directly because that the protrusion located on the lever end pushes back the fuel valve (1) mechanically against the spring tension, whether the engine is running or not, through the RES side fuel filter and fuel valve clearance. The PRI position is used when the carburetor have little or no fuel, for example, when filling the fuel tank for the first time, or when the motorcycle has been left unused for a long time, or when the carburetors have been disassembled and repaired. Shift the lever to the ON position when the engine begins to run smoothly.

# CARBURETOR CONSTRUCTION

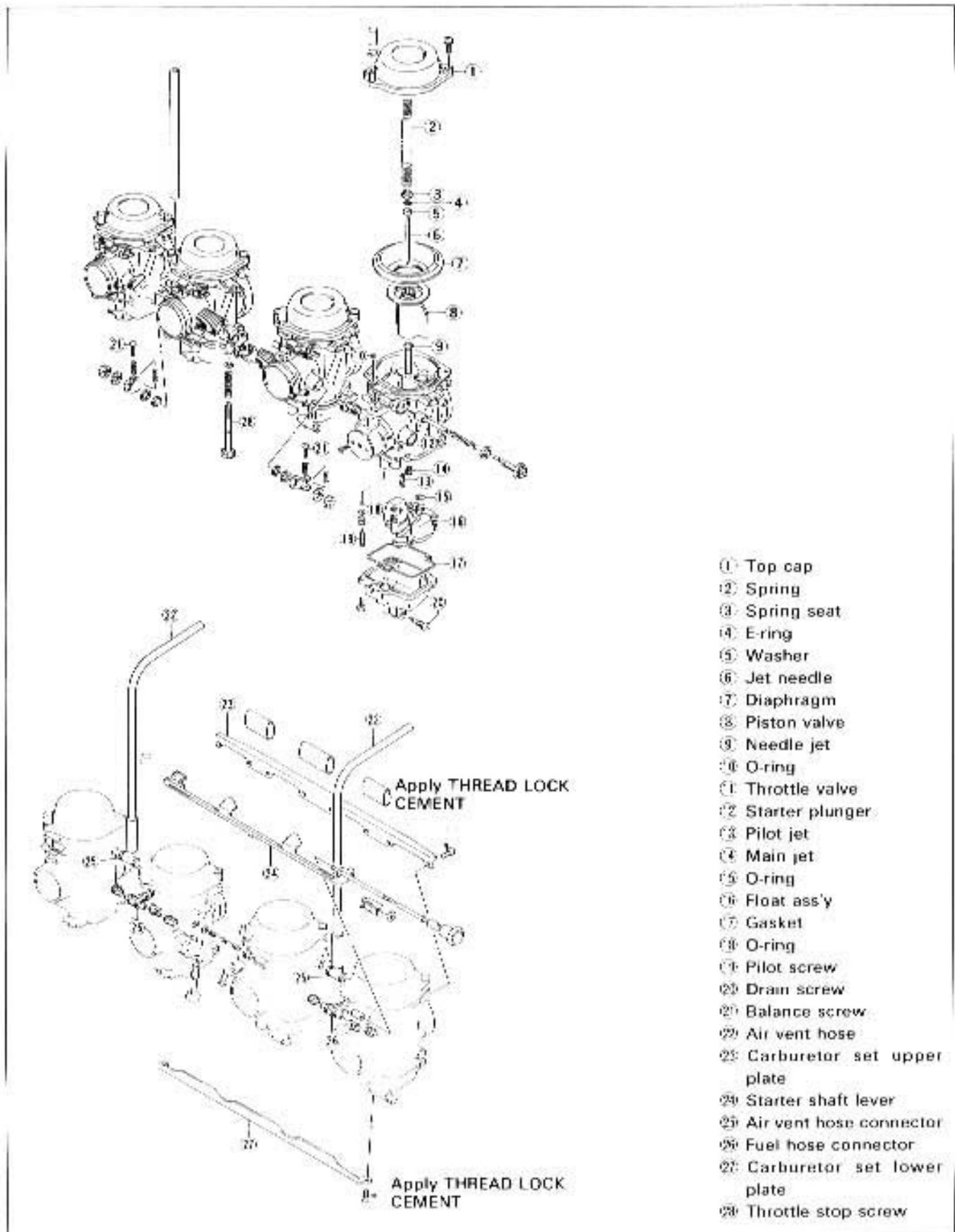

## SPECIFICATIONS

ITEM	SPECIFICATION						
	E-01, 16, 28	E-02, 04, 17, 21, 25, 34, 53	E-24	E-22	E-39	E-15	E-18
Carburetor type	MIKUNI BST36SS	*	←	←	*	←	←
Bore size	36 mm (1.4 in)	*	←	←	*	←	←
I.D.No.	40C00	40C40	40C50	40C60	40C80	40C90	40C30
Idle r/min.	1100 ± 100 r/min	←	←	←	←	←	1100 ±100 50 r/min
Float height	14.6 ± 1.0 mm (0.57 ± 0.04 in)	←	←	←	←	←	←
Main jet (M.J.)	#122.5	←	←	←	←	←	#110
Main air jet (M.A.J.)	1.5 mm	←	←	←	←	←	*
Jet needle (J.N.)	5E56-3rd	5E60-3rd	←	←	←	←	5D44-3rd
Needle jet (N.J.)	0-9	0-8	←	←	←	←	0-9
Pilot jet (P.J.)	#40	←	←	←	←	←	#30
By-pass (B.P.)	0.8 mm	←	←	←	←	←	←
Pilot outlet (P.O.)	0.7 mm	←	←	←	←	←	←
Valve seat (V.S.)	2.3 mm	←	←	←	←	←	←
Starter jet (G.S.)	#45	←	←	←	←	←	#42.5
Pilot screw (P.S.)	PRE-SET (2 turns out)	←	←	PRE-SET (1 5/8 turns out)	←	PRE-SET (2 turns out)	PRE-SET (1 1/2 turns out)
Pilot air jet (P.A.J.)	1.4 mm	←	←	*	←	←	1.35 mm
Throttle cable play	0.5-1.0 mm (0.02-0.04 in)						

E-01 : General  
 E-02 : England  
 E-04 : France  
 E-15 : Finland  
 E-16 : Norway  
 E-17 : Sweden  
 E-18 : Switzerland  
 E-21 : Belgium

E-22 : W.Germany  
 E-24 : Australia  
 E-25 : Netherlands  
 E-28 : Canada  
 E-34 : Italy  
 E-39 : Austria  
 E-53 : Spain

ITEM	SPECIFICATION		
	U.S.A. model (Except for California)	U.S.A. model (California model only)	Switzerland model
Carburetor type	MIKUNI BST36SS	*	+
Bore size	36 mm (1.4 in)	+	*
I.D.No.	40C10	40C20	40C30
Idle r/min.	1200 ± 100 r/min	1100 ± 100 r/min	1100 ± $\frac{100}{50}$ r/min
Float height	14.6 ± 1.0 mm (0.57 ± 0.04 in)	+	*
Main jet (M.J.)	# 122.5	+	#110
Main air jet (M.A.J.)	1.5 mm	*	+
Jet needle (J.N.)	5D42	5D43	5D44 3rd
Needle jet (N.J.)	U-8	+	0-8
Pilot jet (P.J.)	# 30	+	#30
By-pass (B.P.)	0.8 mm	+	+
Pilot outlet (P.O.)	0.7 mm	+	+
Valve seat (V.S.)	2.3 mm	+	+
Starter jet (S.J.)	#45	+	#42.5
Pilot screw (P.S.)	PRE-SET	+	PRE SET (1½ turns out)
Pilot air jet (P.A.J.)	1.35 mm	1.2 mm	1.35 mm
Throttle cable play	0.5 - 1.0 mm (0.02 - 0.04 in)	+	*

### I.D.NO. LOCATION

Each carburetor has I.D. Number (I) printed on the carburetor body according to its specifications.

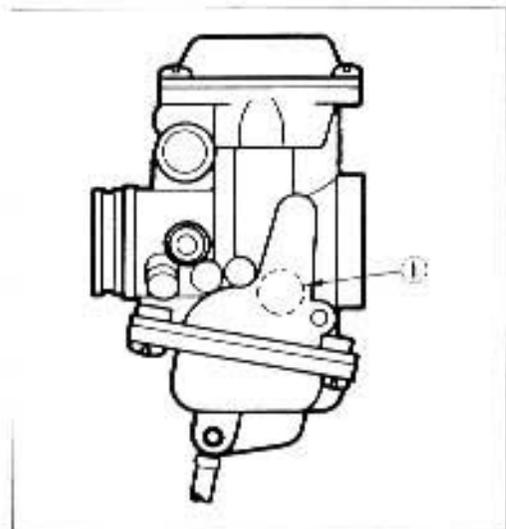

## DIAPHRAGM AND PISTON OPERATION

The carburetor is a variable-venturi type, whose venturi cross section area is increased or decreased automatically by the piston valve (1) which moves according to the negative pressure present on the downstream side of the venturi (A). Negative pressure is admitted into the diaphragm chamber (2) through two orifices (3) provided in the piston valve (1).

Rising negative pressure overcomes the spring (4) force, causing the piston valve (1) to rise to increase the said area and thus prevent the air velocity from increasing. Thus, air velocity in the venturi passage is kept relatively constant for improved fuel atomization and for securing optimum ratio of fuel/air mixture.

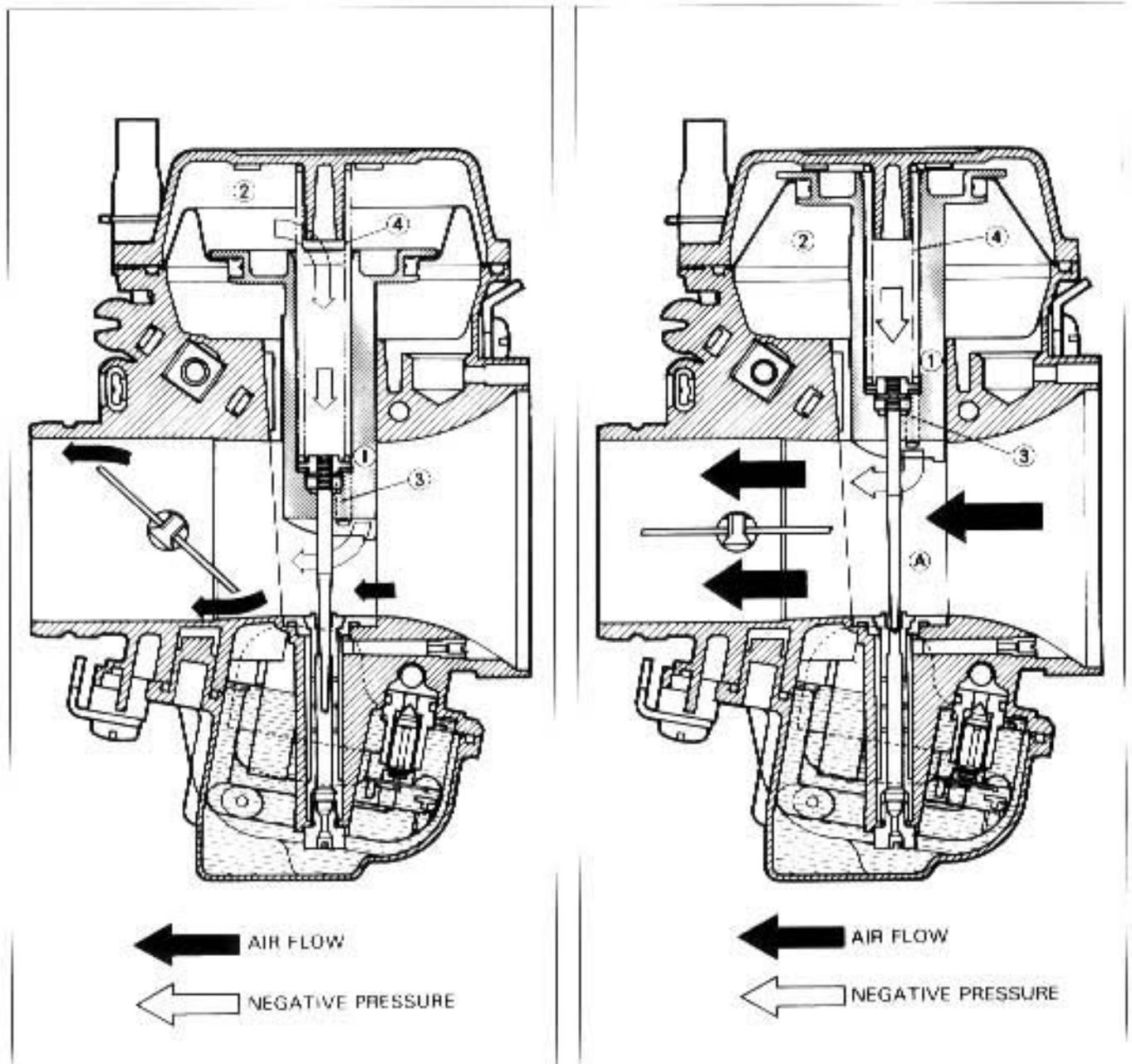

## SLOW SYSTEM

This system supplies fuel during engine operation with throttle valve ① closed or slight opened. The fuel from float chamber ② is metered by pilot jet ③ where it mixes with air coming in through pilot air jet ④. This mixture, rich with fuel, then goes up through pilot passage to pilot screw ⑤. A part of the mixture is discharged into the main bore out of bypass ports ⑥. The remainder is then metered by pilot screw ⑤ and sprayed out into the main bore through pilot outlet ⑦.

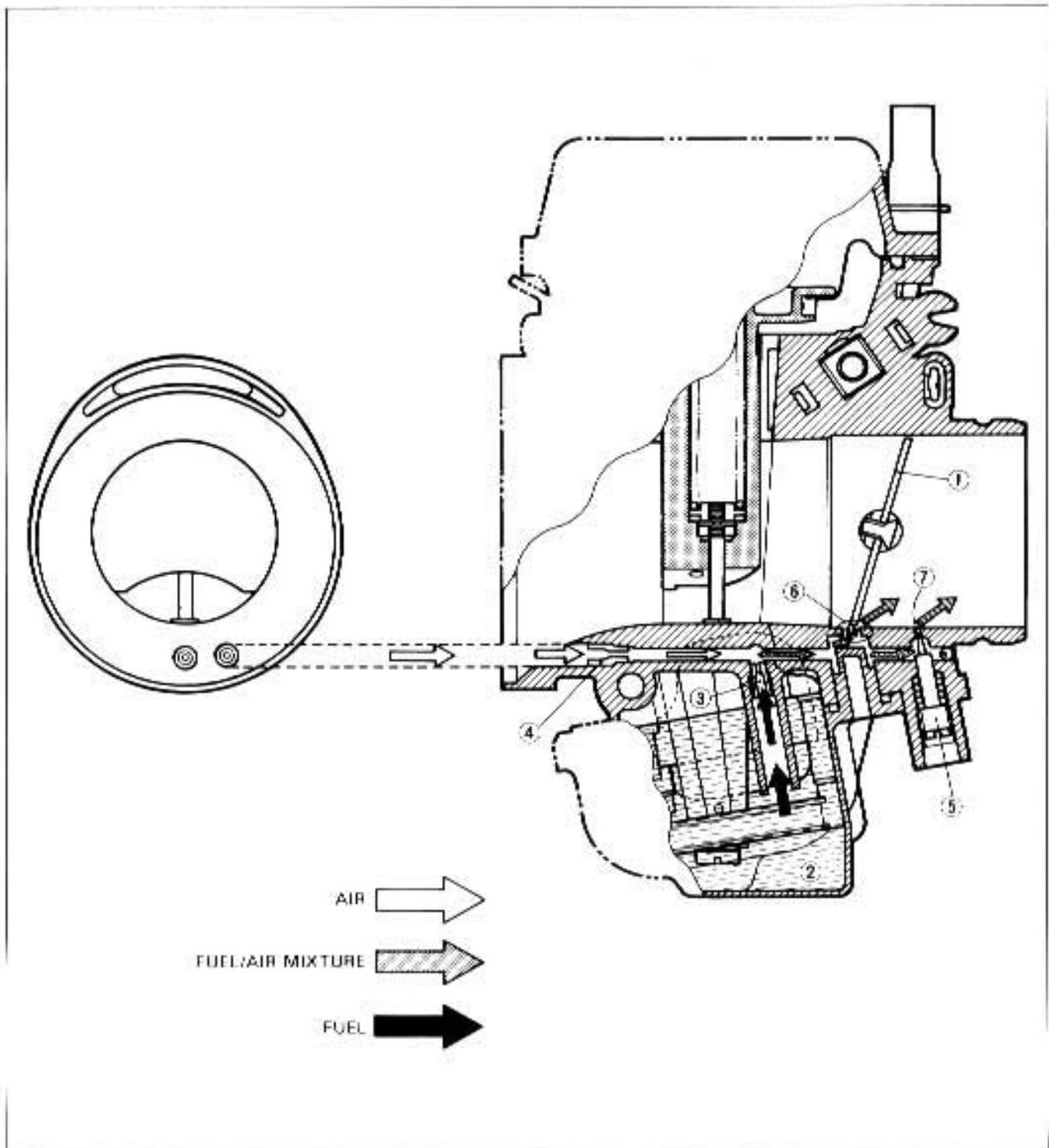

## MAIN SYSTEM

As throttle valve ① is opened, engine speed rises, and this increases negative pressure in the venturi ⑧. Consequently the piston valve ② moves upward.

Meanwhile, the fuel in float chamber ③ is metered by main jet ④, and the metered fuel enters needle jet ⑤, in which it mixes with the air admitted through main air jet ⑥ to form an emulsion.

The emulsified fuel then passes through the clearance between needle jet ⑤ and jet needle ⑦, and is discharged into the venturi ⑧, in which it meets main air stream being drawn by the engine. Mixture proportioning is accomplished in needle jet ⑤; the clearance through which the emulsified fuel must flow in large or small, depending ultimately on throttle position.

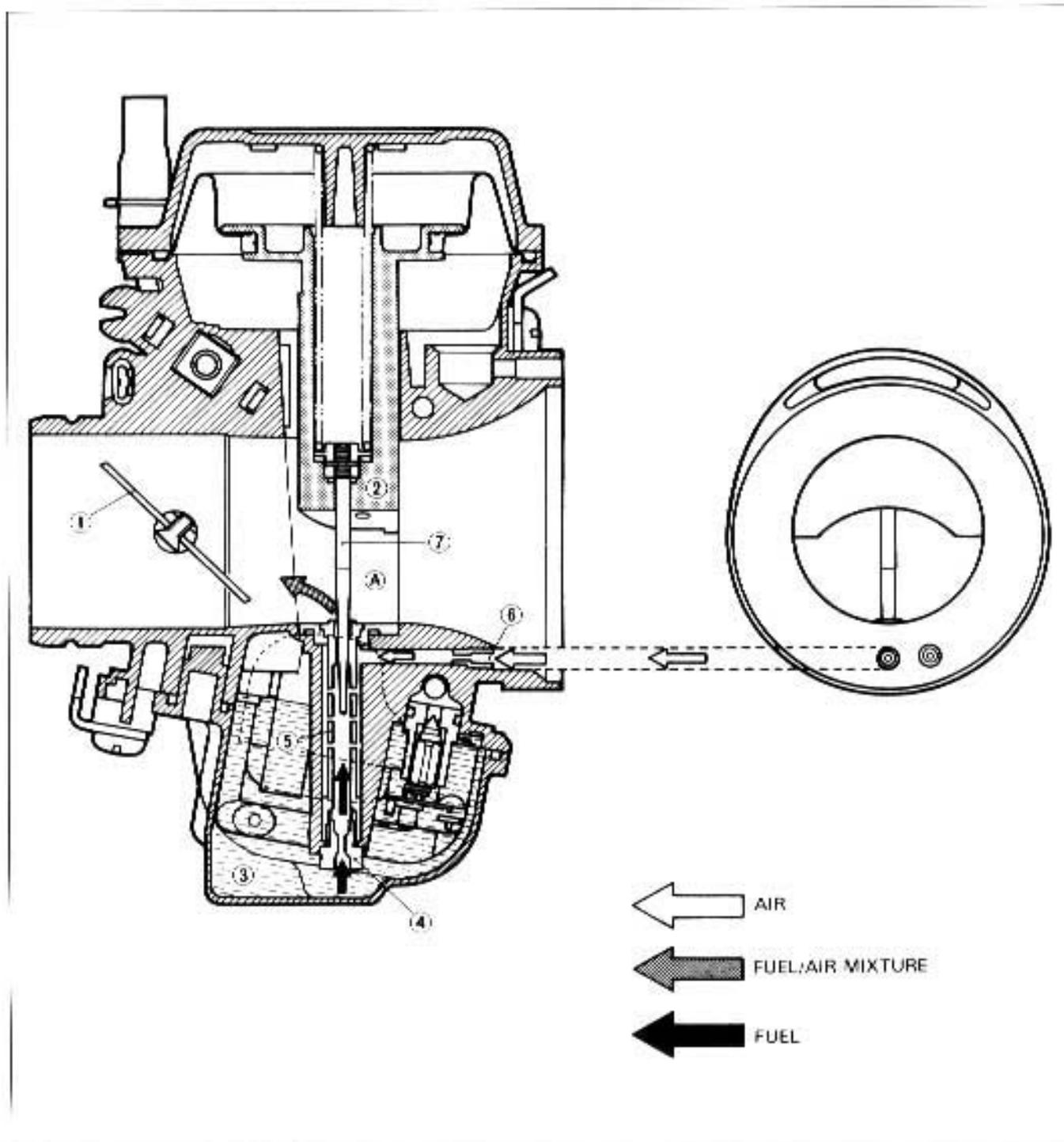

## STARTER SYSTEM

Pulling up the starter shaft (1), fuel is drawn into the starter circuit from the float chamber (2). Starter jet (3) meters this fuel, which then flows into starter pipe (4) and mixes with the air coming from the float chamber (2). The mixture, rich in fuel content, reaches starter plunger (5) and mixes again with the air coming through a passage extending from behind the diaphragm.

The two successive mixings of fuel with air are such that proper fuel/air mixture for starting is produced when the mixture is sprayed out through starter outlet (6) into the main bore.

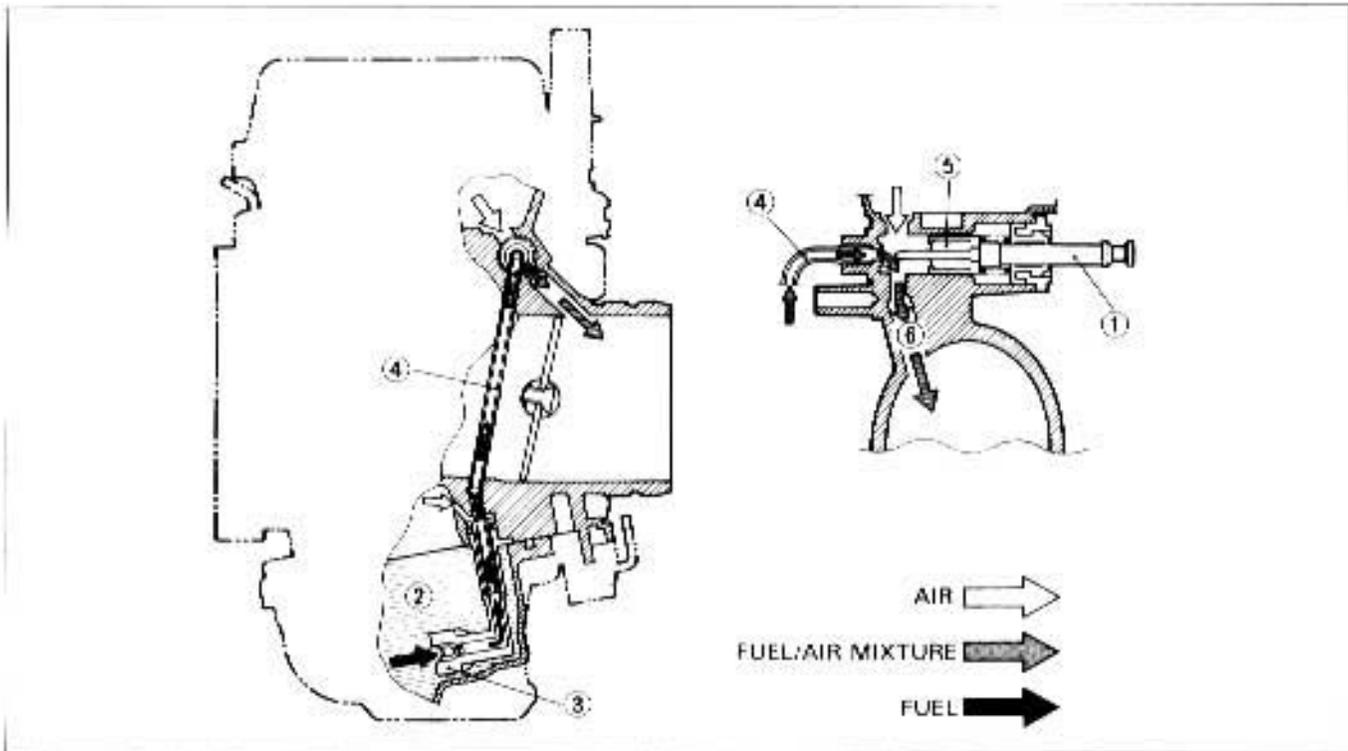

## FLOAT SYSTEM

Floats (1) and needle valve (2) are associated with the same mechanism, so that, as the floats (1) move up and down, the needle valve (2) too moves likewise.

When fuel level is up in float chamber (3), floats (1) are up and needle valve (2) remains pushed up against valve seat. Under this condition, no fuel enters the float chamber (3). As the fuel level falls, floats (1) go down and needle valve (2) unseats itself to admit fuel into the chamber (3).

In this manner, needle valve (2) admits and shuts off fuel alternately to maintain a practically constant fuel level inside the float chamber (3).

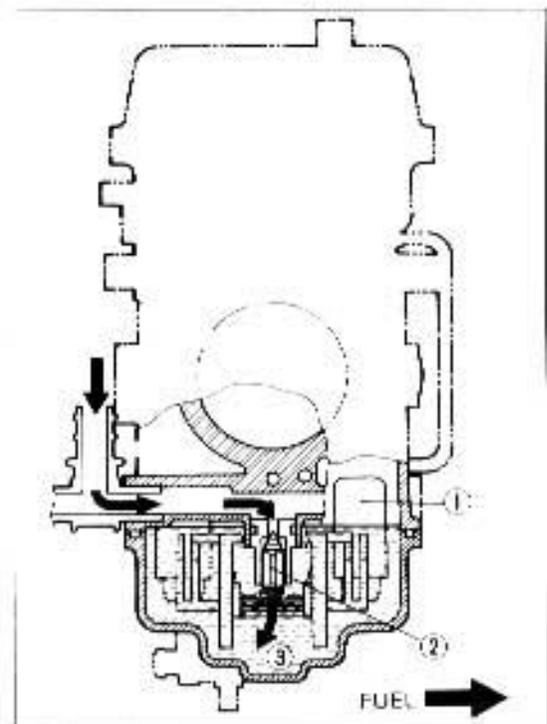



## FUEL SYSTEM

When turning starter motor, negative pressure is generated in the combustion chamber. This negative pressure works on the diaphragm of fuel cock (1) through passage way provided in the carburetor main bore and vacuum hose (2), and diaphragm builds up a negative pressure which is higher than the spring pressure. Fuel valve in the fuel cock (1) is forced to open due to diaphragm operation, and thus allows fuel to flow into carburetor float chamber.

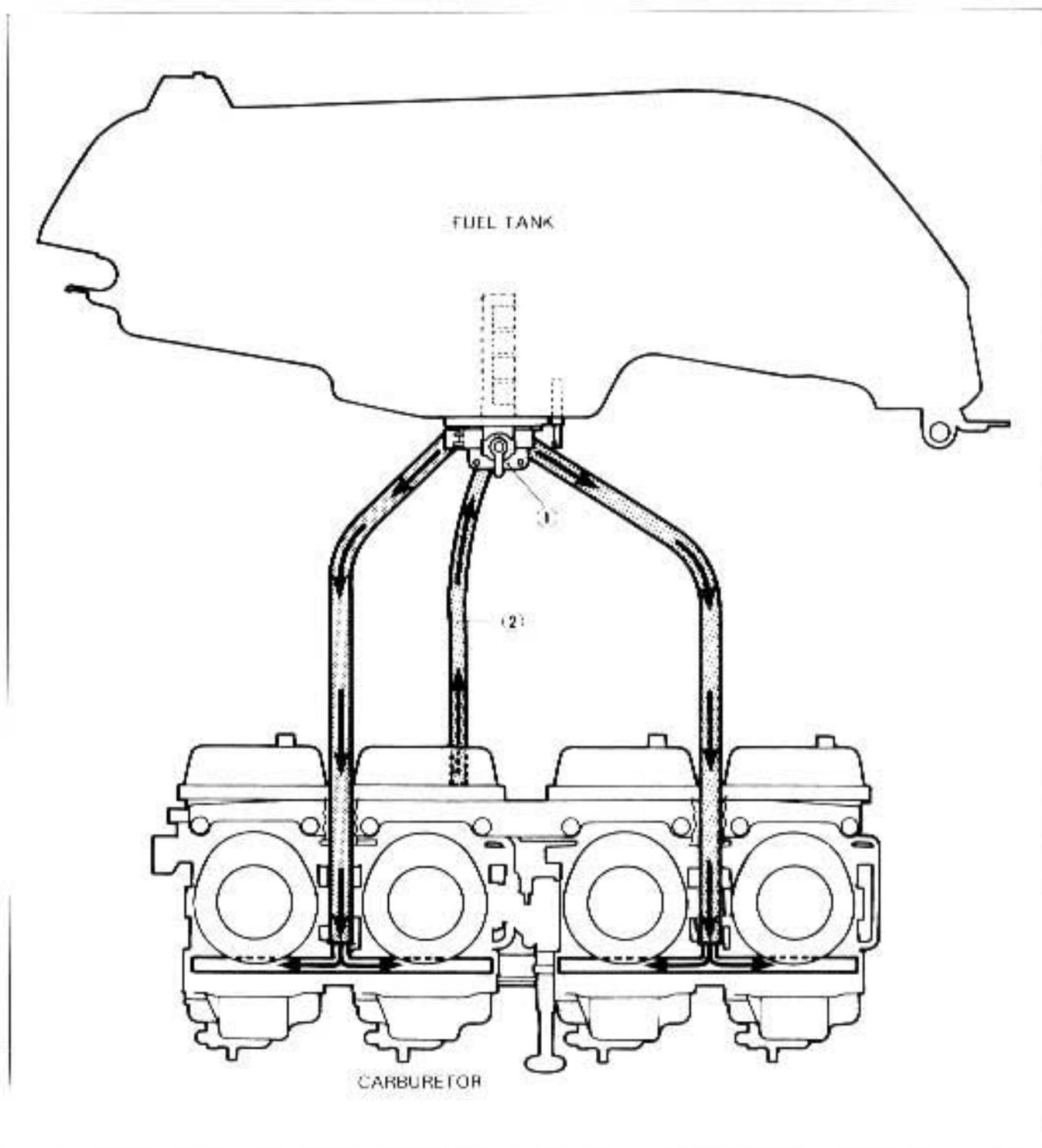

## DISASSEMBLY

For carburetor removal, refer to page 3-5.

Disassemble the carburetor as shown in the illustration on page 4-3.

## INSPECTION AND ADJUSTMENT

### NEEDLE VALVE

If foreign matter is caught the mating surface between the valve seat and needle valve or if they are worn beyond the permissible limits, the gasoline will continue flowing and cause it to overflow. Therefore they should be replaced as a set.

Conversely, if the needle sticks, the gasoline will not flow into the float chamber. If so, clean the float chamber, float parts and fuel passage with gasoline.

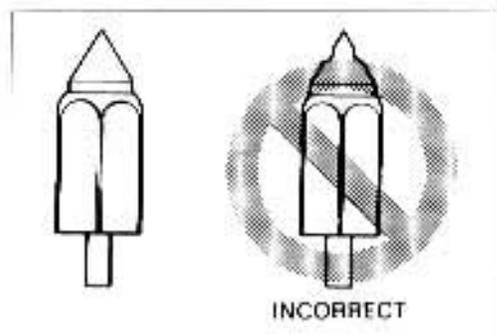

### FLOAT HEIGHT

To check and adjust the float height, carry out the following manner:

- Invert the carburetor body.
- Gradually lower the float and observe the clearance between the float tongue and the end of needle valve. When the tongue just begins to contact the end of needle valve, stop lowering the float and hold it. Then, measure the height (A) from the float chamber mating surface using vernier calipers.

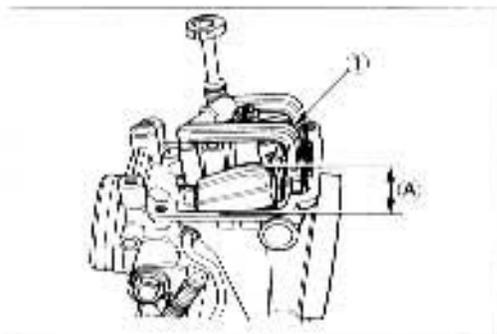

### 09900-20102: Vernier calipers (200 mm)

	Standard
Float height (A)	14.6 + 1.0 mm (0.57 ± 0.04 in)

- Bend the tongue (1) as necessary to bring the height (A) within standard range.

### NOTE:

When measuring the height, be sure not to compress the needle valve spring.

For any damage or clogging, check to see the following items:

- \* Pilot jet
- \* Main jet
- \* Pilot air jet
- \* Main air jet
- \* Needle air jet bleeding holes
- \* Float
- \* Diaphragm
- \* Gasket and O-ring
- \* Throttle valve shaft oil seals
- \* Pilot screw bleeding hole
- \* Pilot outlet and bypass holes

## REASSEMBLY

- When engaging two carburetors or two pairs of carburetors, position the throttle valve control lever (1) correctly.

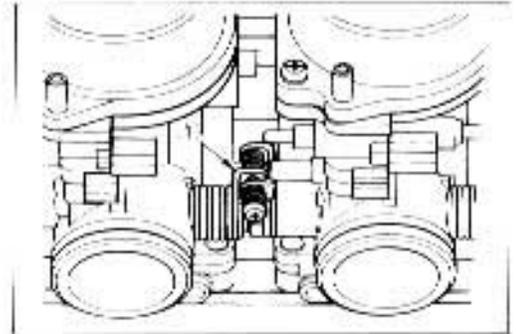

- Apply THREAD LOCK CEMENT to the upper and lower plates screws.

### 99000-32040: THREAD LOCK CEMENT

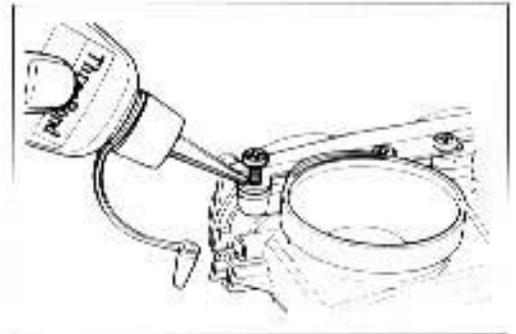

- Set each throttle valve in such a way that its top end (1) meets the foremost bypass (2). This is accomplished by turning the throttle stop screw (3) and balance screws (4).

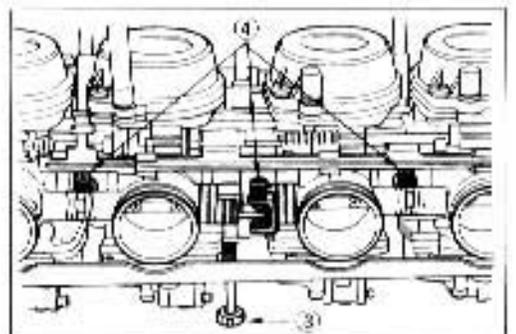
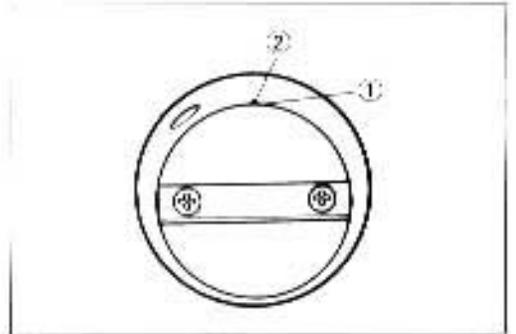

### NOTE:

The order of throttle balance screws adjustment is as follows:

- (A)  
↓  
(B)  
↓  
(C)

After all the work is completed, mount the carburetor assembly and the following adjustment are necessary.

- \* Engine idle r/min..... Page 2-9
- \* Throttle cable play..... Page 2-9
- \* Balancing carburetors..... Page 4-15

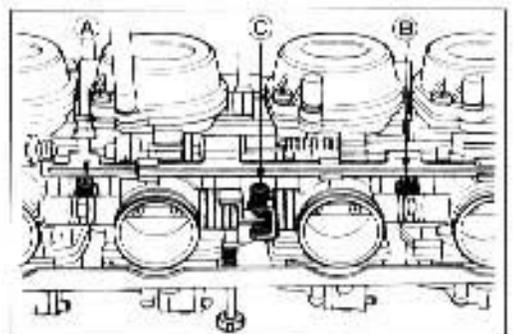

## BALANCE OF CARBURETORS

Check the four carburetors for balancing movement according to the following procedures.

### NOTE:

*When balancing the carburetors, remove the fuel tank and fuel should be supplied by a separate fuel tank and be sure to plug the fuel cock vacuum line.*

### CALIBRATING EACH GAUGE

- Start up the engine and run it in idling condition for warming up.
- Stop the warmed-up engine.
- Remove the vacuum inlet cap (1) for No. 1 or No. 4 cylinder.

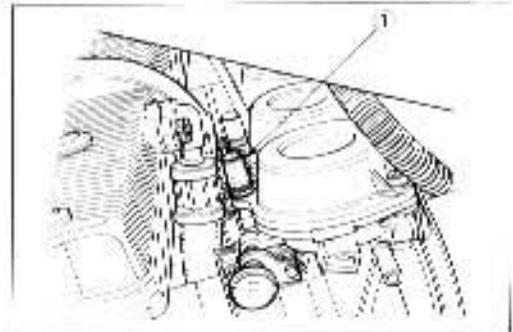

- Connect one of the four rubber hoses of balancer gauge to this inlet

### 09913-13121: Carburetor balancer

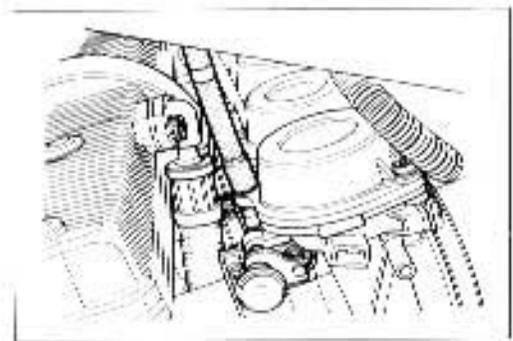

- Start up the engine and keep it running at 1 750 r/min. by turning throttle stop screw (2).

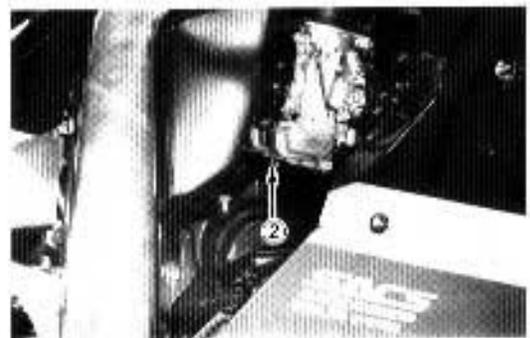

- Turn the air screw (1) of the gauge so that the vacuum acting on the tube of that hose will bring the steel ball (2) in the tube to the center line (3).

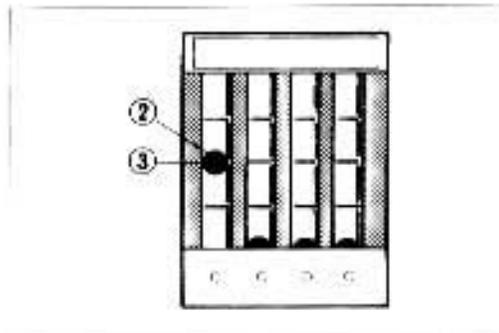
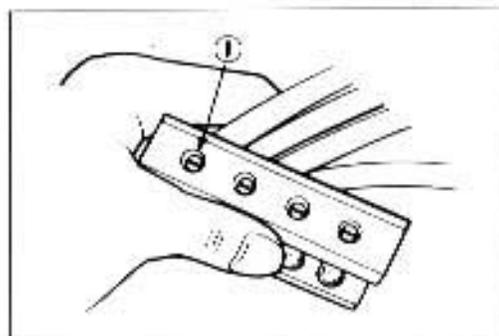

- After making sure that the steel ball stays steady at the center line, disconnect the hose from inlet and connect the next hose to the inlet.
  - Turn air screw to bring the other steel ball (4) to the center line.
  - Repeat the above process on the third and fourth hoses.
- The balancer gauge is now ready for use in balancing the carburetors.

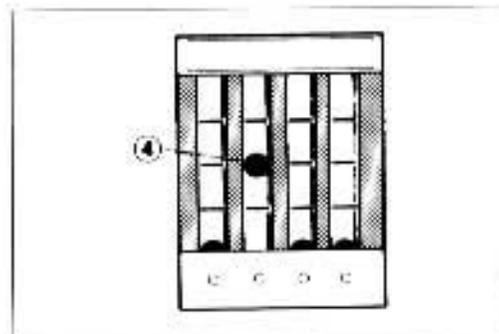

**BALANCING CARBURETORS**

For balancing all the carburetor movement, remove all the vacuum inlet caps from each carburetor. Connect the balancer gauge hoses to these vacuum inlets and adjust the balance of four carburetors as follows.

- Start up the engine, and keep it running at 1 750 r/min. to see engine tachometer reading.  
A correctly adjusted carburetor has the steel balls in the Nos. 1 through 4 tubes at the same level.
  
- If the steel balls are not in correct positions, adjust the throttle valve balance screws correctly.

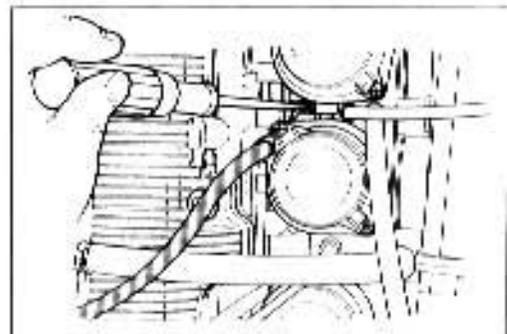
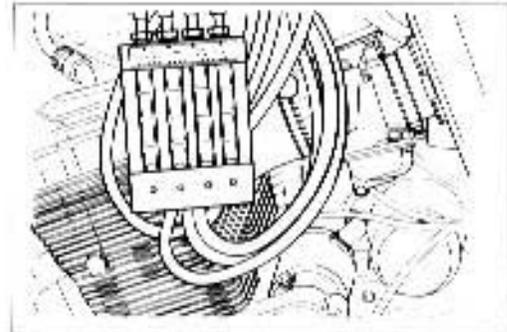

Adjusting order is as follows.

- Ⓐ
- ↓
- Ⓑ
- ↓
- Ⓒ

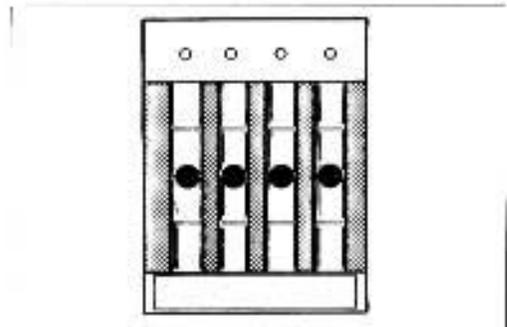
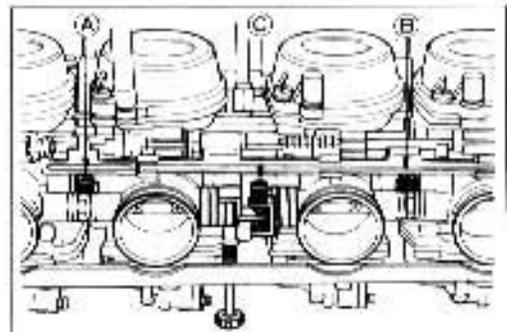

- After balancing the carburetors, set there speed between 1 000 and 1 200 r/min. by turning the throttle stop screw ① referring engine tachometer reading.

Idle r/min: 1 100 ± 100 r/min ..... for E-01 and other models

1 100 ± 100 r/min ..... for E-1B model

1 200 ± 100 r/min ..... for E-03 (Except California model)



**CAUTION:**

Do not disturb the pilot screw. This component is PRE-SET at the factory by the very specialized equipment.

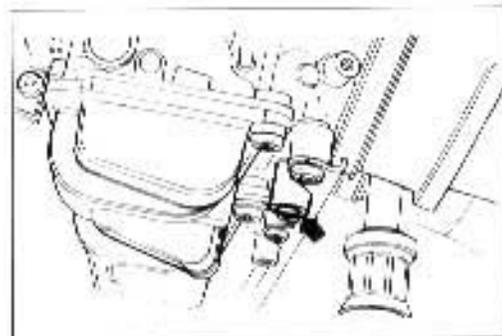

**E-01: General**

**E-03: U.S.A.**

**E-18: Switzerland**

## LUBRICATION SYSTEM

### OIL PRESSURE

Start the engine and check if the oil pressure indicator light is turned on. If it keeps on lighting, check the oil pressure indicator light circuit. If it is in good condition, check the oil pressure in the following manner:

- Remove the main oil gallery plug.
- Install the oil pressure gauge with adaptor (D) in the position shown in the figure.

**09915-74510: Oil pressure gauge**

**09915-77330: Meter (for high pressure)**

**09915-74540: Adaptor**

- Warm up the engine as follows:  
Summer 10 min. at 2 000 r/min.  
Winter 20 min. at 2 000 r/min.

**NOTE:**

*Engine oil must be warmed up to 60°C (140°F) when checking the oil pressure.*

- After warming up, increase the engine speed to 3 000 r/min. with engine tachometer reading and read the oil pressure gauge.

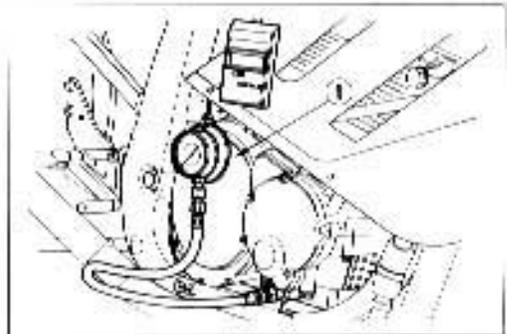
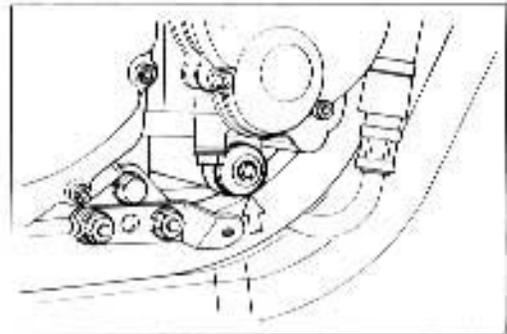

Oil pressure (at 60°C, 140°F)	Above 300 kPa (3.0 kg/cm <sup>2</sup> ) Below 600 kPa (6.0 kg/cm <sup>2</sup> ) at 3 000 r/min.
----------------------------------	---

If the oil pressure is lower or higher than the specification, several causes may be considered.

- \* Low oil pressure is usually the result of a clogged oil filter, oil leakage from the oil passage way, damaged oil seal, a defective oil pump or a combination of these items.
- \* High oil pressure is usually caused by an engine oil which is too heavy a weight, a clogged oil passage, improper installation of the oil filter or a combination of these items.



## OIL FILTER

**NOTE:**

*Grease the O-ring of the oil filter.*

(For U.S.A. model)

99000-25030: SUZUKI SUPER GREASE "A"

(For the other models)

99000-25010: SUZUKI SUPER GREASE "A"

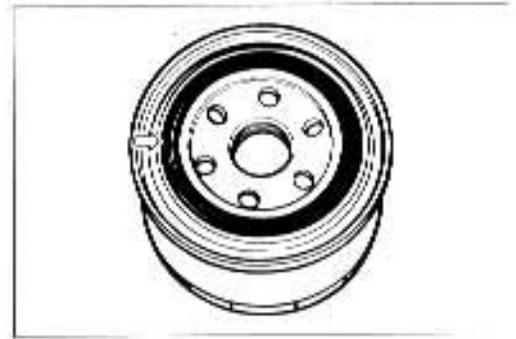

## OIL SUMP FILTER

When you wash the oil pan, check to be sure that the oil sump filter is free from any sign of rupture, also wash the filter clean periodically.

**CAUTION:**

Replace the oil pan gasket and O-ring with new ones to prevent oil leakage.

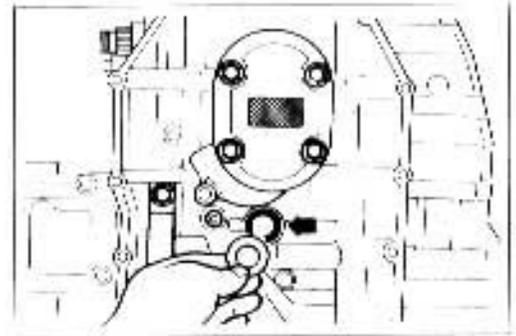

## RELIEF VALVE

Check the hole in the relief valve for clogging.





## ENGINE LUBRICATION SYSTEM

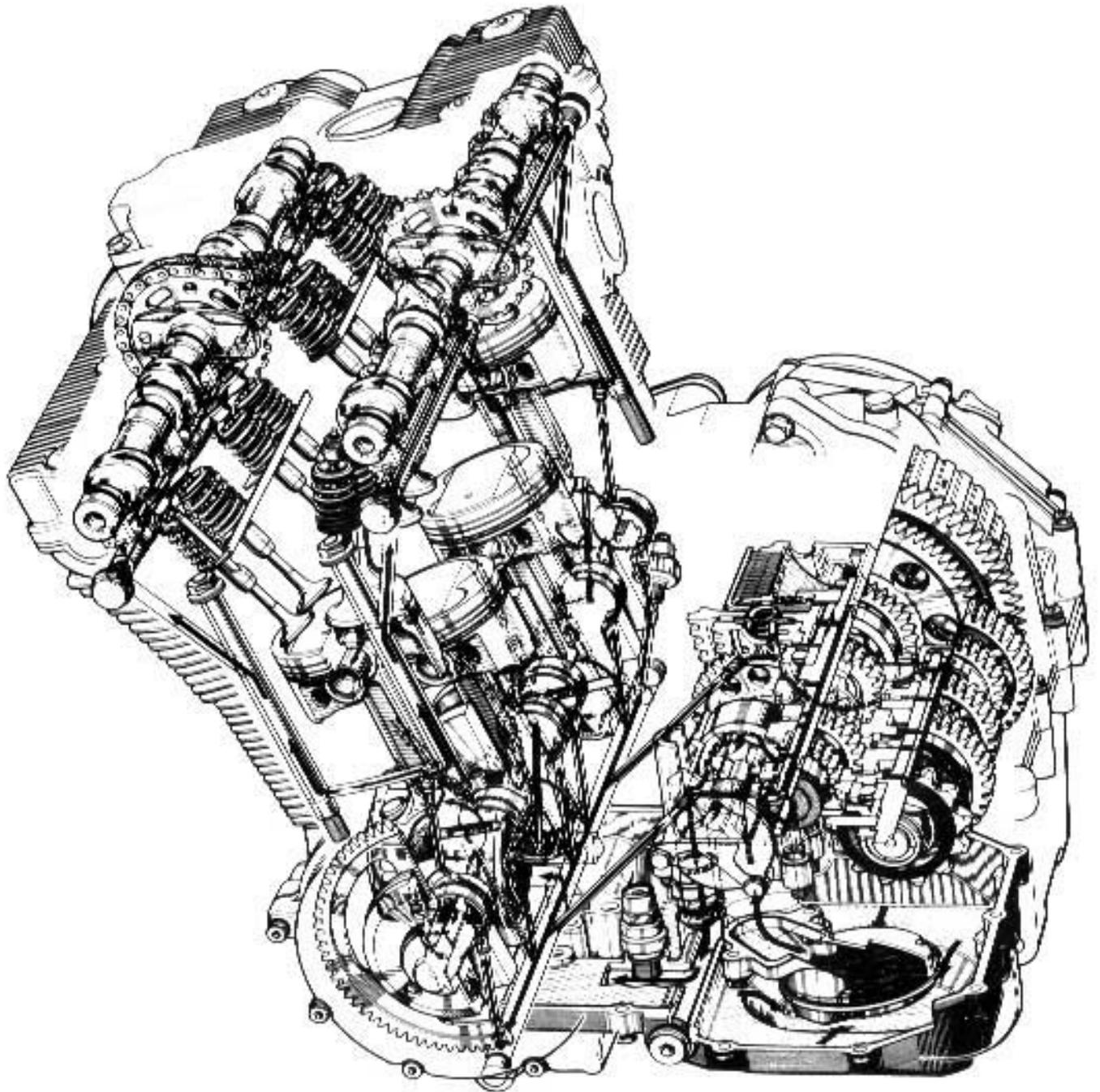

### CYLINDER HEAD COOLING SYSTEM CHART

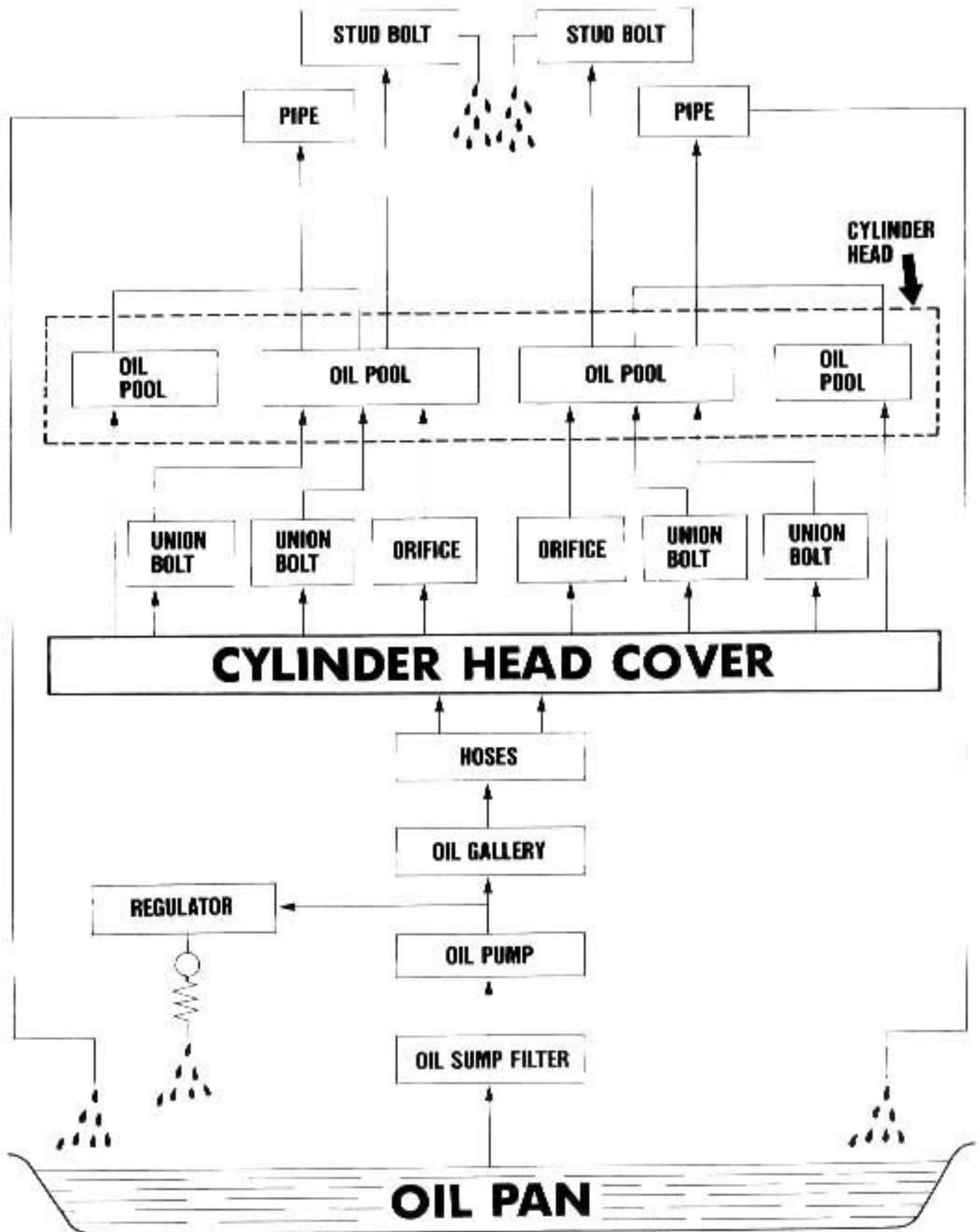

CYLINDER HEAD COOLING SYSTEM

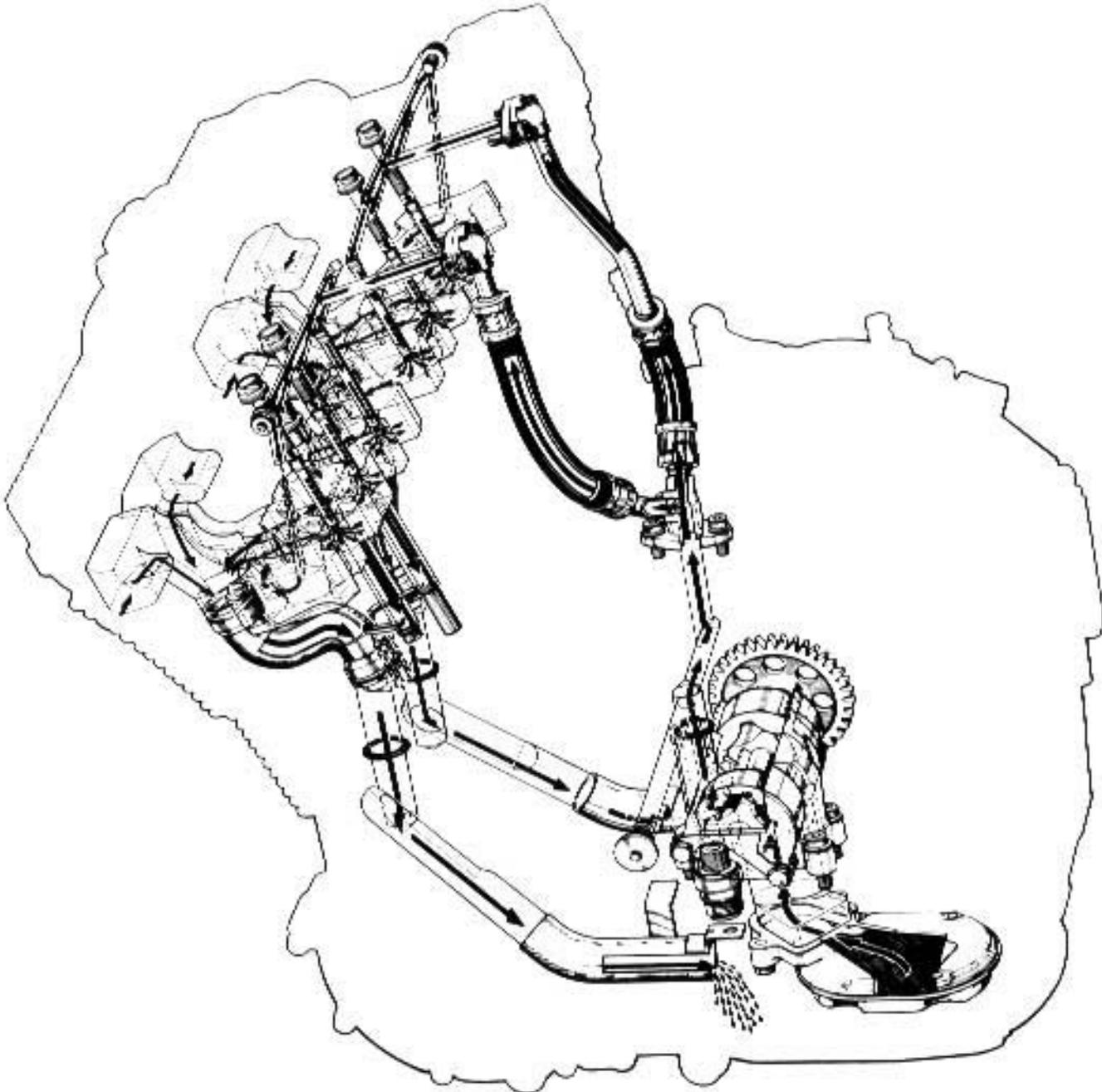

## OIL COOLER

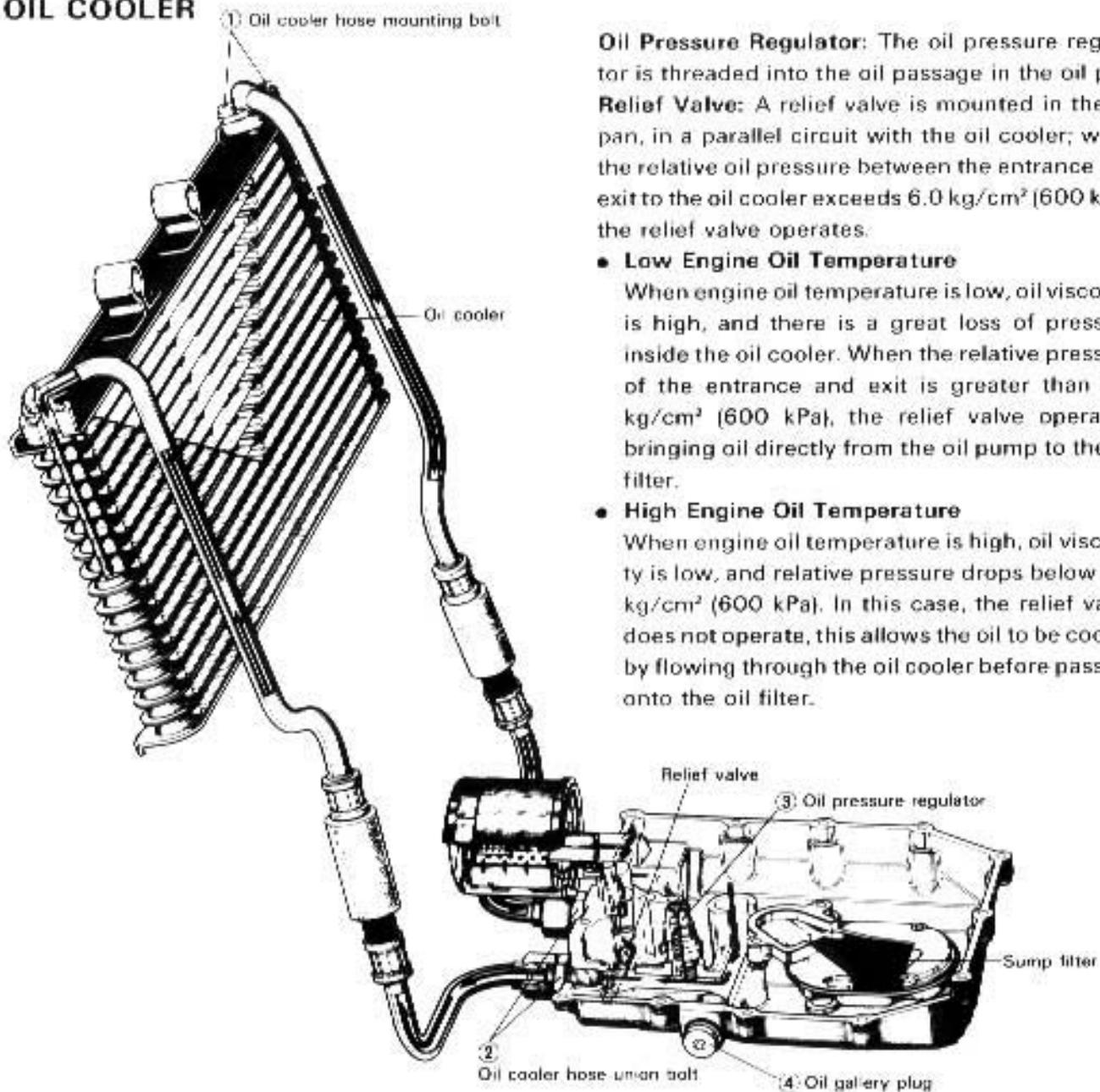

**Oil Pressure Regulator:** The oil pressure regulator is threaded into the oil passage in the oil pan.

**Relief Valve:** A relief valve is mounted in the oil pan, in a parallel circuit with the oil cooler; when the relative oil pressure between the entrance and exit to the oil cooler exceeds 6.0 kg/cm<sup>2</sup> (600 kPa), the relief valve operates.

- **Low Engine Oil Temperature**

When engine oil temperature is low, oil viscosity is high, and there is a great loss of pressure inside the oil cooler. When the relative pressure of the entrance and exit is greater than 6.0 kg/cm<sup>2</sup> (600 kPa), the relief valve operates, bringing oil directly from the oil pump to the oil filter.

- **High Engine Oil Temperature**

When engine oil temperature is high, oil viscosity is low, and relative pressure drops below 6.0 kg/cm<sup>2</sup> (600 kPa). In this case, the relief valve does not operate, this allows the oil to be cooled by flowing through the oil cooler before passing onto the oil filter.

**Oil Cooler:** An oil cooler is used to maintain engine oil temperature within the optimum range by compensating for the heat produced by the engine.

## TIGHTENING TORQUE

ITEM	N·m	kg·m	lb·ft
①	8 - 12	0.8 - 1.2	6.0 - 8.5
③, ④	25 - 30	2.5 - 3.0	18.0 - 21.5
②	35 - 45	3.5 - 4.5	25.5 - 32.5

## OPERATING PRESSURE OF REGULATORS

ITEM	kg/cm <sup>2</sup>	kPa
For lubrication	7.0	700
For cooling	5.0	500

# ELECTRICAL SYSTEM

## CONTENTS

<b>CHARGING SYSTEM</b> .....	5- 1
<b>DESCRIPTION (GENERATOR WITH IC REGULATOR)</b> .....	5- 1
<b>CHARGING OUTPUT CHECK</b> .....	5- 2
<b>REMOVAL AND DISASSEMBLY</b> .....	5- 2
<b>INSPECTION</b> .....	5- 4
<b>REASSEMBLY AND REMOUNTING</b> .....	5- 7
<b>REASSEMBLY INFORMATION</b> .....	5- 9
<b>IGNITION SYSTEM</b> .....	5-10
<b>DESCRIPTION</b> .....	5-10
<b>INSPECTION</b> .....	5-11
<b>STARTER SYSTEM</b> .....	5-15
<b>DESCRIPTION</b> .....	5-15
<b>REMOVAL AND DISASSEMBLY</b> .....	5-15
<b>INSPECTION</b> .....	5-16
<b>REASSEMBLY</b> .....	5-17
<b>STARTER RELAY INSPECTION</b> .....	5-18
<b>SIDE-STAND/IGNITION INTERLOCK SYSTEM</b> .....	5-19
<b>DESCRIPTION</b> .....	5-19
<b>INSPECTION</b> .....	5-20
<b>COMBINATION METER</b> .....	5-22
<b>REMOVAL AND DISASSEMBLY</b> .....	5-22
<b>INSPECTION</b> .....	5-22
<b>FUEL LEVEL INDICATOR</b> .....	5-24
<b>INSPECTION</b> .....	5-24
<b>LAMPS</b> .....	5-25
<b>HEADLIGHT</b> .....	5-25
<b>TAIL/BRAKE LIGHT</b> .....	5-25
<b>TURN SIGNAL LIGHT</b> .....	5-26
<b>SWITCHES</b> .....	5-26
<b>RELAY</b> .....	5-27
<b>STARTER RELAY</b> .....	5-27
<b>SIDE-STAND RELAY</b> .....	5-27
<b>HEADLIGHT RELAY</b> .....	5-27
<b>TURN SIGNAL RELAY</b> .....	5-27
<b>BATTERY</b> .....	5-28
<b>SPECIFICATIONS</b> .....	5-28
<b>INITIAL CHARGING</b> .....	5-28
<b>SERVICING</b> .....	5-28
<b>RECHARGING OPERATION BASED ON S.G. READING</b> .....	5-29
<b>SERVICE LIFE</b> .....	5-30

## CHARGING SYSTEM

### DESCRIPTION (GENERATOR WITH IC REGULATOR)

The generator features a solid state regulator that is mounted inside the generator. All regulator components are enclosed into a solid mold, and this unit is attached to the brush holder frame. The regulator voltage setting cannot be adjusted.

Two brushes carry current through the two slip rings to the rotor coil mounted on the rotor.

The stator windings are assembled on the inside of a laminated core that forms part of the generator housing. A rectifier bridge connected to the stator windings contains six diodes, and electrically changes the stator A.C. voltages to a D.C. voltage which appears at the generator output terminal.

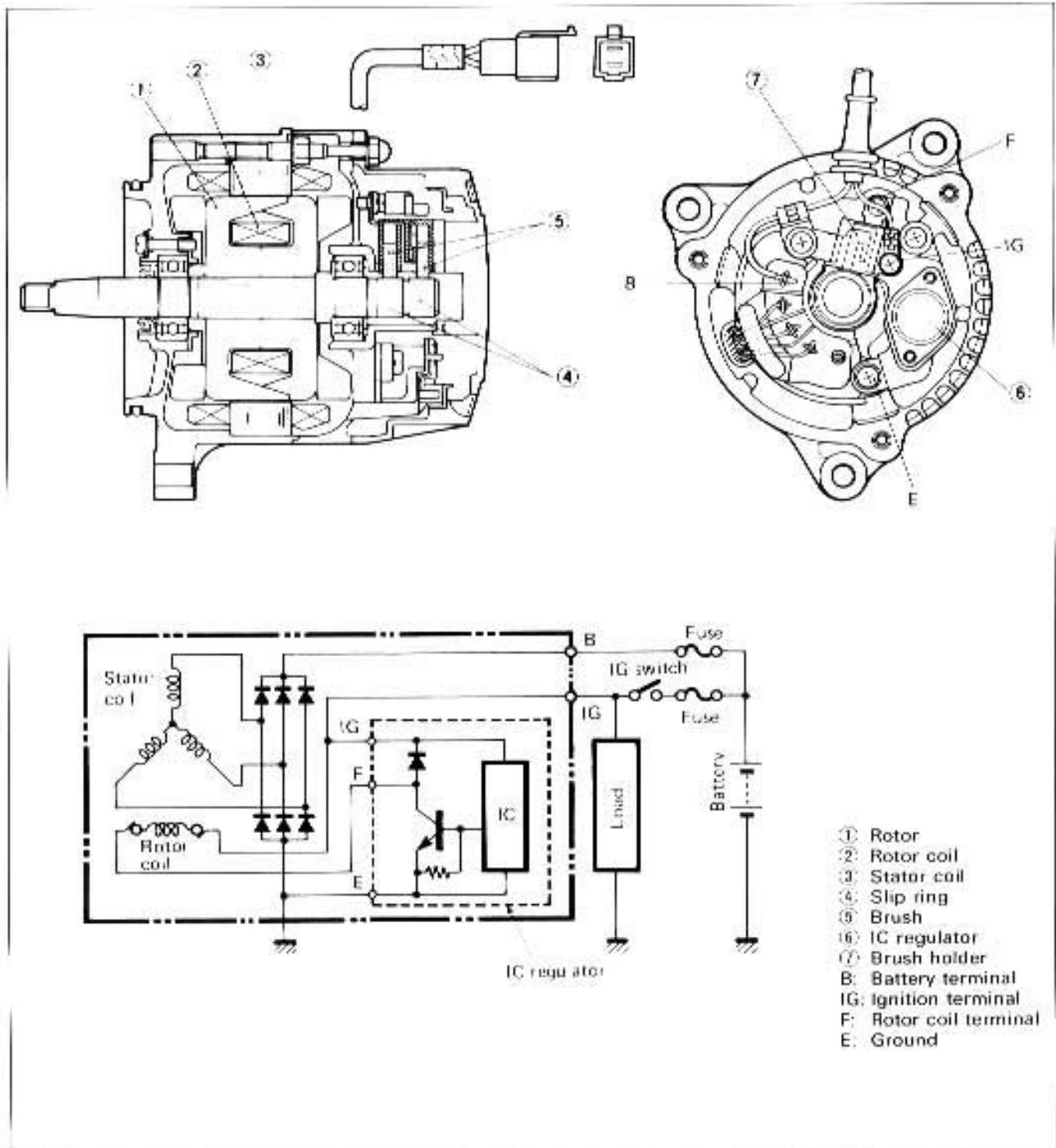



## CHARGING OUTPUT CHECK

- Remove the seat.
- Start the engine and keep it running at 5 000 r/min.
- Measure the DC voltage between the battery terminals.  $\oplus$  and  $\ominus$  with a pocket tester. If the tester reads under 13.5V, check the stator coil, rectifier and IC regulator mounted in the generator.

### CAUTION:

If the pocket tester is set to read current or resistance and a voltage is applied across the test probes, damage will result. Therefore, it is important that the tester knob on the pocket tester be set the proper position before making any measurements.

### NOTE:

When making this test, be sure that the battery is fully-charged condition

09900-25002: Pocket tester

Tester knob indication: DC25V

STD charging output	Above DC13.5V at 5 000 r/min
---------------------	---------------------------------

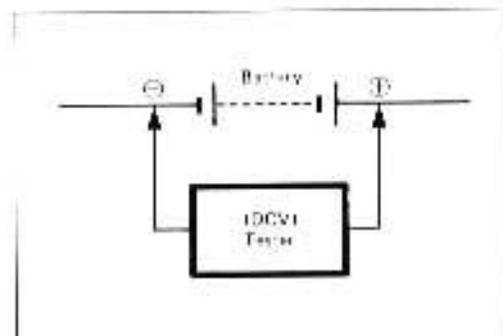
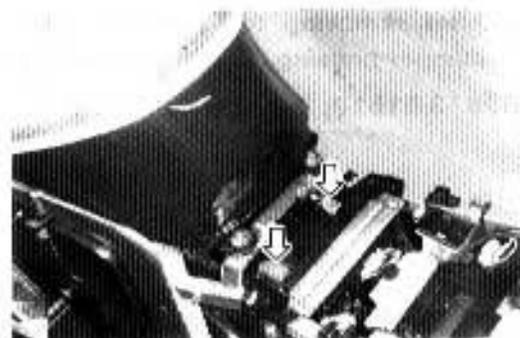

## REMOVAL AND DISASSEMBLY

- Remove the seat.
  - Remove the lower fairing.
  - Disconnect the generator lead wires. (See page 3-6.)
  - Remove the generator.
- 
- Hold the generator driven gear to use a vise and appropriate pieces of woods, and remove the generator driven gear nut as shown.

### CAUTION:

Do not hold the damper housing with a vise, because damage or breakage of the damper housing will result.

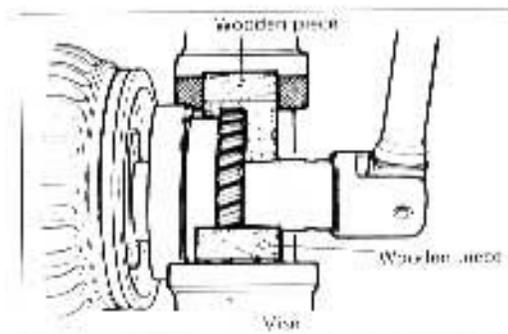

- After removing the generator driven gear, remove the damper housing ① with a bearing puller.

**09913-61510: Bearing puller (80 mm)**

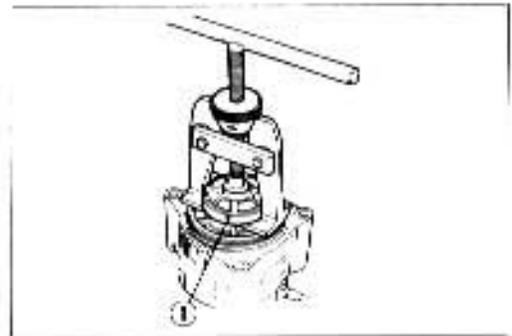

- Remove the generator end cover.

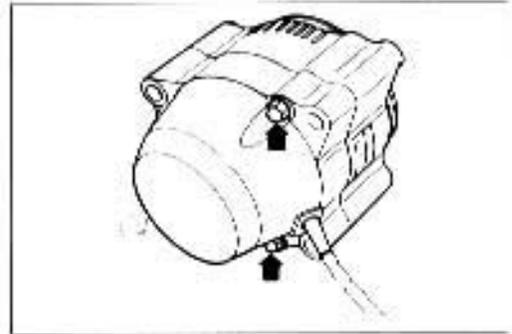

- Disconnect the stator coil lead wires ② and battery lead wire ③ to use a soldering iron.
- Remove the brush holder, IC regulator and rectifier to remove three screws.

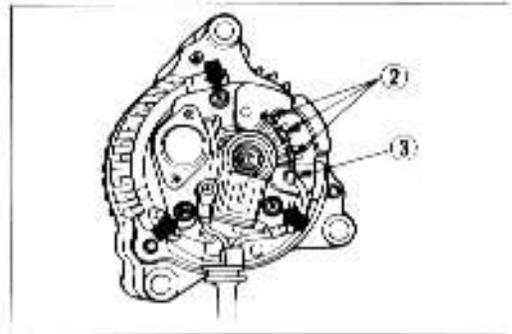

- Remove the three bearing retainer screws.

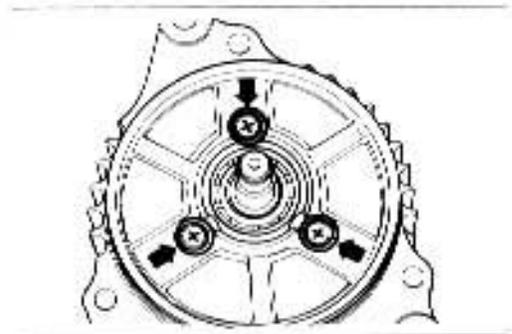

- Separate the generator housing ① from generator end housing ②.

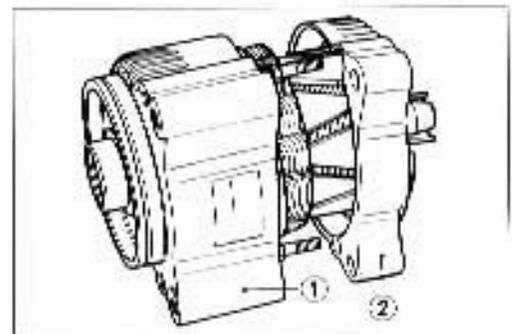

- Remove the rotor (3) from generator end housing (2) to use a hand press (4) as shown.

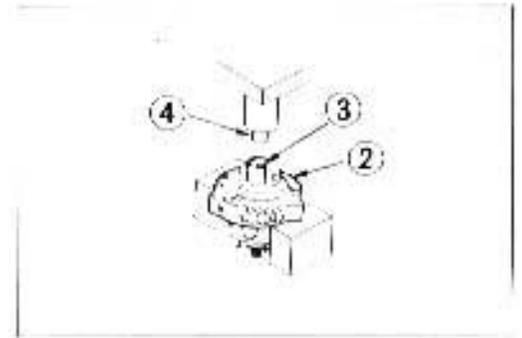

## INSPECTION

### ROTOR BEARING

Inspect the rotor bearings for abnormal noise and smooth rotation to rotate them by hand.

If there is anything unusual, remove the bearing with a bearing puller.

09913-60910: Bearing puller (40 – 60 mm)

#### CAUTION:

The removed bearing should be replaced with a new one.

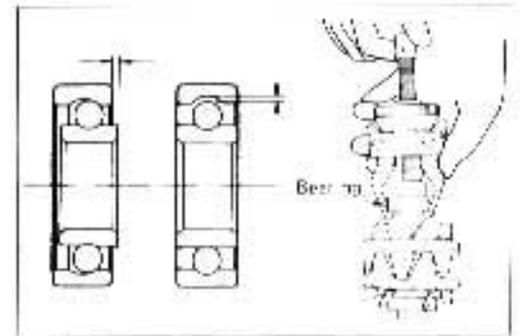

### STATOR COIL CONTINUITY CHECK

Check the continuity between the lead wires of the stator with a pocket tester.

If there is no continuity, replace the stator.  
Also check that the stator core is insulated.

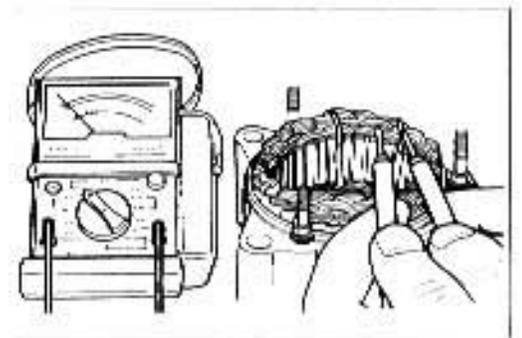

09900-25002: Pocket tester

Tester knob indication:  $\times 1\Omega$  range

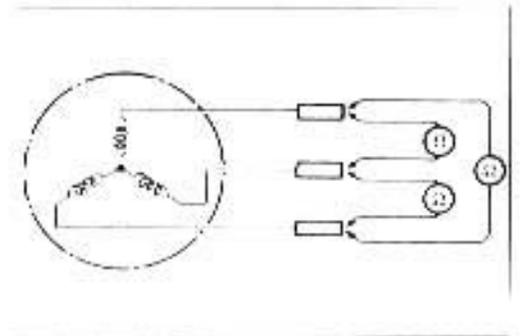

**ROTOR COIL CONTINUITY CHECK**

Check the continuity between the two slip rings of rotor with a pocket tester.

If there is no continuity, replace the rotor.

Also check that the rotor is insulated.

**09900-25002: Pocket tester**

**Tester knob indication: × 1Ω range**

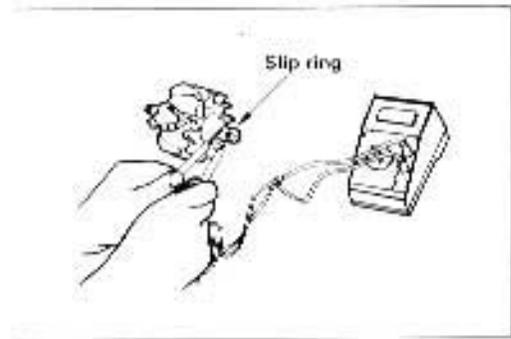

**SLIP RING**

If the slip ring surface is dirty, polish it with #400 fine emery paper to protect the charging performance. After polishing, wipe the slip ring with a clean dry cloth.

**09900-20102: Vernier calipers (200 mm)**

Slip ring O.D.	Service Limit
	14.0 mm (0.55 in)

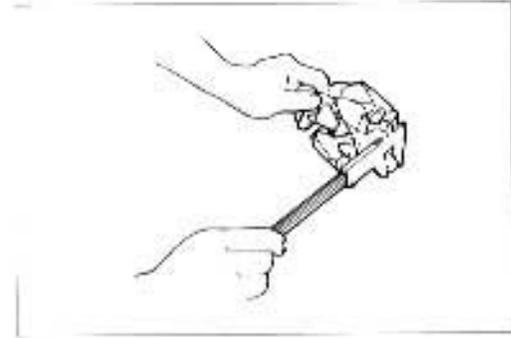

**CARBON BRUSH**

Measure the length of brushes as shown. If it exceeds the service limit, replace them with new ones.

**09900-20102: Vernier calipers (200 mm)**

Brush length	Service Limit
	4.5 mm (0.18 in)

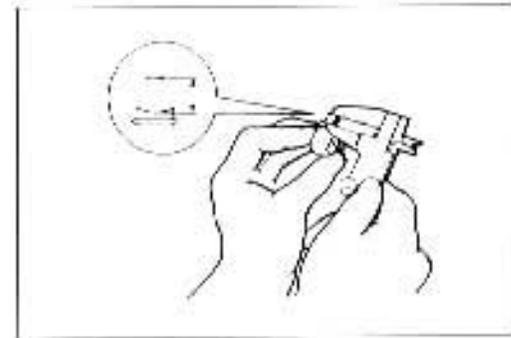

**RECTIFIER**

Check the continuity between terminals and ground. Put one tester lead to terminal "B" and the other lead to ground or other terminals; then swap the two leads. Of the two tester indications, one should be continuity, and the other should be infinity (non continuity). If not, replace the rectifier assembly.

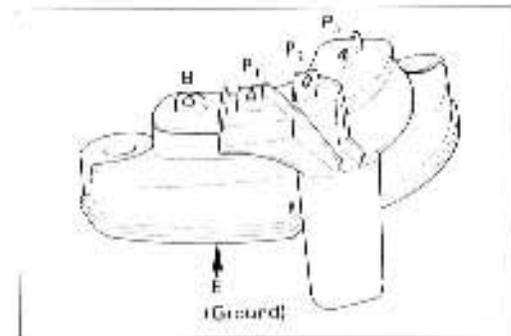

**09900-25002: Pocket tester**

**Tester knob indication: × 1Ω range**

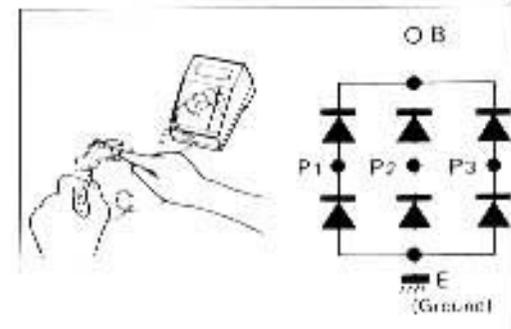

**IC REGULATOR**

Use a variable DC power source, switch, bulb and pocket tester, check the IC regulator, which requires two steps described below:

**First check:**

Set the variable DC power source to 12 V and turn the switch to the ON position. If the bulb does not light, replace the IC regulator. If the bulb is lighting ON, this IC regulator has passed the first check.

**Second check:**

Under the above condition, set the variable DC power source to the 14.5 V, if the bulb goes out, the IC regulator is in good condition. If the bulb remains lit, replace the IC regulator.

**09900-25002 : Pocket tester**

**Tester knob indication : DC25V**

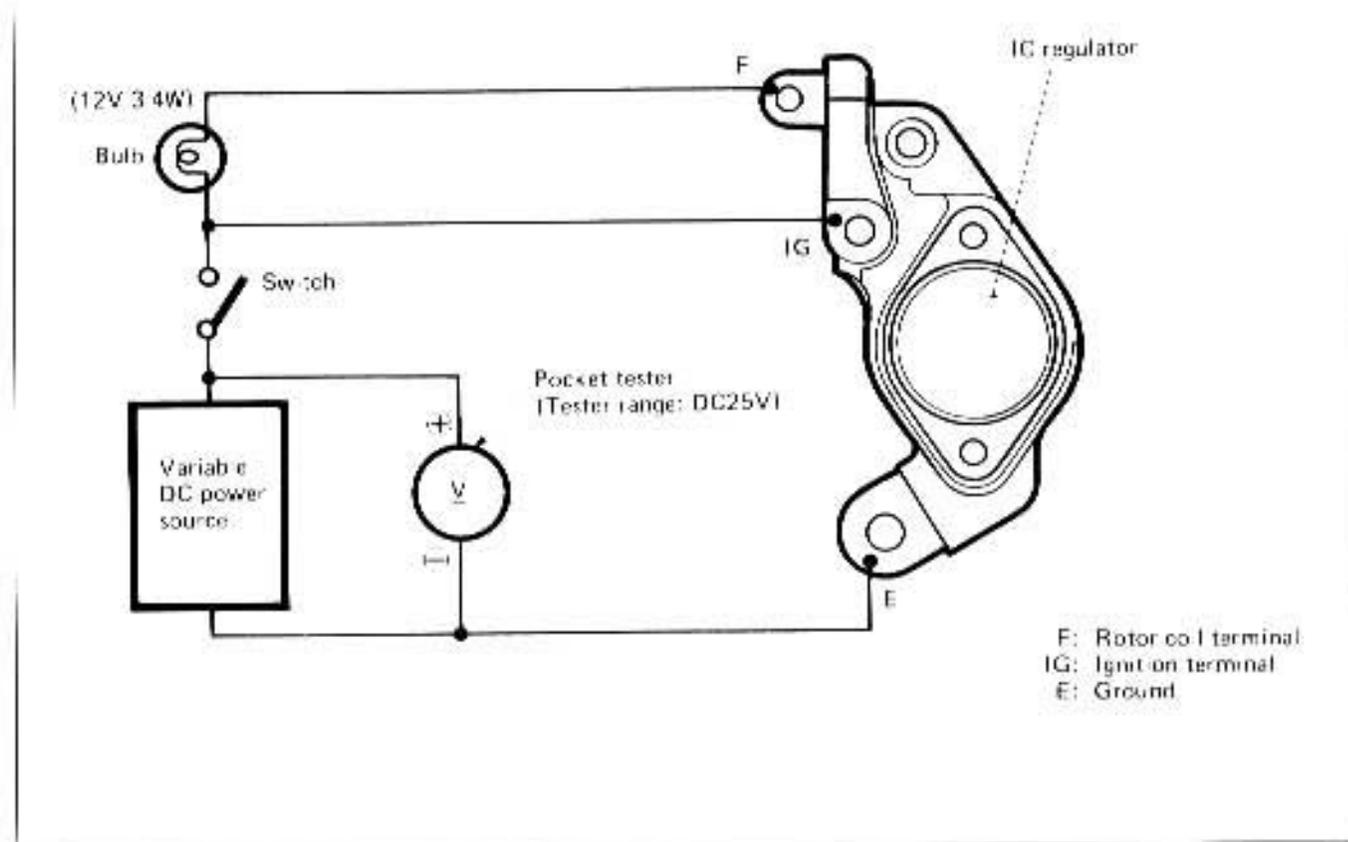
**GENERATOR DRIVEN GEAR DAMPER**

Inspect the dampers for wear and damage. If any defects are found, replace the dampers as a set.

**NOTE:**

When installing the dampers, apply SUZUKI MOLY PASTE to the damper surface.

**99000-25140: SUZUKI MOLY PASTE**

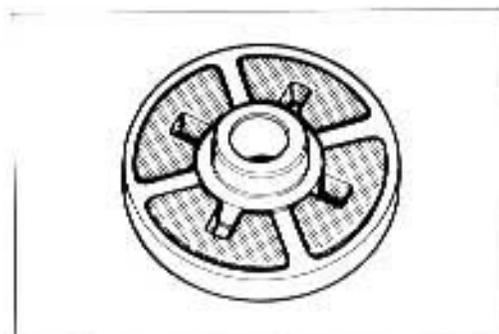

## REASSEMBLY AND REMOUNTING

Reassemble and remount the generator in the reverse order of disassembly and removal. Pay attention to the following points:

- Apply grease to the lip of the oil seal.

(For U.S.A. model)

99000-25030: SUZUKI SUPER GREASE "A"

(For the other models)

99000-25010: SUZUKI SUPER GREASE "A"

### CAUTION:

The removed oil seal and O-rings should be replaced with new ones.

- Install the bearings and rotor to use a hand press as shown.

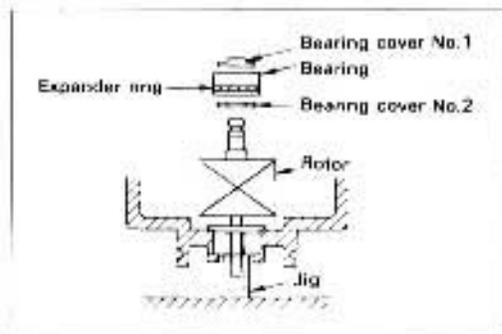
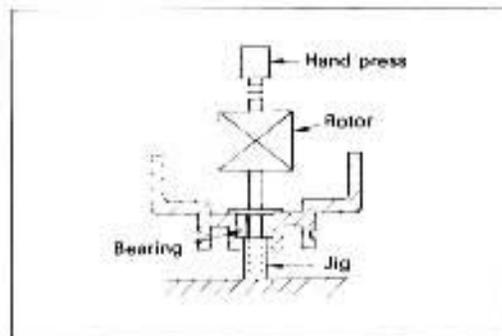
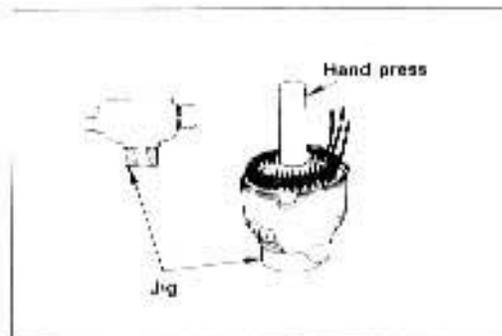
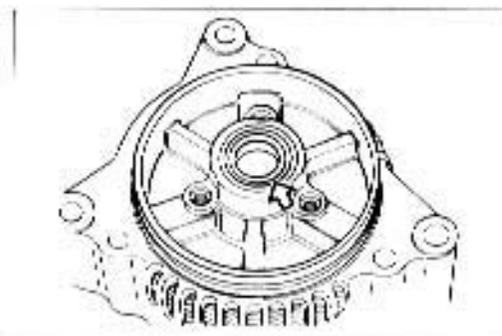

### NOTE:

Before reinstalling the slip ring side bearing to generator end housing, turn the expander ring and align the expander ring lug with the center of chamfer face of bearing outer race.

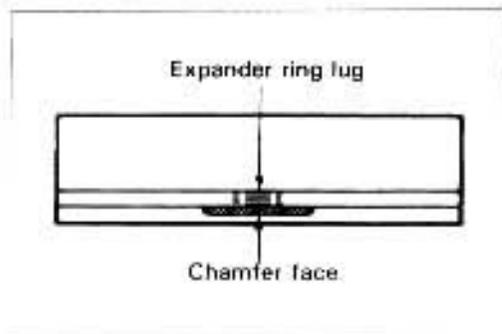

- Fit the three O-rings to the bearing retainer screws

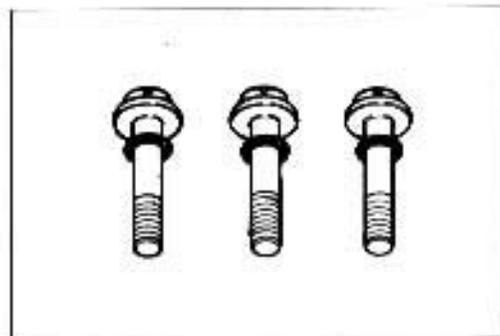

- Apply a small quantity of THREAD LOCK "1342" to the bearing retainer screws.

**99000-32050: THREAD LOCK "1342"**

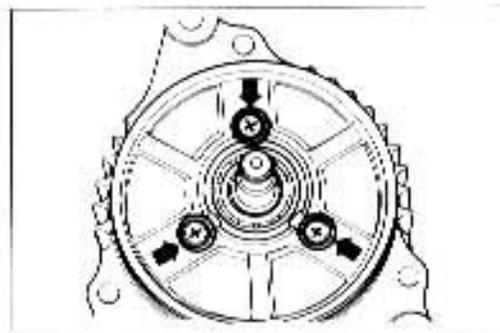

## REASSEMBLY INFORMATION

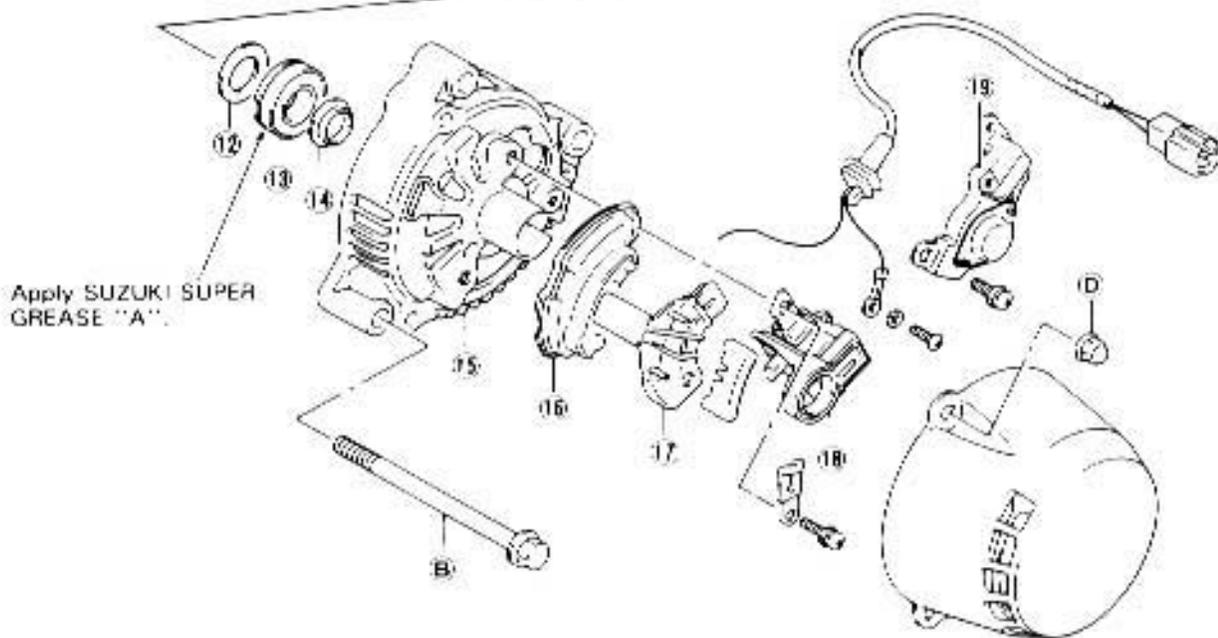
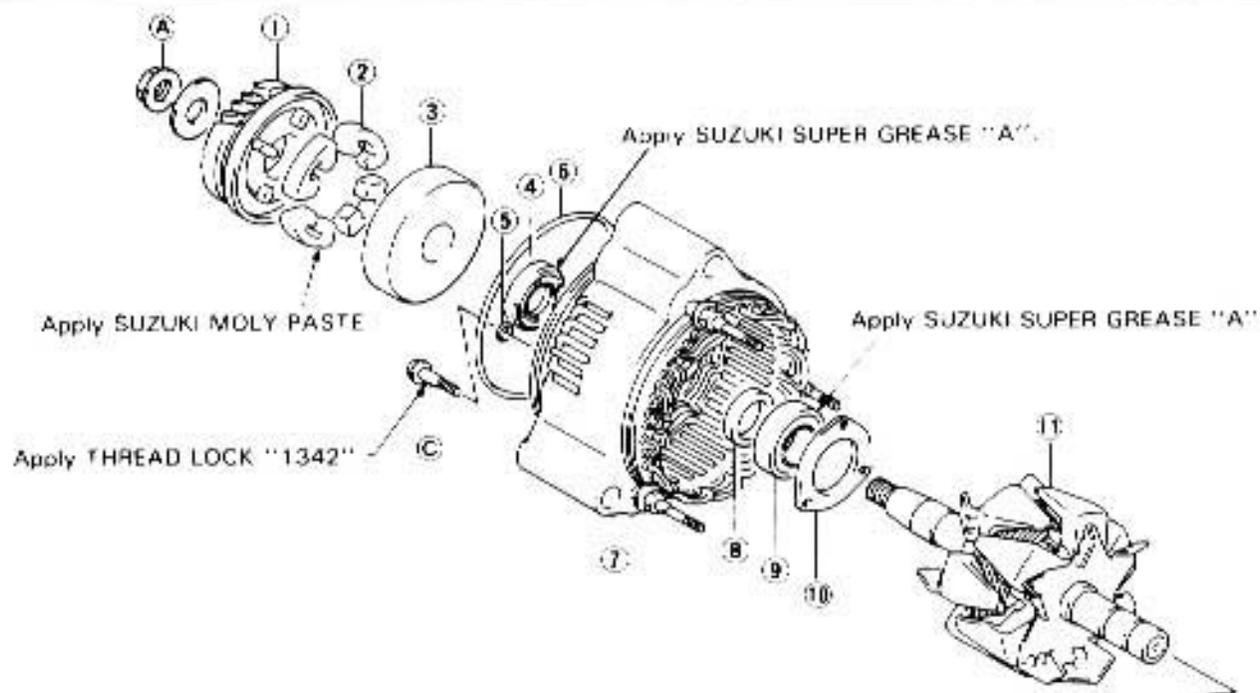

- |                          |                              |
|--------------------------|------------------------------|
| 1: Generator driven gear | 11: Rotor                    |
| 2: Damper (4 pcs)        | 12: Bearing cover No. 2      |
| 3: Damper housing        | 13: Bearing (Slip ring side) |
| 4: Oil seal              | 14: Bearing cover No. 1      |
| 5: O-ring (3 pcs)        | 15: Generator end housing    |
| 6: O-ring                | 16: Rectifier                |
| 7: Generator housing     | 17: Rectifier cover          |
| 8: Spacer                | 18: Brush holder             |
| 9: Bearing (Gear side)   | 19: IC regulator             |
| 10: Bearing retainer     | 20: Generator end cover      |

20

ITEM	Tightening torque		
	N·m	kg·m	lb·ft
⑤	55-65	5.5-6.5	40.0-47.0
⑥	21-29	2.1-2.9	15.0-21.0
⑦	2.2-3.3	0.22-0.33	1.5-2.5
⑩	3.7-5.5	0.37-0.55	2.5-4.0



## IGNITION SYSTEM (DIGITAL IGNITOR)

### DESCRIPTION

The fully transistorized ignition system consists of a signal generator, ignitor unit (including 8-BIT MICROCOMPUTER and CERAMIC 4MHZ VIBRATOR), ignition coils and spark plugs. The characteristic of the ignition timing is programmed and stored in the "ROM" (READ ONLY MEMORY) of the ignitor unit. The signal generator comprises the rotor tip and pickup coil.

The signal generator is mounted at the right end of the crankshaft. The induced signal in the signal generator is sent to wave-form arrangement circuit, and CPU receives this signal and calculates the best ignition timing from the signal of ceramic vibrator and data stored in the ROM. The CPU outputs signal to the transistor of the I.G. coil output circuit which is connected to the primary windings of the ignition coil which is turned OFF and ON accordingly, thus it induces the secondary current on the ignition coil secondary windings and produce the spark between spark plug gaps.

Ignition cut-off circuit is incorporated in the ignitor unit to prevent over-running engine. If engine r/min reaches 10 900 r/min, this circuit cuts off the ignition primary current for all spark plugs.

### CAUTION:

Engine can run over 10 900 r/min. without load, even if the ignition cut-off circuit is effective, and it may cause engine damage. Do not run the engine without load over 10 900 r/min. at anytime.

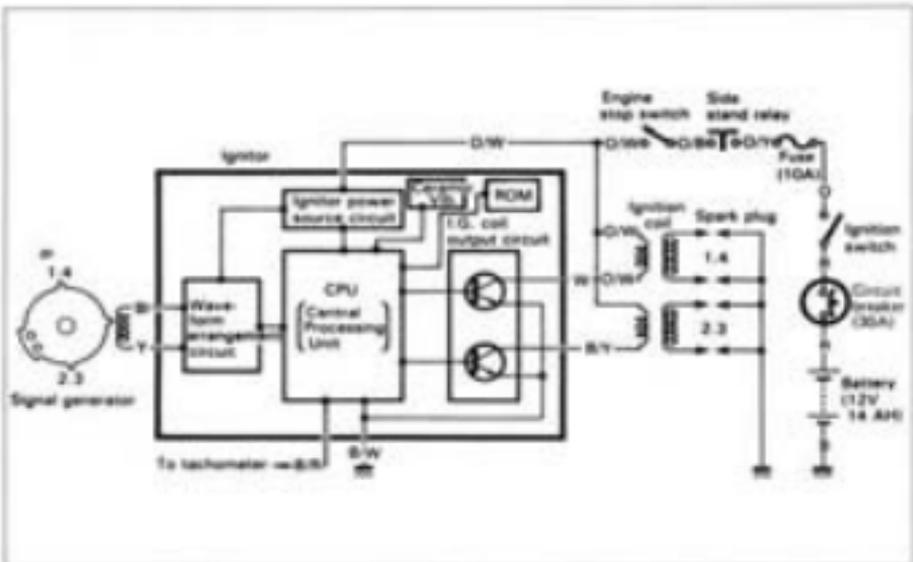

## INSPECTION

## IGNITION COIL (Checking with Electro Tester)

- Remove the seat.
- Remove the fuel tank.
- Remove the ignition coil.

## NOTE:

Make sure that the three-needle sparking distance of electro tester is set at 8 mm (0.3 in).

- With the tester and jumper wire, test the ignition coil for sparking performance in accordance with the following two steps.

STEP (1): Connect the jumper wire to the spark plug cap and ignition coil ground.

STEP (2): Switch over the jumper wire to the other plug cap and ground.

If no sparking or orange color sparking occurs in the above conditions, it may be caused by defective coil.

## 09900-28106: Electro tester

Spark performance	Over 8 mm (0.3 in)
-------------------	--------------------

## IGNITION COIL (Checking with Pocket Tester)

- A SUZUKI pocket tester or an ohm meter may be used, instead of the electro tester. In either case, the ignition coil is to be checked for continuity in both primary and secondary windings. Exact ohmic readings are not necessary, but, if the windings are in sound condition, their continuity will be noted with these approximate ohmic values.

## 09900-25002: Pocket tester

Ignition coil resistance	
Primary	Ⓡ tap - Ⓡ tap 2.4 - 3.2Ω Tester range: (× 1Ω)
Secondary	Plug cap - Plug cap 30 - 40 kΩ Tester range: (× 1 kΩ)

## SIGNAL GENERATOR (Checking with Pocket Tester)

- Remove the seat and disconnect the lead wires.
- Measure the resistance between lead wires. If the resistance is infinity or less than the specifications, the signal generator must be replaced.

## 09900-25002: Pocket tester

Signal coil resistance	Approx. 135 - 200Ω (Y - B)
------------------------	-------------------------------

Tester knob indication: (× 100Ω) range

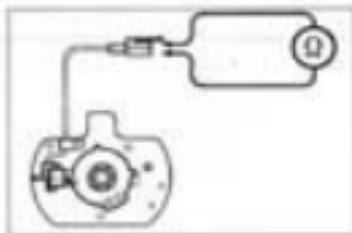
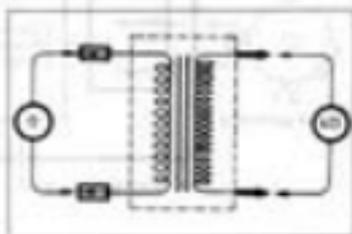
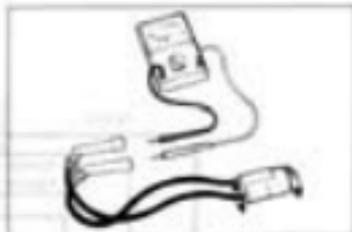
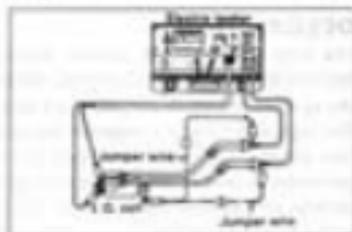

**SPARK PLUGS**

- Remove the seat.
- Remove the fuel tank.
- Remove all the spark plugs.

**Carbon Deposit**

Check to see the carbon deposit on the plug.  
If the carbon is deposited, remove it with a spark plug cleaner machine or carefully using a tool with a pointed end.

**Spark Plug Gap**

Measure the plug gap with a thickness gauge if it is correct.  
If not, adjust it to the following gap.

09900-20803: Thickness gauge

Spark plug gap	Standard
	0.6 - 0.7 mm (0.024 - 0.028 in)

**Electrode's Condition**

Check to see a worn or burnt condition of the electrode. If it is extremely worn or burnt, replace the plug. Also replace the plug if it has a broken insulator, damaged thread, etc.

**Heat Range**

NGK JR9B should be used as the standard. However, the heat range of the spark plug should be selected to meet the requirements of speed, actual load, fuel and etc. Proper heat range would be indicated if all insulators were LIGHT BROWN in color. If they are baked white, they should be replaced with a cold type plug NGK JR10B.

NGK	Standard	Cold type
	JR9B	JR10B

**NOTE:**

"R" type spark plug is installed for some specifications. "R" type spark plug has a resistor located at the center electrode to prevent radio noise.

**CAUTION:**

Confirm the thread size and reach when replacing the plug. If the reach is too short, carbon will be deposited on the screw portion of the plug hole and engine damage may result.

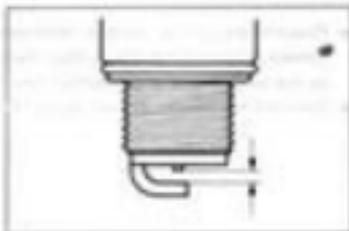
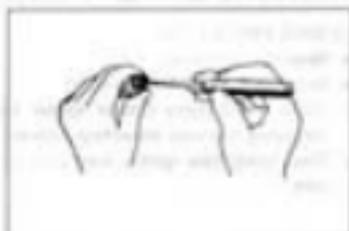

**IGNITOR UNIT (Checking with Digital Ignitor Checker)**

This section explains the checking procedure for the ignitor unit using Digital Ignitor Checker (special tool). With this checker, the ignitor unit can be checked either on the machine or off the machine. The following explains the checking procedure on the machine.

**09931-64410: Digital ignitor checker****WIRING PROCEDURE:**

- Remove both seats.
  - Remove both frame covers.
  - Move the battery holder under cover ① downward by removing the two mounting screws.
  - Disconnect two ignitor lead wire couples ② at the ignitor unit.
- 
- Prepare the ignitor checker lead wire "MODE 1" ③ which comes supplied with the ignitor checker and connect its end to the ignitor unit and another end to the checker.
  - Connect the power source leads ④ to the battery.

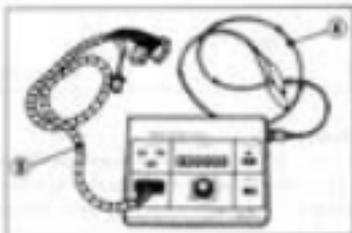
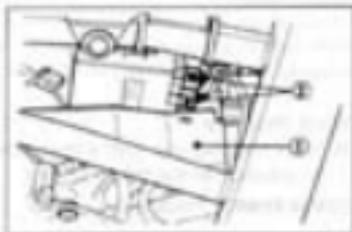
**CAUTION:**

- Be sure that the **BLACK** lead is connected to the battery ⑤ terminal and **RED** lead to the ⑥ terminal.
- Before connecting the power source leads, make sure that both "POWER" button and "START" switch are in "off" position (POWER button not depressed)

**NOTE:**

Be sure that the battery used is in fully-charged condition.

**CHECK PROCEDURE:**

With all the lead wires properly connected, check the ignitor unit in the following three steps.

**First Step:**

Depress "MODE 1" button then "POWER" button. This time, "POWER" lamp should come on, if not, battery is undercharged.

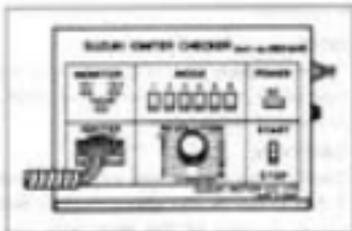

**Second Step:**

Set "REVOLUTION" dial pointer to ".2" position in which the checker produces the ignition primary current pulses simulating 200 r/min of engine revolution when "START" switch is turned on. With "START" switch is turned to ON position, check that three "MONITOR" lamps turn on and off in slow frequency in order of ①-②-③ or ①-③-② as illustrated.

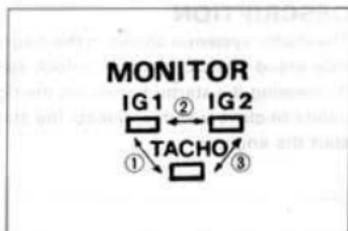
**Third Step:**

Turn "REVOLUTION" dial up gradually (assuming the engine is gradually revved up) and check that the MONITOR lamp flash frequency as explained in the second step above increases. As the dial pointer passes beyond the graduation "1" (1 000 r/min), all the three lamps should show continuously lighted. When REVOLUTION dial pointer reaches between "10" and "11" (10 000 - 11 000 r/min), MONITOR "IG1" and "IG2" lamps should go off while "TACHO" lamp stays on. This is because the ignition "cut-off" provided in the GSX-R1100 ignition system functions at  $10\,900 \pm 100$  r/min. If the lamps go off at the graduation below "10", the engine can not perform properly and therefore the ignitor unit must be replaced.

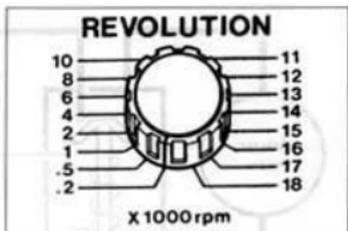
**Fourth Step:**

Turn "START" switch to STOP position. If the "IG1" or "IG2", or both lamps remain light more than 5 seconds, the ignitor unit must be replaced.

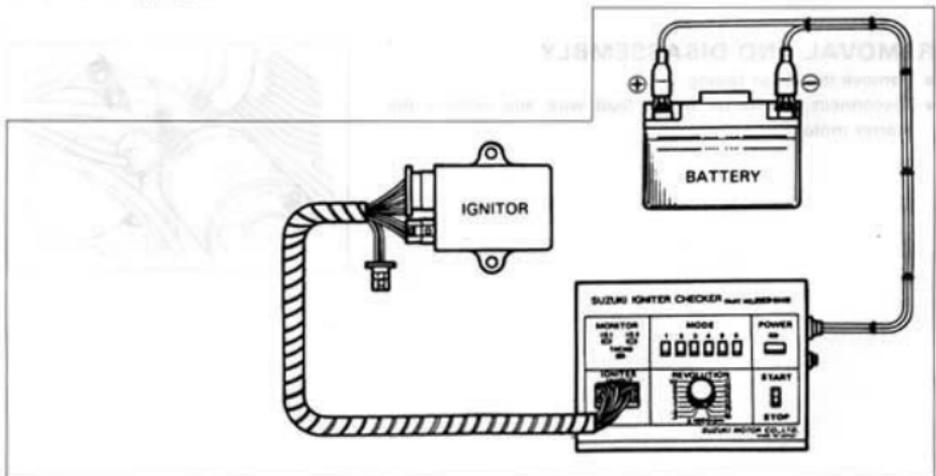

## STARTER SYSTEM

### DESCRIPTION

The starter system is shown in the diagram below: namely, the starter motor, starter relay, side stand relay, side stand switch, clutch interlock switch, starter button, engine stop switch, IG switch and battery. Depressing the starter button (on the right handlebar switch box) energizes the relay, causing the contact points to close which connects the starter motor to the battery. The motor draws about 80 amperes to start the engine.

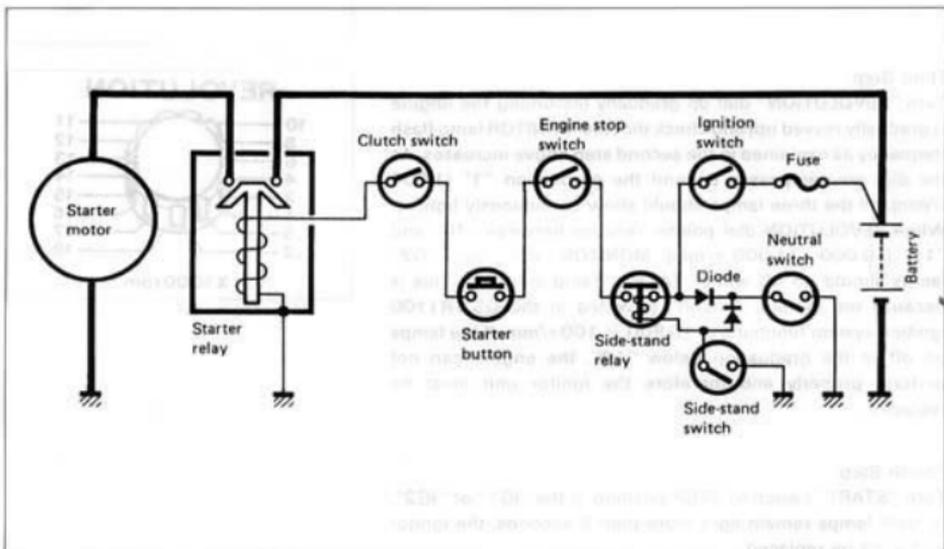

### REMOVAL AND DISASSEMBLY

- Remove the lower fairing.
- Disconnect the starter motor lead wire and remove the starter motor.

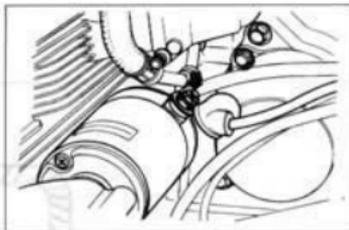

- Disassemble the starter motor as shown in the illustration.

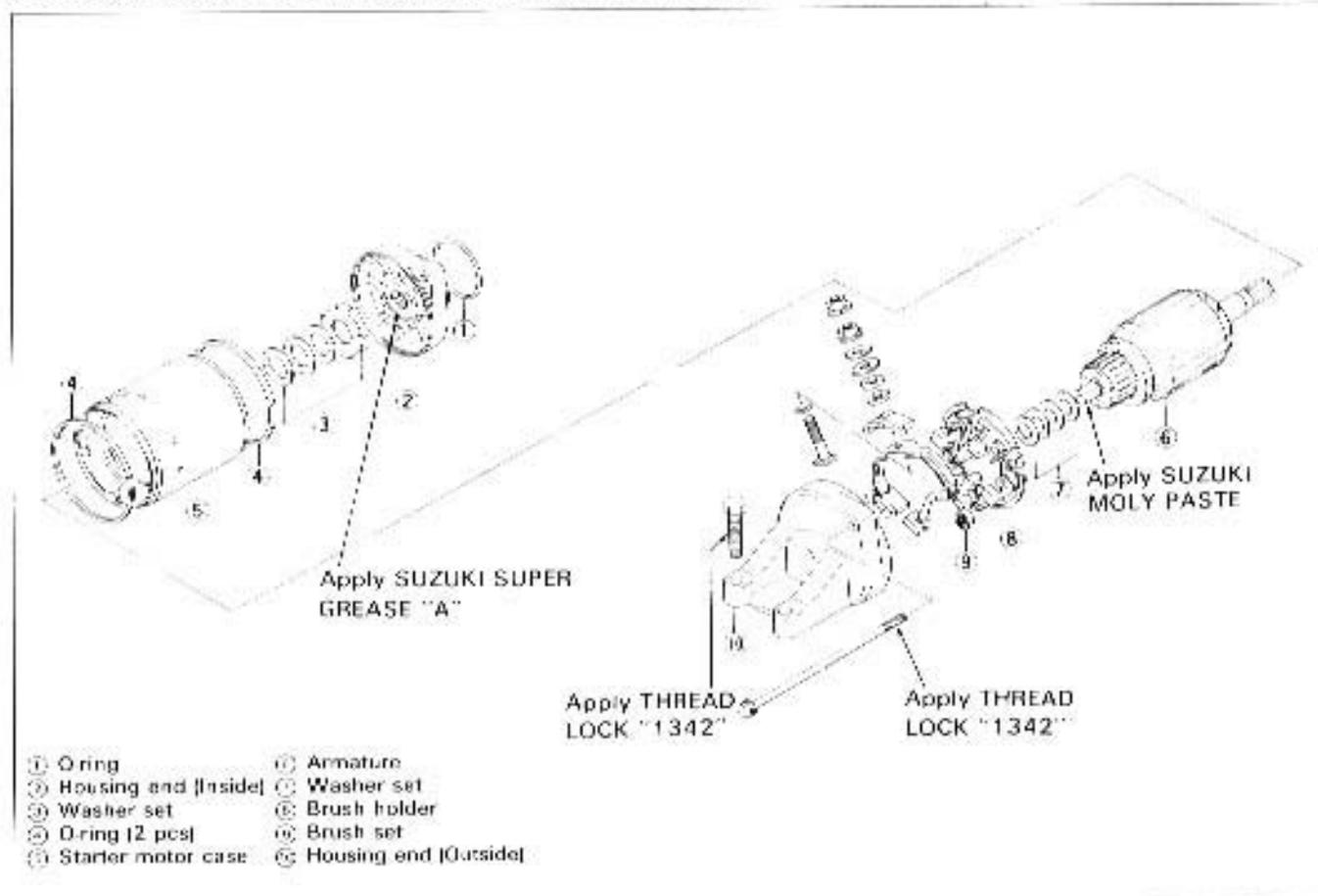

## INSPECTION

### CARBON BRUSH

When the brushes are worn, the motor will be unable to produce sufficient torque, and the engine will be difficult to turn over. To prevent this, periodically, measure the length of the brushes with a vernier calipers, replacing them when they are too short or chipping.

**09900-20102: Vernier calipers (200 mm)**

Brush length	Service Limit
	6 mm (0.2 in)

### COMMUTATOR

If the commutator surface is dirty, starting performance decreases. Polish the commutator with #400 or similar fine emery paper when it is dirty. After polishing it, wipe the commutator with a clean dry cloth.

Measure the commutator under cut ① with a vernier calipers.

**09900-20102: Vernier calipers (200 mm)**

Commutator under-cut	Service Limit
	0.2 mm (0.008 in)

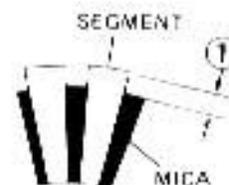
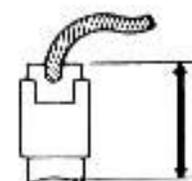

**ARMATURE COIL**

Using a pocket tester, check the coil for open and ground by placing probe pins on each commutator segment and rotor core (to test for ground) and on any two segments at various places (to test for open), with the brushes lifted off the commutator surface.

If the coil is found to be open-circuited or grounded replace the armature. Continuous use of a defective armature will cause the starter motor to suddenly fail.

**09900-25002: Pocket tester**

**Tester knob indication:** X 1Ω range

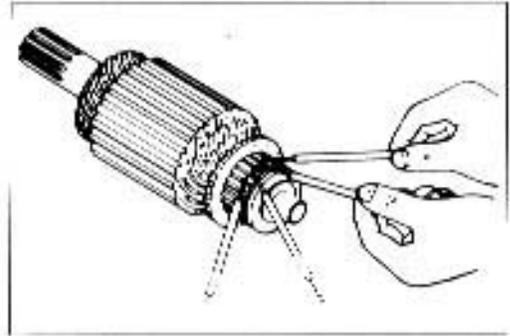
**OIL SEAL**

Check the seal lip for damage or oil leakage. If any damage is found, replace it.

**REASSEMBLY****O-RING****CAUTION:**

**Replace the O-rings with new ones to prevent oil leakage and moisture.**

**HOUSING END (Inside)**

- Apply grease to the lip of oil seal. (Refer to page 5-16.)

(For U.S.A. model)

**99000-25030: SUZUKI SUPER GREASE "A"**

(For the other models)

**99000-25010: SUZUKI SUPER GREASE "A"**

**HOUSING END (Outside)**

- Apply a small quantity of SUZUKI MOLY PASTE to the armature end. (Refer to page 5-16.)

**99000-25140: SUZUKI MOLY PASTE**

- Apply a small quantity of THREAD LOCK "1342" to the starter motor housing screws. (Refer to page 5-16.)

**99000-32050: THREAD LOCK "1342"**



## STARTER RELAY INSPECTION

- Disconnect the lead wire of starter motor at starter relay which is located under the battery holder.

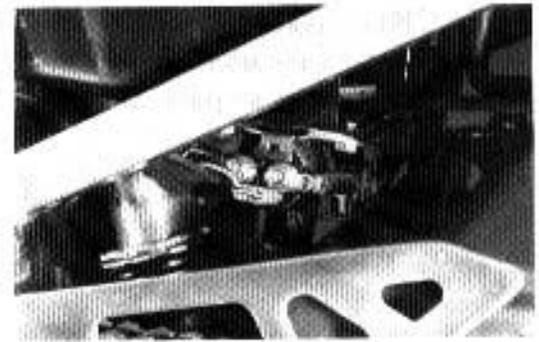

- Turn on the ignition switch, inspect the continuity between the terminals, positive and negative, when squeezing the clutch lever and pushing the starter button. If the starter relay is in sound condition, continuity is found.

09900-25002: Pocket tester

Tester knob indication:  $\times 1\Omega$  range

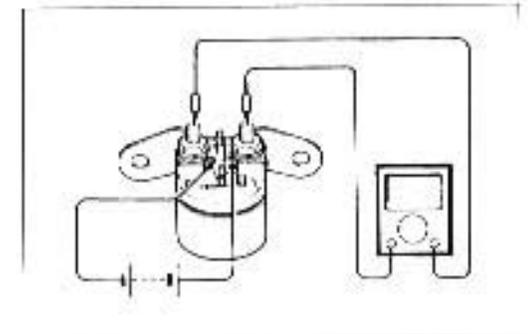

- Disconnect the lead wires from the starter relay.
- Check the coil for "open", "ground" and ohmic resistance. The coil is in good condition if the resistance is as follows.

09900-25002: Pocket tester

Tester knob indication:  $\times 1\Omega$  range

Starter relay resistance	Standard
	3 - 5 $\Omega$

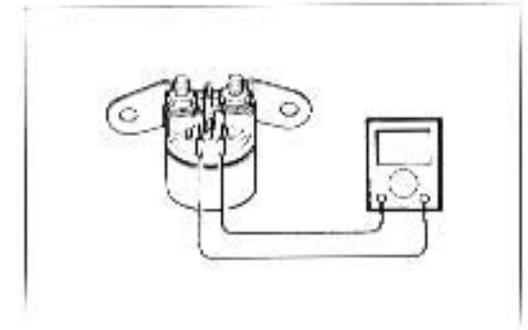

## SIDE-STAND/IGNITION INTERLOCK SYSTEM

### DESCRIPTION

This side-stand/ignition interlock system is to prevent starting the motorcycle with the side-stand left down. The system is operated by an electric circuit provided between the battery and ignition coil.

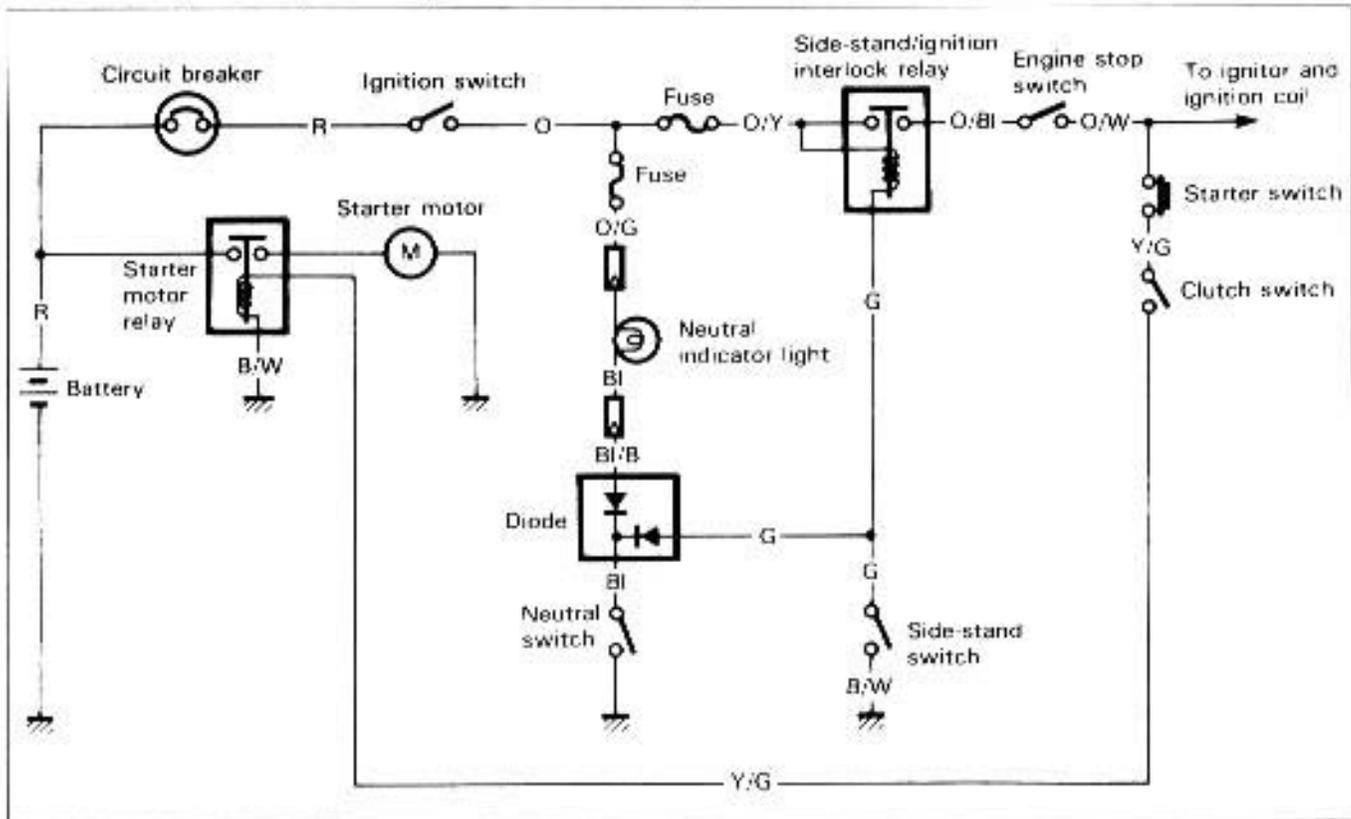

The circuit consists of relay, lamp, diode and switches and decides to live the ignition coil depending on the position of the TRANSMISSION and SIDE-STAND with the neutral and side-stand switches working mutually.

The ignition coil lives only in two situations as follows:

1. Transmission: "NEUTRAL (ON)" Side-stand: "DOWN (OFF)"

The current flow  $\textcircled{A}$  turns "ON" the relay and the ignition coil lives even the side-stand is kept down. This is for warming up the engine.

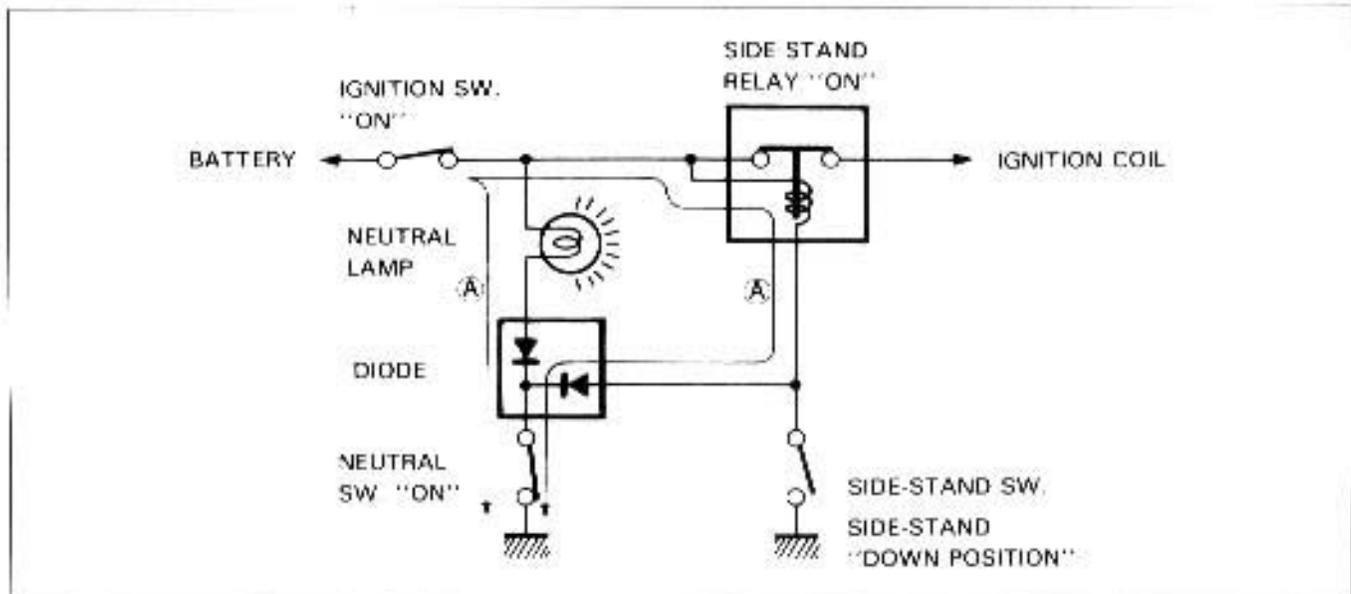

## 2. Side-stand: "UP-RIGHT (ON)"

The current flow  $\textcircled{B}$  turns "ON" the relay and the ignition coil lives. The engine can be easily started at any transmission position.

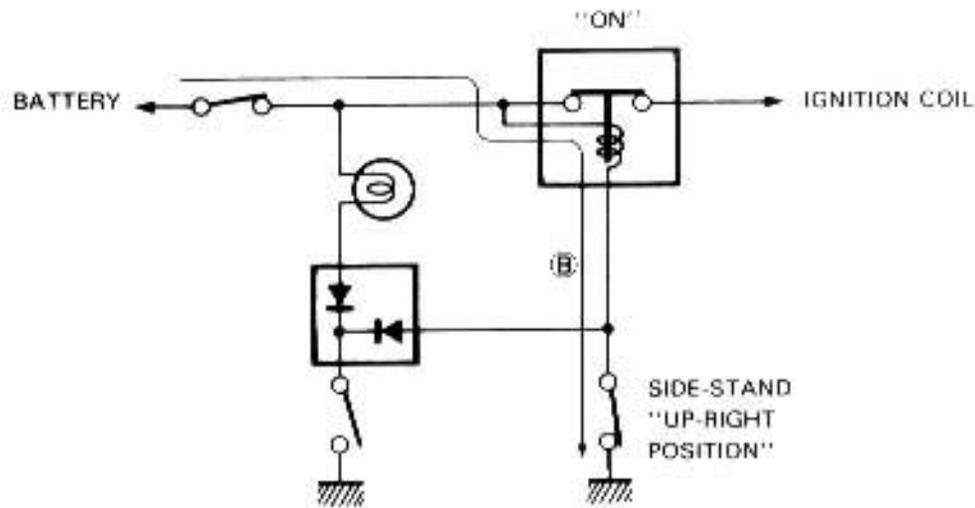

## INSPECTION

If the interlock system does not operate properly, check each component. If any abnormality is found, replace the component with a new one.

**09900-25002: Pocket tester**

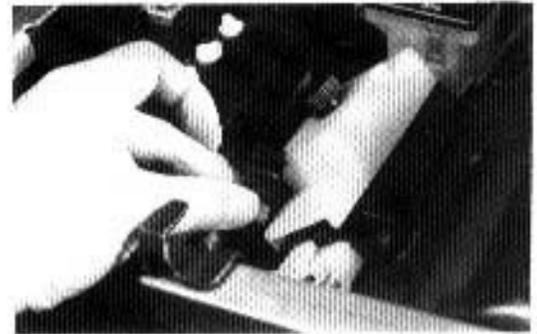

### Diode

The diode is located ahead of the fuse box.

The diode can pass current only in one direction.

- Check the continuity between ① and ②. If one way continuity the diode is in good condition.
- Also check the continuity between ② and ③ as required.

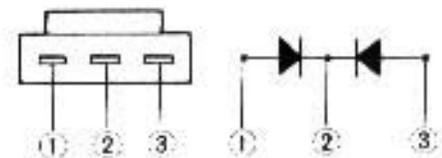

**Neutral switch**

- Disconnect the neutral switch lead and check the continuity between BI and ground with the transmission in "NEUTRAL".

**Side-stand switch**

	G	B/W
ON (UP-right position)	○	○
OFF (Down position)		

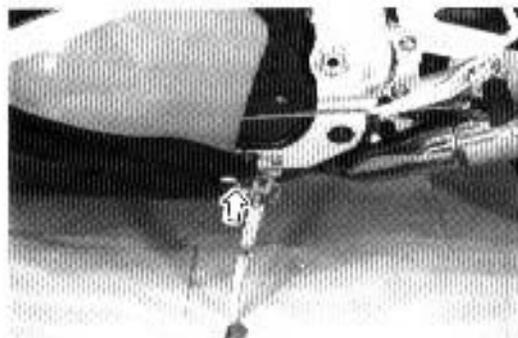
**Side-stand/ignition interlock relay**

The side-stand/ignition interlock relay is located under the battery holder.

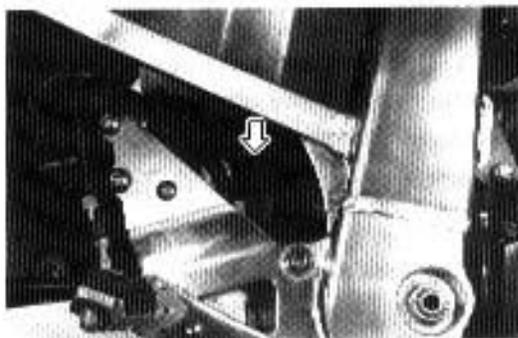

First check the insulation between ① and ② terminals with pocket tester. Then apply 12 volts to ③ and ④ terminals, ⊖ to ③ and ⊕ to ④, and check the continuity between ① and ②. If there is no continuity, replace it with a new one.

**09900-25002: Pocket tester**

**Tester knob indication: × 1Ω range**

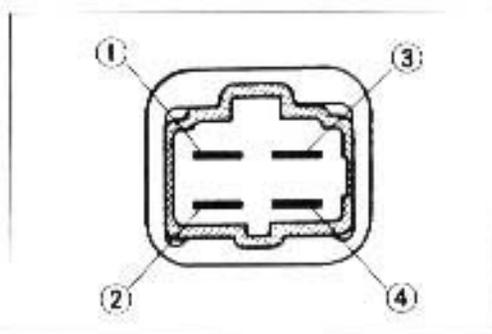

## COMBINATION METER

### REMOVAL AND DISASSEMBLY

- Remove the upper fairing with the wind screen.
- Disassemble the combination meter as follows.

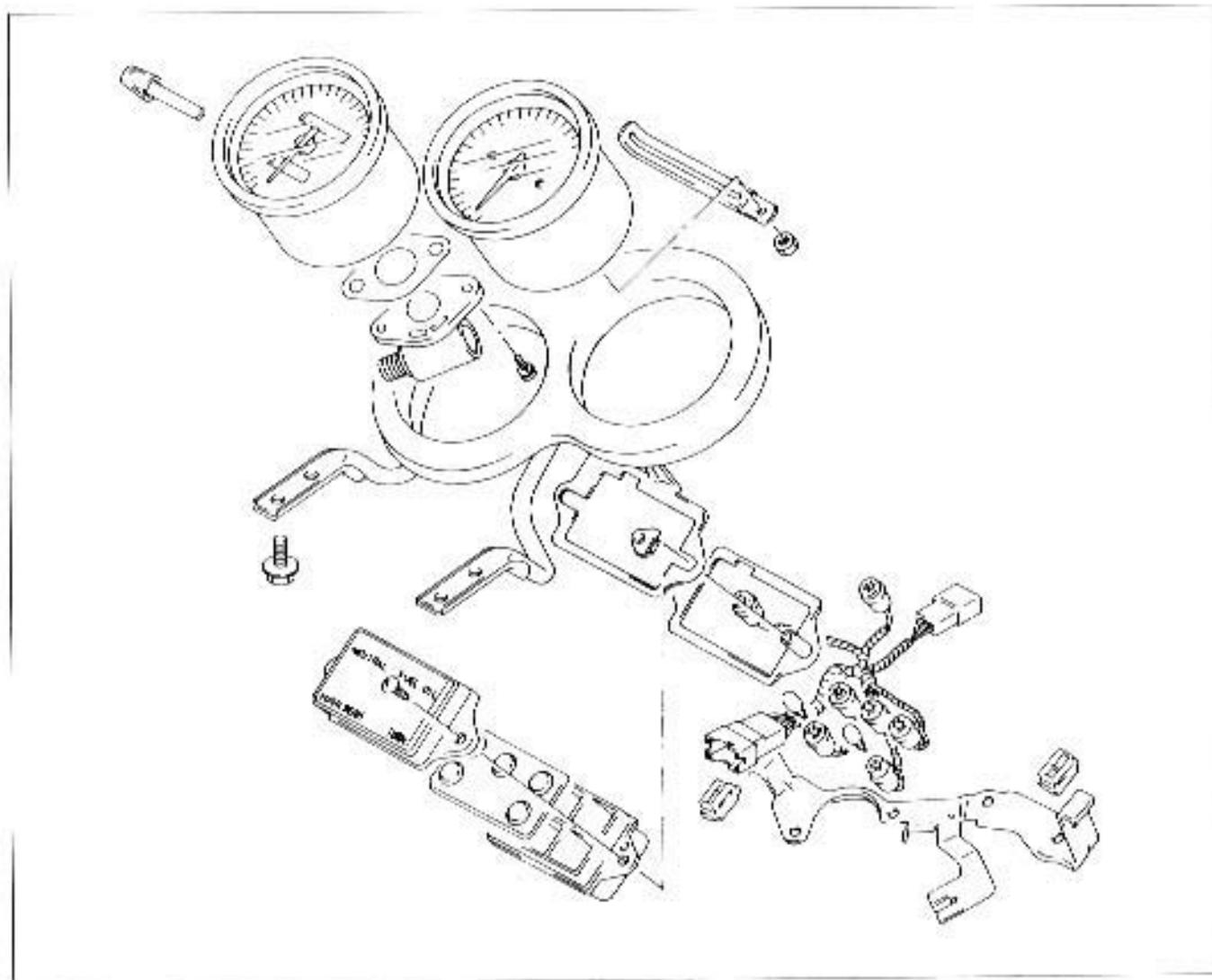

### INSPECTION

Using the pocket tester, check the continuity between lead wires in the diagram on next page.

If the continuity measured is incorrect, replace the respective parts.

**09900-25002: Pocket tester**

**Tester knob indication:**  $\times 1\Omega$  range

#### NOTE:

*When making this test, it is not necessary to remove the combination meter.*

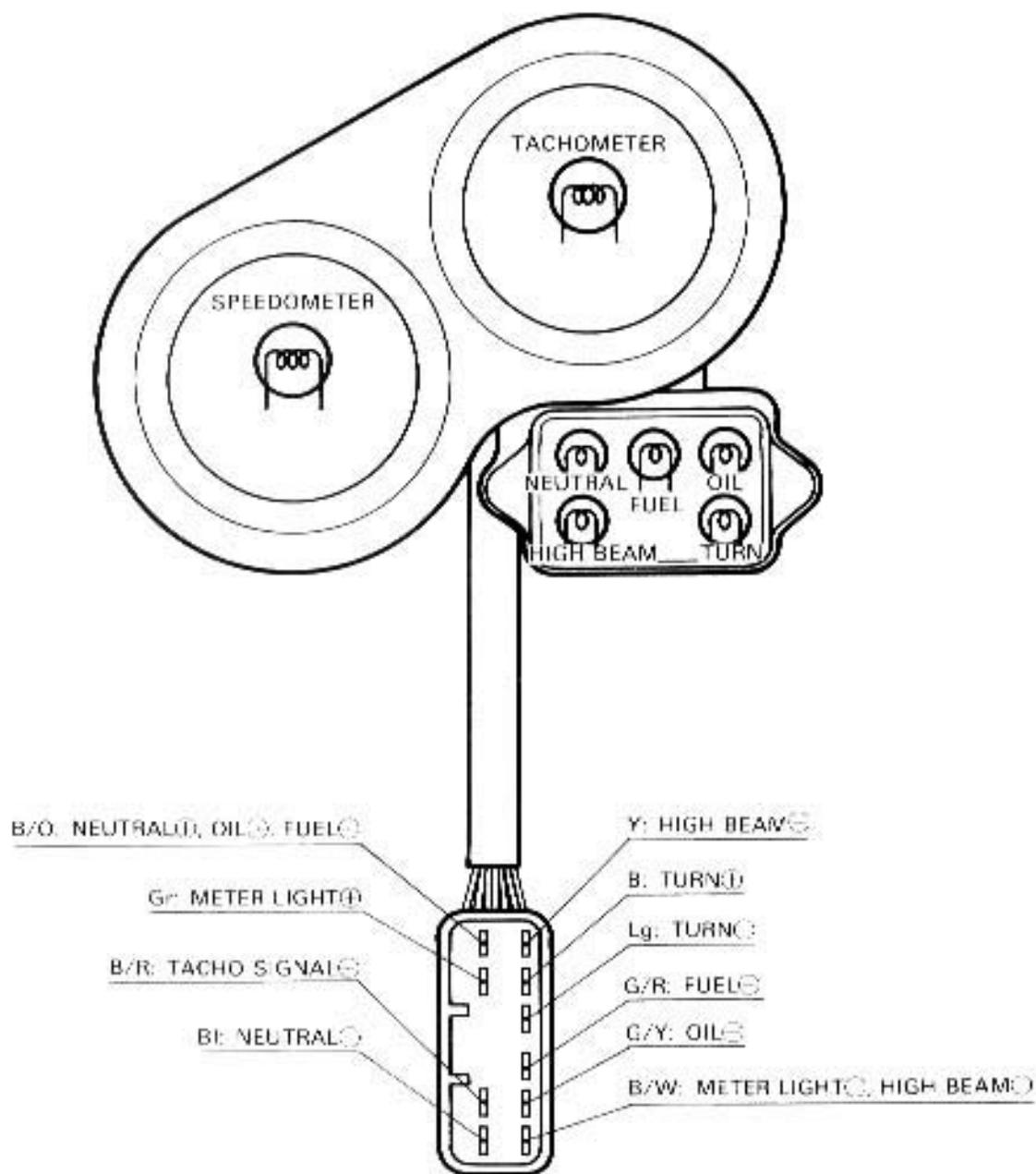

ITEM	(⊖) Probe of tester to:	(⊕) Probe of tester to:
TURN	B	Lg
HIGH BEAM	Y	B/W
NEUTRAL	B/O	Bl
OIL	B/O	G/Y
FUEL	B/O	G/R
METER LIGHT	Gr	B/W

# FUEL LEVEL INDICATOR

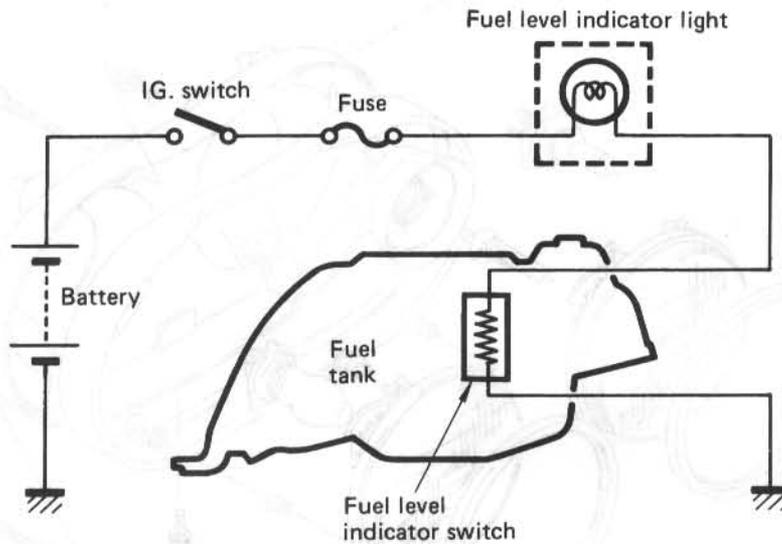

## INSPECTION

- Remove the seat.
- With the ignition switch turned on, disconnect the two lead wires going into the fuel level indicator switch, connect the lead wires from the main wiring harness with a jumper lead and check whether the fuel level indicator light is ON. If a "LIGHT" is indicated, the circuit of fuel level indicator light is in good condition. If the fuel level indicator light does not light, replace the indicator bulb or repair the circuit connection. If the bulb is in good condition, the level indicator switch may be faulty, replace the indicator switch with a new one.
- Remove the fuel level indicator switch from the fuel tank.
- Connect 12V battery to the fuel level indicator switch and ground through a 3.4W bulb. The bulb should light up after several seconds if the switch is in good condition.
- When the switch is immersed in water under the above condition, the bulb should go out. If the bulb remains lit, replace the fuel level indicator switch.

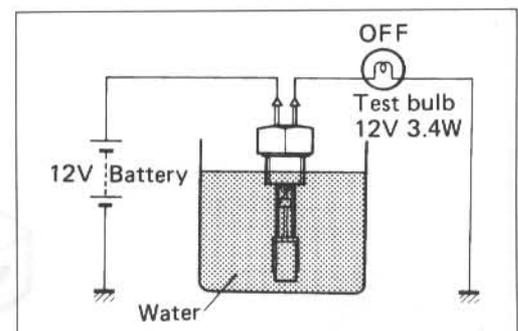
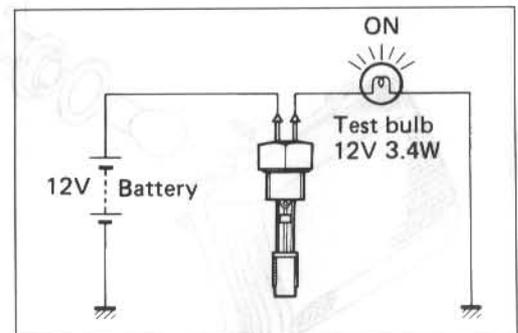
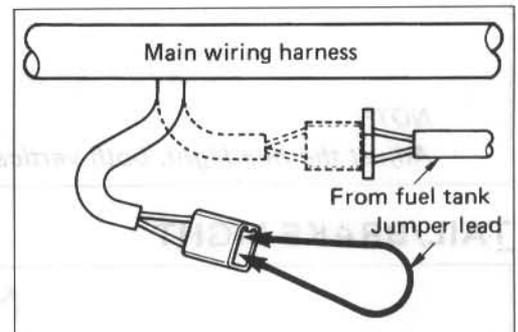

## LAMPS HEADLIGHT

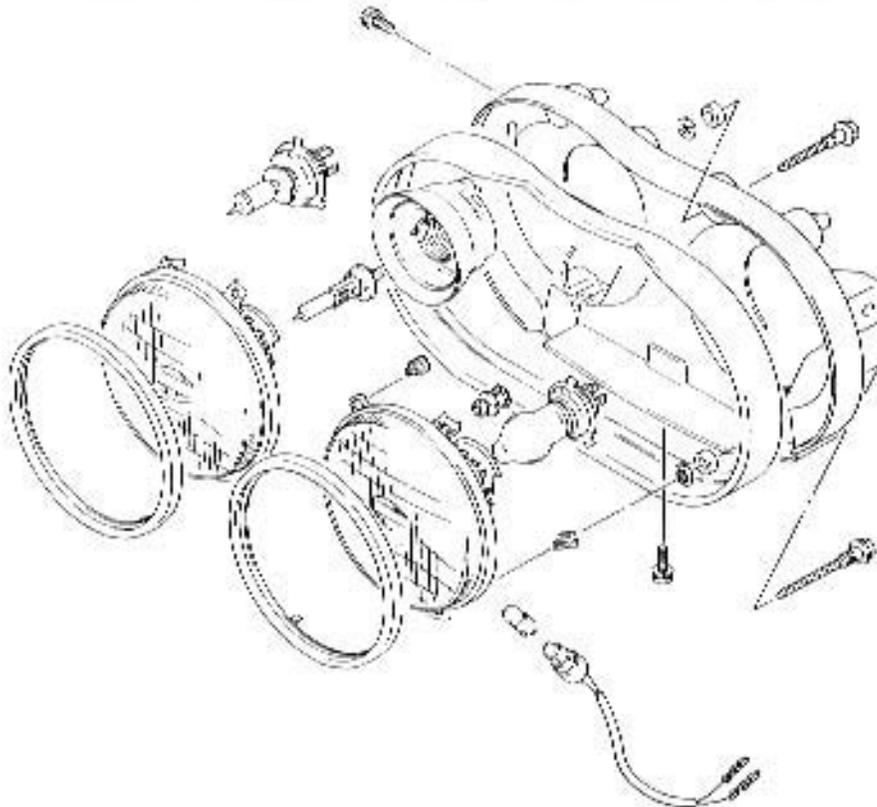

**NOTE:**

*Adjust the headlight, both vertical and horizontal, after reassembling.*

## TAIL/BRAKE LIGHT

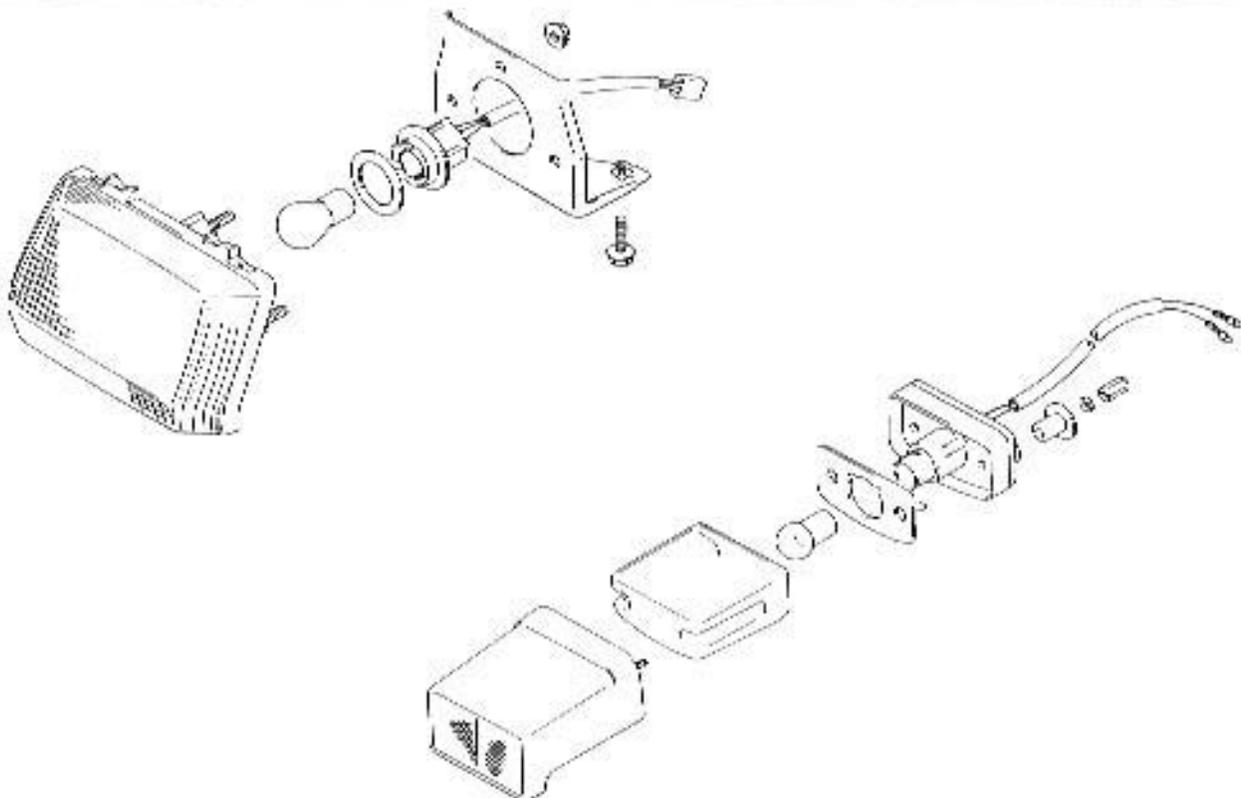



## TURN SIGNAL LIGHT

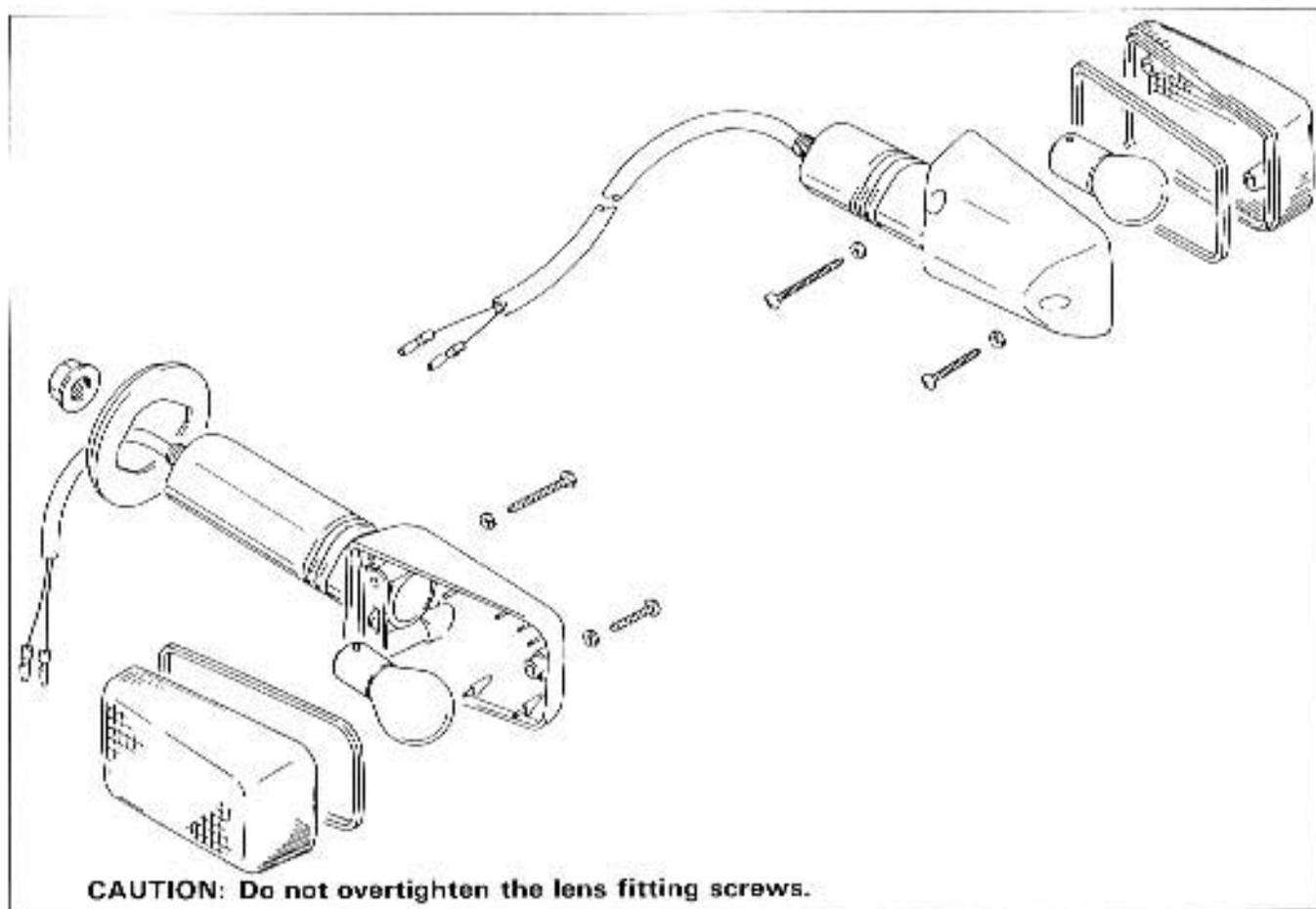

## SWITCHES

Inspect each switch for continuity with the pocket tester referring to the WIRING DIAGRAM. If any abnormality is found, replace the respective switch assemblies with new ones. (Refer to the chapter 7 of wiring diagram.)

### 09900-25002: Pocket tester

Tester knob indication:  $\times 1\Omega$  range

## OIL PRESSURE SWITCH

- Continuity, when engine is stopped.
- No continuity, when engine is running.

	G/Y	Ground
ON	○	○
OFF		

### NOTE:

Before inspecting the oil pressure switch, check if the engine oil level is enough.

## RELAY

### STARTER RELAY

The starter relay is located under the battery holder. (Refer to page 5-18 for details.)

### SIDE-STAND RELAY

The side-stand relay is located under the battery holder. (Refer to page 5-21 for details.)

### HEADLIGHT RELAY

(Except for Switzerland and Italy models)

The headlight relay is located on the fairing brace.

### INSPECTION

#### First:

Check the insulation between (1) and (2) terminals with pocket tester.

#### Second:

Apply DC 12 volts to (3) and (4) terminals, ⊖ to (3) and ⊖ to (4), and check the continuity between (1) and (2) with a pocket tester. If there is no continuity, replace it with a new one.

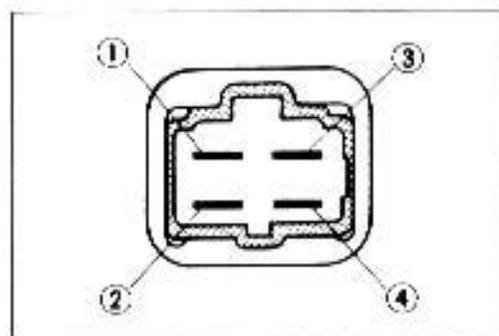

**09900-25002: Pocket tester**

Tester knob indication: × 1Ω range

### TURN SIGNAL RELAY

The turn signal relay is located on the fairing brace.

If the turn signal light does not light. Inspect the bulb or repair the circuit connection.

If the bulb and circuit connection checked are correct, the turn signal relay may be faulty, replace it with a new one.

#### NOTE:

*Be sure that the battery used is in a fully-charged condition.*

## BATTERY

### SPECIFICATIONS

Type designation	YB14L-A2
Capacity	12V, 50.4 kC (14 Ah)/10HR
Standard electrolyte S.G.	1.28 at 20°C (68°F)

In fitting the battery to the motorcycle, connect the breather hose to the battery vent.

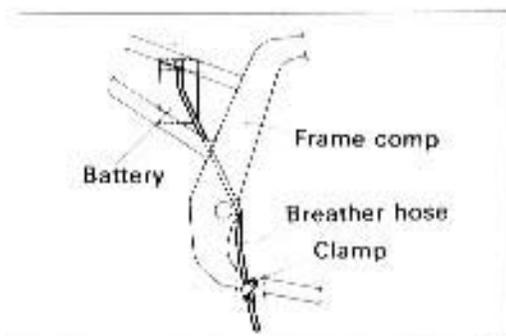

### INITIAL CHARGING

#### FILLING ELECTROLYTE

Remove the short sealed tube (A) before filling electrolyte. Fill the battery with electrolyte (dilute sulfuric acid solution with acid concentration of 35.0% by weight, having a specific gravity of 1.28 at 20°C (68°F)) up to indicated MAX.LEVEL. Electrolyte should be always cooled below 30°C (86°F) before filling into battery. Leave battery standing for half an hour after filling. Add additional electrolyte if necessary. Charge battery with current as described in the table shown below.

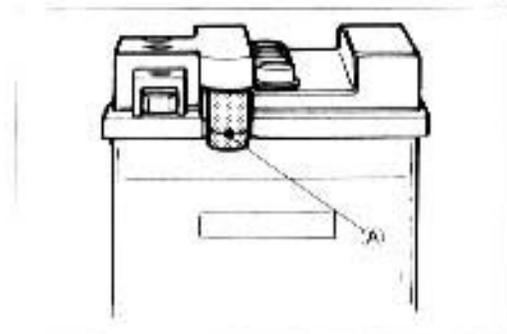

Maximum charging current	1.4A
--------------------------	------

#### CHARGING TIME

The charging time for a new battery is determined by the number of months that have elapsed since the date of manufacture.

#### CONFIRMATION FOR DATE OF MANUFACTURE

Date of manufacture is indicated by a three-part number (1), as shown in the photograph, each indicating month, date and year.

Near the end of charging period, adjust the specific gravity of electrolyte to value specified. After charging, adjust the electrolyte level to the MAX. LEVEL with DISTILLED WATER.



### SERVICING

Visually inspect the surface of the battery container. If any signs of cracking or electrolyte leakage from the sides of the battery have occurred, replace the battery with a new one. If the battery terminals are found to be coated with rust or an acidic white powdery substance, then this can be cleaned with sandpaper.

Check the electrolyte level and add distilled water, as necessary to raise the electrolyte to each cell's MAX. level. Check the battery for proper charge by taking an electrolyte S.G. reading. If the reading is 1.22 or less, as corrected to 20°C (68°F), it means that the battery is still in a run-down condition and needs recharging.

**NOTE:**

First, remove the  $\ominus$  lead wire.

Months after manufacturing	Within 6	Within 9	Within 12	Over 12
Necessary charging hours	20	30	40	60

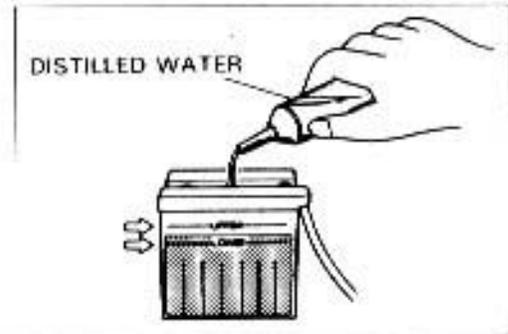

**RECHARGING OPERATION BASED ON S.G. READING**

To read the S.G. on the hydrometer, bring the electrolyte in the hydrometer to eye level and read the graduation on the float scale bordering on the meniscus (curved-up portion of electrolyte surface), as shown in figure.

**09900-28403: Hydrometer**

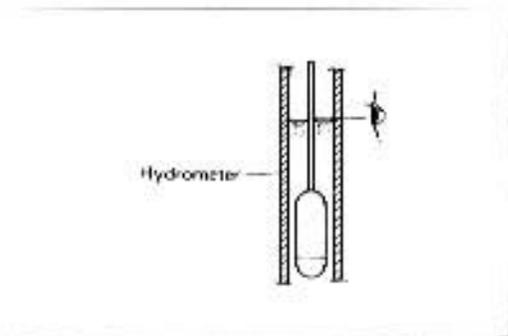

Check the reading (as corrected to 20°C) with chart to determine the recharging time in hour by constant-current charging at a charging rate of 1.4 amperes (which is tenth of the capacity of the present battery).

Electrolyte specific gravity	1.28 at 20°C (68°F)
------------------------------	---------------------

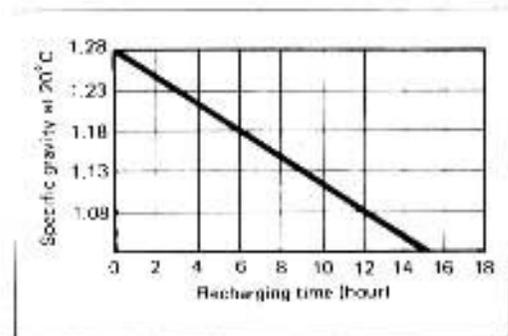

Be careful not to permit the electrolyte temperature to exceed 45°C (113°F), at any time, during the recharging operation. Interrupt the operation, as necessary, to let the electrolyte cool down. Recharge the battery to the specification.

**CAUTION:**

Constant-voltage charging, otherwise called "quick" charging, is not recommendable for it could shorten the life of the battery.

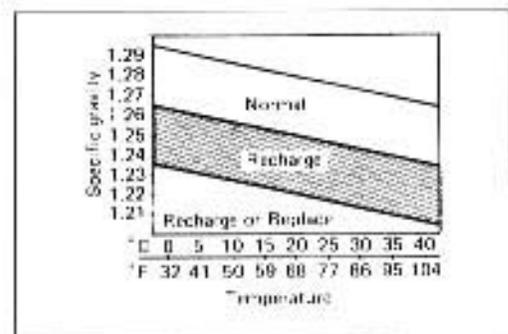

## SERVICE LIFE

Lead oxide is applied to the pole plates of the battery which will come off gradually during the service. When the bottom of the battery case becomes full of the sediment, the battery cannot be used any more. If the battery is not charged for a long time, lead sulfate is generated on the surface of the pole plates and will deteriorate the performance (sulfation). Replace the battery with new one in such a case. When a battery is left for a long term without use, it is apt to be subject to sulfation. when the motorcycle is not used for more than 1 month (especially during the winter season), recharge the battery once a month at least.

### WARNING:

- **Before charging a battery, remove the seal cap from each cell.**
- **Keep fire and sparks away from a battery being charged.**
- **When removing a battery from the motorcycle, be sure to remove the  $\ominus$  terminal first.**

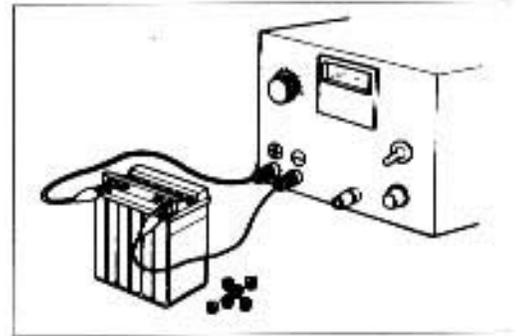

# CHASSIS

## CONTENTS

<b>FAIRING</b> .....	6- 1
<b>REMOVAL</b> .....	6- 1
<b>REMOUNTING</b> .....	6- 1
<b>FRONT WHEEL</b> .....	6- 2
<b>REMOVAL</b> .....	6- 2
<b>INSPECTION AND DISASSEMBLY</b> .....	6- 3
<b>REASSEMBLY AND REMOUNTING</b> .....	6- 4
<b>FRONT BRAKE</b> .....	6- 6
<b>BRAKE PAD REPLACEMENT</b> .....	6- 7
<b>CALIPER REMOVAL AND DISASSEMBLY</b> .....	6- 7
<b>CALIPER AND DISC INSPECTION</b> .....	6- 8
<b>CALIPER REASSEMBLY AND REMOUNTING</b> .....	6- 8
<b>MASTER CYLINDER REMOVAL AND DISASSEMBLY</b> .....	6- 9
<b>MASTER CYLINDER INSPECTION</b> .....	6-10
<b>MASTER CYLINDER REASSEMBLY AND REMOUNTING</b> .....	6-10
<b>FRONT FORK</b> .....	6-11
<b>REMOVAL</b> .....	6-11
<b>DISASSEMBLY</b> .....	6-12
<b>INSPECTION</b> .....	6-13
<b>REASSEMBLY AND REMOUNTING</b> .....	6-14
<b>STEERING</b> .....	6-17
<b>REMOVAL</b> .....	6-18
<b>DISASSEMBLY</b> .....	6-18
<b>INSPECTION</b> .....	6-18
<b>REASSEMBLY AND REMOUNTING</b> .....	6-19
<b>STEERING TENSION ADJUSTMENT</b> .....	6-21
<b>IGNITION SWITCH</b> .....	6-22
<b>REAR BRAKE</b> .....	6-23
<b>BRAKE PAD REPLACEMENT</b> .....	6-24
<b>CALIPER REMOVAL AND DISASSEMBLY</b> .....	6-24
<b>CALIPER AND DISC INSPECTION</b> .....	6-25
<b>CALIPER REASSEMBLY AND REMOUNTING</b> .....	6-25
<b>MASTER CYLINDER REMOVAL AND DISASSEMBLY</b> .....	6-26
<b>MASTER CYLINDER INSPECTION</b> .....	6-27
<b>MASTER CYLINDER REASSEMBLY AND REMOUNTING</b> .....	6-27
<b>REAR WHEEL</b> .....	6-28
<b>REMOVAL</b> .....	6-29
<b>INSPECTION AND DISASSEMBLY</b> .....	6-30
<b>REASSEMBLY AND REMOUNTING</b> .....	6-31
<b>TIRE AND WHEEL</b> .....	6-34
<b>TIRE REMOVAL</b> .....	6-34
<b>INSPECTION</b> .....	6-36
<b>TIRE MOUNTING</b> .....	6-37
<b>REAR SUSPENSION</b> .....	6-39
<b>SWINGARM</b> .....	6-39
<b>SHOCK ABSORBER AND CUSHION LEVER</b> .....	6-40
<b>REMOVAL</b> .....	6-41
<b>INSPECTION</b> .....	6-41
<b>DISASSEMBLY</b> .....	6-42
<b>REASSEMBLY INFORMATION</b> .....	6-44
<b>REASSEMBLY AND REMOUNTING</b> .....	6-45
<b>FINAL INSPECTION AND ADJUSTMENT</b> .....	6-45
<b>SUSPENSION SETTING</b> .....	6-46
<b>CLUTCH MASTER CYLINDER</b> .....	6-47

## FAIRING

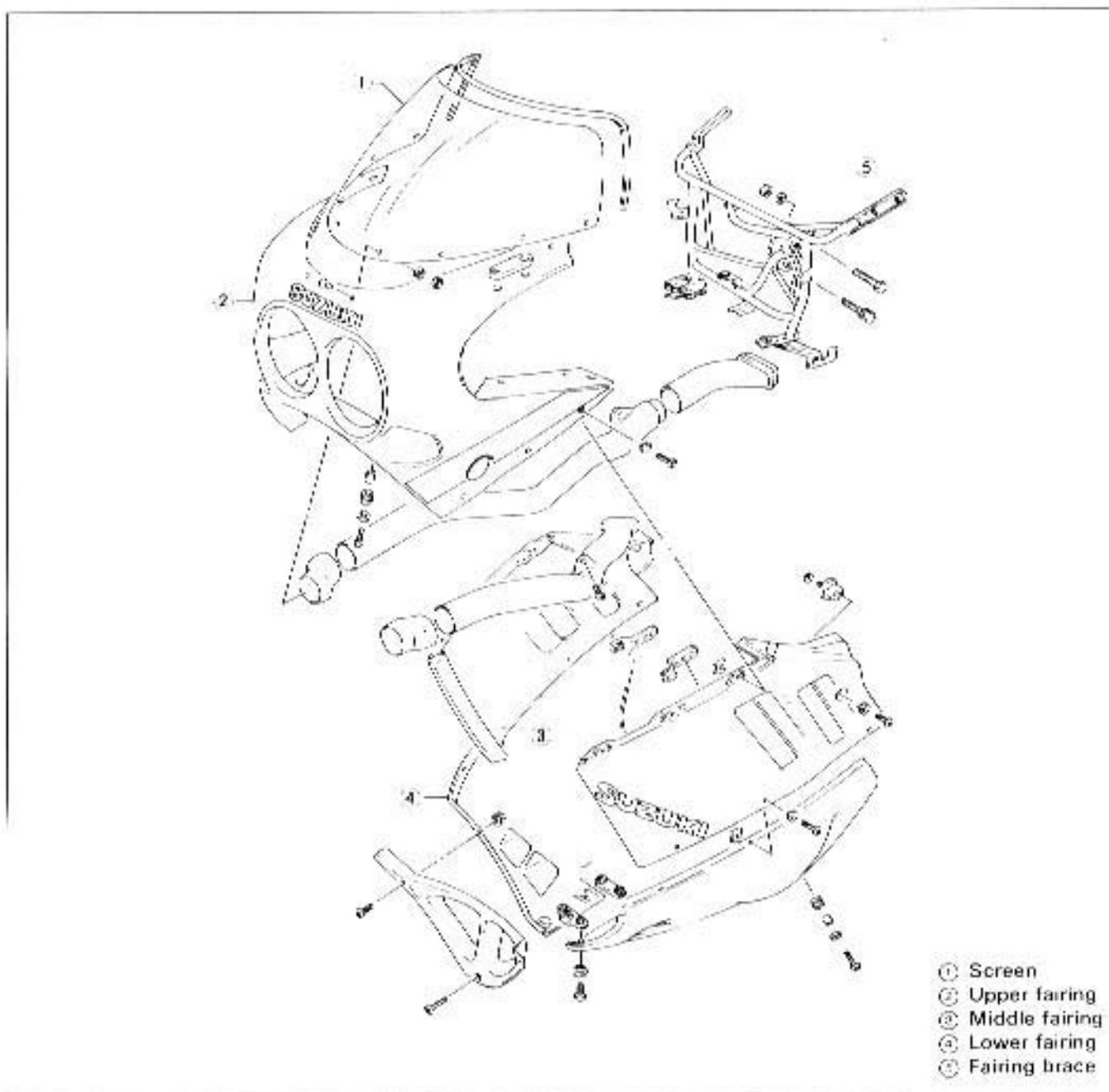

## REMOVAL

1. Remove the lower fairing assembly.
2. Remove the middle fairings.
3. Disconnect the front turn signal light lead wires, remove both front turn signal lights.
4. Remove both rear view mirrors.
5. Remove the upper fairing assembly.

**09900-00401: L-type hexagon wrench**

## REMOUNTING

Remount the fairings in the reverse order of removal.

## FRONT WHEEL

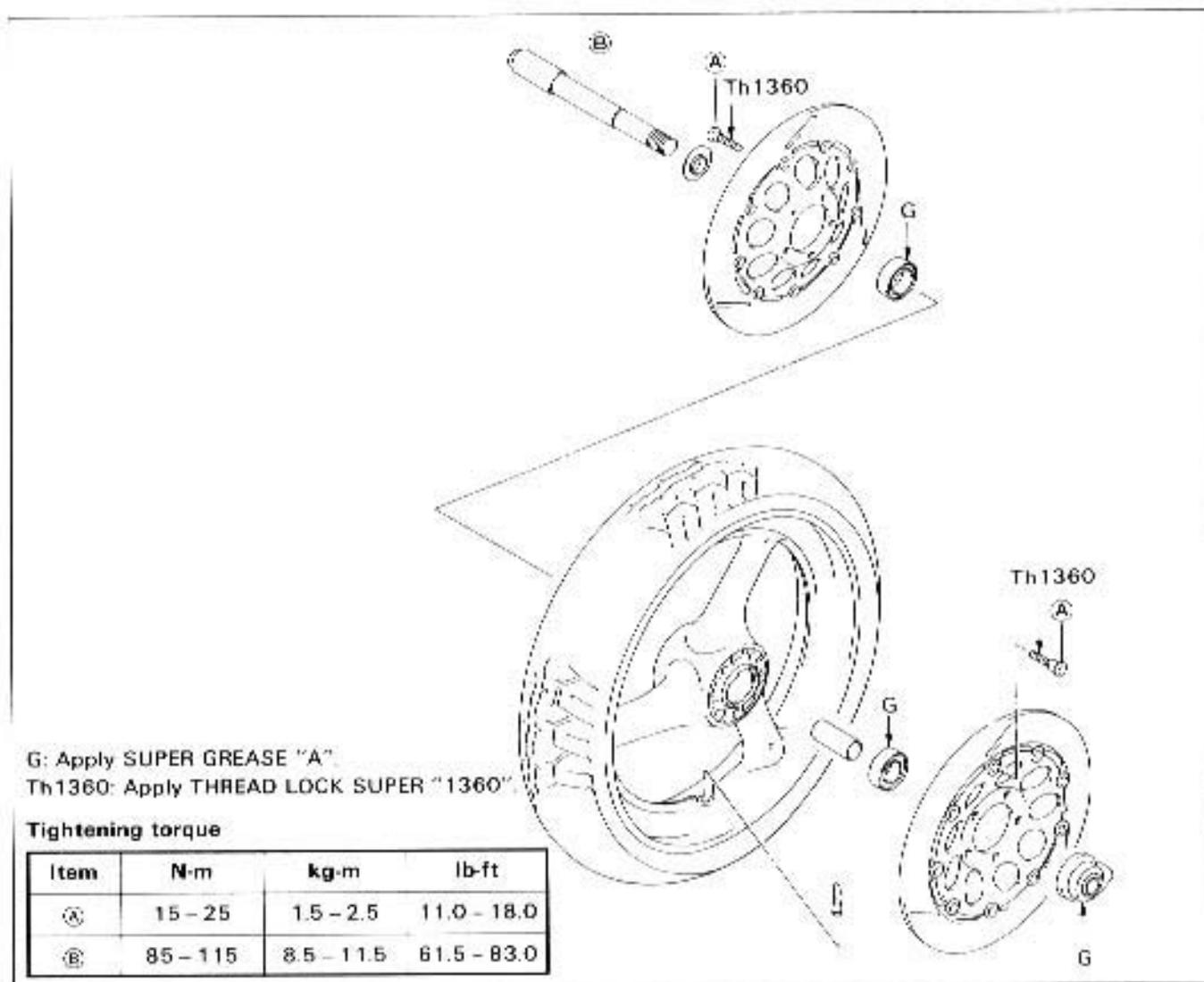

## REMOVAL

1. Remove the lower fairing assembly.
2. Support the motorcycle with a jack or wooden block.
3. Loosen the axle pinch bolts.
4. Loosen the axle shaft.
5. Remove both brake calipers.
6. Remove the axle shaft and front wheel.

## CAUTION:

- \* Do not operate the brake lever while dismantling the brake calipers.
- \* Hang the brake caliper on the motorcycle frame with a string etc., taking care not to bend the brake hose.

7. Remove both brake discs off the front wheel by removing the mounting bolts.

09900-00410: Hexagon wrench set  
(Not available in U.S.A)



## INSPECTION AND DISASSEMBLY SPEEDOMETER GEAR BOX DUST SEAL

Inspect the lip of dust seal for damage.

### TIRE

Refer to page 6-34.

### WHEEL BEARINGS

Inspect the play of the wheel bearings by hand while they are in the wheel. Rotate the inner race by hand to inspect for abnormal noise and smooth rotation. Replace the bearing if there is anything unusual.

### AXLE SHAFT

Using a dial gauge, check the axle shaft for runout and replace it if the runout exceeds the limit.

09900-20606: Dial gauge (1/100)

09900-20701: Magnetic stand

09900-21304: V-block set (100 mm)

Not available  
in U.S.A.

Service limit: 0.25 mm (0.010 in)

### WHEEL

Make sure that the wheel runout checked as shown does not exceed the service limit. An excessive runout is usually due to worn or loosen wheel bearings and can be reduced by replacing the bearings. If bearing replacement fails to reduce the runout, replace the wheel.

Service limit (Axial and Radial): 2.0 mm (0.08 in)

- Drive out both wheel bearings by using the special tool in the following procedures.

09941-50110: Bearing remover

(Not available in U.S.A.)

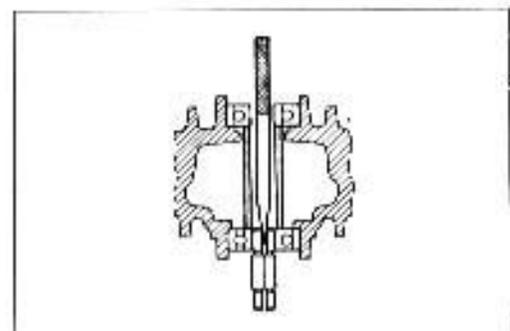
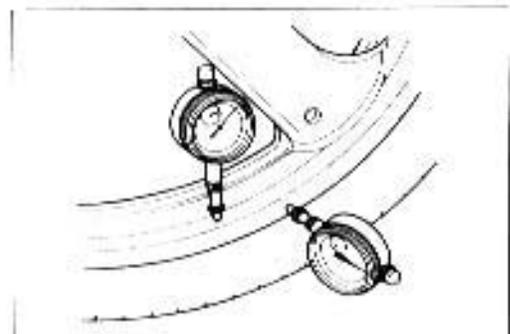
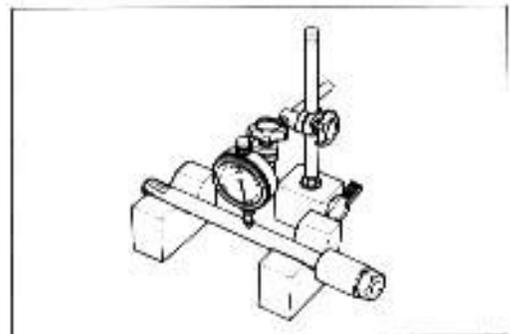
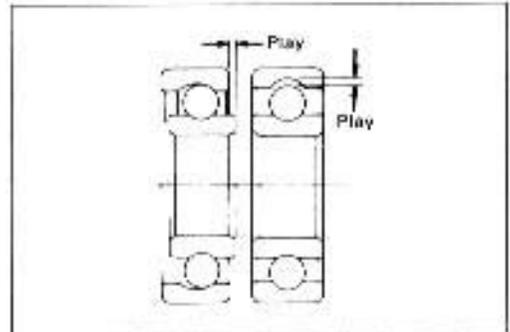
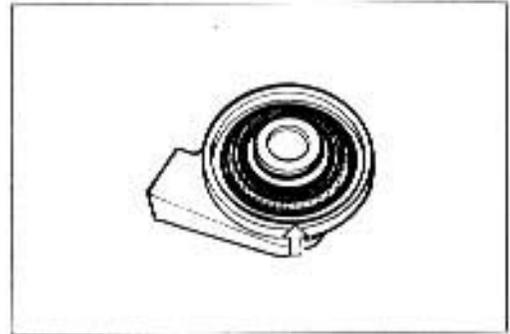

- Insert the adaptor into the wheel bearing.
- After inserting the wedge bar from the opposite side, lock the wedge bar in the slit of the adaptor.
- Drive out the wheel bearing by knocking the wedge bar.

**CAUTION:**

The removed bearings should be replaced with new ones.

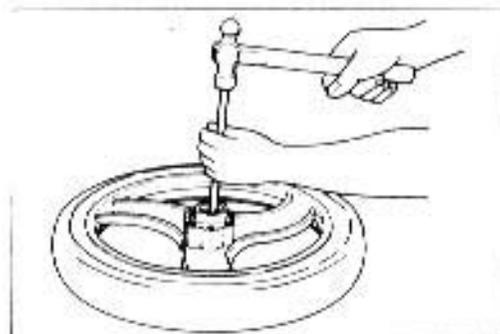
**REASSEMBLY AND REMOUNTING**

Reassemble and remount the front wheel in the reverse order of removal and disassembly. Pay attention to the following points:

**WHEEL BEARING**

- Apply grease to the bearing before installing.

(For U.S.A. model)

**99000-25030: SUZUKI SUPER GREASE "A"**

(For the other models)

**99000-25010: SUZUKI SUPER GREASE "A"**

- Install the wheel bearings as follows by using the special tool.

**09924-84510: Bearing installer set**

**NOTE:**

First install the left wheel bearing, then install the right wheel bearing. The sealed cover on the bearing is positioned out side.

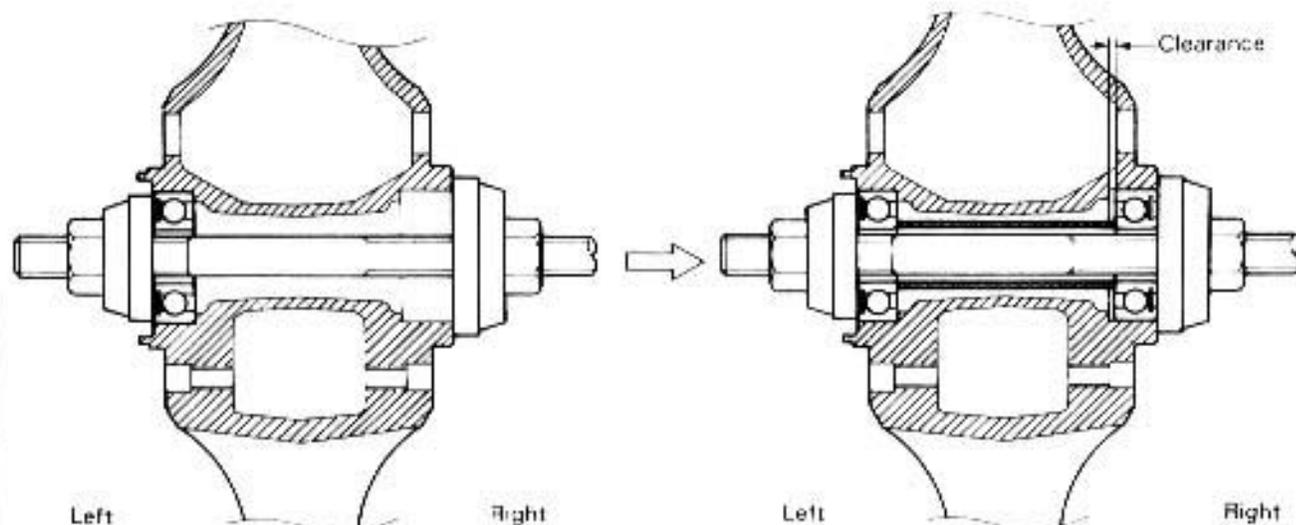
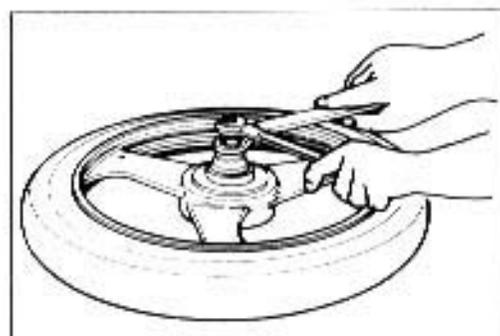

**BRAKE DISC**

- Make sure that the brake disc is clean and free of any greasy matter. Apply **THREAD LOCK SUPER "1360"** to the disc mounting bolts and tighten them to the specified torque.

**Tightening torque: 15 – 25 N·m**

**[1.5 – 2.5 kg·m, 11.0 – 18.0 lb-ft]**

**99000-32130: THREAD LOCK SUPER "1360"**

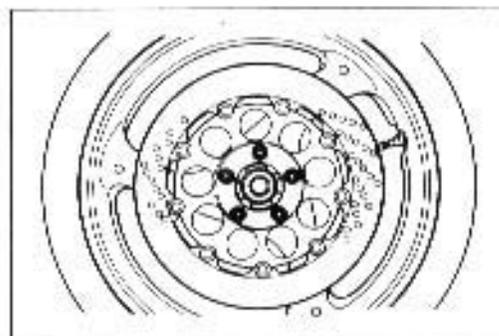
**SPEEDOMETER GEARBOX**

- Before installing the speedometer gearbox, apply grease to its dust seal lip and align the drive lugs ① to the recesses ② of the wheel hub and attach the speedometer gearbox to the wheel hub.

**(For U.S.A. model)**

**99000-25030: SUZUKI SUPER GREASE "A"**

**(For the other models)**

**99000-25010: SUZUKI SUPER GREASE "A"**

- Set the stopper on the speedometer gearbox to the lug ③ on the left front fork.

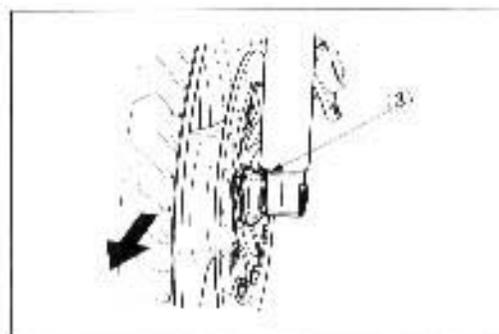
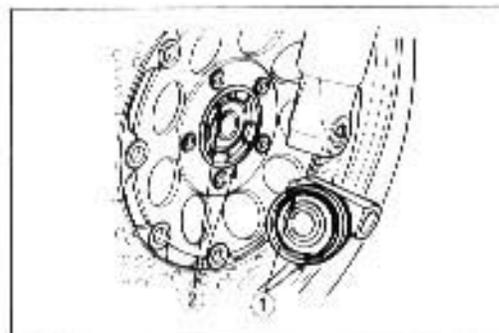
**BRAKE CALIPER**

- Tighten the brake caliper mounting bolts to the specified torque.

**Tightening torque: 27 – 43 N·m**

**(2.7 – 4.3 kg·m, 19.5 – 31.0 lb-ft)**

**NOTE:**

*Push the pistons all the way into the caliper and remount the calipers.*

**AXLE SHAFT**

- Tighten the axle shaft to the specified torque.

**Tightening torque: 85 – 115 N·m**

**(8.5 – 11.5 kg·m, 61.5 – 83.0 lb-ft)**

- Tighten the pinch bolts to the specified torque.

**Tightening torque: 18 – 28 N·m**

**(1.8 – 2.8 kg·m, 13.0 – 20.0 lb-ft)**

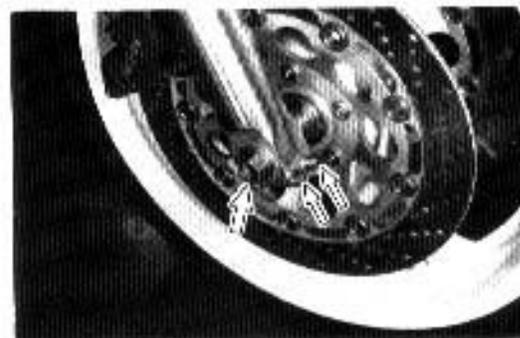
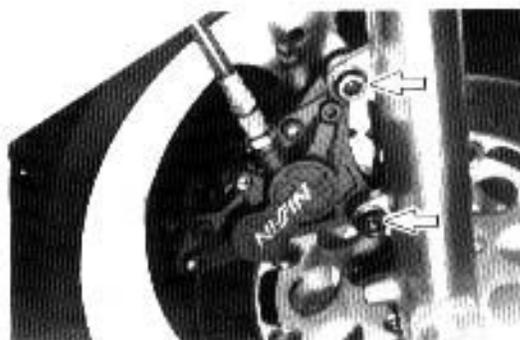



## BRAKE PAD REPLACEMENT

1. Remove the pads mounting bolt.
2. Remove the pads.  
**09900-00410: Hexagon wrench set**  
**(Not available in U.S.A.)**

### CAUTION:

- \* Do not operate the brake lever while dismounting the pads.
- \* Replace the brake pad as a set, otherwise braking performance will be adversely affected.

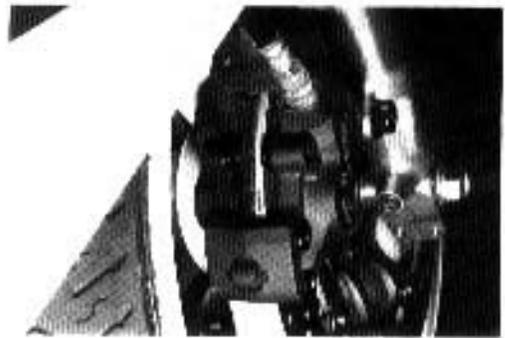

## CALIPER REMOVAL AND DISASSEMBLY

1. Disconnect the brake hose and catch brake fluid in a suitable receptacle.

### CAUTION:

Never re-use the brake fluid left over from previous servicing and stored for long periods.

### WARNING:

Brake fluid, if it leaks, will interfere with safe running and discolor painted surfaces. Check the brake hose and hose joint for cracks and oil leakage.

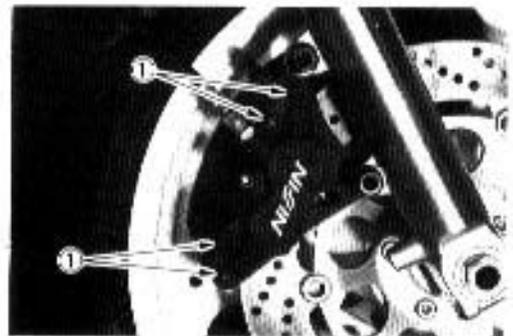

2. Remove the caliper.

### NOTE:

Slightly loosen the caliper housing bolts ① to facilitate later disassembly before removing the caliper mounting bolts.

3. Remove the pads.
4. Separate the caliper halves to remove the caliper housing bolts.
5. Remove the O-rings.

### NOTE:

Once separate the caliper halves, replace the O-rings with new ones.

6. Place a rag over the pistons to prevent them from popping out and push out the pistons by using an air gun.

### CAUTION:

Do not use high pressure air to prevent piston damage.

7. Remove the piston, dust seal and piston seal out of the caliper.

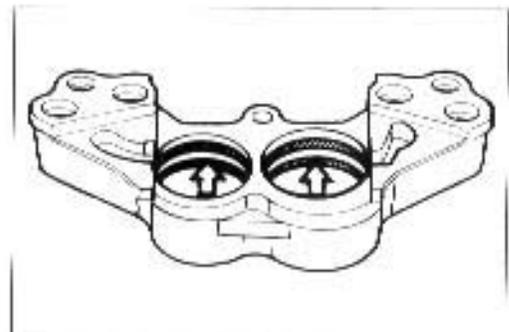

## CALIPER AND DISC INSPECTION

### CALIPER

Inspect the caliper bore wall for nicks, scratches or other damage.

### PISTON

Inspect the piston surface for any scratches or other damage.

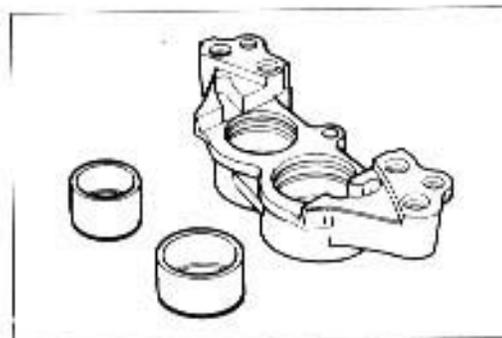

### RUBBER PARTS

Inspect each rubber part for damage and wear.

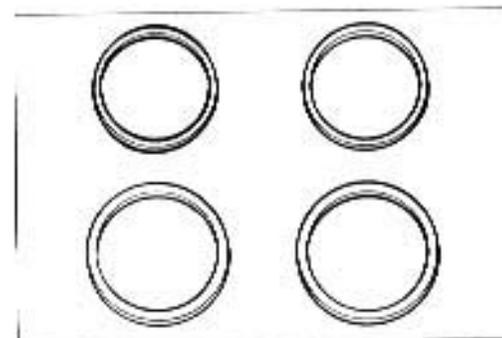

### DISC

Using a micrometer, check the disc for wear, its thickness can be checked with disc and wheel in place. The service limits for the thickness of the discs are shown below.

**09900-20205: Micrometer (0 – 25 mm)**

**Service limit (Front): 4.5 mm (0.18 in)**

**(Rear): 5.5 mm (0.22 in)**

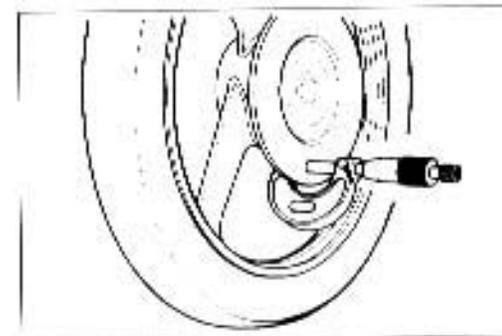

With the disc mounted on the wheel, check the disc for face runout with a dial gauge, as shown.

**09900-20606: Dial gauge (1/100 mm)**

**09900-20701: Magnetic stand (Not available in U.S.A.)**

**Service limit: 0.30 mm**

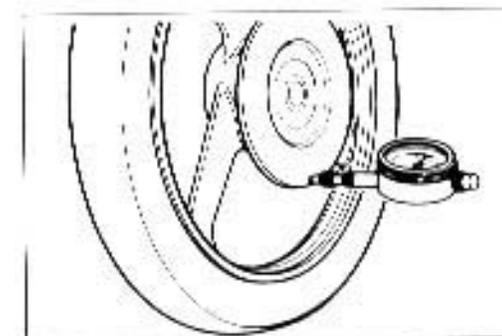

## CALIPER REASSEMBLY AND REMOUNTING

Reassemble and remount the caliper in the reverse order of removal and disassembly. Pay attention to the following points:

### CAUTION:

- \* Wash the caliper components with fresh brake fluid before reassembly.
- \* Never use cleaning solvent or gasoline to wash them.
- \* Apply brake fluid to the caliper bore and piston to be inserted into the bore.



**CALIPER BOLTS**

Tighten each bolt to the specified torque.

**Tightening torque:**

- (1) 20 - 25 N-m (2.0 - 2.5 kg-m, 14.5 - 18.0 lb-ft)
- (2) 27 - 43 N-m (2.7 - 4.3 kg-m, 19.5 - 31.0 lb-ft)
- (3) 20 - 25 N-m (2.0 - 2.5 kg-m, 14.5 - 18.0 lb-ft)

**CAUTION:**

Bleed air from the system after reassembling the caliper.  
(Refer to page 2-14.)

**MASTER CYLINDER REMOVAL AND DISASSEMBLY**

1. Remove the front brake light switch lead wires.
2. Place a rag underneath the union bolt on the master cylinder to catch any spilled drops of brake fluid. Remove the union bolt and disconnect the brake hose/master cylinder joint.

**CAUTION:**

Completely wipe off any brake fluid adhering to any parts of motorcycle. The fluid reacts chemically with paint, plastics, rubber materials, etc.

3. Remove the master cylinder assembly.
4. Remove the front brake lever, reservoir cap and diaphragm.
5. Drain brake fluid.
6. Remove the dust seal, then remove the circlip by using the special tool.

09900-06108: Snap ring pliers

- Remove the piston/secondary cup, primary cup and spring.
  - (1) Secondary cup
  - (2) Piston
  - (3) Primary cup
  - (4) Return spring

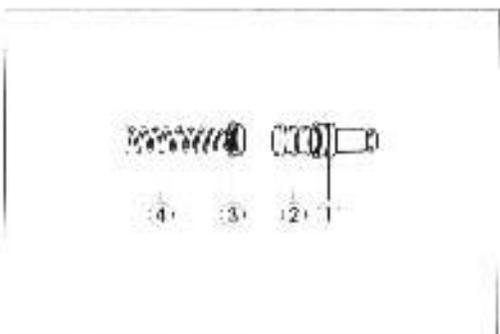
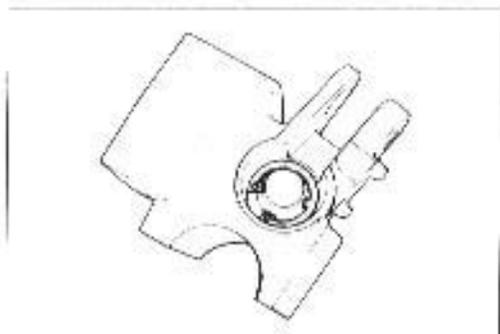
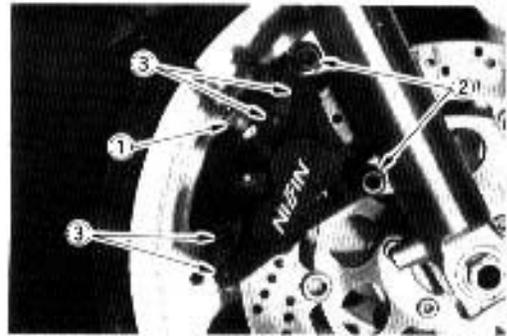

## MASTER CYLINDER INSPECTION

Inspect the master cylinder bore for any scratches or other damage.

Inspect the piston surface for any scratches or other damage.

Inspect the primary cup, secondary cup and dust seal for wear or damage.

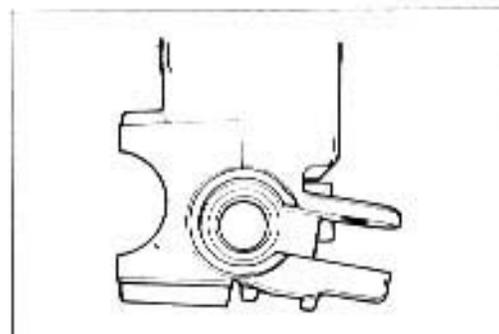

## MASTER CYLINDER REASSEMBLY AND REMOUNTING

Reassemble and remount the master cylinder in the reverse order of removal and disassembly. Pay attention to the following points:

### CAUTION:

Wash the master cylinder components with fresh brake fluid before reassembly. Never use cleaning solvent or gasoline to wash them. Apply brake fluid to the cylinder bore and all the internals to be inserted into the bore.

- When remounting the master cylinder on the handlebar, align the master cylinder holder mating surface (1) with punched mark (2) on the handlebar, and tighten the upper clamp bolt first as shown.

Tightening torque: 5.0 – 8.0 N-m  
(0.5 – 0.8 kg-m, 3.5 – 6.0 lb-ft)

### CAUTION:

Bleed air from the system after reassembling master cylinder. (Refer to page 2-14.)

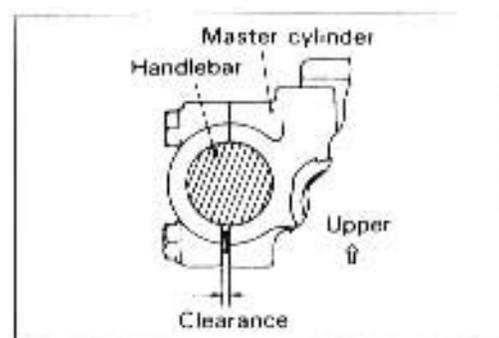
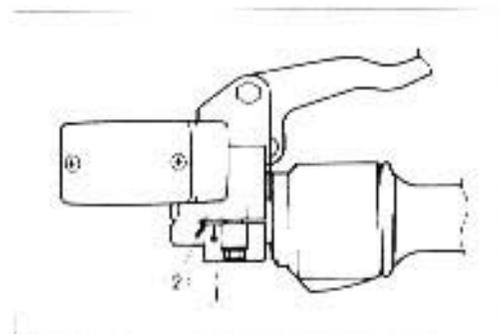
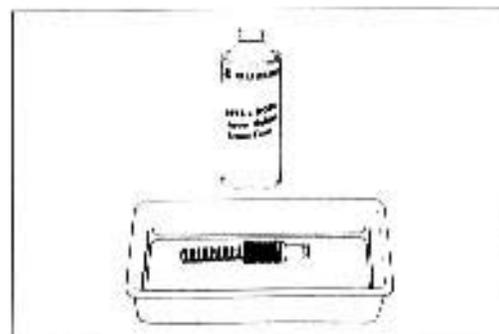



## FRONT FORK

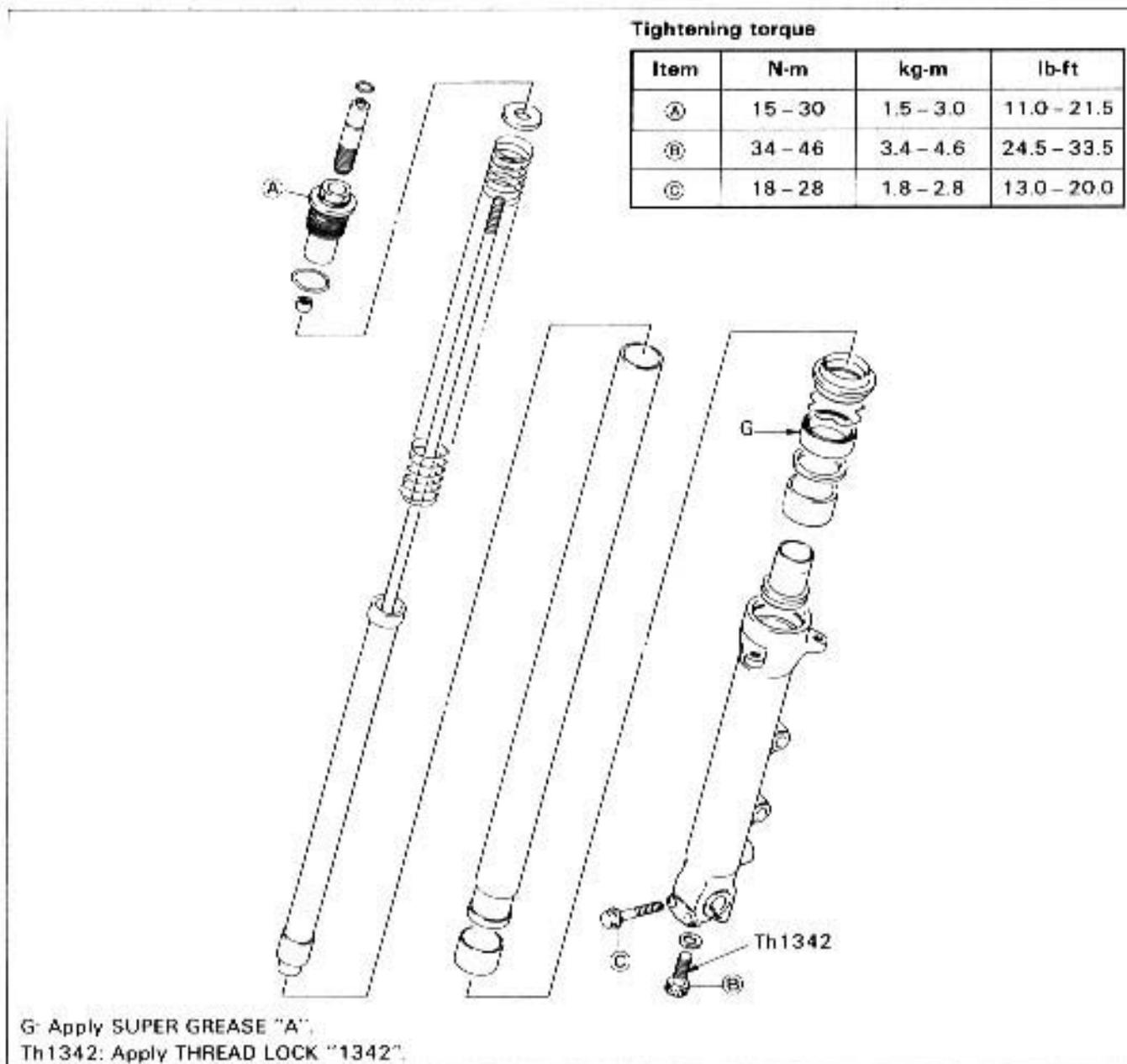

## REMOVAL

1. Remove the lower fairing assembly.
2. Support the motorcycle with a jack or wooden block.
3. Remove the front wheel.
4. Remove the front fender.
5. Remove the front fender brace.

**09900-00401: L-type hexagon wrench**

## NOTE:

*Slightly loosen the front fork cap to facilitate later disassembly before loosening the front fork clamp bolts. When removing the left front fork make sure to loosen the steering damper bracket bolt ①.*

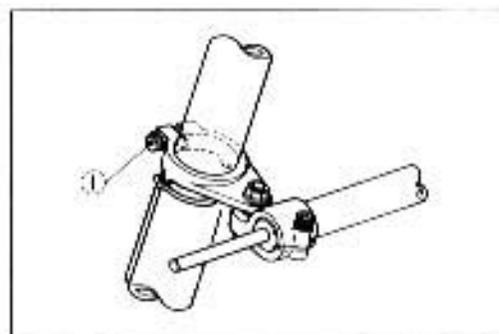

6. Loosen the handlebar holder mounting bolts and nuts.
7. Loosen the front fork upper and lower clamp bolts.
8. Remove the front forks.

**09900-00410: Hexagon wrench set**  
(Not available in U.S.A.)

## DISASSEMBLY

1. Push the inner tube down and loosen the spring adjuster lock nut, and remove the front fork cap, spring retainer and spring.

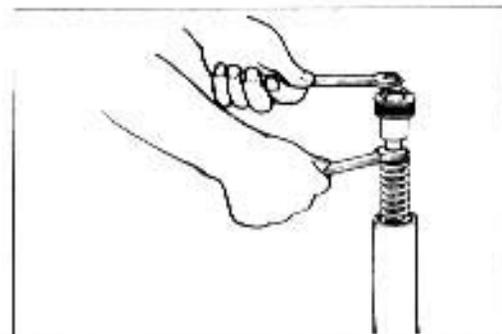

2. Invert the fork and stroke it several times to let out fork oil.
3. Under the inverted condition of front fork, drain oil to hold it for a few minutes.

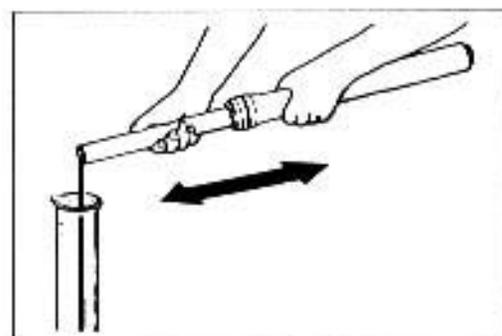

4. While holding the caliper mounting portion ① by vise and remove the damper rod bolt with the special tool and hexagon wrench.

**09940-54820: Front fork disassembling tool**  
**09900-00401: "L" type hexagon wrench set**

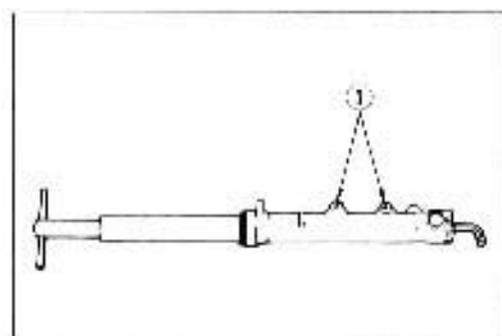

5. Remove the inner rod/damper rod out of the inner tube.

### CAUTION:

**Do not attempt to disassemble the inner rod/damper rod.**

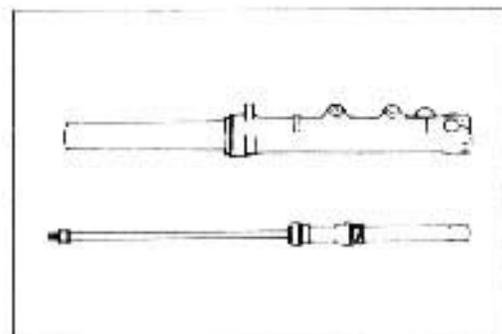

6. Remove the dust seal and oil seal stopper ring.

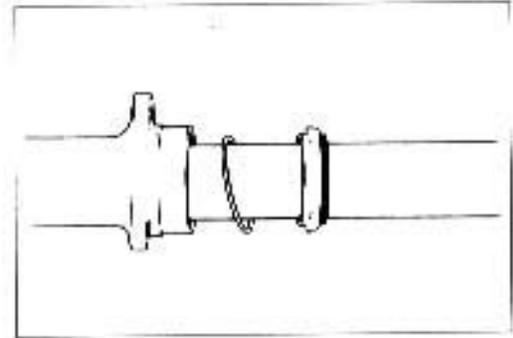

7. Separate the inner tube out of the outer tube.

*NOTE:*

*Be careful not to damage the inner tube.*

**CAUTION:**

**The outer tube and inner tube "ANTI-FRICTION" metals must be replaced along with the oil seal and dust seal, when assembling the front fork.**

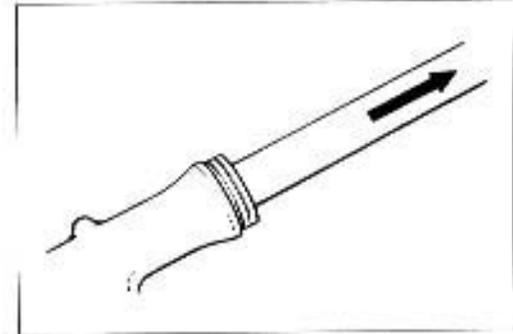

8. Turn in the spring adjuster and remove it from the front fork cap.

**CAUTION:**

**The O-ring removed should be replaced with a new one.**

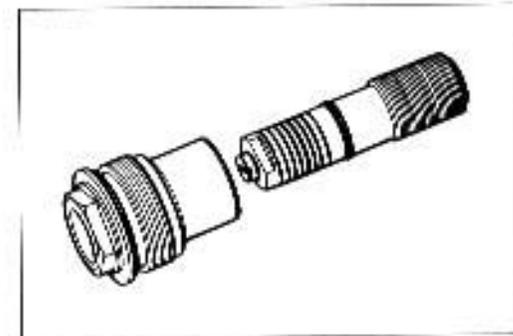

## INSPECTION DAMPER ROD

Inspect the damper rod for wear and damage.

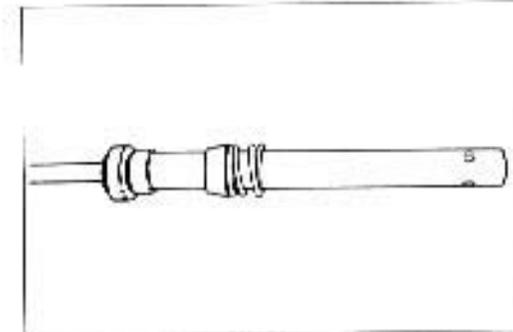

## INNER AND OUTER TUBE

Inspect the inner tube sliding surface and outer tube sliding surface for any scuffing.

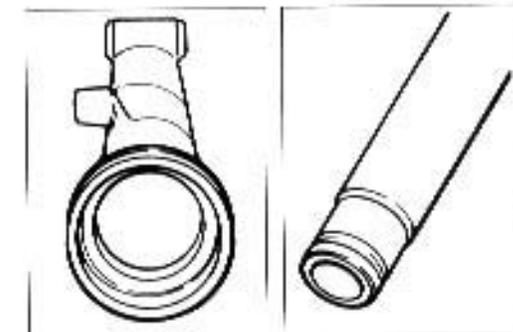

**FORK SPRING**

Measure the fork spring free length. If it is shorter than the service limit, replace it with a new one.

**Service limit: 347 mm (13.7 in)**

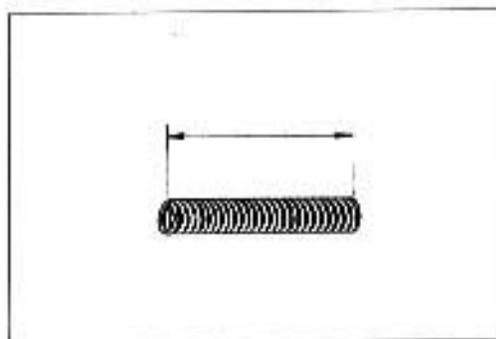
**REASSEMBLY AND REMOUNTING**

Reassemble and remount the front fork in the reverse order of removal and disassembly. Pay attention to the following points:

**INNER TUBE METAL**

- Hold the inner tube vertically and clean the metal groove and install the metal by hand as shown.

**CAUTION:**

Use special care to prevent damage to the "TEFLON" coated surface of the Anti-Friction metal when mounting it.

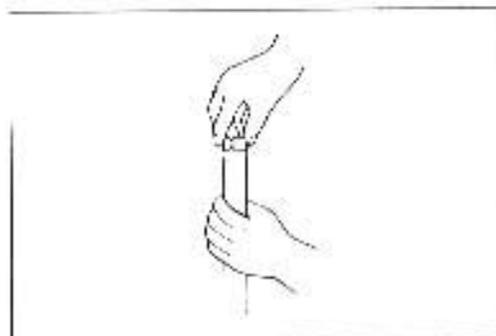
**DAMPER ROD BOLT**

- Apply THREAD LOCK "1342" to the damper rod bolt and tighten it to the specified torque with the special tool and hexagon wrench.

**99000-32050: THREAD LOCK "1342"**

Front fork damper: **34 – 46 N·m**  
rod bolt (3.4 – 4.6 kg·m, 24.5 – 33.5 lb·ft)

**09940-54820: Front fork assembler**

**09900-00401: "L" type hexagon wrench set**

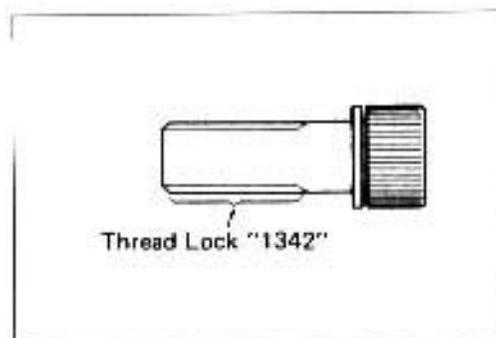
**OUTER TUBE METAL, OIL SEAL AND DUST SEAL**

- Clean the metal groove of outer tube and metal outer surface.
- Install the outer tube metal, oil seal retainer and oil seal.

**09940-50112: Front fork oil seal installer****CAUTION:**

Use special care to prevent damage to the "TEFLON" coated surface of the Anti-Friction outer tube metal when installing it.

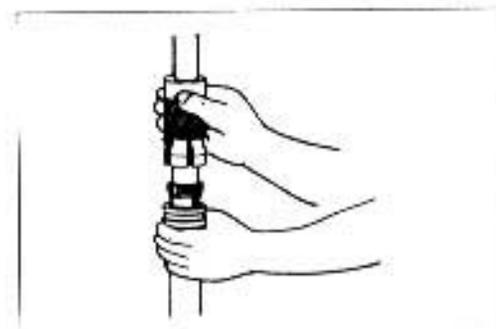

- After installing the oil seal, install the oil seal stopper ring and dust seal.

- (1) Anti-Friction metal
- (2) Oil seal retainer
- (3) Oil seal
- (4) Oil seal stopper ring
- (5) Dust seal

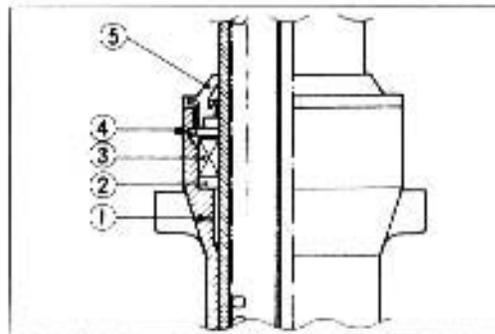

### FORK OIL

- Use front fork oil whose viscosity rating meets the specifications below.
- Fully stroke inner rod and inner tube to pump out air from cartridge and outer tube.

Fork oil type	Fork oil #5
Fork oil capacity (For U.S.A. model)	453 ml (15.3/16.0 US/Imp oz)
Fork oil capacity (For the other models)	418 ml (14.1/14.7 US/Imp oz)

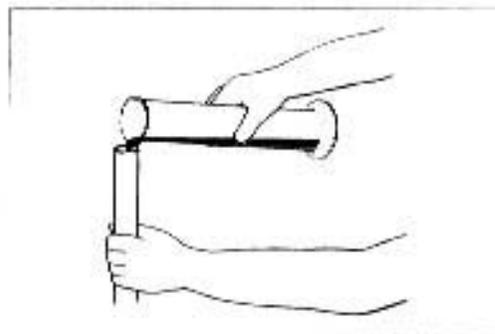

### 99000-99044-05G: SUZUKI FORK OIL #5

- Hold the front fork vertical and adjust fork oil level with the special tool.

#### NOTE:

When adjusting fork oil level, remove the fork spring and compress the inner tube fully.

### 09943-74111: Fork oil level gauge

		Standard
Front fork oil level	For U.S.A. model	113 mm (4.45 in)
	For the other models	146 mm (5.75 in)

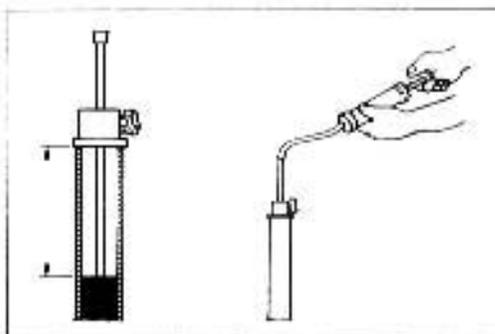

### REBOUND DAMPING FORCE ADJUSTER AND SPRING ADJUSTER

- Adjust the depth (A) to 25 mm from the bottom end of the spring adjuster (2) by turning the rebound damping force adjuster (1), and then install the spring adjuster (2) to the inner rod (3) as shown in the illustration.

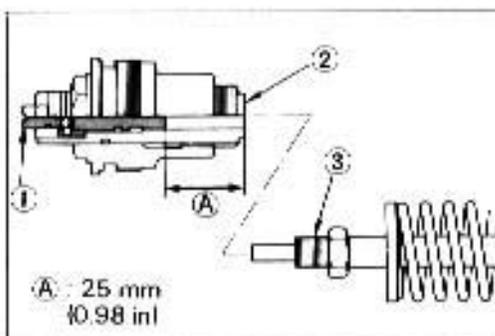

- Slowly turn in the spring adjuster ② by hand until it stops by finger tight.
- Holding the spring adjuster ② in this position, tighten the lock nut ④ to the specified torque.

#### Front fork spring

adjuster lock nut: **13.5 – 16.5 N·m**  
(1.35 – 1.65 kg·m, 10.0 – 12.0 lb·ft)



#### FRONT FORK CAP

- Install the front fork cap to the spring adjuster.
- Install the front fork cap to the inner tube and tighten it to the specified torque.

Front fork cap: **15 – 30 N·m**  
(1.5 – 3.0 kg·m, 11.0 – 21.5 lb·ft)



#### FRONT FORK REMOUNTING

- When remounting the front fork assembly, set the upper surface of the inner tube to 42.5 mm height above that of the steering stem upper bracket.

#### TIGHTENING TORQUE

- ① (Front fork upper clamp bolt):  
22 – 35 N·m (2.2 – 3.5 kg·m, 16.0 – 25.5 lb·ft)
- ② (Front fork lower clamp bolt):  
22 – 35 N·m (2.2 – 3.5 kg·m, 16.0 – 25.5 lb·ft)
- ③ (Handlebar holder mounting bolt):  
50 – 60 N·m (5.0 – 6.0 kg·m, 36.0 – 43.5 lb·ft)
- ④ (Handlebar holder mounting nut):  
22 – 35 N·m (2.2 – 3.5 kg·m, 16.0 – 25.5 lb·ft)

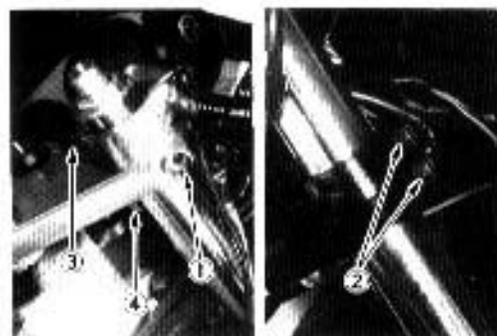
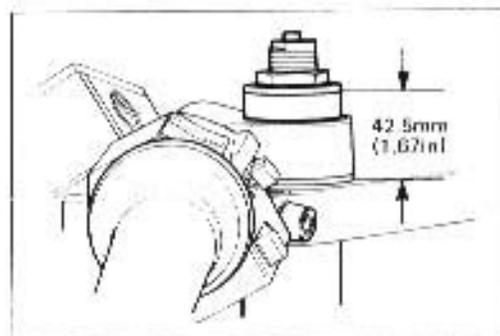

#### NOTE:

Before tightening the front fender brace mounting bolts and axle pinch bolts, move the front fork up and down 4 or 5 times.

Refer to the 6-20 for steering damper mounting procedure.



## STEERING

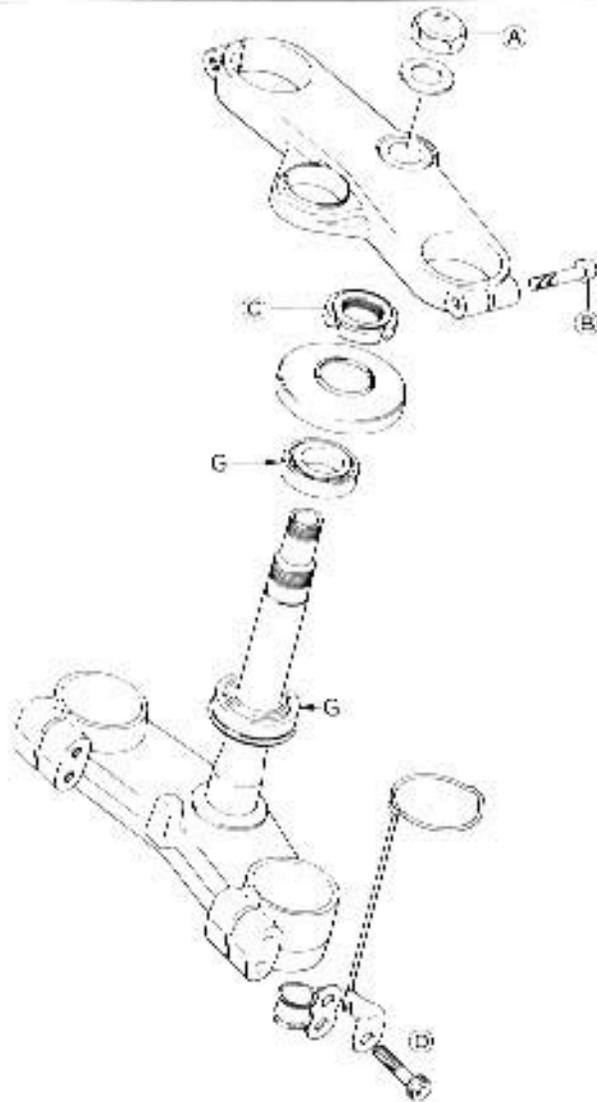

## Tightening torque

Item	N·m	kg·m	lb·ft
(A)	50 - 80	5.0 - 8.0	36.0 - 58.0
(B)	22 - 35	2.2 - 3.5	16.0 - 25.5
(C)	40 - 50	4.0 - 5.0	29.0 - 36.0
(D)	22 - 35	2.2 - 3.5	16.0 - 25.5

G: Apply SUPER GREASE "A".

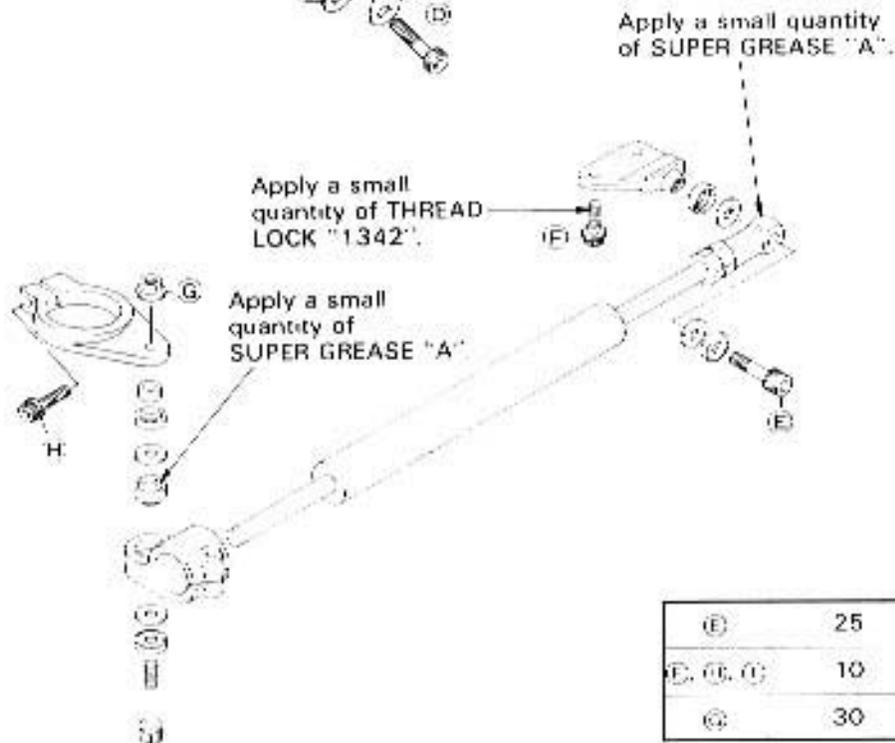

(E)	25	2.5	18.0
(F), (G), (H)	10	1.0	7.0
(G)	30	3.0	21.5

## REMOVAL

1. Remove the lower fairing assembly, middle fairings and upper fairing assembly.
2. Support the motorcycle with a jack or wooden block.
3. Remove the front wheel.
4. Remove the front forks and steering damper.
5. Remove the left and right handlebars by removing the handlebar holder mounting bolts and nuts.
6. Remove the speedometer/tachometer bracket mounting bolts.
7. Disconnect the meter lead wire coupler and remove the meter assembly.
8. Remove the steering stem head nut.
9. Remove the steering stem head by disconnecting the ignition switch lead wire coupler.
10. Remove the brake hose joint mounting bolt (1).
11. Remove the steering stem nut (2) by using the special tool, then remove the steering stem lower bracket.

### 09940-14911: Steering stem nut wrench

#### NOTE:

Hold the steering stem lower bracket by hand to prevent it from falling.

## DISASSEMBLY

1. Remove the steering stem upper bearing.
2. Remove the steering stem lower bearing by using the special tools.

### 09941-84510: Bearing remover

#### CAUTION:

The removed bearing should be replaced.

3. Drive out the steering stem bearing races, upper and lower, by using the appropriate drift.

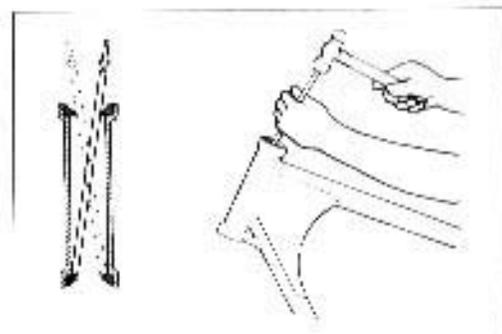
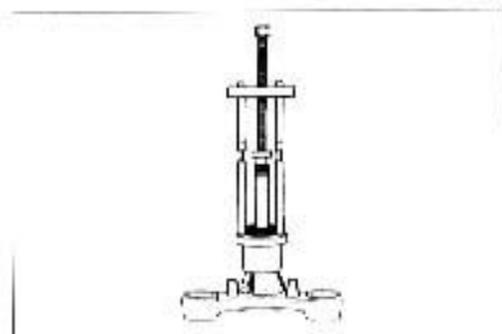
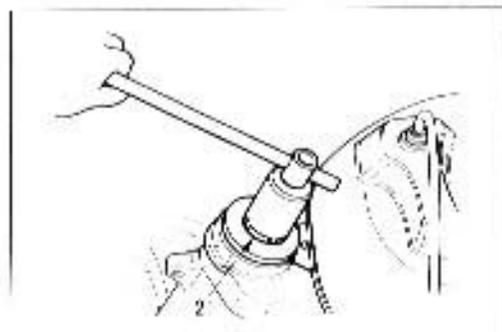
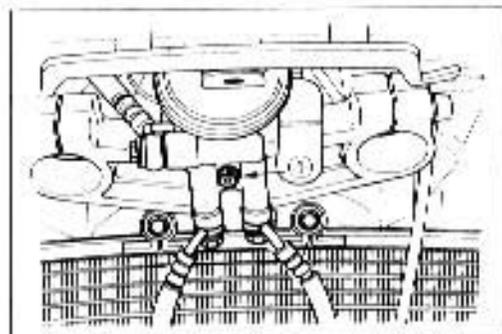

## INSPECTION

Inspect the removed parts for the following abnormalities.

- \* Handlebar distortion
- \* Race wear and brinelling
- \* Bearing wear or damage
- \* Abnormal noise of bearing
- \* Distortion of steering stem
- \* Oil leakage of steering damper
- \* Heavy of steering damper operation



## REASSEMBLY AND REMOUNTING

Reassemble and remount the steering stem in the reverse order of removal and disassembly. Pay attention to the following points:

### OUTER RACES

- Press in the upper and lower outer races by using the special tool.

**09941-34513: Steering outer race installer**

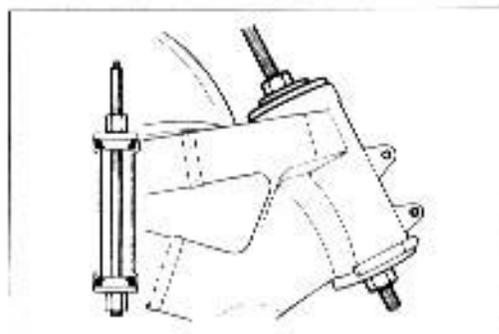

### BEARING

- Place a washer on the bearing and press in the lower bearing by using the special tool.

**09941-74910: Steering bearing installer**

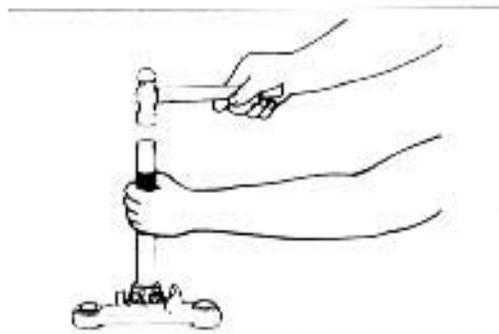

- Apply grease to the upper and lower bearings before re-mounting the steering stem.

(For U.S.A. model)

**99000-25030: SUZUKI SUPER GREASE "A"**

(For the other models)

**99000-25010: SUZUKI SUPER GREASE "A"**

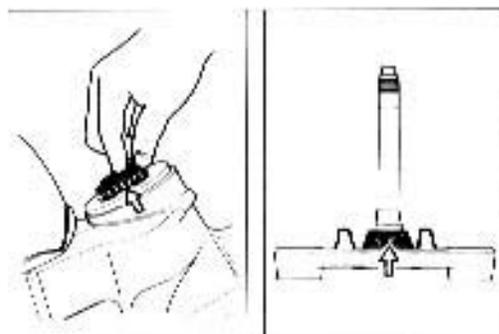

### STEM NUT

- Tighten the steering stem nut to the specified torque.

**09940-14911: Steering stem nut wrench**

Tightening torque: **40 – 50 N·m**

**(4.0 – 5.0 kg·m, 29.0 – 36.0 lb·ft)**

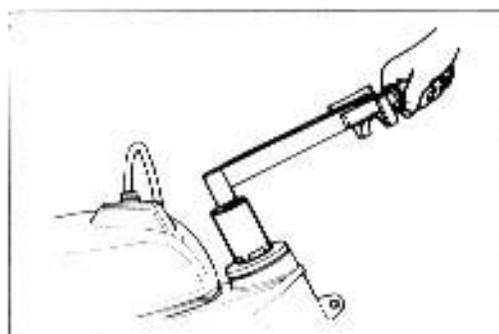

- Turn the steering stem lower bracket about five or six times to the left and right so that the taper roller bearing will be seated properly.
- Turn back the stem nut by 1/4 – 1/2 turn.

### NOTE:

*This adjustment will vary from motorcycle to motorcycle.*

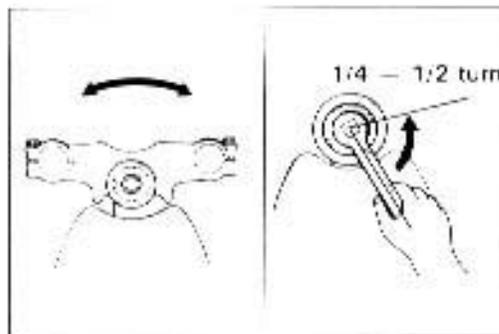

**HANDLEBAR HOLDER**

- Tighten the handlebar holder mounting bolts and nuts to the specified torque.

**Tightening torque:**

**Bolt (1): 50 – 60 N·m (5.0 – 6.0 kg·m, 36.0 – 43.5 lb-ft)**

**Nut (2): 22 – 35 N·m (2.2 – 3.5 kg·m, 16.0 – 25.5 lb-ft)**

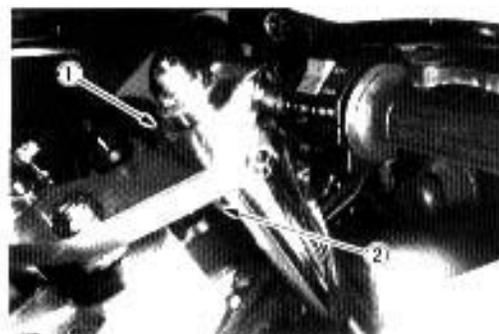
**STEERING DAMPER**

- Apply a grease to each bearing and dust seal. (Refer to page 6-17.)

(For U.S.A. model)

**99000-25030: SUZUKI SUPER GREASE "A"**

(For the other models)

**99000-25010: SUZUKI SUPER GREASE "A"**

- Place the steering damper bracket (1) onto the steering damper holder (2).

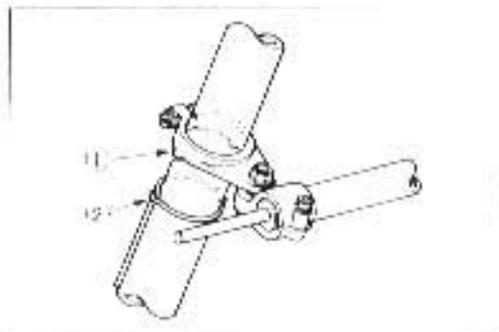

- Turn the steering to full left lock position to obtain 2 mm clearance (a) by turning the steering damper bracket (1).

**CAUTION:**

Do not turn the nut (3).

- Apply a small quantity of THREAD LOCK "1342" to the mounting bolts (f). (Refer to page 6-17.)

**99000-32050: THREAD LOCK "1342"**

- Tighten the steering damper bracket bolt and mounting bolts to the specified torque. (Refer to page 6-17.)

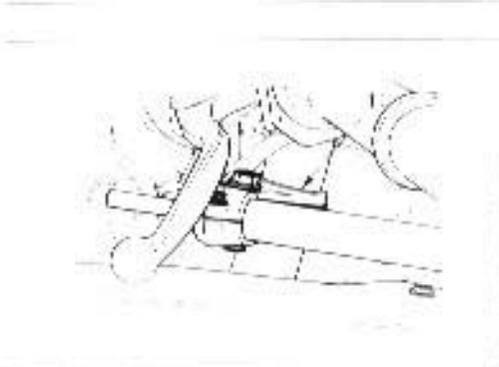
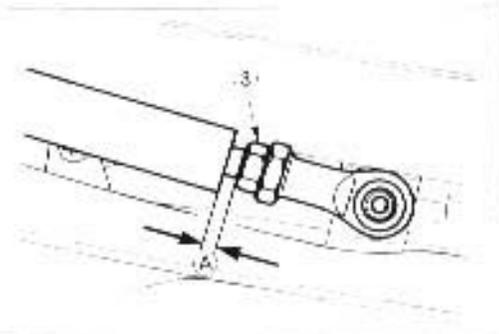

## STEERING TENSION ADJUSTMENT

Check the steering movement in the following procedure.

- Remove the lower fairing assembly.
- By using jacks at two (right and left) positions on the frame down tubes (lower straight portions), lift the front wheel until it is off the floor by 20 to 30 mm.
- Remove the front side of steering damper mounting bolt.
- Check to make sure that the cables and wire harnesses are properly routed.
- With the front wheel in the straight ahead state, hitch the spring scale (special tool) on one handlebar grip end as shown in the figure and read the graduation when the handlebar starts moving. Do the same on the other grip end.

**Initial force: 200 – 500 grams**

**09940-92710: Spring scale**

- If the initial force read on the scale when the handlebar starts turning is either too heavy or too light, adjust it till it satisfies the specification.
  - 1) First, loosen the front fork upper clamp bolts and steering stem head nut, and then adjust the steering stem nut by loosening or tightening it.
  - 2) Tighten the head nut and clamp bolts to the specified torque and re-check the initial force with the spring scale according to the previously described procedure.

### Tightening torque

**Stem head nut (1):** 50 – 80 N·m  
(5.0 – 8.0 kg-m, 36.0 – 58.0 lb-ft)

### Front fork

**Upper clamp bolt (2):** 22 – 35 N·m  
(2.2 – 3.5 kg-m, 16.0 – 25.5 lb-ft)

- 3) If the initial force is found within the specified range, adjustment has been completed.

### NOTE:

Hold the front fork legs, move them back and forth and make sure that the steering is not loose.

- Lower the jacks and install the lower fairing assembly.

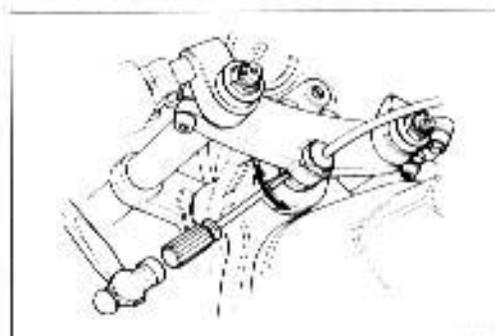
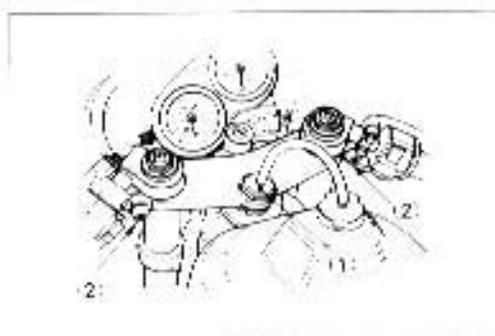
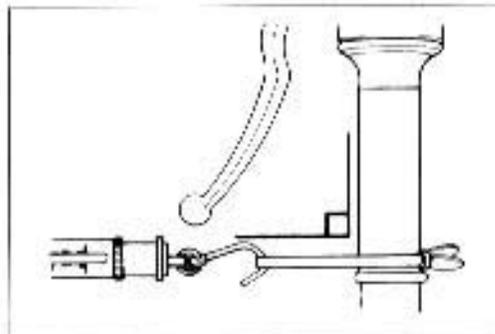
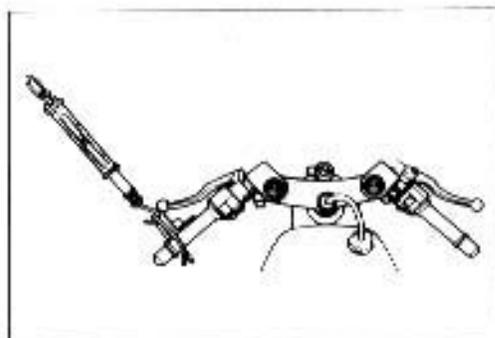

## IGNITION SWITCH

- To remove the ignition switch, remove the bolt to detach the ignition switch from the steering stem upper bracket by using a center punch and hammer.

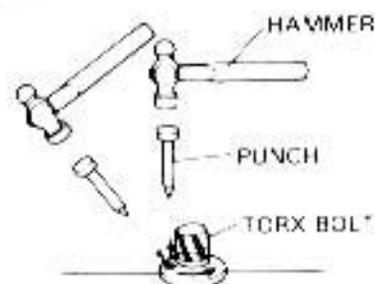
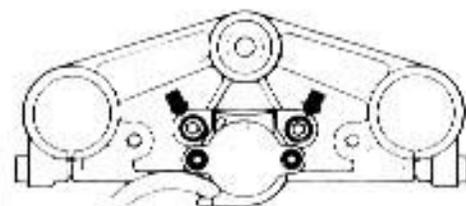

- To install the ignition switch, always use the new special bolt and follow the procedures below.

### NOTE:

*The spare ignition switch comes equipped with the special bolts, however, the bolt is also individually available as a spare part.*

- Using the special bolts, attach the ignition switch on the steering stem upper bracket in place and run in the bolts with the special tool.

### 09930-11910: Torx wrench

- Continue turning the tool until the tool slips from the bolt head or the bolt head breaks off, then the bolt has become tightened to the proper specification.

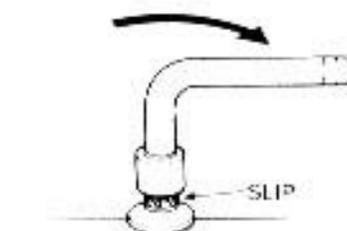
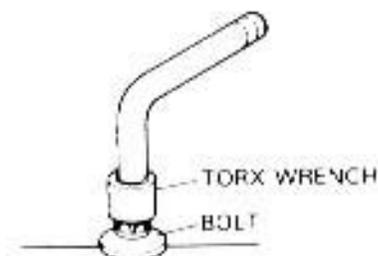

## REAR BRAKE

Tightening torque

Item	N·m	kg·m	lb·ft
Ⓐ	20 - 25	2.0 - 2.5	14.5 - 18.0
Ⓑ	18 - 28	1.8 - 2.8	13.0 - 20.0
Ⓒ	18 - 28	1.8 - 2.8	13.0 - 20.0
Ⓓ	30 - 36	3.0 - 3.6	21.5 - 26.0
Ⓔ	6 - 9	0.6 - 0.9	4.5 - 6.5

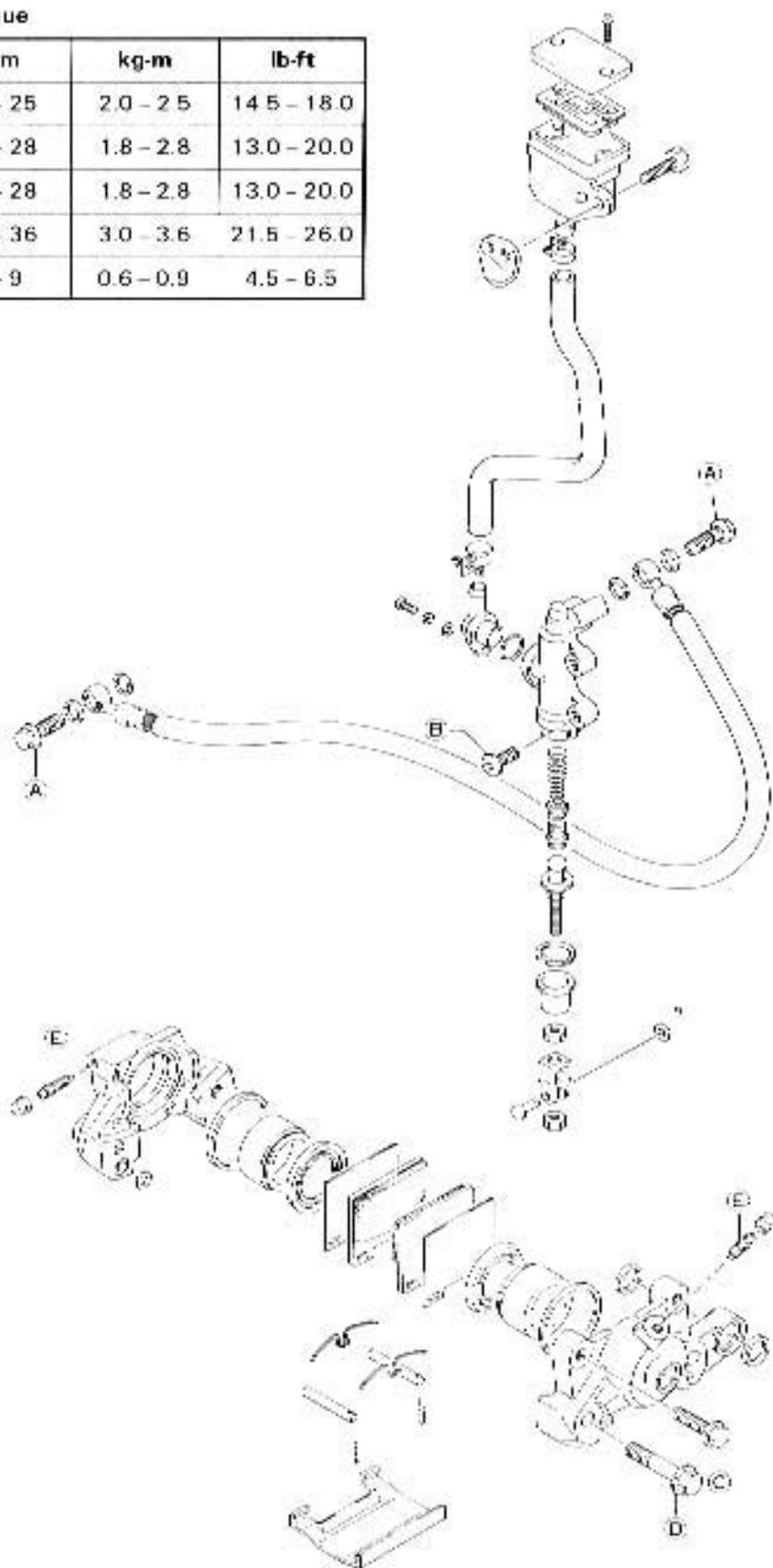

## BRAKE PAD REPLACEMENT

1. Remove the dust seal cover.
2. Remove the clips, pins and springs.
3. Remove the pads.

### CAUTION:

- Do not operate the brake pedal while dismounting the pads.
- Replace the brake pad as a set, otherwise braking performance will be adversely affected.

## CALIPER REMOVAL AND DISASSEMBLY

1. Remove the brake hose union bolt and catch brake fluid in a suitable receptacle.

### CAUTION:

Never re-use the brake fluid left over from previous servicing and stored for long periods.

### WARNING:

Brake fluid, if it leaks, will interfere with safe running and discolor painted surfaces. Check the brake hose and hose joint for cracks and oil leakage.

2. Remove the caliper mounting bolts.
3. Remove the torque link bolt and nut, and take off the caliper.

### NOTE:

Slightly loosen the caliper housing bolts ① to facilitate later disassembly before removing the caliper mounting bolts.

4. Remove the pads.
5. Remove the caliper housing bolts and separate the caliper halves.
6. Remove the O ring.

### NOTE:

Once separate the caliper halves, replace the O ring with a new one.

7. Place a rag over the piston to prevent it from popping out and push out the piston by using air gun.

### CAUTION:

Do not use high pressure air to prevent piston damage.

8. Remove the dust seal, piston and piston seal out of the caliper.

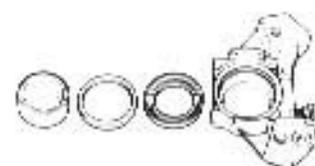
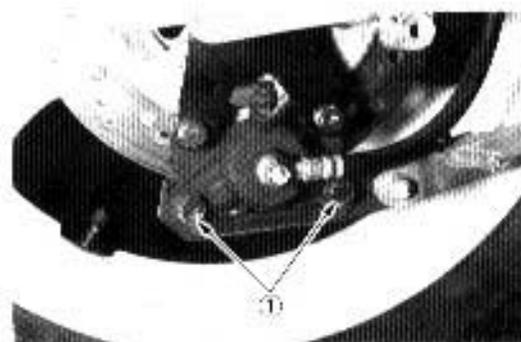

## CALIPER AND DISC INSPECTION

CALIPER .....	Refer to page 6-8.
PISTON .....	Refer to page 6-8.
RUBBER PARTS .....	Refer to page 6-8.
DISC .....	Refer to page 6-8.

## CALIPER REASSEMBLY AND REMOUNTING

Reassemble and remount the caliper in the reverse order of removal and disassembly. Pay attention to the following points:

### CAUTION:

- \* Wash the caliper components with fresh brake fluid before reassembly.
- \* Never use cleaning solvent or gasoline to wash them.
- \* Apply brake fluid to the caliper bore and piston to be inserted into the bore.
- \* Bleed air from the system after reassembling the caliper. (Refer to page 2-14.)

### Tightening torque:

- ①: 20 – 25 N·m (2.0 – 2.5 kg-m, 14.5 – 18.0 lb-ft)
- ②: (For U.S.A. and Canada models)  
18 – 28 N·m (1.8 – 2.8 kg-m, 13.0 – 20.0 lb-ft)  
(For the other models)  
22 – 34 N·m (2.2 – 3.4 kg-m, 16.0 – 24.5 lb-ft)
- ③: 30 – 36 N·m (3.0 – 3.6 kg-m, 21.5 – 26.0 lb-ft)
- ④: 18 – 28 N·m (1.8 – 2.8 kg-m, 13.0 – 20.0 lb-ft)

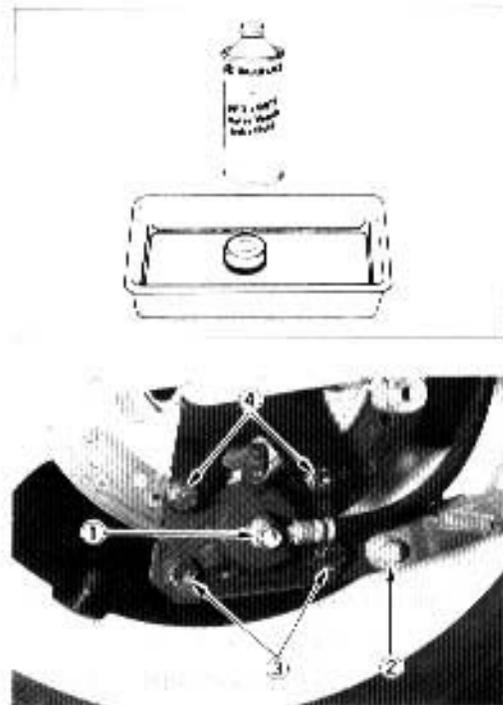

## MASTER CYLINDER REMOVAL AND DISASSEMBLY

1. Remove the seat.
2. Remove the reservoir tank mounting bolt.
3. Place a rag underneath the union bolt on the master cylinder to catch any spilled drops of brake fluid. Unscrew the union bolt and disconnect the brake hose from the master cylinder joint.

### CAUTION:

Immediately and completely wipe off any brake fluid contacting any part of the motorcycle. The fluid reacts chemically with paint, plastics and rubber materials, etc. and will damage them severely.

4. Remove the right footrest with the master cylinder.

09900-00410: Hexagon wrench set  
(Not available in U.S.A.)

### NOTE:

Slightly loosen the master cylinder mounting bolts to facilitate later disassembly before removing the right footrest bracket bolts.

5. Disconnect the rear brake light switch lead wires.
6. Pull out the brake pedal cotter pin.
7. Remove the master cylinder mounting bolts.
8. Remove the master cylinder assembly from the reservoir tank and its hose.

9. Remove the dust seal, then remove the circlip by using the special tool.

09900-06105: Snap ring pliers

- Remove the push rod, piston/secondary cup, primary cup and spring.

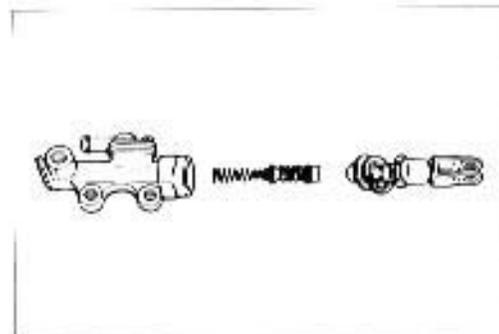
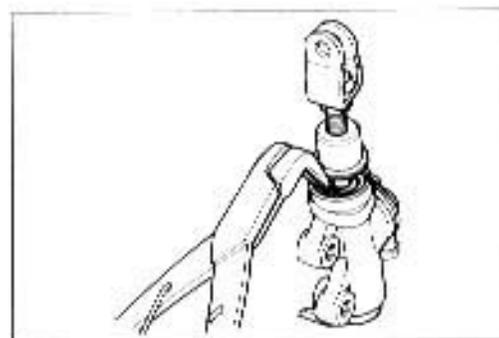
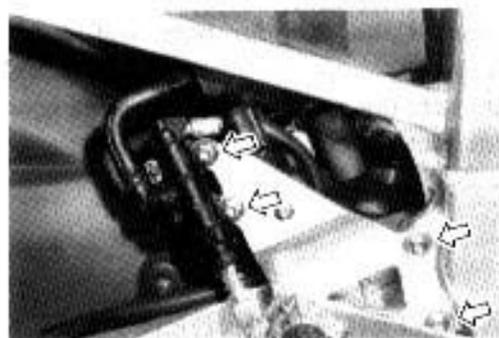



- Remove the connector and O-ring.

**CAUTION:**

The removed O-ring should be replaced with a new one.

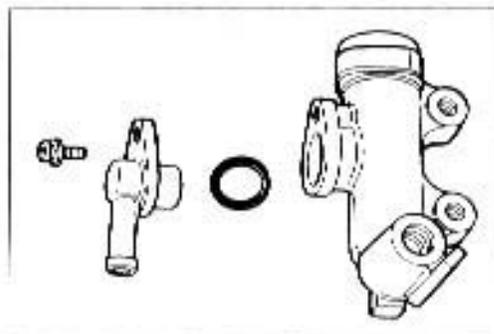

## MASTER CYLINDER INSPECTION

### CYLINDER, PISTON AND CUP SET

Inspect the cylinder bore wall for any scratches or other damage.

Inspect the piston surface for any scratches or other damage.

Inspect the cup set and each rubber part for wear or damage.

## MASTER CYLINDER REASSEMBLY AND REMOUNTING

Reassemble and remount the master cylinder in the reverse order of removal and disassembly. Pay attention to the following points:

**CAUTION:**

Wash the master cylinder components with fresh brake fluid before reassembly. Never use cleaning solvent or gasoline to wash them. Apply brake fluid to the cylinder bore and all the internals to be inserted into the bore.

**CAUTION:**

Bleed air from the system after reassembling master cylinder. (Refer to page 2-14.)

Adjust the rear brake light switch and brake pedal height after installation. (Refer to page 2-13.)



## REAR WHEEL

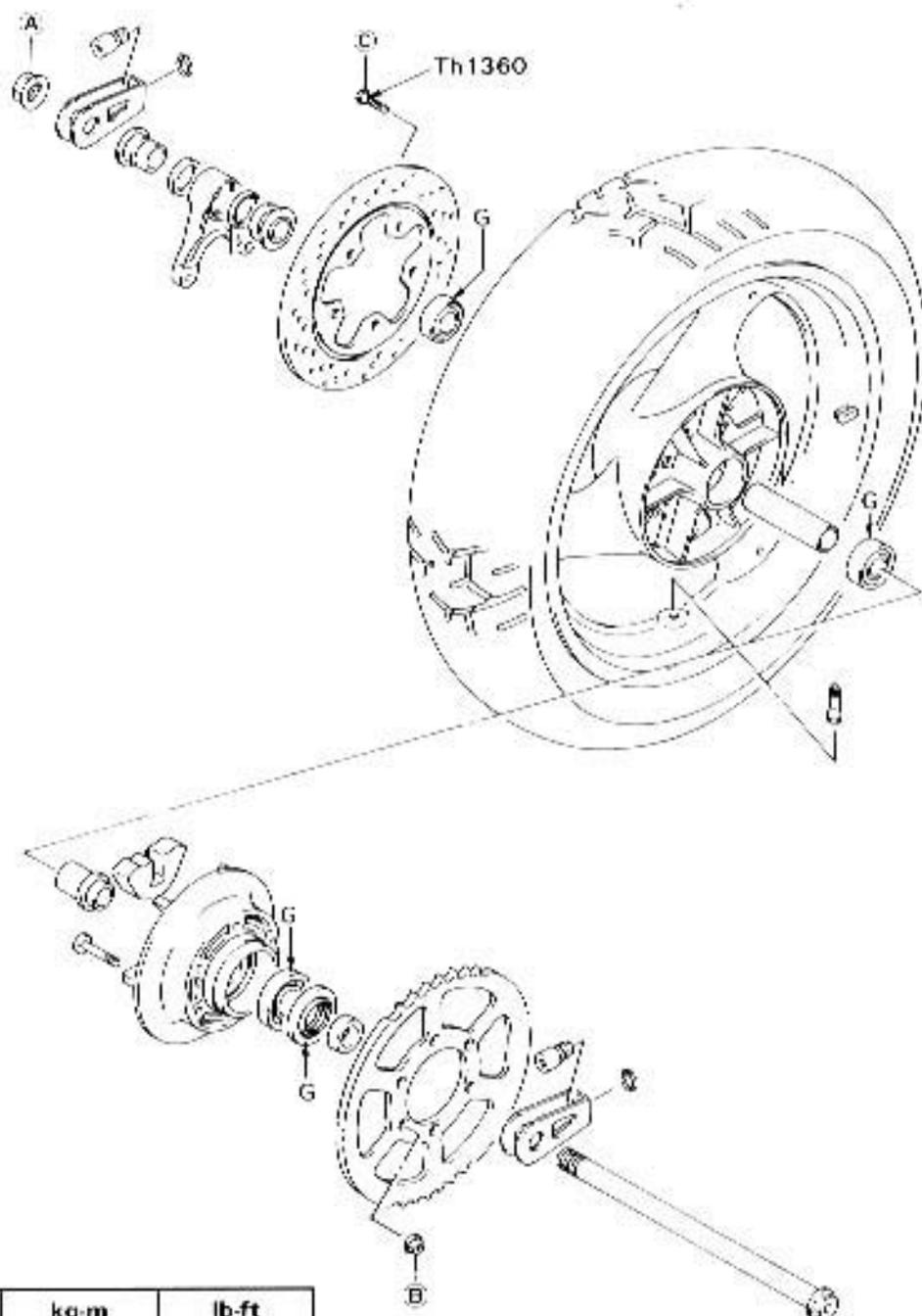

## Tightening torque

Item	N·m	kg·m	lb·ft
Ⓐ	85 - 115	8.5 - 11.5	61.5 - 83.0
Ⓑ	48 - 72	4.8 - 7.2	35.0 - 52.0
Ⓒ	15 - 25	1.5 - 2.5	11.0 - 18.0

G: Apply SUPER GREASE "A".  
Th1360: Apply THREAD LOCK SUPER "1360".

## REMOVAL

1. Remove the lower fairing assembly.
2. Support the motorcycle with a jack or wooden block.
3. Remove the caliper mounting bolts.
4. Remove the caliper along with torque link at the portion mounting it.

### CAUTION:

Do not operate the brake pedal while dismantling the brake caliper.

5. Remove the rear axle nut.
6. Loosen the chain adjusters, left and right.
7. Draw out the axle shaft.
8. Disengage the drive chain from the rear sprocket.
9. Remove the rear wheel.
10. Remove the rear sprocket along with its mounting drum off the wheel hub.

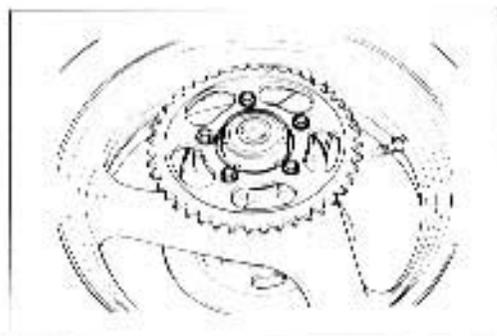

11. Remove the dampers out of the wheel hub.

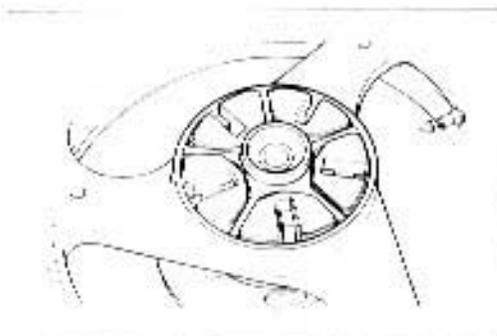

12. Remove the disc brake by removing the mounting bolts.

**09900-00410: Hexagon wrench set**  
(Not available in U.S.A.)

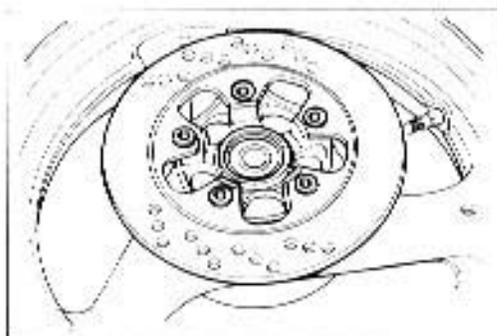

## INSPECTION AND DISASSEMBLY

**TIRE**..... Refer to page 6-34

### WHEEL AND SPROCKET DRUM BEARINGS

Inspect the play of the respective bearings by hand while they are in the wheel and sprocket drum. Rotate the inner race by hand to inspect for abnormal noise and smooth rotation. Replace the bearing if there is anything unusual.

- Drive out the wheel bearings and sprocket drum bearing by using a proper tool.

#### CAUTION:

The removed bearings and oil seal should be replaced with new ones.

### AXLE SHAFT

Using a dial gauge, check the axle shaft for runout and replace it if the runout exceeds the limit.

09900-20606: Dial gauge (1/100)

09900-20701: Magnetic stand | Not available

09900-21304: V-block set (100 mm) | in U.S.A

Service limit : 0.25 mm (0.010 in)

### WHEEL

Make sure that the wheel runout checked as shown does not exceed the service limit. An excessive runout is usually due to worn or loose wheel bearings and can be reduced by replacing the bearings. If bearing replacement fails to reduce the runout, replace the wheel.

Service limit (Axial and Radial): 2.0 mm (0.08 in)

### SPROCKET

Inspect the sprocket teeth for wear. If they are worn as illustrated, replace the sprocket and drive chain.

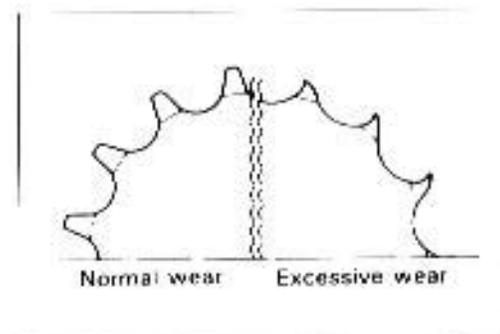
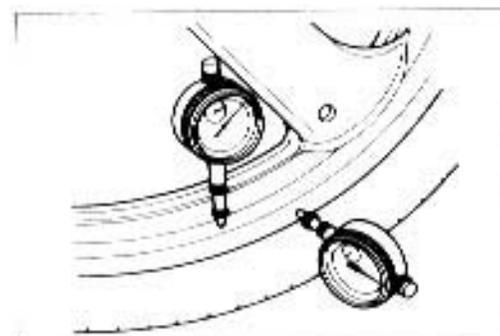
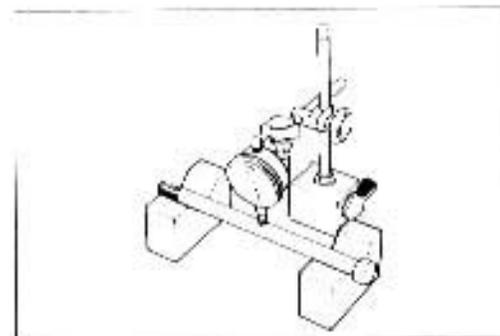
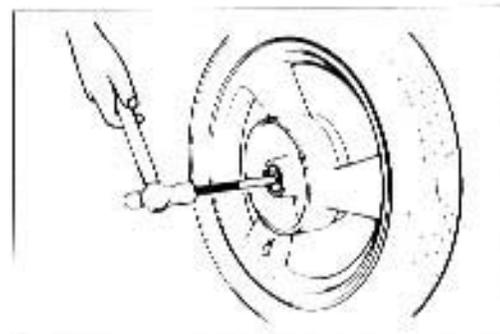
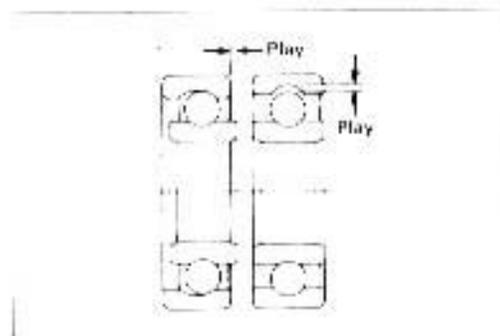

- Remove the rear sprocket by removing the mounting nuts.



### DAMPER

Inspect the dampers for wear and damage.

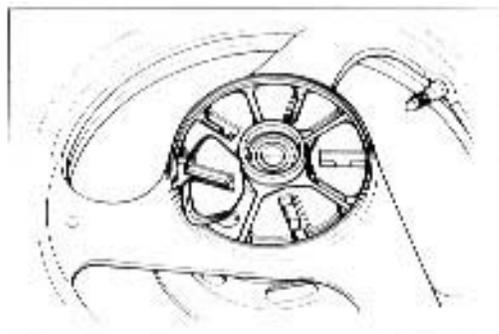

### REASSEMBLY AND REMOUNTING

Reassemble and remount the rear wheel in the reverse order of removal and disassembly. Pay attention to the following points:

#### WHEEL BEARING

- Apply grease to the bearings before installing.

[For U.S.A. model]

**99000-25030: SUZUKI SUPER GREASE "A"**

[For the other models]

**99000-25010: SUZUKI SUPER GREASE "A"**

- Install the wheel bearings by using the special tools.

**09924-84510: Bearing installer set**

#### NOTE:

*First install the right wheel bearing, then install the left wheel bearing. The sealed cover on the bearing is positioned outside. Refer to next page.*

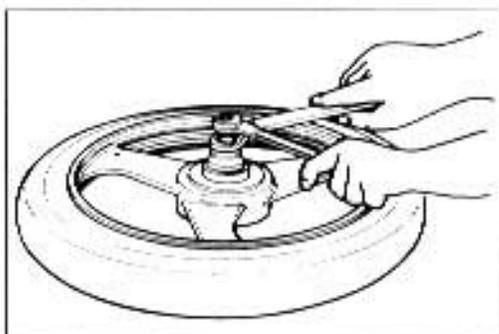

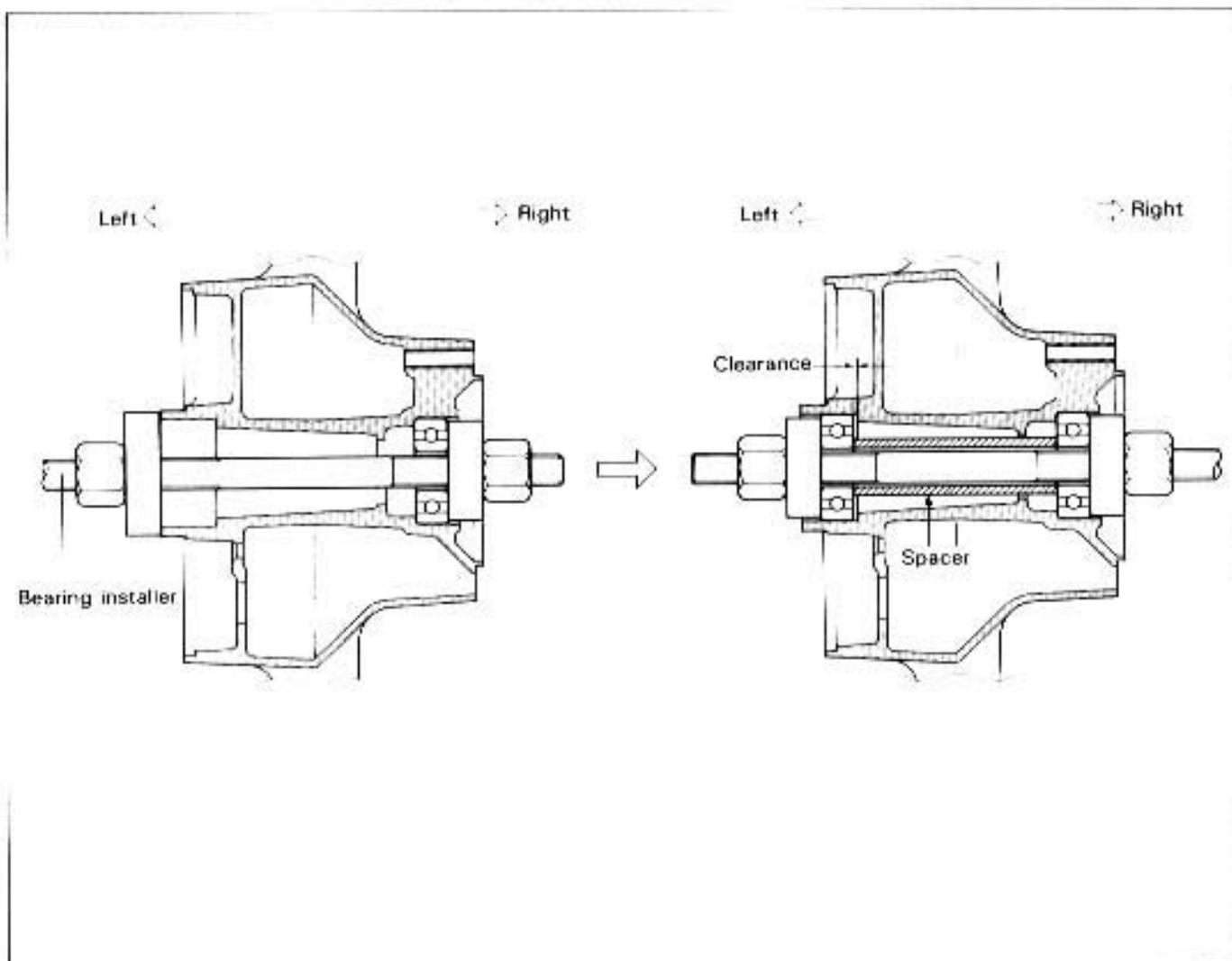

### SPROCKET DRUM BEARING AND SPROCKET

- Install the bearing by using the special tool.

**09913-75520: Bearing installer**

- Apply grease to the bearing and oil seal lip.

(For U.S.A.model)

**99000-25030: SUZUKI SUPER GREASE "A"**

(For the other models)

**99000-25010: SUZUKI SUPER GREASE "A"**

#### NOTE:

*When installing the rear sprocket on its mounting drum, the stamped mark on the sprocket is positioned outside.*

- Tighten the sprocket mounting nuts to the specified torque.

**Tightening torque: 48 - 72 N·m**

**(4.8 - 7.2 kg-m, 35.0 - 52.0 lb-ft)**

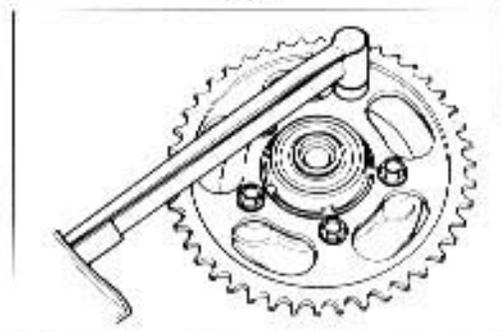
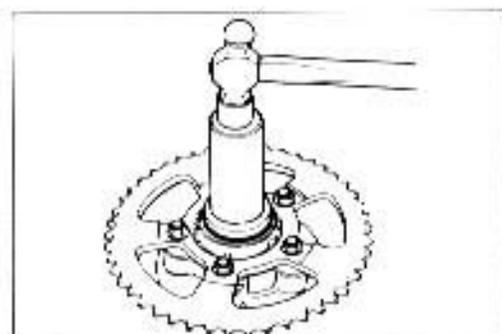

### BRAKE DISC

- Make sure that the brake disc is clean and free of any greasy matter.
- Apply **THREAD LOCK SUPER "1360"** to the disc mounting bolts and tighten them to the specified torque.

**99000-32130: THREAD LOCK SUPER "1360"**

**Tightening torque: 15 – 25 N·m  
{1.5 – 2.5 kg·m, 11.0 – 18.0 lb-ft}**

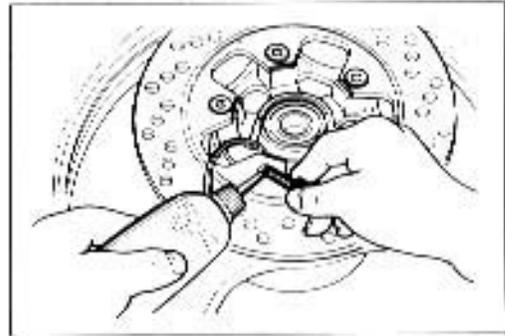

### TIGHTENING TORQUE

**Axle nut:**

**85 – 115 N·m (8.5 – 11.5 kg·m, 61.5 – 83.0 lb-ft)**

**Brake caliper mounting bolt:**

**18 – 28 N·m (1.8 – 2.8 kg·m, 13.0 – 20.0 lb-ft)**

### ADJUSTMENT

- Adjust the chain slack after rear wheel installation.  
(Page 2-11)

## TIRE AND WHEEL

### TIRE REMOVAL

The most critical factor of a tubeless tire is the seal between the wheel rim and the tire bead. Because of this, we recommend using a tire changer which is also more efficient than tire levers.

For tire removal the following tools are required.

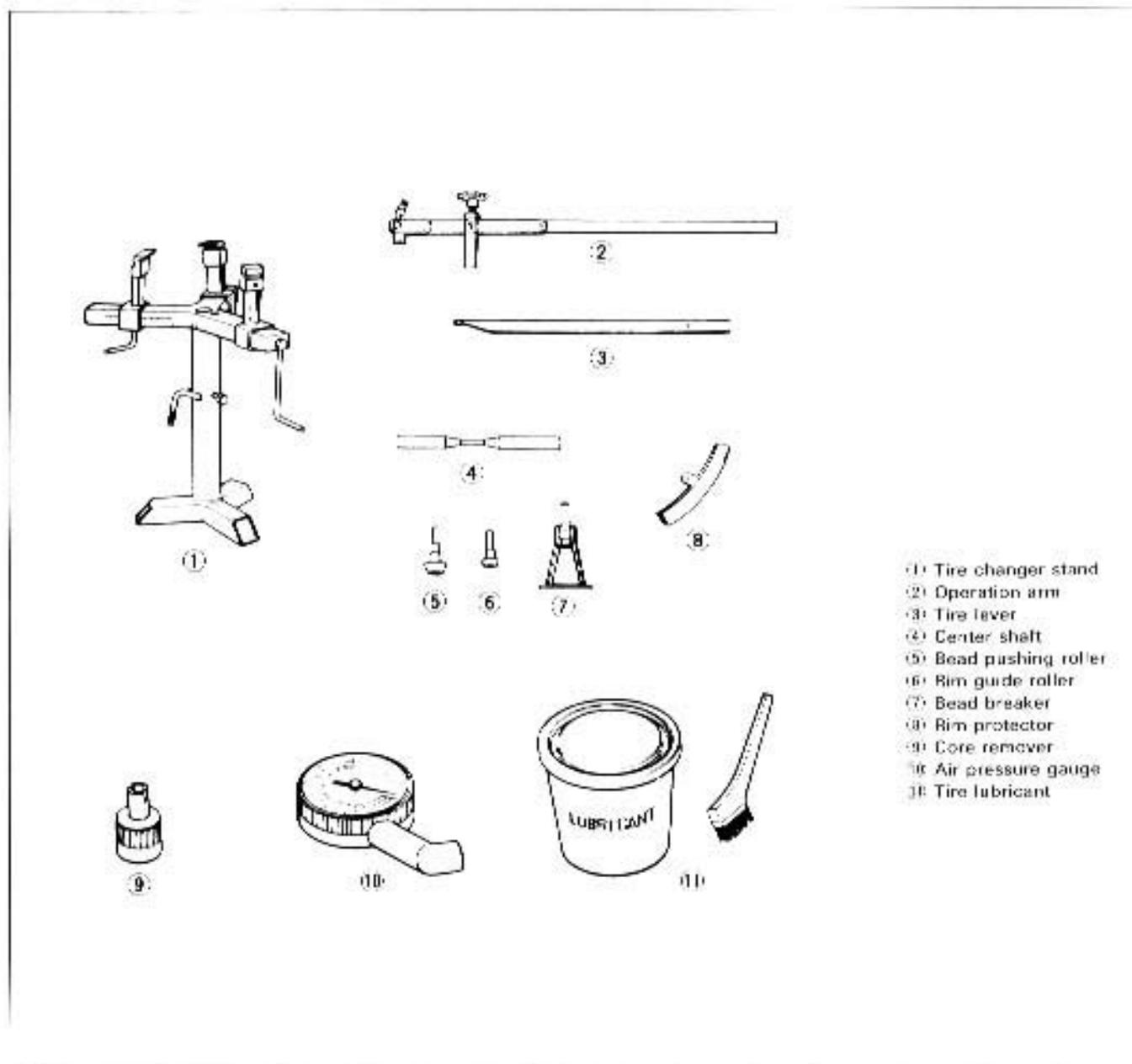

- Remove the valve core from the valve stem, and deflate the tire completely.

**NOTE:**

Mark the tire with chalk to note the position ① of the tire on the rim and rotational direction ② of the tire.

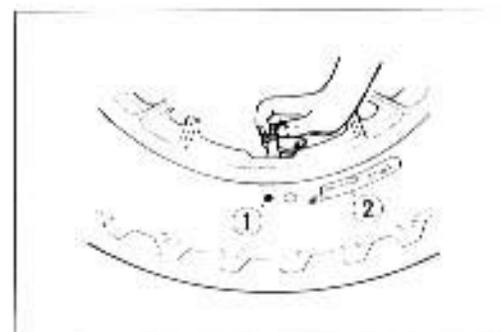



- Place the center shaft (1) to the wheel, and fix the wheel with the rim holder (2).

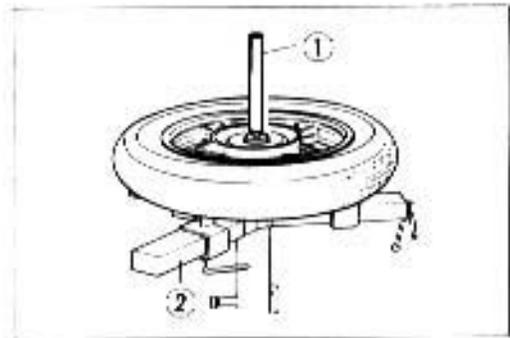

- Attach the operation arm (3) to the center shaft.

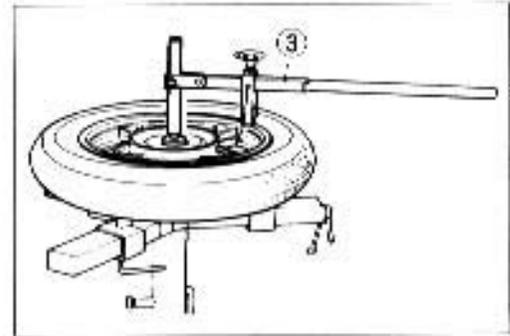

- Attach the bead breaker (4) to the operation arm, and dismount the bead from the rim. Turn the wheel over and dismount the other bead from the rim.

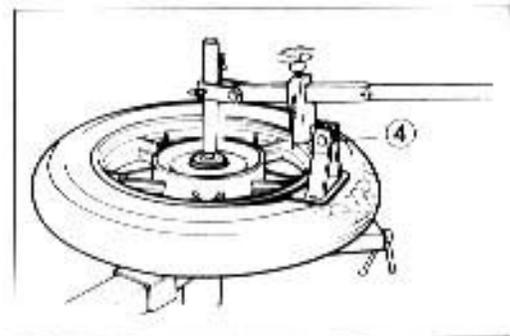

- Install the rim guide roller (5).
- Install the rim protector (6), and raise the bead with the tire lever (7).

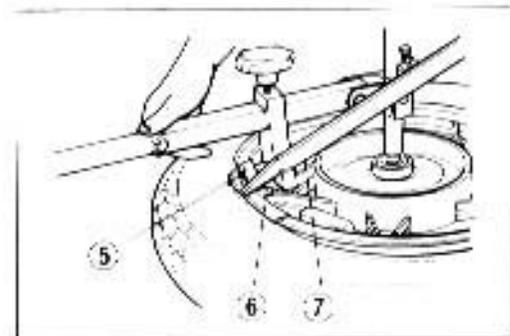

- Set the tire lever against the operation arm, and rotate the lever around the rim. Repeat this procedure to remove the other bead from the rim.

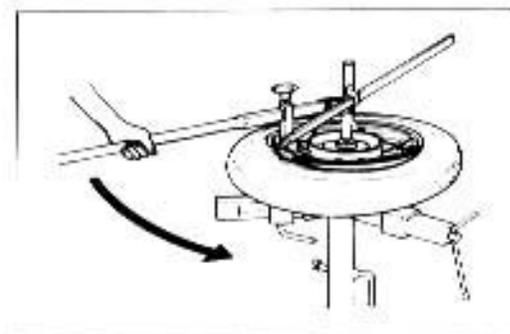

## INSPECTION

### WHEEL

Wipe off any rubber substance or rust from the wheel, and inspect the wheel rim. If any one of the following items is observed, replace it with a new wheel.

- A distortion or crack.
- Any scratches or flaws in the bead seating area.
- Wheel runout (Axial & Radial) of more than 2.0 mm (0.08 in).

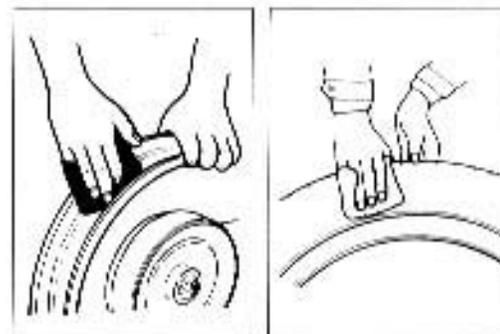

### TIRE

Thoroughly inspect the removed tire, and if any one of the following items is observed, do not repair the tire. Replace with a new one.

- A puncture or a split whose total length or diameter exceeds 6.0 mm (0.24 in).
- A scratch or split at the side wall.
- Tread depth less than 1.6 mm (0.06 in) in the front tire and less than 2.0 mm (0.08 in) in the rear tire.
- Ply separation.
- Tread separation.
- Tread wear is extraordinarily deformed or distributed around the tire.
- Scratches at the bead.
- Cord is cut.
- Damage from skidding (flat spots).
- Abnormality in the inner liner.

#### NOTE:

*When repairing a flat tire, follow the repair instructions and use only recommended repairing materials.*

### VALVE INSPECTION

Inspect the valve after the tire is removed from the rim, and replace with a new valve if the seal rubber has any splits or scratches.

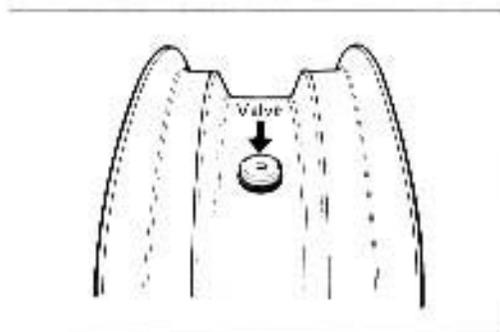

Inspect the removed valve core and replace with the new one if the seal rubber is abnormally deformed or worn.

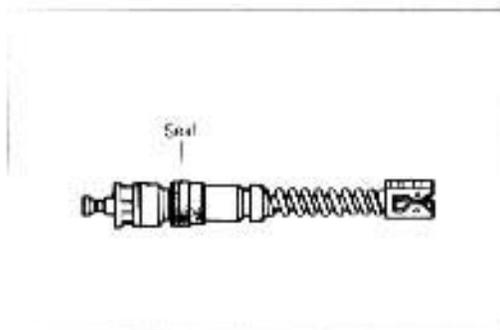

**VALVE INSTALLATION**

Any dust or rust around the valve hole must be cleaned off. Then install the valve in the rim.

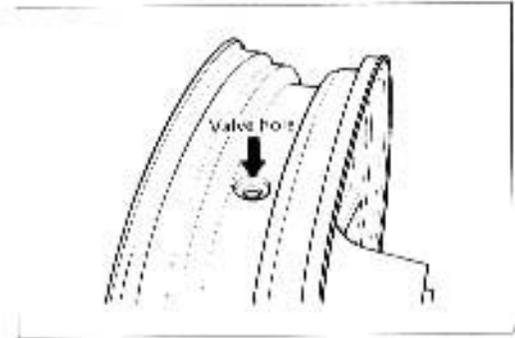
**CAUTION:**

When installing the valve, tighten the nut ① by hand as much as possible. Holding the nut ① under this condition, tighten the lock nut ②. Do not overtighten the nut ① as this may distort the rubber packing and cause an air leak.

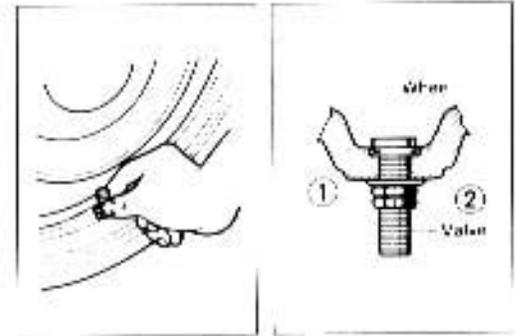
**TIRE MOUNTING**

- Apply a special tire lubricant or neutral soapy liquid to the tire bead.

**CAUTION:**

Never apply grease, oil or gasoline to the tire bead.

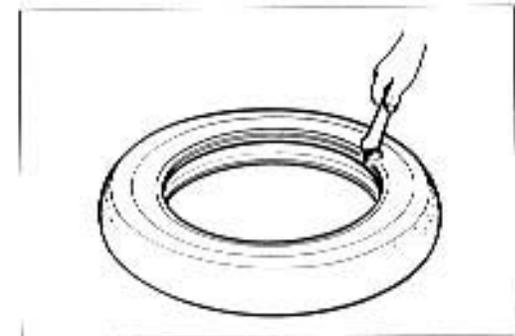

- When installing the tire, make certain that the directional arrow faces the direction of wheel rotation and align the balancing mark of the tire with the valve as shown.

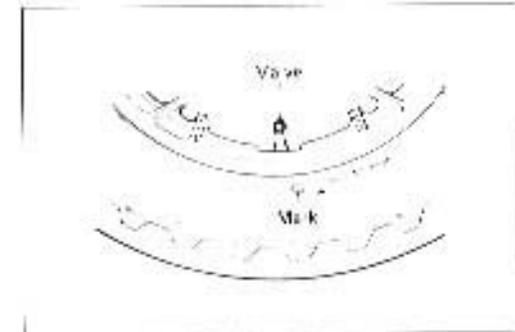

- Set the bead pushing roller (3).
- Rotate the operation arm around the rim to mount the bead completely. Do the bottom bead first, then the upper bead.
- Remove the wheel from the tire changer, and install the valve core in the valve stem.

**NOTE:**

*Before installing the valve core, inspect the core.*

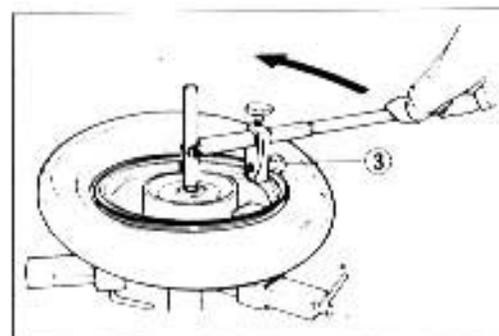

- Bounce the tire several times while rotating. This makes the tire bead expand outwards, and thus makes inflation easier.

**NOTE:**

*Before inflating, confirm that the balance mark lines up with the valve stem.*



- Pump up the tire with air.

**WARNING:**

**Do not inflate the tire to more than 400 kPa (4.0 kg/cm<sup>2</sup>, 58 psi). The tire could burst with sufficient force to cause severe injury. Never stand directly over the tire while inflating it.**

**NOTE:**

*Check the "rim line" cast on the tire side walls. It must be equidistant from the wheel rim all the way around. If the distance between the rim line and wheel rim varies, this indicates that the bead is not properly seated. If this is so, deflate the tire completely, and unseat the bead for both sides. Coat the bead with lubricant, and try again.*

- After tire is properly seated to the wheel rim, adjust the air-pressure to the recommended pressure. Correct the wheel balance if necessary.

**WARNING:**

- \* Do not run a repaired tire more than 50 km/h (30 mph) within 24 hours after tire repairing, since the patch may not be completely cured.
- \* Do not exceed 130 km/h (80 mph) with a repaired tire.

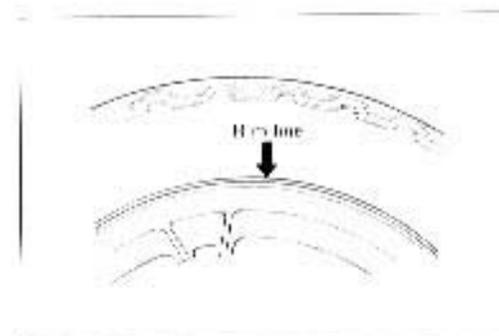
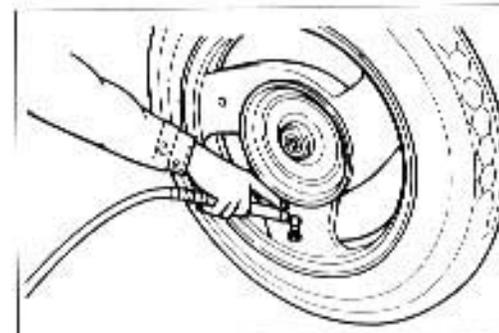

## REAR SUSPENSION SWINGARM

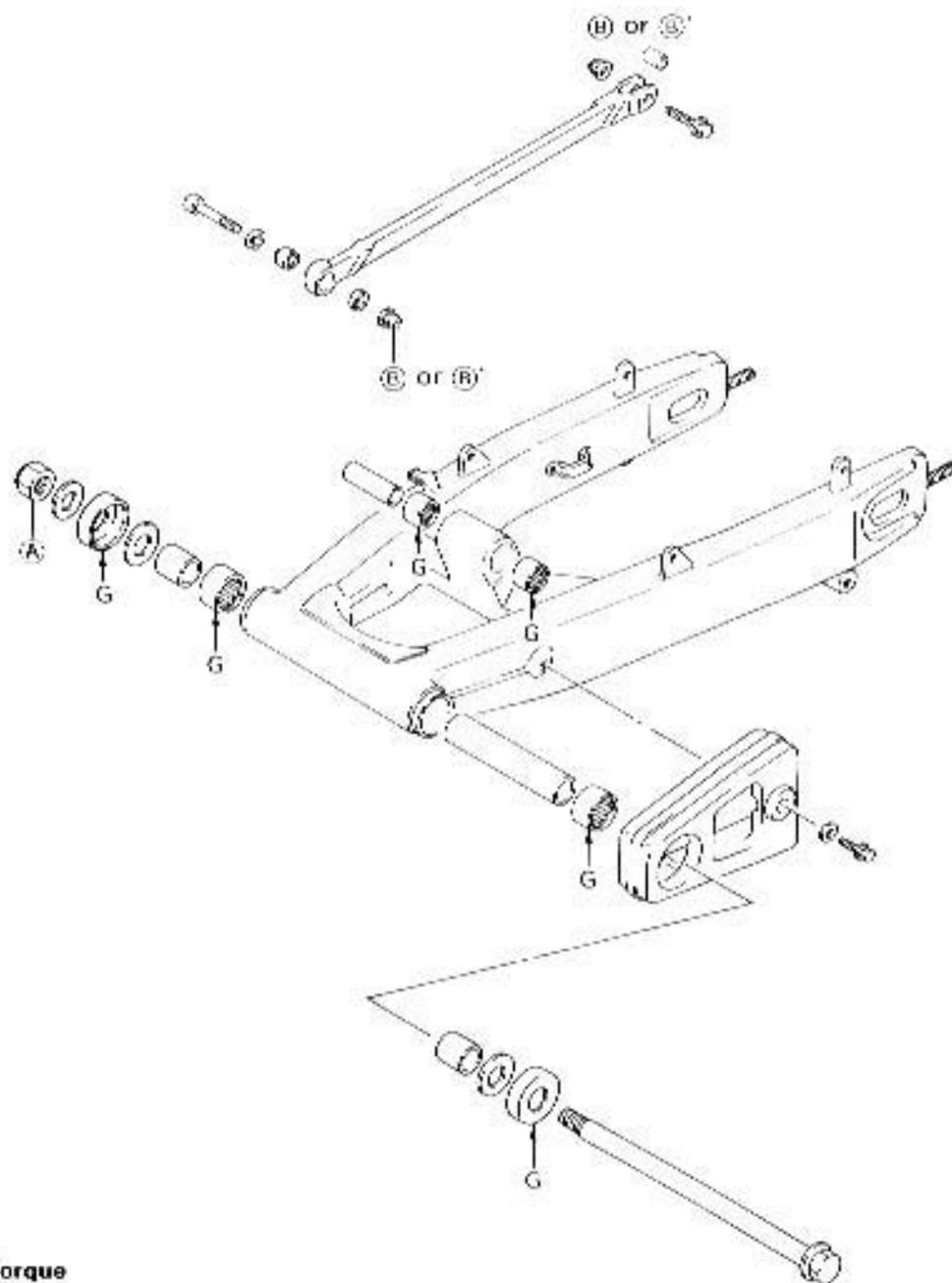

### Tightening torque

Item	N·m	kg·m	lb·ft
(A)	85 - 115	8.5 - 11.5	61.5 - 83.0
(B)	22 - 34	2.2 - 3.4	16.0 - 24.5
(B')	18 - 28	1.8 - 2.8	13.0 - 20.0

(B) : For E-03, 28 and 33 models

(B') : For the other models

G : Apply SUPER GREASE "A".

## SHOCK ABSORBER AND CUSHION LEVER

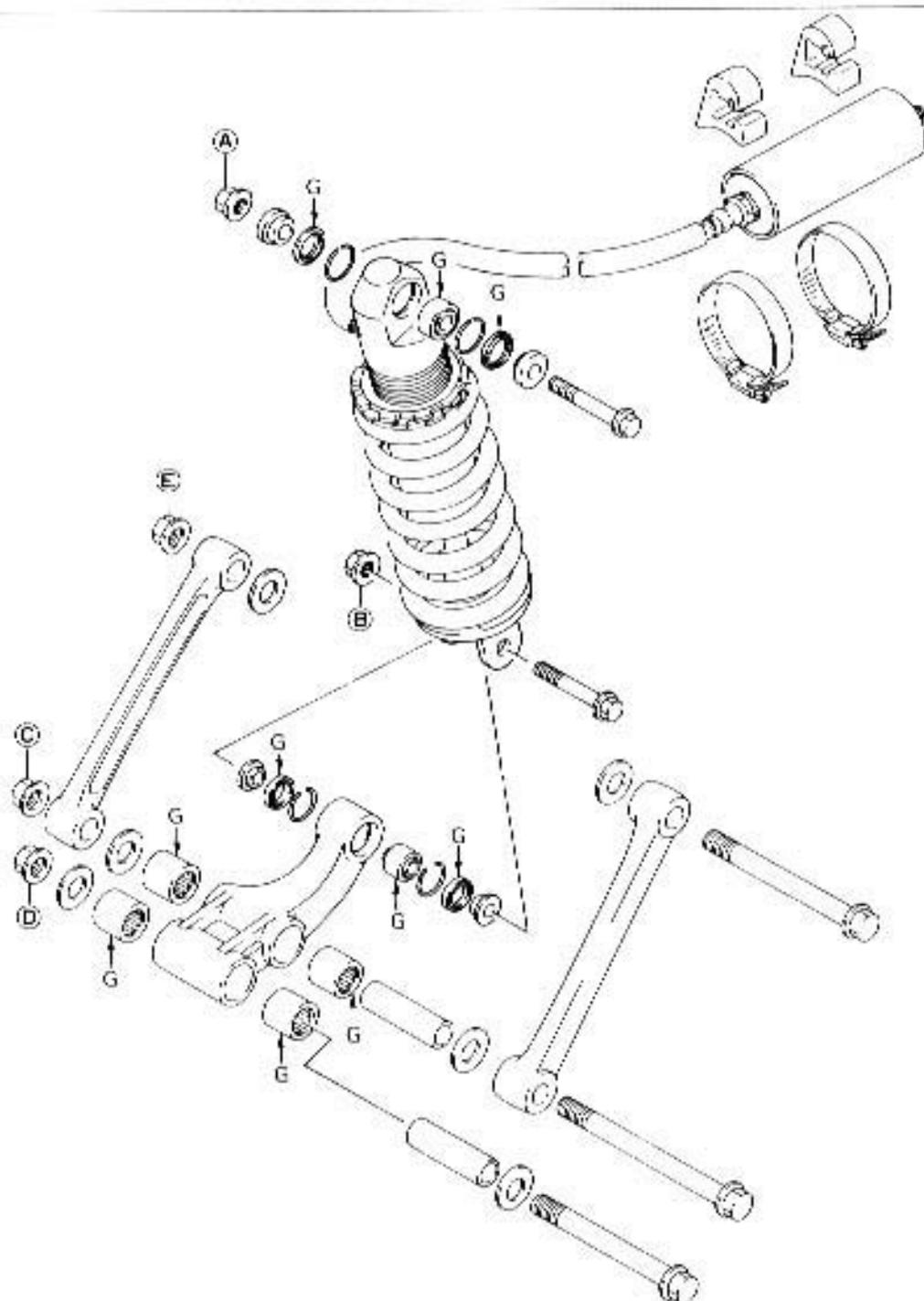

## Tightening torque

Item	N·m	kg·m	lb·ft
Ⓐ	40 - 60	4.0 - 5.0	29.0 - 43.5
Ⓑ			
Ⓒ			
Ⓓ	110 - 160	11.0 - 16.0	79.5 - 115.5
Ⓔ			

G: Apply SUPER GREASE "A"

## REMOVAL

1. Remove the lower fairing assembly.
2. Support the motorcycle with a jack or wooden block.
3. Remove both seats and left and right frame covers.
4. Remove the rear lower fender.
5. Remove the rear brake hose union bolt.

### CAUTION:

**Completely wipe off any brake fluid adhering to any part of motorcycle. The fluid reacts chemically with paint, plastics, rubber materials, etc.**

6. Remove the caliper mounting bolts.
7. Remove the rear axle nut.
8. Loosen the chain adjusters.
9. Draw out the axle shaft.
10. Remove the rear wheel.
11. Remove the swingarm pivot shaft.
12. Remove the shock absorber upper mounting bolt.
13. Remove the cushion lever mounting bolt.
14. Remove the shock absorber reservoir tank.
15. Remove the rear suspension assembly.
16. Remove the shock absorber, cushion lever and cushion rod from the swingarm.

## INSPECTION

### SWINGARM

Inspect the spacer for any flaws or other damage.

Insert the spacer in the bearing and check the play by moving the spacer up and down. If an excessive play is noted, replace the bearing with a new one.

Inspect each dust seal for wear and damage.

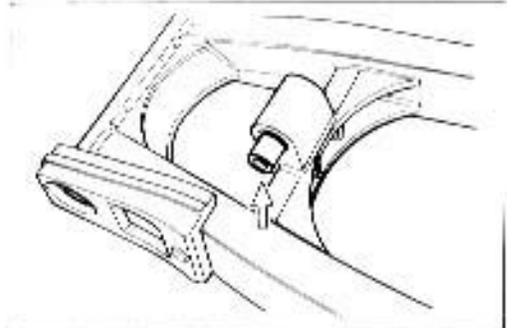
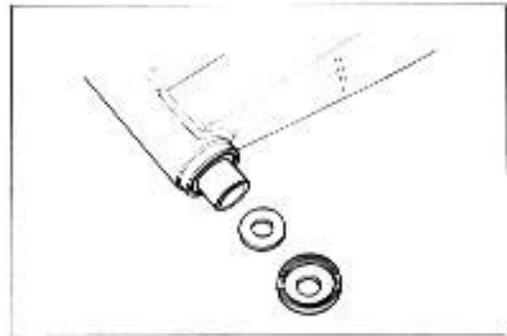

### CUSHION LEVER

Inspect the spacer for any flaws or other damage.

Insert the spacer in the bearing and check the play by moving the spacer up and down.

If an excessive play is noted, replace the bearing with a new one.

Inspect each dust seal for wear and damage.

**SHOCK ABSORBER**

Inspect the shock absorber body, bearing and oil hose for damage and oil leakage. If any defects are found, replace the shock absorber with new one.

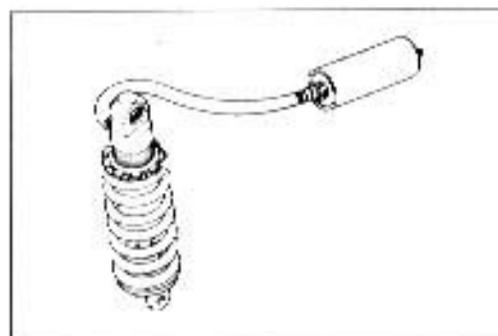
**SWINGARM PIVOT SHAFT**

Using a dial gauge, check the pivot shaft runout and replace it if the runout exceeds the limit.

09900-20606: Dial gauge (1/100)

09900-20701: Magnetic stand

09900-21304: V-block set (100 mm) | Not available in U.S.A

Service limit: 0.3 mm (0.01 in)

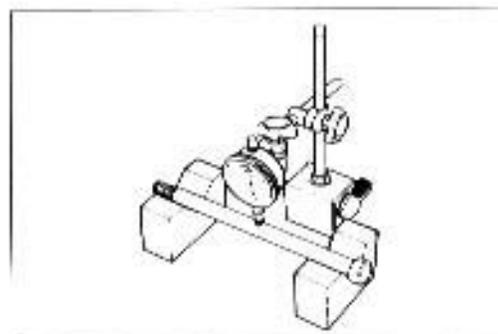
**DISASSEMBLY****SWINGARM**

- Remove the dust seals, washers and spacers from the swingarm pivot.

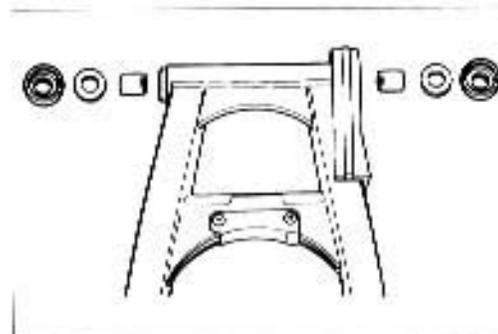

- Remove the swingarm bearings by using the special tool.

09941-44910: Swingarm bearing remover

**CAUTION:**

The removed bearings should be replaced with new ones.

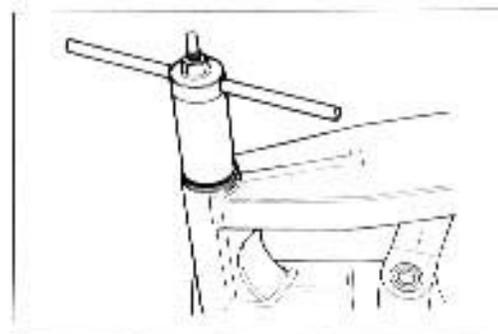

- Remove the bearing by using the special tool.

09923-74510: Bearing remover

09930-30102: Sliding shaft

**CAUTION:**

The removed bearings should be replaced with new ones.

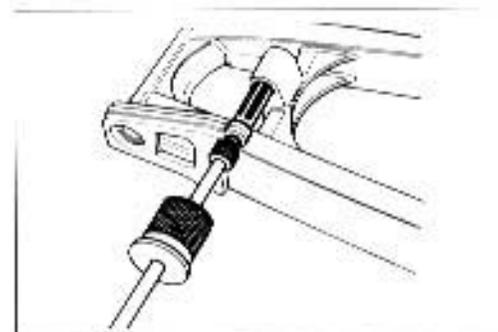



**CUSHION LEVER**

- Remove the spacers and dust seals.
- Remove the bearing stopper rings and drive out the bearing by using appropriate tool.

**CAUTION:**

The bearing and stopper rings removed once should be replaced with new ones.

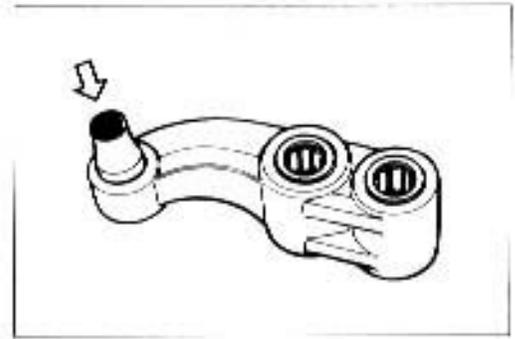

- Remove the bearing by using the special tool.

09923-74510: Bearing remover

09930-30102: Sliding shaft

**CAUTION:**

The removed bearings should be replaced with new ones.

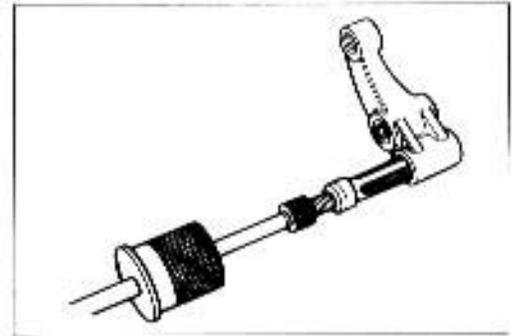

**SHOCK ABSORBER**

- Remove the spacers and dust seals.
- Remove the bearing stopper rings and drive out the bearing by using appropriate tool.

**CAUTION:**

The bearing and stopper rings once removed should be replaced with new ones.

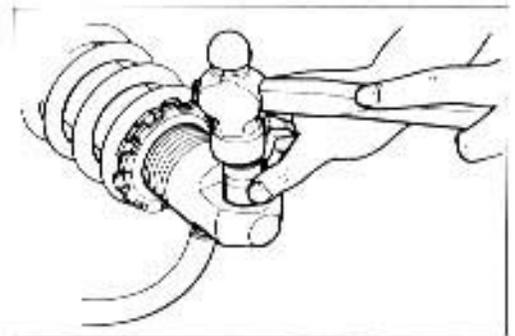

## REASSEMBLY INFORMATION

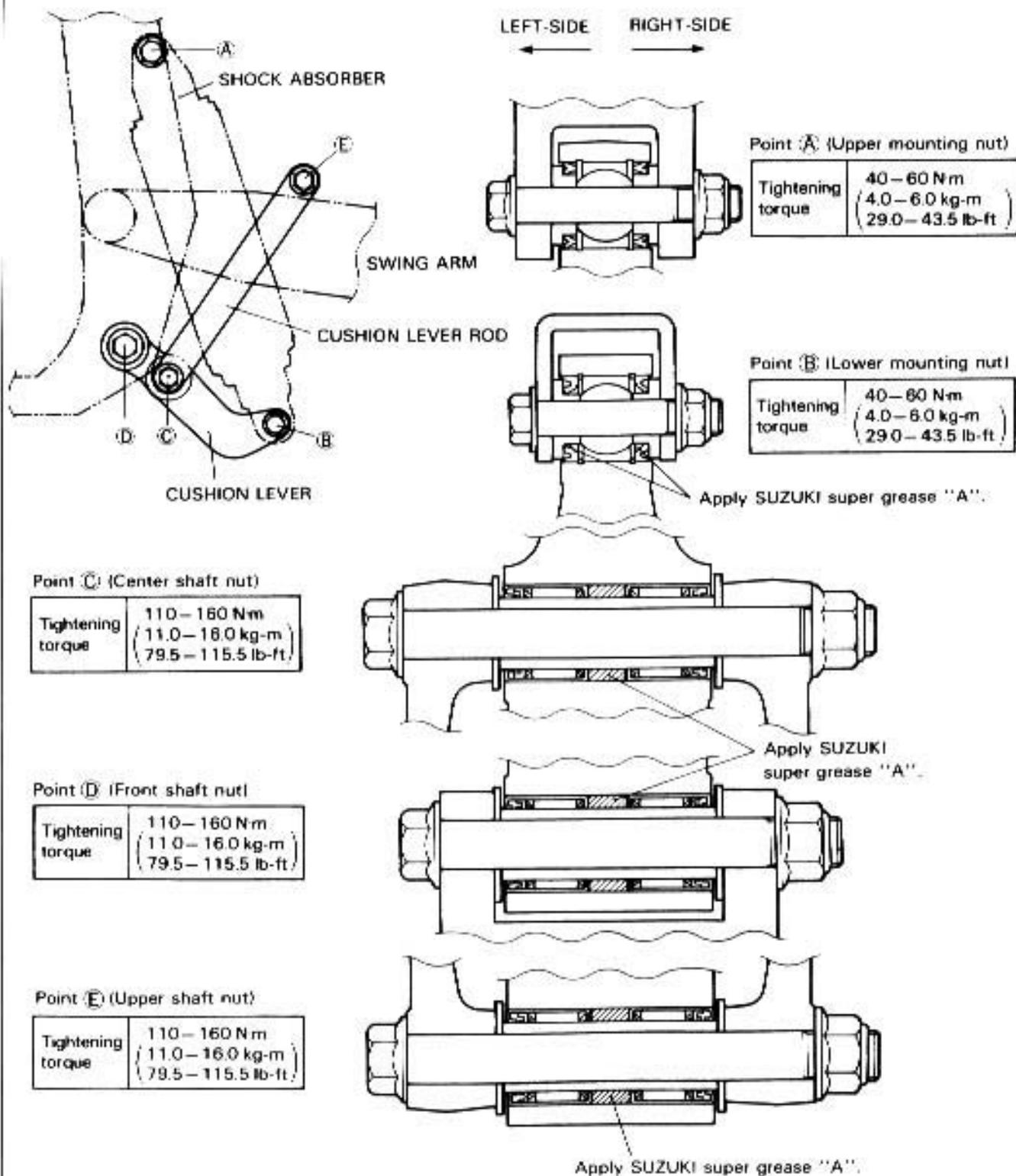

## REASSEMBLY AND REMOUNTING

Reassemble and remount the swingarm, rear shock absorber, rear cushion lever rods and cushion lever. Pay attention to the following points:

### SWINGARM

- Force-fit the bearings into the swingarm pivot and rod mounting portion.

**09941-34513: Steering outer race installer**

#### NOTE:

*When installing the bearings, punch-marked side of bearing faces outside.*

- Apply grease to the bearings, spacers and dust seals when installing them.

(For U.S.A. model)

**99000-25030: SUZUKI SUPER GREASE "A"**

(For the other models)

**99000-25010: SUZUKI SUPER GREASE "A"**

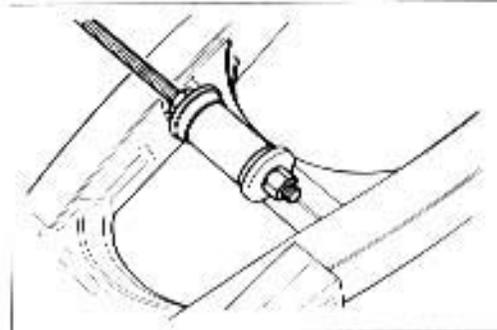
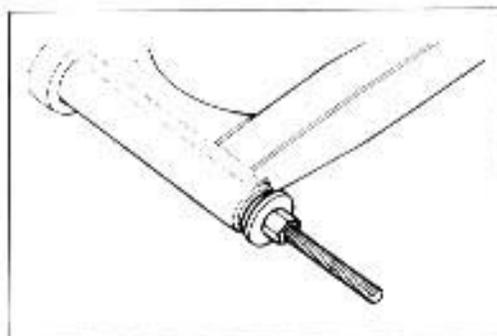

### CUSHION LEVER

- Force fit the bearings into the cushion lever pivot and rod mounting portion.
- Install the bearing by using appropriate tool.

#### NOTE:

*When installing the bearings, punch-marked side of bearing faces outside.*

- Apply grease to the bearings, spacers and dust seals when installing them.

(For U.S.A. model)

**99000-25030: SUZUKI SUPER GREASE "A"**

(For the other models)

**99000-25010: SUZUKI SUPER GREASE "A"**

- Tighten each nut to the specified torque, refer to the 6-44.

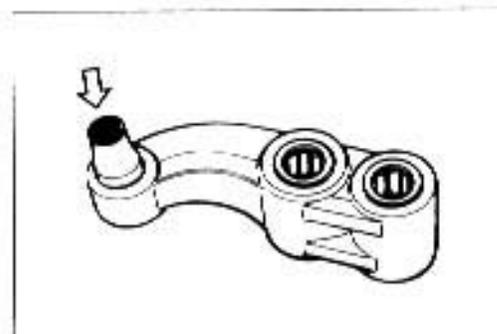

## FINAL INSPECTION AND ADJUSTMENT

After installing the rear suspension and rear wheel, the following adjustments are required before driving the motorcycle.

- \* Drive chain
- \* Rear brake
- \* Tire pressure
- \* Shock absorber

## SUSPENSION SETTING

Front and rear suspensions are adjustable according to the rider's requirement. The high speed capability of this motorcycle makes proper suspension setting and balance very important.

Use the following table to adjust the front and rear suspensions.

### FRONT SUSPENSION SETTING TABLE

Item		Spring pre-load	Damping force	
			Compression	Rebound
Solo riding	Softer	6	8	6
	Standard	5	5	4
	Stiffer	4	3	2
Dual riding		4 - 5	4 - 5	3 - 4

### REAR SUSPENSION SETTING TABLE

Item		Spring pre-load	Damping force
Solo riding	Softer	187.2 - 197.2 mm (7.37 - 7.76 in)	1
	Standard	192.2 mm (7.57 in)	2
	Stiffer	187.2 - 197.2 mm (7.37 - 7.76 in)	3
Dual riding		187.2 - 197.2 mm (7.37 - 7.76 in)	2 - 3

#### CAUTION:

Do not set the spring to a length less than 187.2 mm (7.37 in) or more than 197.2 mm (7.76 in).

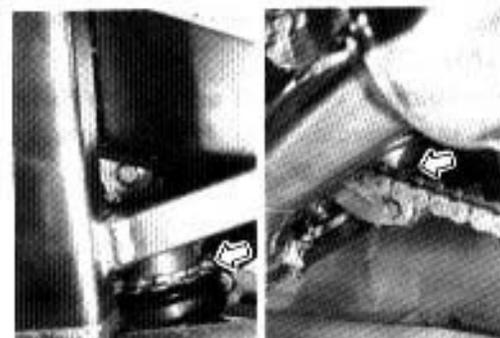
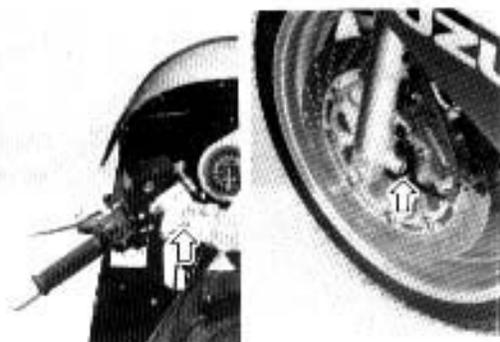

## CLUTCH MASTER CYLINDER

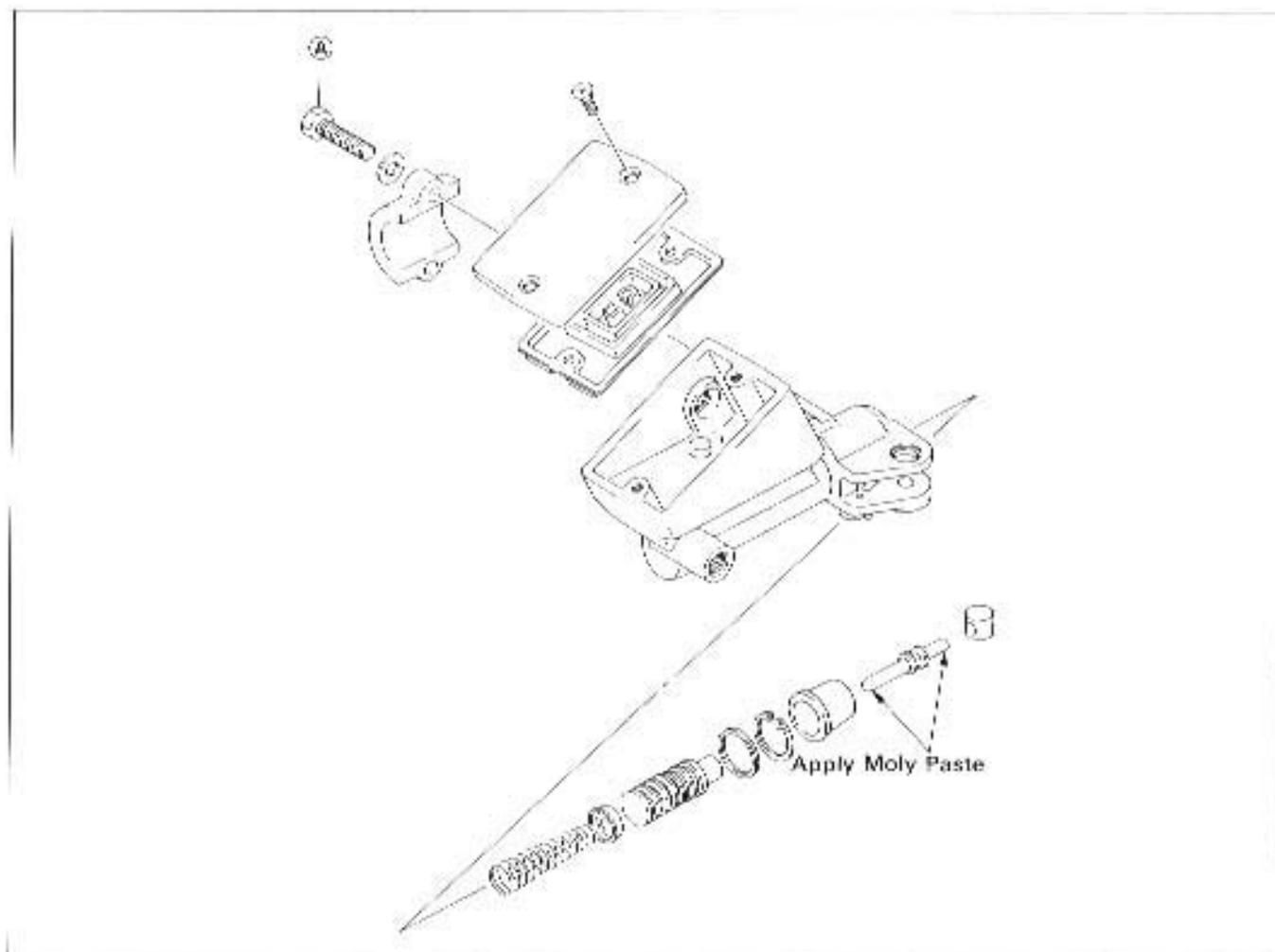

### REMOVAL

- Remove the clutch switch (starter interlock switch).
- Place a rag underneath the union bolt on the master cylinder to catch any spilled drops of brake fluid. Unscrew the union bolt and disconnect the clutch hose from the master cylinder.

#### CAUTION:

Completely wipe off any brake fluid adhering to any parts of motorcycle. The fluid reacts chemically with paint, plastics, rubber materials, etc. and will damage them severely.

- Remove the clutch master cylinder by removing its clamp bolts.



### DISASSEMBLY AND REASSEMBLY

Disassemble and reassemble the clutch master cylinder in the same manner of the front brake master cylinder.

(Refer to pages 6-9 and 6-10 for details.)

# SERVICING INFORMATION

## CONTENTS

<i>TROUBLESHOOTING</i> .....	7- 1
<i>WIRING DIAGRAM</i> .....	7- 8
<i>WIRE HARNESS, CABLE AND HOSE ROUTING</i> .....	7-14
<i>SPECIAL TOOLS</i> .....	7-26
<i>TIGHTENING TORQUE</i> .....	7-29
<i>SERVICE DATA</i> .....	7-31

## TROUBLESHOOTING

## ENGINE

Complaint	Symptom and possible causes	Remedy
Engine will not start, or is hard to start.	<p><b>Compression too low</b></p> <ol style="list-style-type: none"> <li>1. Valve clearance out of adjustment.</li> <li>2. Worn valve guides or poor seating of valves.</li> <li>3. Valves mistiming.</li> <li>4. Piston rings excessively worn.</li> <li>5. Worn-down cylinder bores.</li> <li>6. Starter motor cranks but too slowly.</li> <li>7. Poor seating of spark plugs.</li> </ol> <p><b>Plugs not sparking</b></p> <ol style="list-style-type: none"> <li>1. Fouled spark plugs.</li> <li>2. Wet spark plugs.</li> <li>3. Defective ignition coil.</li> <li>4. Open or short in high-tension cords.</li> <li>5. Defective signal generator of ignition unit.</li> </ol> <p><b>No fuel reaching the carburetors</b></p> <ol style="list-style-type: none"> <li>1. Clogged fuel tank vent hose.</li> <li>2. Clogged or defective fuel/cock.</li> <li>3. Defective carburetor float valve.</li> <li>4. Clogged fuel hose or fuel filter.</li> </ol>	<p>Adjust. Repair, or replace. Adjust. Replace. Replace, or rebore. Consult "electrical complaints". Retighten.</p> <p>Clean. Clean and dry. Replace. Replace. Replace.</p> <p>Clean or replace. Clean or replace. Replace. Clean or replace.</p>
Engine stalls easily.	<ol style="list-style-type: none"> <li>1. Fouled spark plugs.</li> <li>2. Defective signal generator or ignitor unit.</li> <li>3. Clogged fuel hose.</li> <li>4. Clogged jets in carburetors.</li> <li>5. Valve clearance out of adjustment.</li> </ol>	<p>Clean. Replace. Clean. Clean. Adjust.</p>
Noisy engine.	<p><b>Excessive valve chatter</b></p> <ol style="list-style-type: none"> <li>1. Valve clearance too large.</li> <li>2. Weakened or broken valve springs.</li> <li>3. Worn down rocker arm or rocker arm shaft.</li> </ol> <p><b>Noise appears to come from pistons.</b></p> <ol style="list-style-type: none"> <li>1. Pistons or cylinders worn down.</li> <li>2. Combustion chambers fouled with carbon.</li> <li>3. Piston pins or piston pin bore worn.</li> <li>4. Piston rings or ring grooves worn.</li> </ol> <p><b>Noise seems to come from timing chain</b></p> <ol style="list-style-type: none"> <li>1. Stretched chain.</li> <li>2. Worn sprockets.</li> <li>3. Tension adjuster not working.</li> </ol> <p><b>Noise seems to come from clutch.</b></p> <ol style="list-style-type: none"> <li>1. Worn splines of countershaft or hub.</li> <li>2. Worn teeth of clutch plates.</li> <li>3. Distorted clutch plates, driven and drive.</li> <li>4. Worn clutch release bearing.</li> <li>5. Clutch dampers weakened.</li> </ol>	<p>Adjust. Replace. Replace.</p> <p>Replace. Clean. Replace. Replace.</p> <p>Replace. Replace. Repair, or replace.</p> <p>Replace. Replace. Replace. Replace. Replace the primary driven gear.</p>

Complaint	Symptom and possible causes	Remedy
<b>Noisy engine.</b>	<p><b>Noise seems to come from crankshaft</b></p> <ol style="list-style-type: none"> <li>1. Rattling bearings due to wear.</li> <li>2. Big-end bearings worn and burnt.</li> <li>3. Journal bearings worn and burnt.</li> <li>4. Thrust clearance too large.</li> </ol> <p><b>Noise seems to come from transmission</b></p> <ol style="list-style-type: none"> <li>1. Gears worn or rubbing.</li> <li>2. Badly worn splines.</li> <li>3. Primary gears worn or rubbing.</li> <li>4. Badly worn bearings.</li> </ol>	<p>Replace. Replace. Replace. Replace the thrust bearing</p> <p>Replace. Replace. Replace. Replace.</p>
<b>Slipping clutch.</b>	<ol style="list-style-type: none"> <li>1. Clutch control out of adjustment or loss of play.</li> <li>2. Weakened clutch springs.</li> <li>3. Worn or distorted pressure plate.</li> <li>4. Distorted clutch plates, driven and drive.</li> </ol>	<p>Adjust. Replace. Replace. Replace.</p>
<b>Dragging clutch.</b>	<ol style="list-style-type: none"> <li>1. Clutch control out of adjustment or too much play.</li> <li>2. Some clutch springs weakened while others are not.</li> <li>3. Distorted pressure plate or clutch plate.</li> </ol>	<p>Adjust. Replace. Replace.</p>
<b>Transmission will not shift</b>	<ol style="list-style-type: none"> <li>1. Broken gearshift cam.</li> <li>2. Distorted gearshift forks.</li> <li>3. Worn gearshift pawl.</li> </ol>	<p>Replace. Replace. Replace.</p>
<b>Transmission will not shift back</b>	<ol style="list-style-type: none"> <li>1. Broken return spring on shift shaft.</li> <li>2. Shift shaft is rubbing or sticky.</li> <li>3. Distorted or worn gearshift forks.</li> </ol>	<p>Replace. Repair. Replace.</p>
<b>Transmission jumps out of gear.</b>	<ol style="list-style-type: none"> <li>1. Worn shifting gears on driveshaft or countershaft.</li> <li>2. Distorted or worn gearshift forks.</li> <li>3. Weakened stopper spring on gearshift stopper.</li> <li>4. Worn gearshift pawl.</li> </ol>	<p>Replace. Replace. Replace. Replace.</p>
<b>Engine idles poorly.</b>	<ol style="list-style-type: none"> <li>1. Valve clearance out of adjustment.</li> <li>2. Poor seating of valves.</li> <li>3. Defective valve guides.</li> <li>4. Worn rocker arms or arm shafts.</li> <li>5. Spark plug gaps too wide.</li> <li>6. Defective ignition coil.</li> <li>7. Defective signal generator or ignitor unit.</li> <li>8. Float-chamber fuel level out of adjustment in carburetors.</li> <li>9. Clogged jets or imbalance of carburetors.</li> </ol>	<p>Adjust. Replace. Replace. Replace. Adjust or replace. Replace. Replace. Adjust. Clean or adjust.</p>
<b>Engine runs poorly in high speed range.</b>	<ol style="list-style-type: none"> <li>1. Valve springs weakened.</li> <li>2. Worn cams or rocker arms.</li> <li>3. Valve timing out of adjustment.</li> <li>4. Spark plug gaps too narrow.</li> <li>5. Ignition not advanced sufficiently due to poorly working timing advance circuit.</li> <li>6. Defective ignition coil.</li> <li>7. Defective signal generator or ignitor unit.</li> <li>8. Float-chamber fuel level too low.</li> <li>9. Clogged air cleaner element.</li> <li>10. Clogged fuel hose, resulting in inadequate fuel supply to carburetors.</li> </ol>	<p>Replace. Replace. Adjust Adjust. Replace.</p> <p>Replace. Replace. Adjust. Clean. Clean, and prime.</p>



Complaint	Symptom and possible causes	Remedy
<b>Dirty or heavy exhaust smoke.</b>	<ol style="list-style-type: none"> <li>1. Too much engine oil in the engine.</li> <li>2. Worn piston rings or cylinders.</li> <li>3. Worn valve guides.</li> <li>4. Cylinder walls scored or scuffed.</li> <li>5. Worn valves stems.</li> <li>6. Defective stem seal.</li> <li>7. Worn oil ring side rails.</li> </ol>	Check with level window, drain out excess oil. Replace. Replace. Rebore or replace. Replace. Replace. Replace.
<b>Engine lacks power.</b>	<ol style="list-style-type: none"> <li>1. Loss of valve clearance.</li> <li>2. Weakened valve springs.</li> <li>3. Valve timing out of adjustment.</li> <li>4. Worn piston rings or cylinders.</li> <li>5. Poor seating of valves.</li> <li>6. Fouled spark plug.</li> <li>7. Spark plug gaps incorrect.</li> <li>8. Clogged jets in carburetors.</li> <li>9. Float-chamber fuel level out of adjustment.</li> <li>10. Clogged air cleaner element.</li> <li>11. Carburetor balancing screw loose.</li> <li>12. Sucking air from intake pipe.</li> <li>13. Too much engine oil.</li> </ol>	Adjust. Replace. Adjust. Replace. Repair. Clean or replace. Adjust or replace. Clean. Adjust. Clean. Retighten. Retighten or replace. Drain out excess oil.
<b>Engine overheats.</b>	<ol style="list-style-type: none"> <li>1. Heavy carbon deposit on piston crowns</li> <li>2. Not enough oil in the engine.</li> <li>3. Defective oil pump or clogged oil circuit.</li> <li>4. Fuel level too low in float chambers.</li> <li>5. Sucking air from intake pipes.</li> <li>6. Use incorrect engine oil.</li> </ol>	Clean. Add oil. Replace or clean. Adjust. Retighten or replace. Change.

## CARBURETOR

Complaint	Symptom and possible causes	Remedy
<b>Trouble with starting.</b>	<ol style="list-style-type: none"> <li>1. Starter jet is clogged.</li> <li>2. Starter pipe is clogged.</li> <li>3. Air leaking from a joint between starter body and carburetor.</li> <li>4. Air leaking from carburetor's joint or vacuum gauge joint.</li> <li>5. Starter plunger is not operating properly.</li> </ol>	Clean. Clean. Check starter body and carburetor for tightness, adjust and replace gasket. Check and adjust. Check and adjust.
<b>Idling or low-speed trouble</b>	<ol style="list-style-type: none"> <li>1. Pilot jet, pilot air jet are clogged or loose.</li> <li>2. Air leaking from carburetor's joint, vacuum gauge joint, or starter.</li> <li>3. Pilot outlet or bypass is clogged</li> <li>4. Starter plunger is not fully closed.</li> </ol>	Check and clean. Check and clean. Check and clean. Check and adjust.
<b>Medium-or high speed trouble</b>	<ol style="list-style-type: none"> <li>1. Main jet or main air jet is clogged.</li> <li>2. Needle jet is clogged.</li> <li>3. Throttle valve is not operating properly.</li> <li>4. Fuel filter is clogged.</li> </ol>	Check and clean. Check and clean. Check throttle valve for operation. Check and clean.
<b>Overflow and fuel level fluctuations.</b>	<ol style="list-style-type: none"> <li>1. Needle valve is worn or damaged.</li> <li>2. Spring in needle valve is broken.</li> <li>3. Float is not working properly.</li> <li>4. Foreign matter has adhered to needle valve.</li> <li>5. Fuel level is too high or low.</li> </ol>	Replace. Replace. Check and adjust. Clean. Adjust float height.

## ELECTRICAL

Complaint	Symptom and possible causes	Remedy
No sparking or poor sparking.	<ol style="list-style-type: none"> <li>1. Defective ignition coil.</li> <li>2. Defective spark plugs.</li> <li>3. Defective signal generator or ignitor unit.</li> </ol>	Replace. Replace. Replace.
Spark plugs soon become fouled with carbon.	<ol style="list-style-type: none"> <li>1. Mixture too rich.</li> <li>2. Idling speed set to high.</li> <li>3. Incorrect gasoline.</li> <li>4. Dirty element in air cleaner.</li> <li>5. Spark plugs too cold.</li> </ol>	Adjust carburetors. Adjust carburetors. Change. Clean. Replace with hot type plugs.
Spark plugs become fouled too soon.	<ol style="list-style-type: none"> <li>1. Worn piston rings.</li> <li>2. Piston or cylinders worn.</li> <li>3. Excessive clearance of valve stems in valve guides.</li> <li>4. Worn stem oil seal.</li> </ol>	Replace. Replace. Replace. Replace.
Spark plug electrodes overheat or burn	<ol style="list-style-type: none"> <li>1. Spark plugs too hot.</li> <li>2. The engine overheats</li> <li>3. Spark plugs loose.</li> <li>4. Mixture too lean.</li> </ol>	Replace with cold type plugs. Tune up. Retighten. Adjust carburetors.
Generator does not charge	<ol style="list-style-type: none"> <li>1. Open or short lead wires, or loose lead connections.</li> <li>2. Shorted, grounded or open generator coils.</li> <li>3. Shorted or punctured regulator and rectifier.</li> <li>4. Brushes not seating properly on slip ring in rotor.</li> </ol>	Repair or replace or retighten. Replace. Replace. Repair, or replace.
Generator does charge, but charging rate is below the specification.	<ol style="list-style-type: none"> <li>1. Lead wires tend to get shorted or open-circuited or loosely connected at terminals.</li> <li>2. Grounded or open-circuited stator coils of generator.</li> <li>3. Defective regulator and rectifier.</li> <li>4. Not enough electrolyte in the battery.</li> <li>5. Defective cell plates in the battery.</li> </ol>	Repair, or retighten. Replace. Replace. Add distilled water to the upper level. Replace the battery.
Generator overcharges	<ol style="list-style-type: none"> <li>1. Internal short-circuit in the battery.</li> <li>2. Resistor element in the regulator damaged or defective.</li> <li>3. Regulator poorly grounded.</li> </ol>	Replace the battery. Replace. Clean and tighten ground connection
Unstable charging.	<ol style="list-style-type: none"> <li>1. Lead wire insulation frayed due to vibration, resulting in intermittent shorting.</li> <li>2. Generator internally shorted.</li> <li>3. Defective regulator and rectifier.</li> </ol>	Repair, or replace. Replace. Replace.
Starter button is not effective	<ol style="list-style-type: none"> <li>1. Battery run down.</li> <li>2. Defective switch contacts.</li> <li>3. Brushes not seating properly on commutator in starter motor</li> <li>4. Defective starter relay.</li> </ol>	Repair, or replace. Replace. Repair, or replace. Replace.

## BATTERY

Symptom	Probable cause	Remedy
"Sulfation", acidic white powdery substance or spots on surfaces of cell plates.	<ol style="list-style-type: none"> <li>1. Not enough electrolyte.</li> <li>2. Battery case is cracked.</li> <li>3. Battery has been left in a run-down condition for a long time.</li> <li>4. Contaminated electrolyte (Foreign matter has entered the battery and become mixed with the electrolyte).</li> </ol>	<p>Add distilled water, if the battery has not been damaged and "sulfation" has not advanced too far, and recharge.</p> <p>Replace the battery.</p> <p>Replace the battery.</p> <p>If "sulfation" has not advanced too far, try to restore the battery by replacing the electrolyte, recharging it fully with the battery detached from the motorcycle and then adjusting electrolyte S.G.</p>
Battery runs down quickly	<ol style="list-style-type: none"> <li>1. The charging method is not correct.</li> <li>2. Cell plates have lost much of their active material as a result of overcharging.</li> <li>3. A short-circuit condition exists within the battery due to excessive accumulation of sediments caused by the high electrolyte S.G.</li> <li>4. Electrolyte S.G. is too low.</li> <li>5. Contaminated electrolyte.</li> <li>6. Battery is too old.</li> </ol>	<p>Check the generator, regulator/rectifier and circuit connections, and make necessary adjustments to obtain specified charging operation.</p> <p>Replace the battery, and correct the charging system.</p> <p>Replace the battery.</p> <p>Recharge the battery fully and adjust electrolyte S.G.</p> <p>Replace the electrolyte, recharge the battery and then adjust S.G.</p> <p>Replace the battery.</p>
Reversed battery polarity.	The battery has been connected the wrong way round in the system, so that it is being charged in the reverse direction.	Replace the battery and be sure to connect the battery properly.
Battery "sulfation".	<ol style="list-style-type: none"> <li>1. Charging rate too low or too high. (When not in use batteries should be recharged at least once a month to avoid sulfation.)</li> <li>2. Battery electrolyte excessive or insufficient, or its specific gravity too high or too low.</li> <li>3. The battery left unused for too long in cold climate.</li> </ol>	<p>Replace the battery.</p> <p>Keep the electrolyte up to the prescribed level, or adjust the S.G. by consulting the battery maker's directions.</p> <p>Replace the battery, if badly sulfated.</p>
Battery discharges too rapidly.	<ol style="list-style-type: none"> <li>1. Dirty container top and sides.</li> <li>2. Impurities in the electrolyte or electrolyte S.G. is too high.</li> </ol>	<p>Clean.</p> <p>Change the electrolyte by consulting the battery maker's direction.</p>

## CHASSIS

Complaint	Symptom and possible causes	Remedy
Heavy steering	<ol style="list-style-type: none"> <li>1. Steering stem nut overtightened.</li> <li>2. Broken bearing in steering stem.</li> <li>3. Distorted steering stem.</li> <li>4. Not enough pressure in tires.</li> <li>5. Incorrect mounting of steering damper.</li> </ol>	Adjust. Replace. Replace. Adjust. Adjust.
Wobbly handlebars	<ol style="list-style-type: none"> <li>1. Loss of balance between right and left front forks.</li> <li>2. Distorted front fork.</li> <li>3. Distorted front axle or crooked tire.</li> <li>4. Oil leakage of steering damper.</li> </ol>	Replace. Repair, or replace. Replace. Replace.
Wobbly front wheel.	<ol style="list-style-type: none"> <li>1. Distorted wheel rim.</li> <li>2. Worn front wheel bearings.</li> <li>3. Defective or incorrect tire.</li> <li>4. Loose nut on axle.</li> <li>5. Incorrect front fork oil.</li> </ol>	Replace. Replace. Replace. Retighten. Adjust.
Front suspension too soft	<ol style="list-style-type: none"> <li>1. Weakened springs.</li> <li>2. Not enough fork oil.</li> </ol>	Replace. Refill.
Front suspension too stiff	<ol style="list-style-type: none"> <li>1. Fork oil too viscous.</li> <li>2. Too much fork oil.</li> </ol>	Replace. Drain excess oil.
Noisy front suspension.	<ol style="list-style-type: none"> <li>1. Not enough fork oil.</li> <li>2. Loose nuts on suspension.</li> </ol>	Refill. Retighten.
Wobbly rear wheel.	<ol style="list-style-type: none"> <li>1. Distorted wheel rim.</li> <li>2. Worn rear wheel bearings or swingarm bearings.</li> <li>3. Defective or incorrect tire.</li> <li>4. Worn swingarm and rear cushion related bearings.</li> <li>5. Loose nuts or bolts on rear suspensions.</li> </ol>	Replace. Replace. Replace. Replace. Retighten.
Rear suspension too soft.	<ol style="list-style-type: none"> <li>1. Weakened shock absorber spring.</li> <li>2. Rear suspension adjuster improperly set.</li> <li>3. Oil leakage of shock absorber.</li> <li>4. Gas leakage of shock absorber.</li> </ol>	Replace. Adjust. Replace. Replace.
Rear suspension too stiff	<ol style="list-style-type: none"> <li>1. Rear suspension adjuster improperly set.</li> <li>2. Shock absorber shaft bent.</li> <li>3. Swingarm bent.</li> <li>4. Worn swingarm and rear cushion related bearings.</li> </ol>	Adjust. Replace. Replace. Replace.
Noisy rear suspension.	<ol style="list-style-type: none"> <li>1. Loose nuts or bolts on rear suspension.</li> <li>2. Worn swingarm and rear cushion related bearings.</li> </ol>	Retighten. Replace.

## BRAKES

Complaint	Symptom and possible causes	Remedy
<b>Insufficient brake power</b>	<ol style="list-style-type: none"> <li>1. Leakage of brake fluid from hydraulic system.</li> <li>2. Worn pads.</li> <li>3. Oil adhesion on engaging surface of pads.</li> <li>4. Worn disc.</li> <li>5. Air in hydraulic system.</li> </ol>	<p>Repair, or replace.            Replace.            Clean disc and pads.            Replace.            Bleed air.</p>
<b>Brake squeaking.</b>	<ol style="list-style-type: none"> <li>1. Carbon adhesion on pad surface.</li> <li>2. Tilted pad.</li> <li>3. Damaged wheel bearing.</li> <li>4. Loose front-wheel axle or rear-wheel axle.</li> <li>5. Worn pads.</li> <li>6. Foreign material in brake fluid.</li> <li>7. Clogged return port of master cylinder.</li> </ol>	<p>Repair surface with sandpaper.            Modify pad fitting.            Replace.            Tighten to specified torque.            Replace.            Replace brake fluid.            Disassemble and clean master cylinder.</p>
<b>Excessive brake lever stroke.</b>	<ol style="list-style-type: none"> <li>1. Air in hydraulic system.</li> <li>2. Insufficient brake fluid.</li> <li>3. Improper quality of brake fluid.</li> </ol>	<p>Bleed air.            Replenish fluid to specified level; bleed air.            Replace with correct fluid.</p>
<b>Leakage of brake fluid</b>	<ol style="list-style-type: none"> <li>1. Insufficient tightening of connection joints.</li> <li>2. Cracked hose.</li> <li>3. Worn piston and/or cup.</li> </ol>	<p>Tighten to specified torque.            Replace.            Replace piston and/or cup.</p>

# WIRING DIAGRAM

FOR GENERAL, ENGLAND, NORWAY, BELGIUM AND AUSTRALIA MODELS

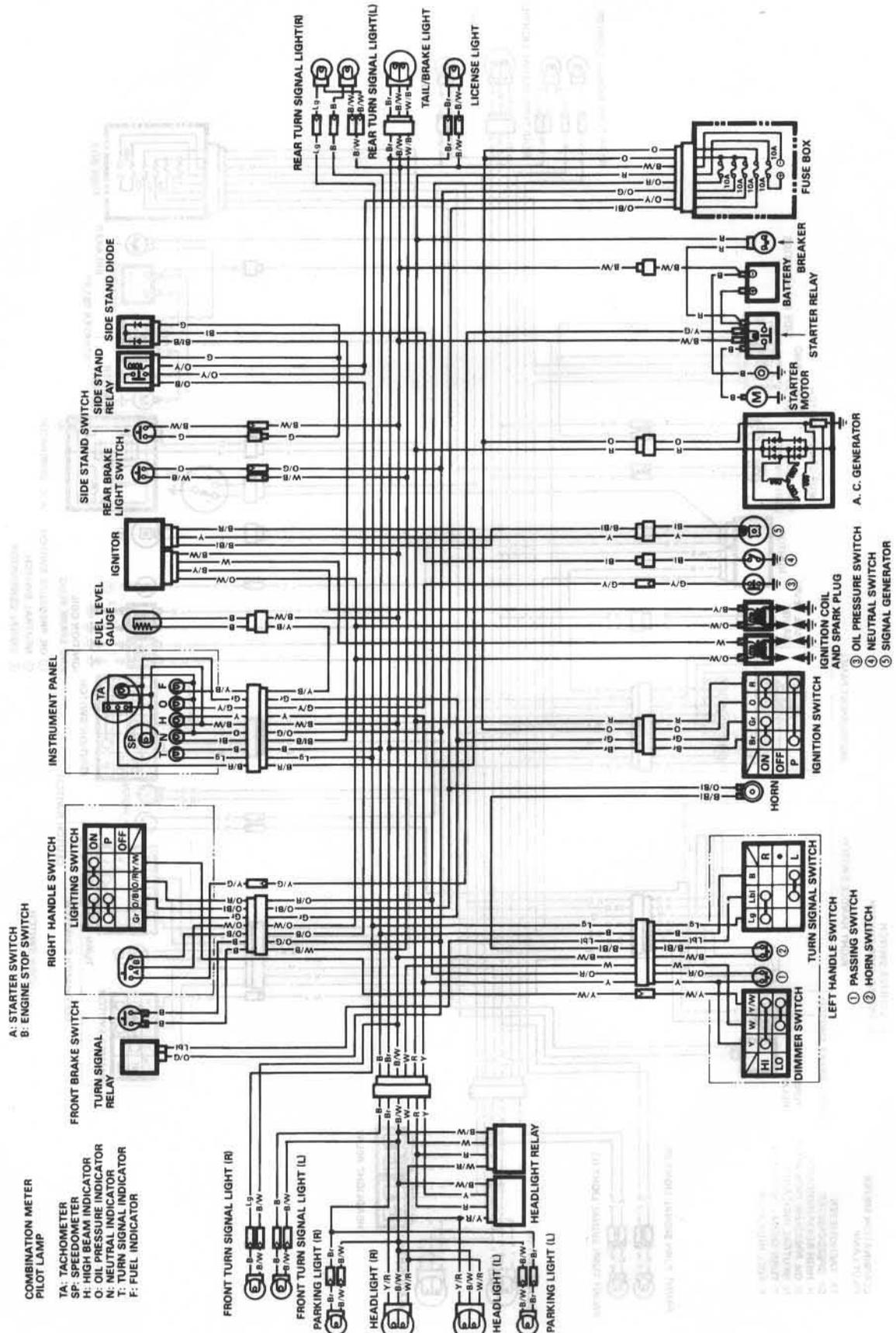

FOR U.S.A. MODEL

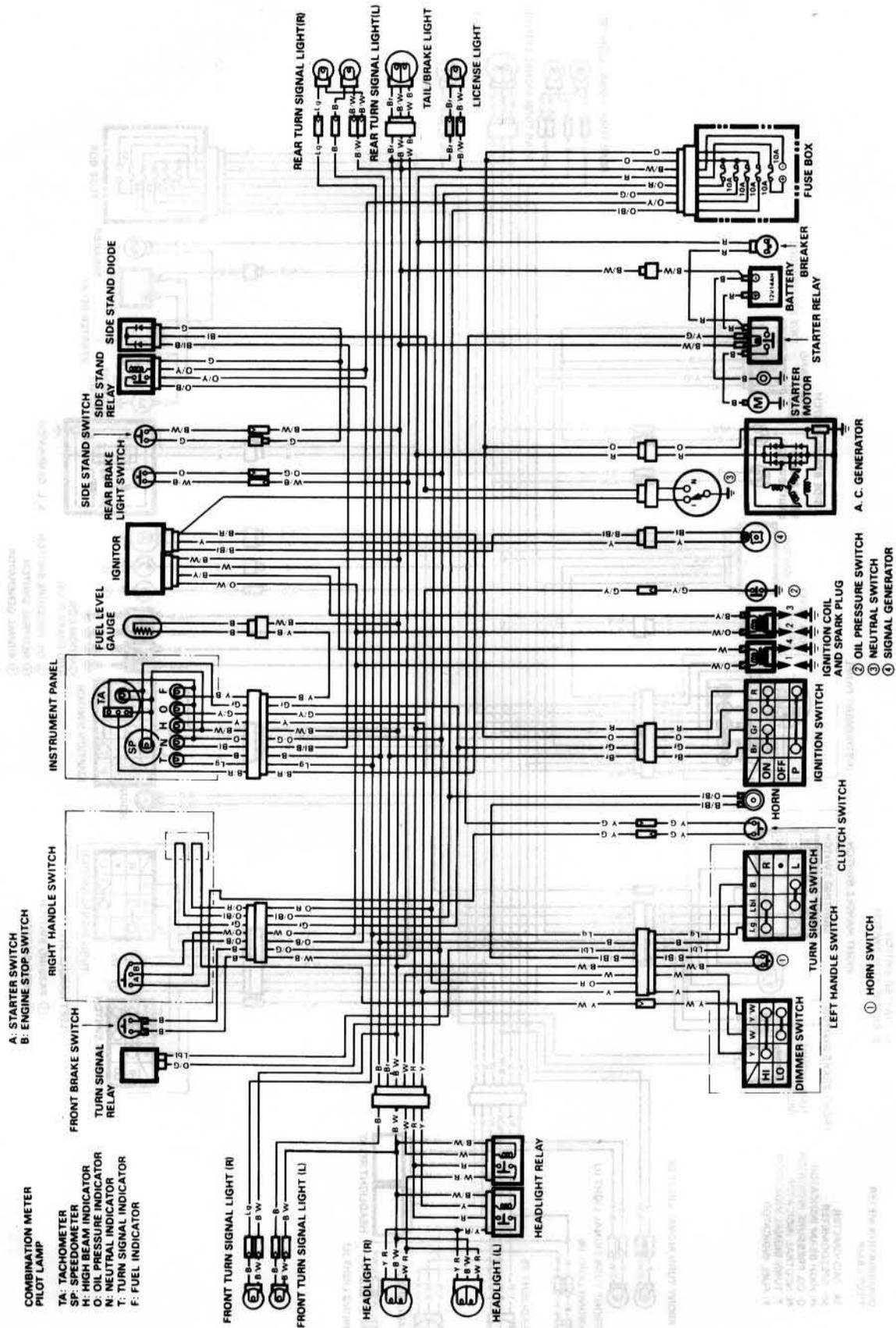

FOR CANADA MODEL

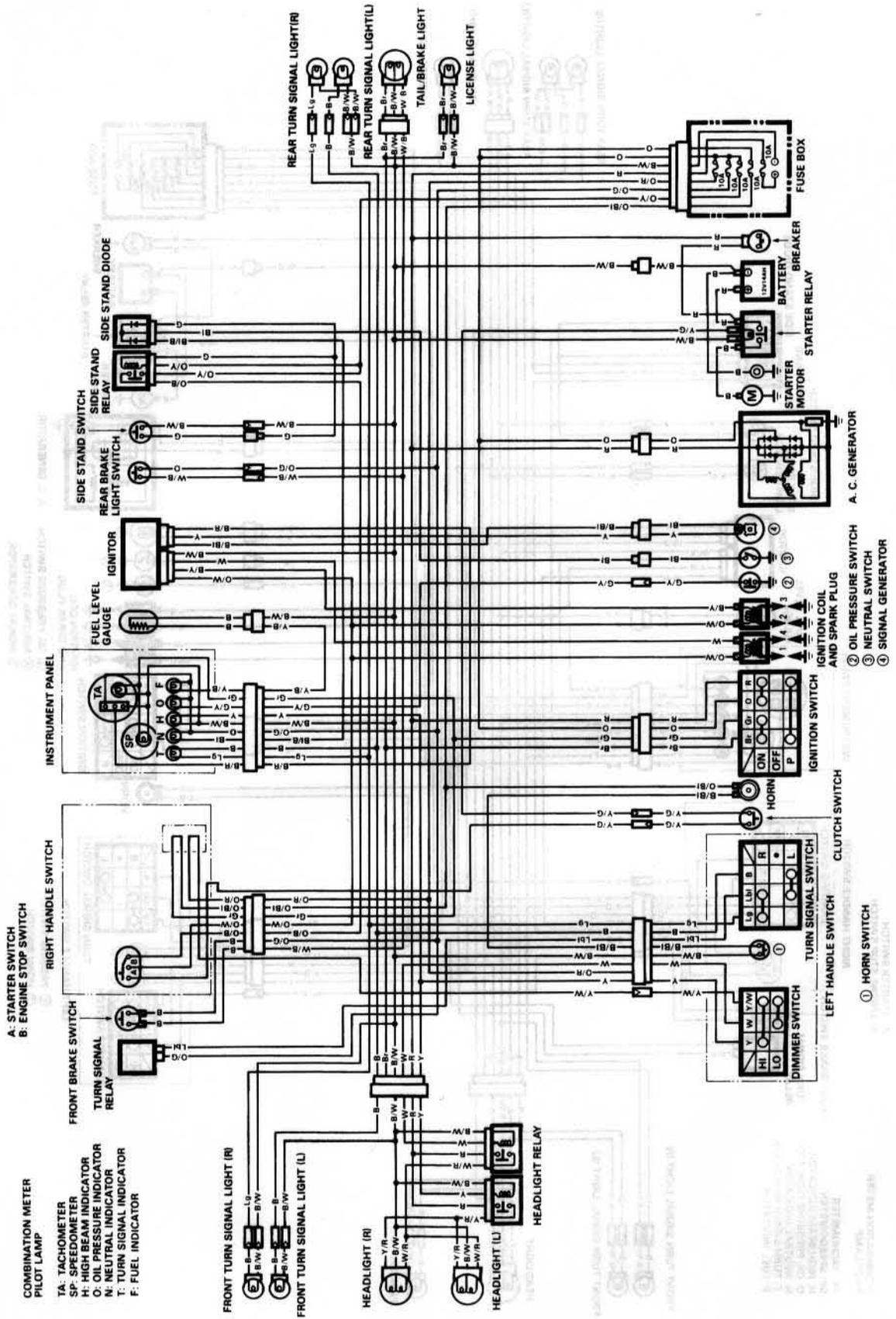



FOR SWITZERLAND MODEL

FOR CANADA MODEL

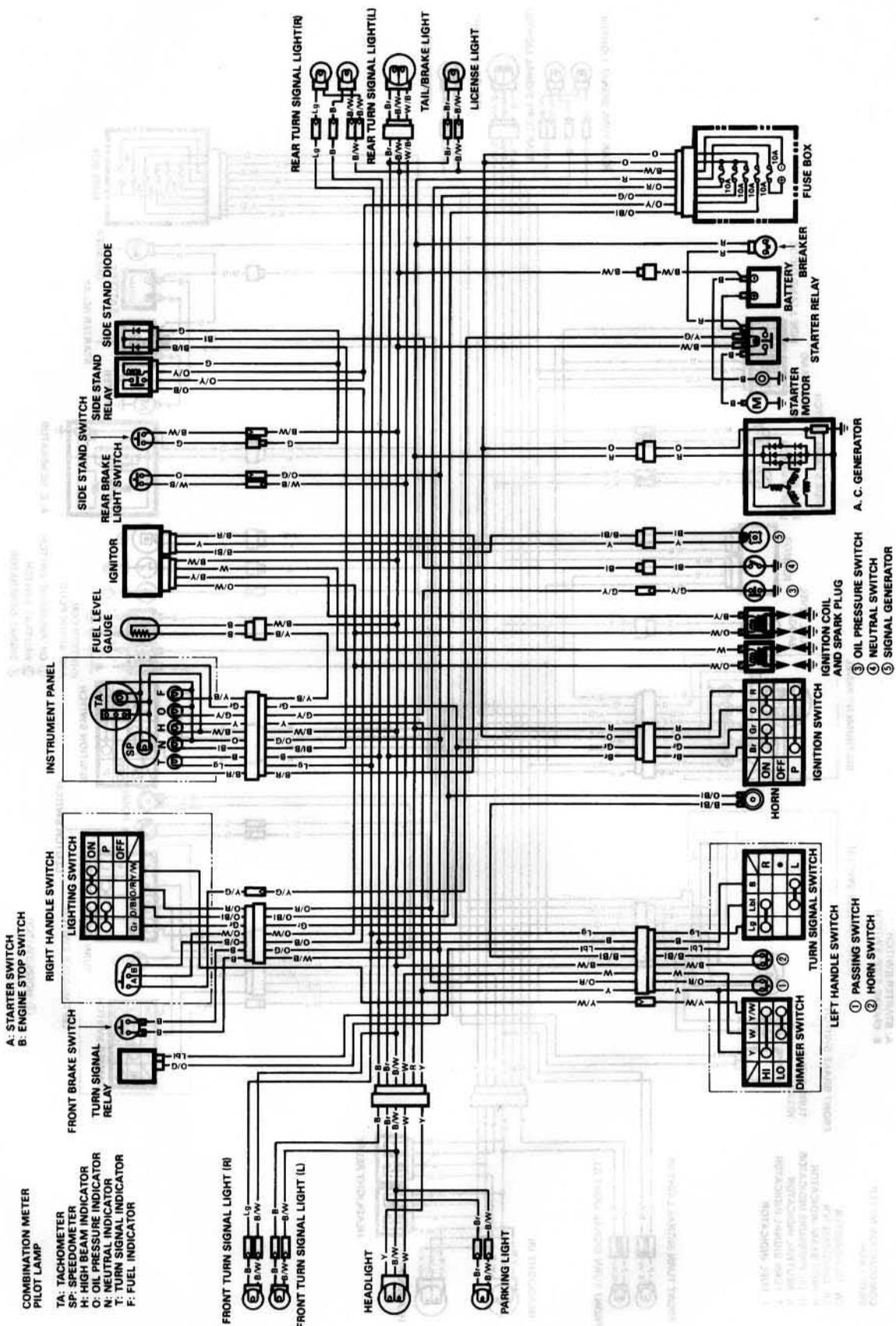

FOR ITALY MODEL

FOR THE OTHER MODELS

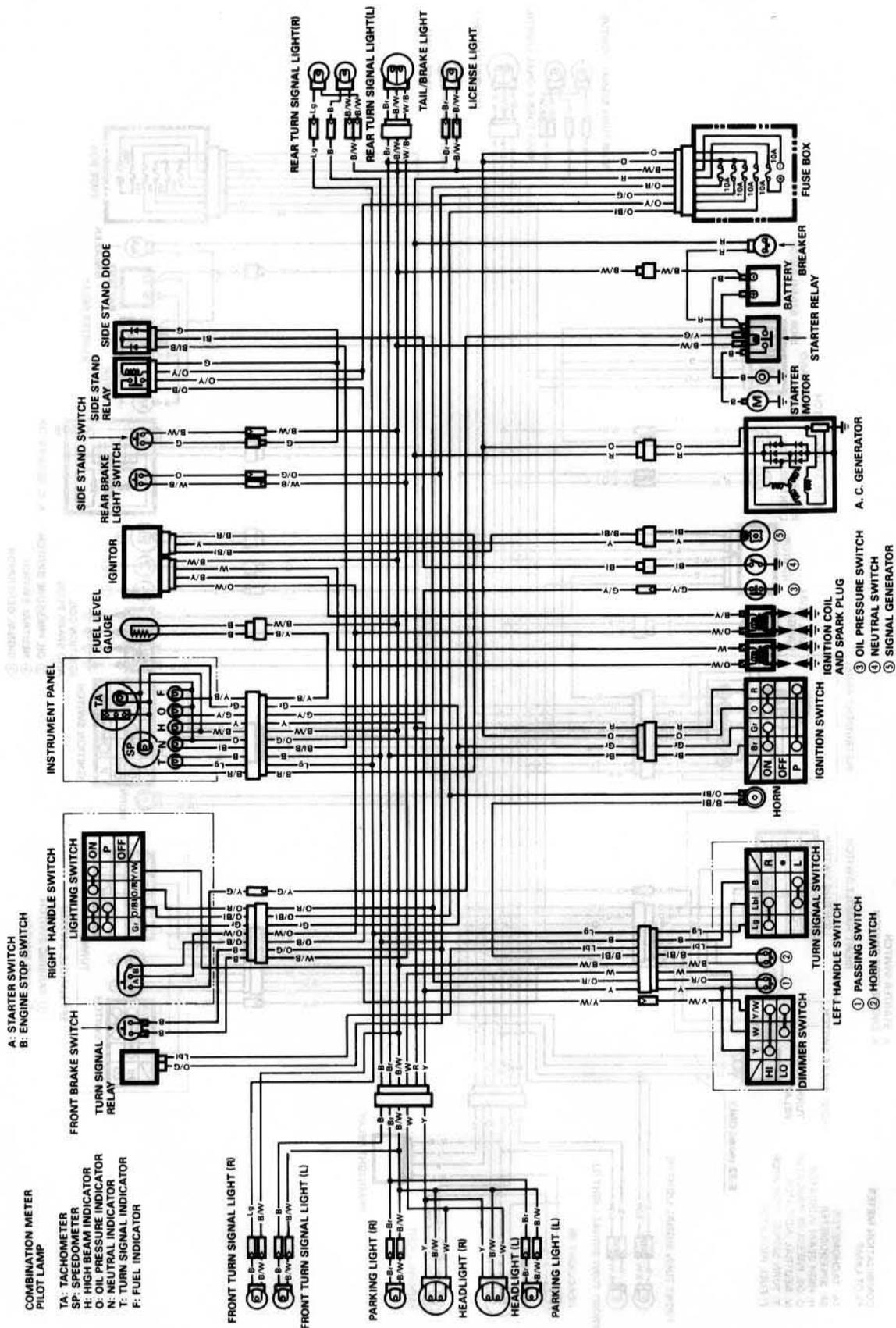



# WIRE HARNESS, CABLE AND HOSE ROUTING

## WIRE ROUTING

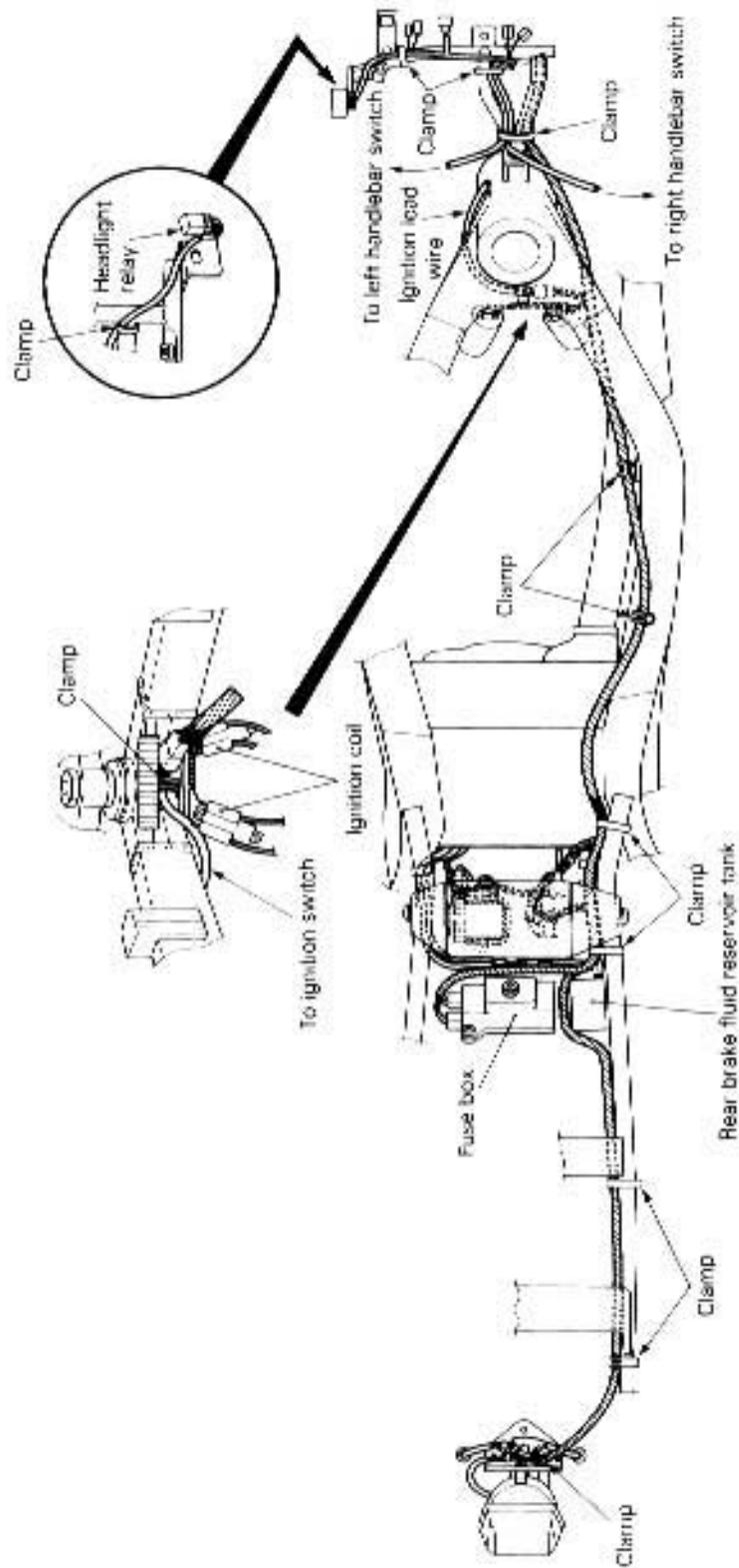

## WIRE ROUTING

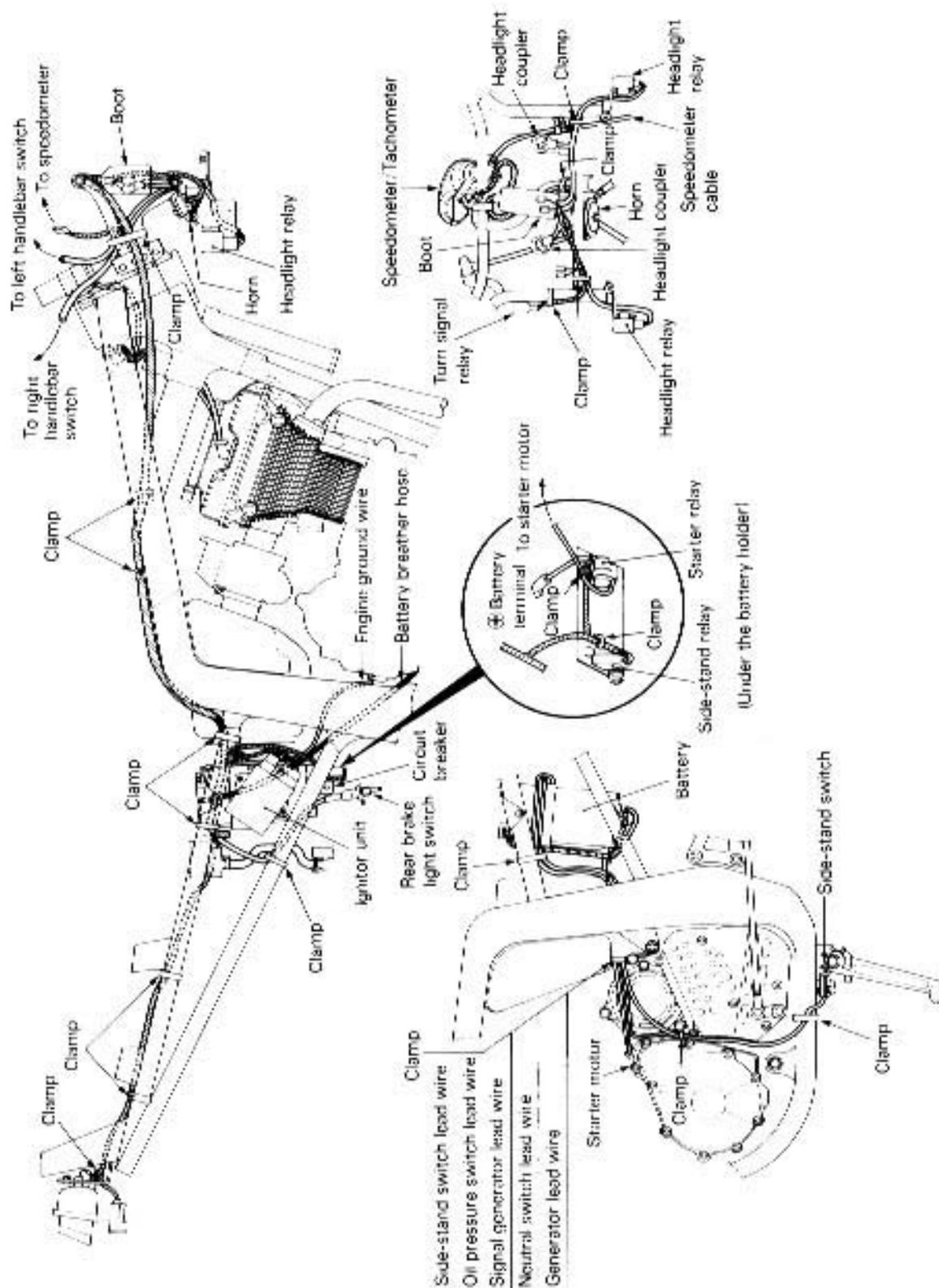

## SPEEDOMETER CABLE ROUTING

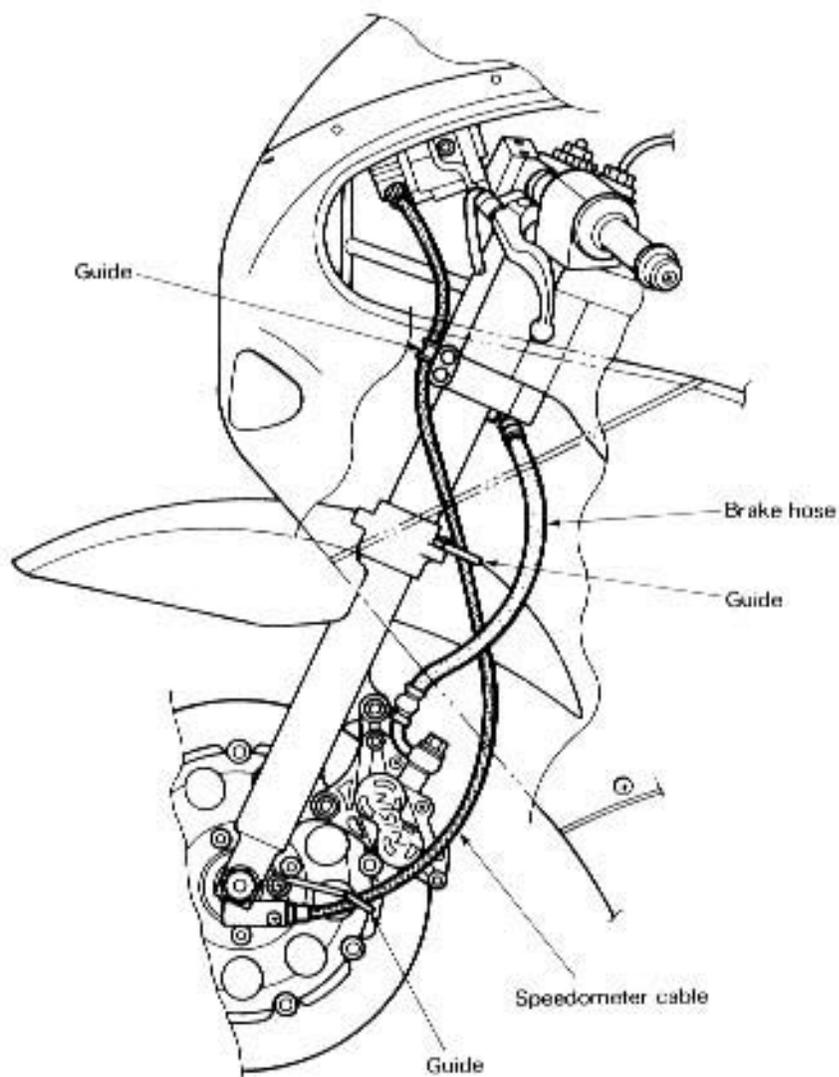

## THROTTLE CABLE ROUTING

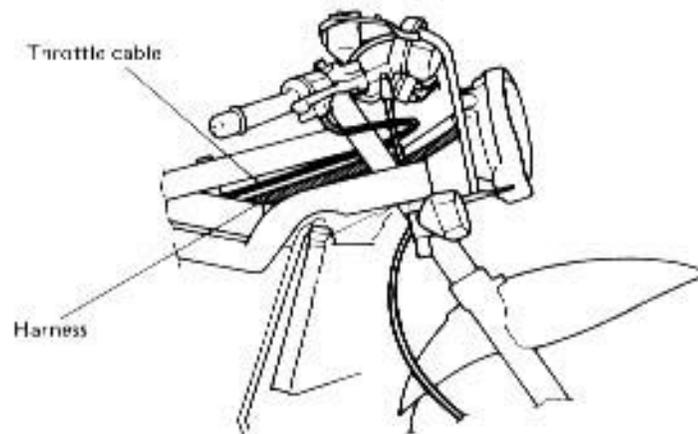
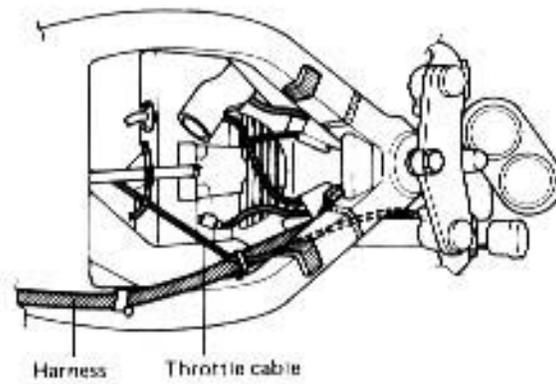
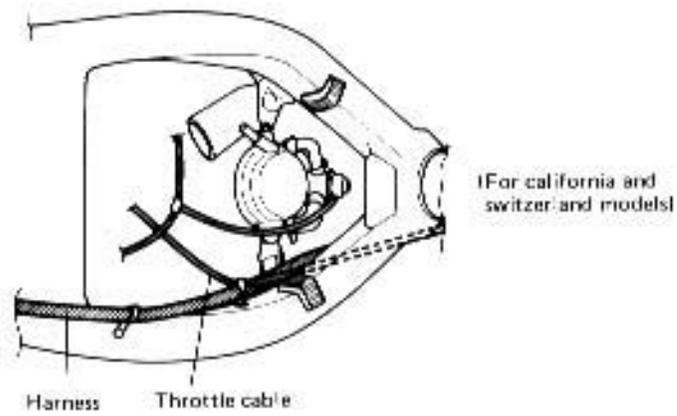

## CLUTCH HOSE ROUTING

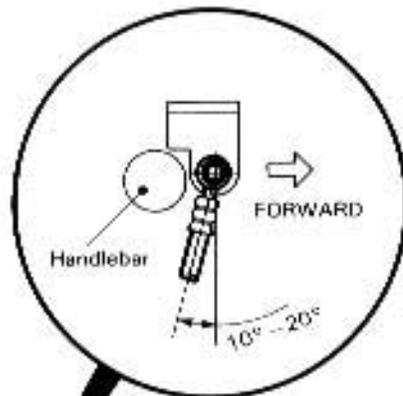

**CAUTION:** Do not twist the clutch hose.

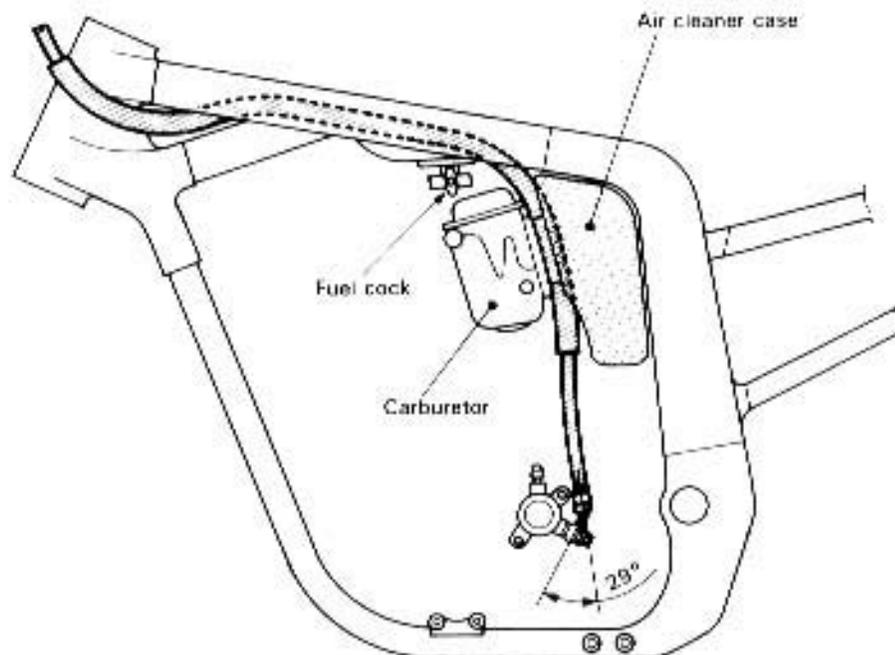
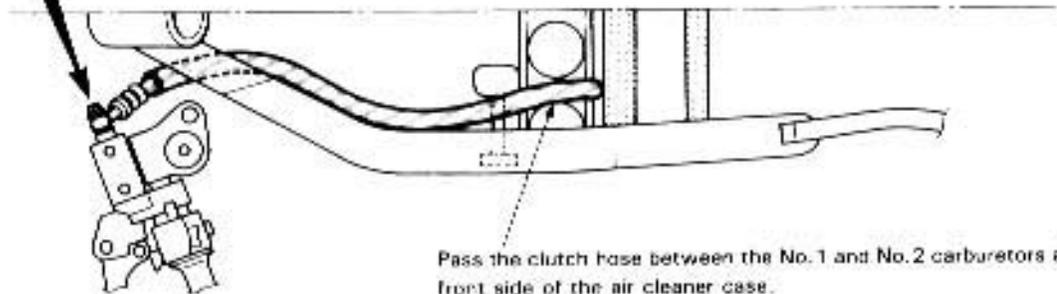



# OIL COOLER HOSE AND AIR CLEANER HOSE ROUTING

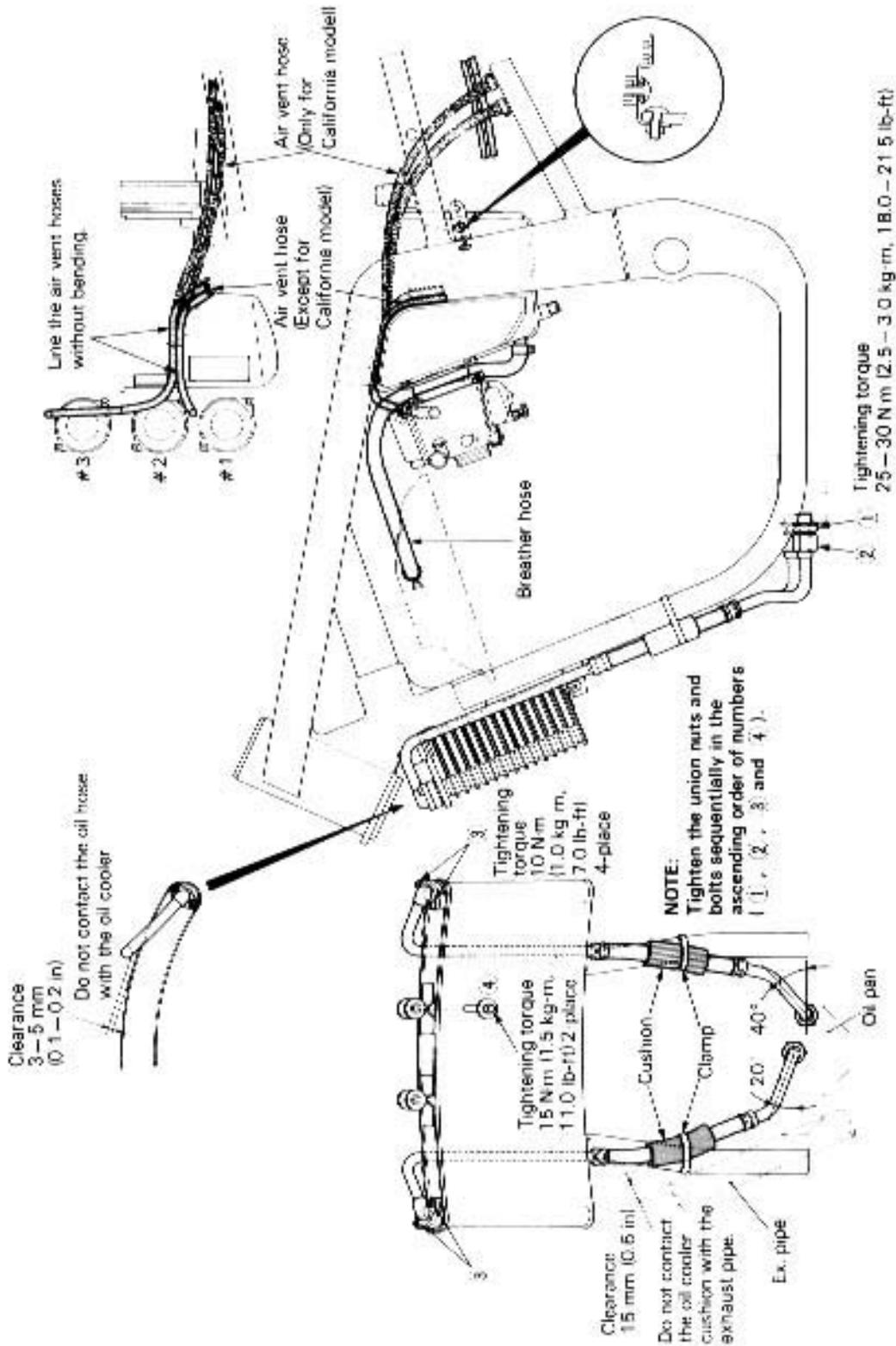

# FRONT BRAKE HOSE ROUTING

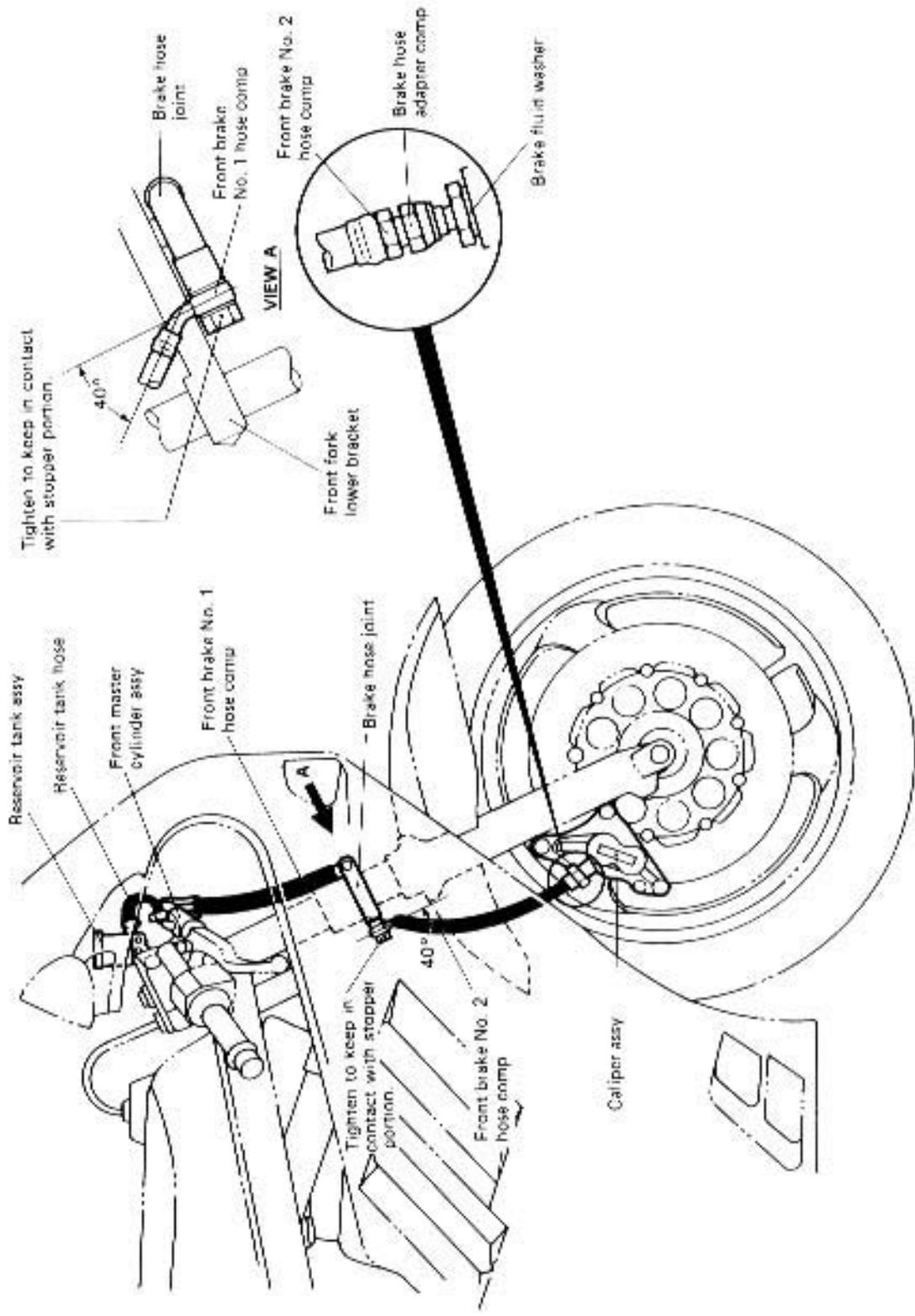

## REAR BRAKE HOSE ROUTING

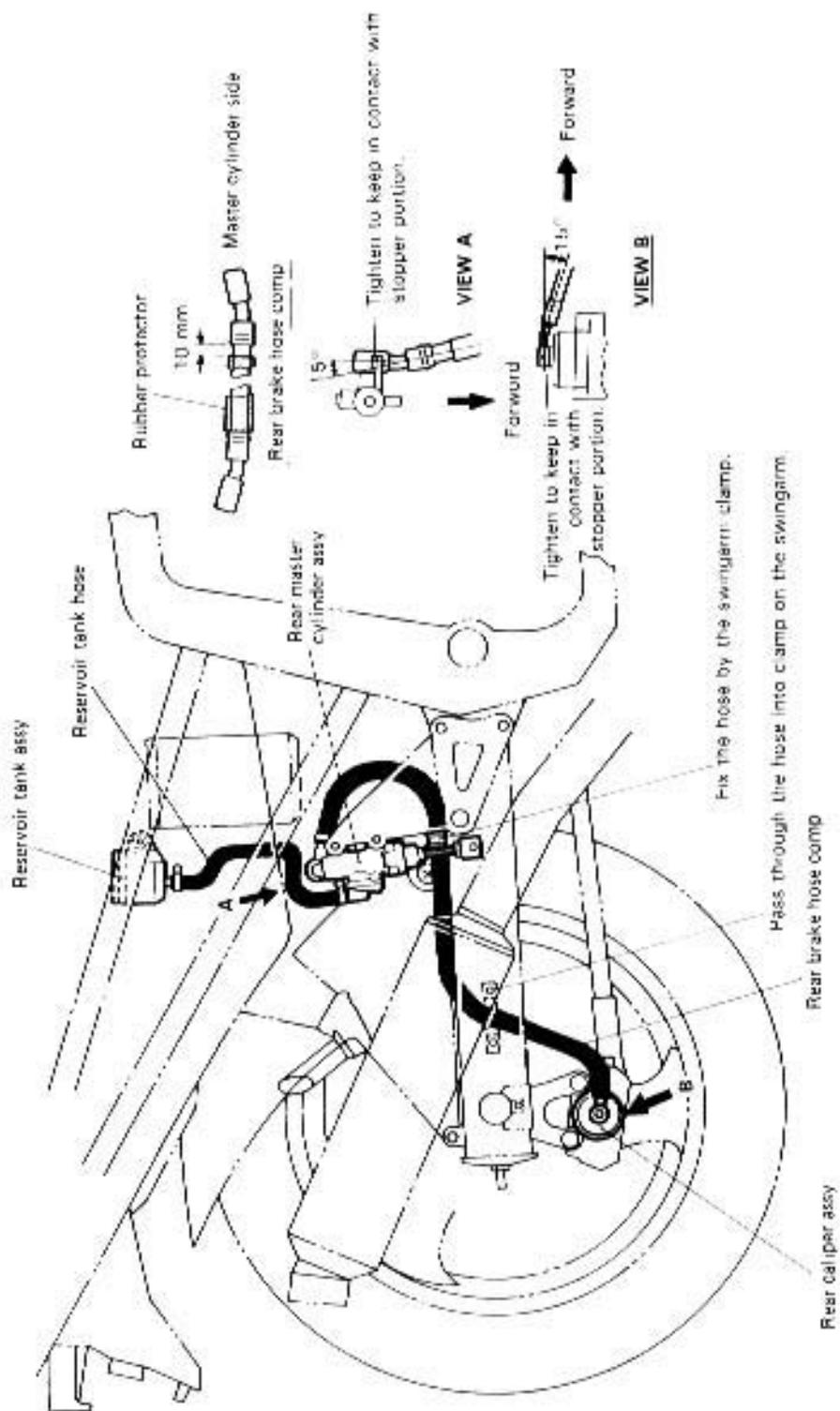

## FUEL HOSE AND FUEL TANK WATER DRAIN HOSE ROUTING

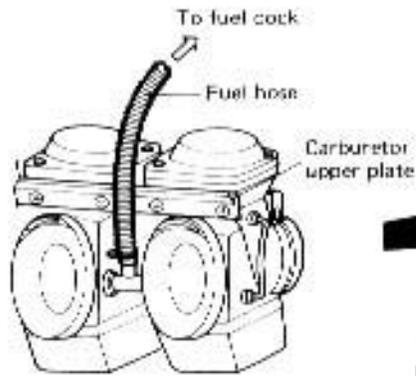

Pass through both fuel hoses behind the carburetor upper plate

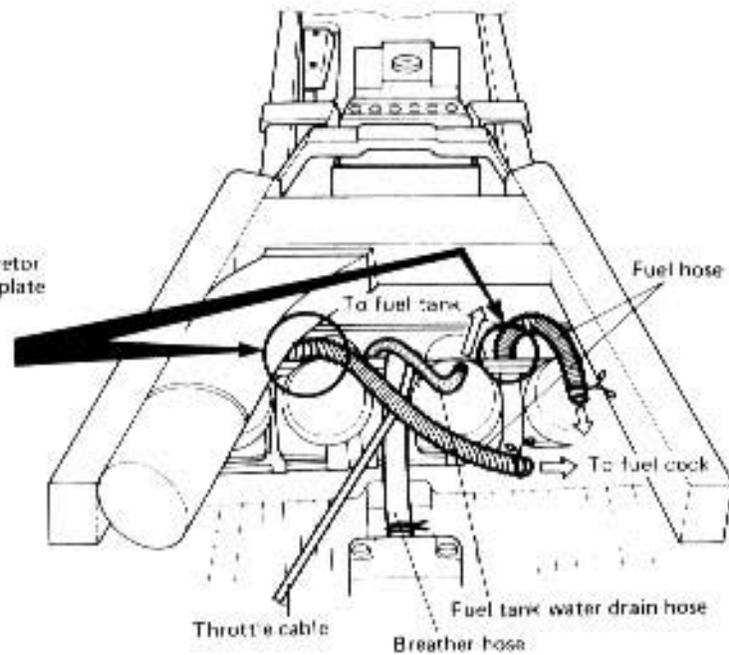

Pass through the LH fuel hose and fuel tank water drain hose above the breather hose and throttle cable

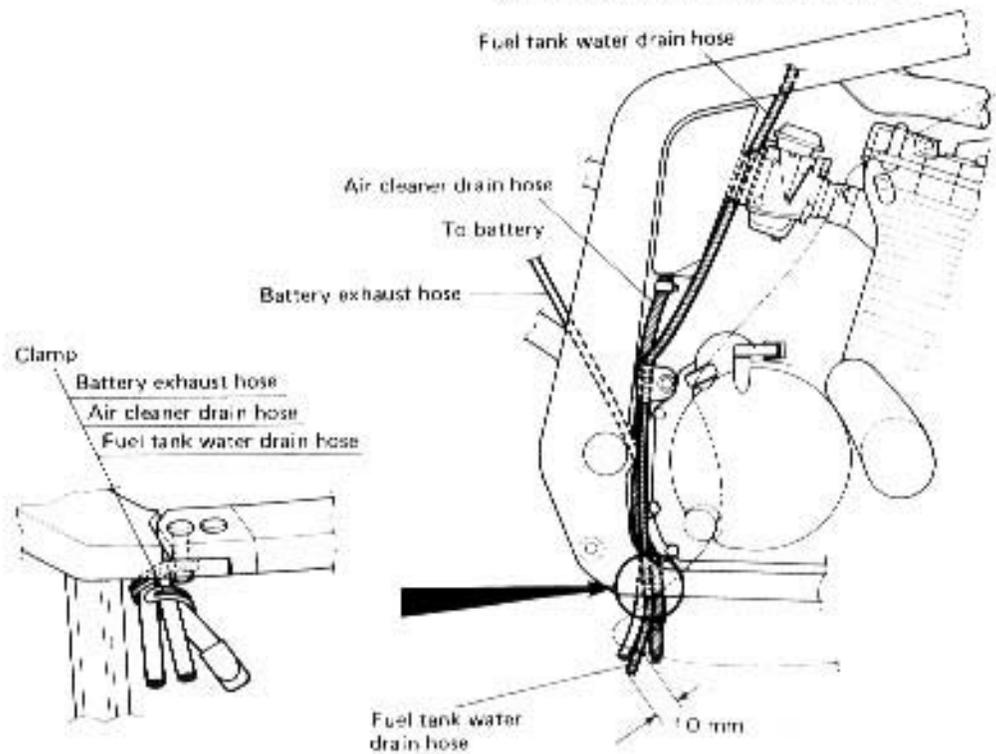

### BATTERY BREATHER ROUTING

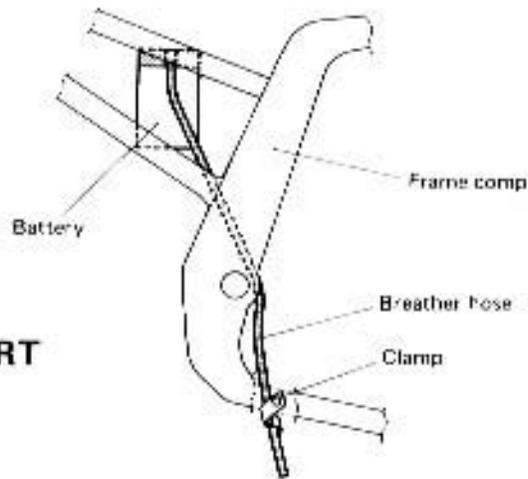

### MUFFLER SUPPORT

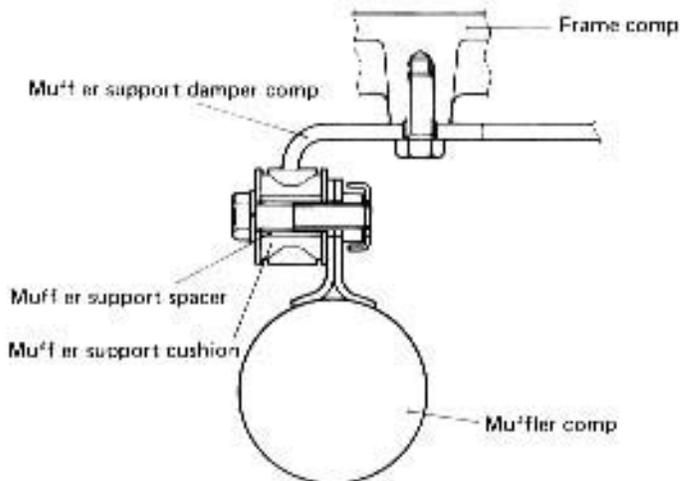

### SEAT LOCK CABLE

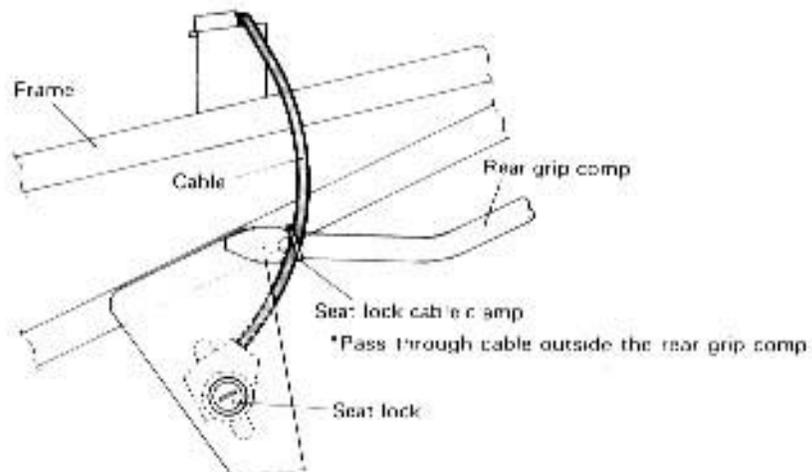

## HIGH TENSION CORD ROUTING (For Switzerland and California models)

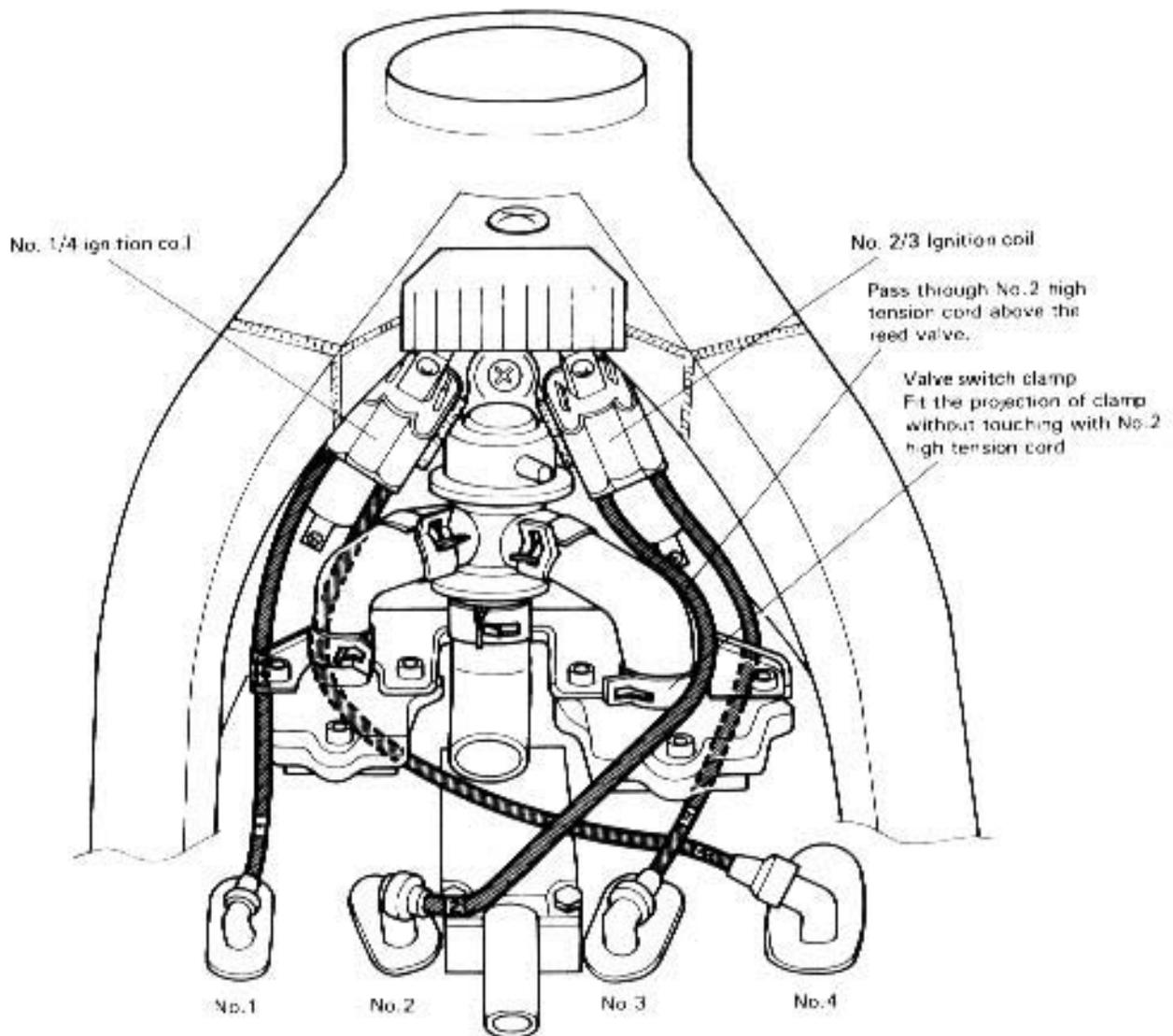

## RESERVOIR TANK HOSE ROUTING

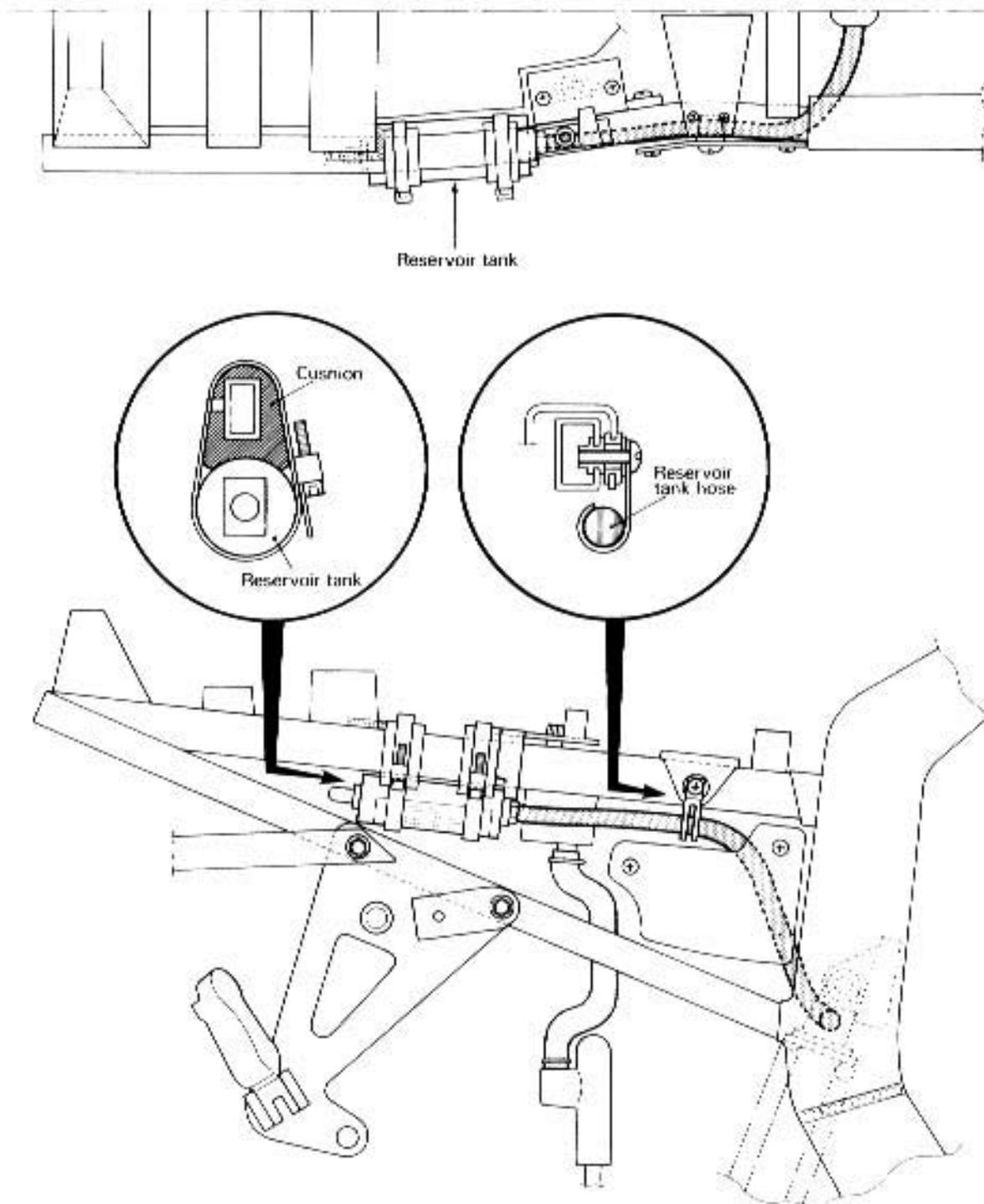

# SPECIAL TOOLS

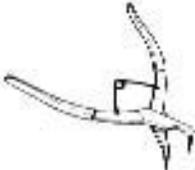
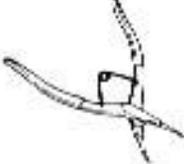
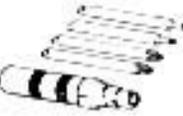
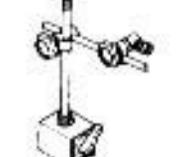
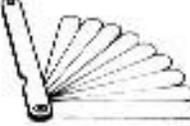
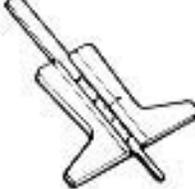
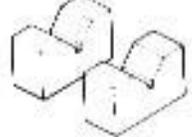
 <p>09900-00401 "L" type hexagon wrench set</p>	 <p>09900-00410 Hexagon bit wrench set</p>	 <p>09900-06105 Snap ring pliers</p>	 <p>09900-06107 Snap ring pliers</p>	 <p>09900-06108 Snap ring pliers</p>
 <p>09900-09003 Impact driver set</p>	 <p>09900-20102 Vernier calipers</p>	 <p>09900-20202 Micrometer (25 - 50 mm)</p>	 <p>09900-20204 Micrometer (75 - 100 mm)</p>	 <p>09900-20205 Micrometer (0 - 25 mm)</p>
 <p>09900-20503 Cylinder bore gauge set</p>	 <p>09900-20602 Dial gauge (1/1000 mm, 1mm)</p>	 <p>09900-20605 Dial calipers</p>	 <p>09900-20608 Dial gauge (1/100 mm, 10 mm)</p>	 <p>09900-20701 Magnetic stand</p>
 <p>09900-20702 Micrometer stand</p>	 <p>09900-20803 Thickness gauge</p>	 <p>09900-20805 Tire depth gauge</p>	 <p>09900-21304 V-block (100 mm)</p>	 <p>09900-22301 Plastigauge</p>
 <p>09900-22403 Small bore gauge (18 - 35 mm)</p>	 <p>09900-25002 Pocket tester</p>	 <p>09900-28106 Electro tester</p>	 <p>09900-28403 Hydrometer</p>	 <p>09910-20118 Cor rod holder</p>
 <p>09910-80811 Universal clamp wrench</p>	 <p>09911-73730 5 mm "L" type hexagon wrench</p>	 <p>09911-74510 Long socket wrench</p>	 <p>09912-34510 Cylinder disassembler</p>	 <p>09913-13121 Carburetor balancer gauge</p>

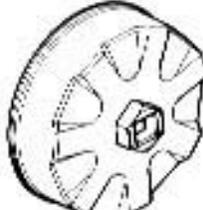
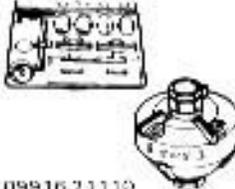
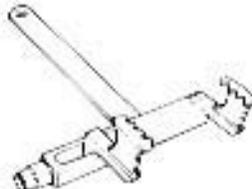

				
09913-50121 Oil seal remover	09913-60910 Bearing puller (40-60 mm)	09913-81510 Bearing puller	09913-75520 Bearing installer	09914-24510 T-handle
				
09914-25811 6 mm "T" type hexagon wrench	09914-79910 Bearing and oil seal installer	09915-40810 Oil filter wrench	09915-63210 Compression gauge adaptor	09915-64510 Compression gauge
				
09915-74510 Oil pressure gauge	09915-74540 Oil pressure gauge adaptor	09915-77330 Meter (for high pressure)	09916-14510 Valve lifter	09916-14910 Valve lifter attachment
				
09916-24311 Solid pilot (N-100-5 G)	09916-21110 Valve seat cutter set Valve seat cutter head N-121 N-122 * See page 3-27	09916-34541 Reamer handle	09916-34570 Valve guide reamer (5.0 mm)	09916-34580 Valve guide reamer (10.8 mm)
				
09916-44310 Valve guide remover/ installer	09916-74521 Piston holder handle	09916-74540 Piston holder	09916-84510 Tweezers	09917-14910 Tapet adjust driver
				
09920-34610 Starter clutch holder	09920-34820 Clutch pressure plate holder	09920-50710 Clutch sleeve hub holder	09923-74510 Bearing puller	09924-84510 Bearing installer set

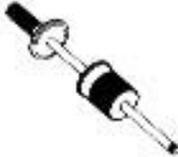
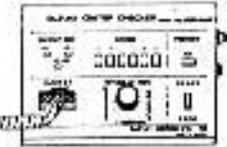
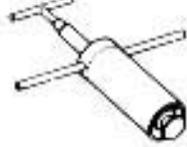
 <p>09930-11910 Torx wrench</p>	 <p>09930-30102 Sliding shaft</p>	 <p>09930-33720 Rotor remover</p>	 <p>09931-84411 Ignitor checker (Digital type)</p>	 <p>09940-14511 Steering stem nut wrench</p>
 <p>09940-50112 Front fork oil seal installer</p>	 <p>09940-54820 Front fork disassembler</p>	 <p>09941-34513 Steering race installer</p>	 <p>09941-44510 Swingarm bearing remover</p>	 <p>09941-50110 Bearing remover</p>
 <p>09941-58010 60 mm socket wrench</p>	 <p>09941-74910 Steering bearing installer</p>	 <p>09941-84510 Bearing remover</p>	 <p>09943-74111 Fork oil level gauge</p>	

\* : Not available in U.S.A.

**TIGHTENING TORQUE****ENGINE**

ITEM	N·m	kg·m	lb·ft
Cylinder head cover bolt	13 - 15	1.3 - 1.5	9.5 - 11.0
Cylinder head cover union bolt	15 - 17	1.5 - 1.7	11.0 - 12.5
Cylinder head nut	35 - 40	3.5 - 4.0	25.5 - 29.0
Cylinder head bolt	8 - 12	0.8 - 1.2	6.0 - 8.5
Cylinder base nut	7 - 11	0.7 - 1.1	5.0 - 8.0
Cylinder stud bolt	13 - 16	1.3 - 1.6	9.5 - 11.5
Valve clearance adjuster lock nut	9 - 11	0.9 - 1.1	6.5 - 8.0
Camshaft journal holder bolt	8 - 12	0.8 - 1.2	6.0 - 8.5
Cam sprocket bolt	24 - 26	2.4 - 2.6	17.5 - 19.0
Rocker arm shaft set bolt	8 - 10	0.8 - 1.0	6.0 - 7.0
Oil hose mounting bolt (Cylinder head side)	8 - 12	0.8 - 1.2	6.0 - 8.5
Oil hose mounting bolt (Crankcase side)	8 - 12	0.8 - 1.2	6.0 - 8.5
Cam chain tensioner mounting bolt	6 - 8	0.6 - 0.8	4.5 - 6.0
Cam chain tensioner spring holder bolt	30 - 45	3.0 - 4.5	21.5 - 32.5
Cam chain idler mounting bolt	8 - 12	0.8 - 1.2	6.0 - 8.5
Cam chain guide mounting bolt	4 - 7	0.4 - 0.7	3.0 - 5.0
Conrod bearing cap nut	49 - 53	4.9 - 5.3	35.5 - 38.0
Starter clutch mounting bolt	143 - 157	14.3 - 15.7	103.5 - 113.5
Signal generator bolt	25 - 35	2.5 - 3.5	18.0 - 25.5
Crankcase bolt (6 mm)	9 - 13	0.9 - 1.3	6.5 - 9.5
(8 mm)	20 - 24	2.0 - 2.4	14.5 - 17.5
Oil pump mounting bolt	8 - 12	0.8 - 1.2	6.0 - 8.5
Oil drain plug	20 - 25	2.0 - 2.5	14.5 - 18.0
Oil pan bolt	12 - 16	1.2 - 1.6	8.5 - 11.5
Gearshift cam stopper bolt	15 - 23	1.5 - 2.3	11.0 - 16.5
Clutch sleeve hub nut	140 - 160	14.0 - 16.0	101.5 - 115.5
Clutch diaphragm spring holder nut	90 - 110	9.0 - 11.0	65.0 - 79.5
Exhaust pipe bolt	18 - 28	1.8 - 2.8	13.0 - 20.0
Muffler mounting bolt (Front side)	18 - 28	1.8 - 2.8	13.0 - 20.0
Muffler mounting bolt (Rear side)	22 - 35	2.2 - 3.5	16.0 - 25.5
Engine sprocket nut	100 - 130	10.0 - 13.0	72.5 - 94.0
Engine mounting (L:55 mm) bolt	50 - 60	5.0 - 6.0	36.0 - 43.5
(L:150 mm and 178 mm)	70 - 88	7.0 - 8.8	50.5 - 63.5

## CHASSIS

ITEM	N-m	kg-m	lb-ft
Steering stem head nut	50 - 80	5.0 - 8.0	36.0 - 58.0
Front fork upper clamp bolt	22 - 35	2.2 - 3.5	16.0 - 25.5
Front fork lower clamp bolt	22 - 35	2.2 - 3.5	16.0 - 25.5
Front fork cap bolt	15 - 30	1.5 - 3.0	11.0 - 21.5
Front fork damper rod bolt	34 - 46	3.4 - 4.6	24.5 - 33.5
Front axle	85 - 115	8.5 - 11.5	61.5 - 83.0
Front axle pinch bolt	18 - 28	1.8 - 2.8	13.0 - 20.0
Handlebar holder mounting bolt	50 - 60	5.0 - 6.0	36.0 - 43.5
Handlebar holder mounting nut	22 - 35	2.2 - 3.5	16.0 - 25.5
Front brake caliper mounting bolt	27 - 43	2.7 - 4.3	19.5 - 31.0
Front brake caliper housing bolt	20 - 25	2.0 - 2.5	14.5 - 18.0
Front brake pad mounting bolt	15 - 20	1.5 - 2.0	11.0 - 14.5
Front brake master cylinder bolt	5 - 8	0.5 - 0.8	3.5 - 6.0
Brake hose union bolt (Cylinder & Caliper)	20 - 25	2.0 - 2.5	14.5 - 18.0
Air bleeder valve (Front & Rear)	6 - 9	0.6 - 0.9	4.5 - 6.5
Front and rear disc bolt	15 - 25	1.5 - 2.5	11.0 - 18.0
Front footrest bracket mounting bolt	27 - 43	2.7 - 4.3	19.5 - 31.0
Swingarm pivot nut	85 - 115	8.5 - 11.5	61.5 - 83.0
Front footrest nut	35 - 55	3.5 - 5.5	25.5 - 40.0
Rear shock absorber mounting nut (Upper & Lower)	40 - 60	4.0 - 6.0	29.0 - 43.5
Rear cushion level/rod mounting nut	110 - 160	11.0 - 16.0	79.5 - 115.5
Rear brake caliper mounting bolt	18 - 28	1.8 - 2.8	13.0 - 20.0
Rear brake caliper housing bolt	30 - 36	3.0 - 3.6	21.5 - 26.0
Rear torque link nut (Front & Rear)	22 - 34	2.2 - 3.4	16.0 - 24.5
For E-03,28 and 33	18 - 28	1.8 - 2.8	13.0 - 20.0
Rear brake master cylinder mounting bolt	18 - 28	1.8 - 2.8	13.0 - 20.0
Rear brake rod lock nut	18 - 28	1.8 - 2.8	13.0 - 20.0
Rear axle nut	85 - 115	8.5 - 11.5	61.5 - 83.0
Rear sprocket nut	48 - 72	4.8 - 7.2	35.0 - 52.0

**SERVICE DATA****VALVE + GUIDE**

Unit: mm (in)

ITEM	STANDARD		LIMIT
Valve diam.	IN.	28.5 (1.12)	—
	EX.	25 (1.0)	—
Valve lift	IN.	8.8 (0.35)	—
	EX.	8.2 (0.32)	—
Valve clearance (when cold)	IN.	0.10 – 0.15 (0.004 – 0.006)	—
	EX.	0.18 – 0.23 (0.007 – 0.009)	—
Valve guide to valve stem clearance	IN.	0.020 – 0.047 (0.0008 – 0.0019)	0.35 (0.014)
	EX.	0.040 – 0.067 (0.0016 – 0.0026)	0.35 (0.014)
Valve guide I.D.	IN. & EX.	5.000 – 5.012 (0.1969 – 0.1973)	—
Valve stem O.D.	IN.	4.965 – 4.980 (0.1955 – 0.1961)	—
	EX.	4.945 – 4.960 (0.1947 – 0.1953)	—
Valve stem runout	IN. & EX.	—	0.05 (0.002)
Valve head thickness	IN. & EX.	—	0.5 (0.02)
Valve stem end length	IN. & EX.	—	2.5 (0.10)
Valve seat width	IN. & EX.	0.9 – 1.1 (0.035 – 0.043)	—
Valve head radial runout	IN. & EX.	—	0.03 (0.001)
Valve spring free length (IN. & EX.)	INNER	—	35.0 (1.38)
	OUTER	—	37.8 (1.49)
Valve spring tension (IN. & EX.)	INNER	5.3 – 6.5 kg (11.7 – 14.3 lbs) at length 28 mm (1.1 in)	—
	OUTER	13.1 – 15.1 kg (28.9 – 33.3 lbs) at length 31.5 mm (1.2 in)	—

**CAMSHAFT – CYLINDER HEAD**

Unit: mm (in)

ITEM	STANDARD		LIMIT
Cam height	IN.	33.878 – 33.918 (1.3338 – 1.3354)	33.580 (1.3220)
	EX.	33.533 – 33.573 (1.3202 – 1.3218)	33.240 (1.3087)
Camshaft journal oil clearance	IN. & EX.	0.032 – 0.066 (0.0013 – 0.0026)	0.150 (0.0059)
Camshaft journal holder I.D.	IN. & EX.	22.012 – 22.025 (0.8666 – 0.8671)	—
Camshaft journal O.D.	IN. & EX.	21.959 – 21.980 (0.8645 – 0.8654)	—
Camshaft runout	IN. & EX.	—	0.10 (0.004)
Cam chain 20-pitch length	—		158.0 (6.22)
Cam chain pin (at arrow "3")	22nd pin		—
Rocker arm I.D.	IN. & EX.	12.000 – 12.018 (0.4724 – 0.4731)	—
Rocker arm shaft O.D.	IN. & EX.	11.973 – 11.984 (0.4714 – 0.4718)	—
Cylinder head distortion	—		0.20 (0.008)

**CYLINDER + PISTON – PISTON RING**

Unit: mm (in)

ITEM	STANDARD		LIMIT
Compression pressure	1 200 – 1 400 kPa 12 – 14 kg/cm <sup>2</sup> 170 – 199 psi		1 000 kPa 10 kg/cm <sup>2</sup> 142 psi
Compression pressure difference	—		200 kPa 2 kg/cm <sup>2</sup> 28 psi
Piston to cylinder clearance	0.050 – 0.060 (0.0020 – 0.0024)		0.120 (0.0047)
Cylinder bore	78.000 – 78.015 (3.0709 – 3.0715)		78.080 (3.0740)
Piston diam.	77.945 – 77.960 (3.0687 – 3.0693) Measure at 15 mm (0.6 in) from the skirt end.		77.880 (3.0661)
Cylinder distortion	—		0.20 (0.008)
Piston ring free end gap	1st N	Approx. 10 (0.39)	8 (0.31)
	2nd N	Approx. 11.5 (0.45)	9.2 (0.36)

Unit: mm (in)

ITEM		STANDARD	LIMIT
Piston ring end gap	1st	0.20 - 0.35 {0.008 - 0.014}	0.7 {0.03}
	2nd	0.35 - 0.50 {0.014 - 0.020}	1.0 {0.04}
Piston ring to groove clearance	1st	—	0.180 {0.007}
	2nd	—	0.150 {0.006}
Piston ring groove width	1st	1.01 - 1.03 {0.040 - 0.041}	—
	2nd	1.01 - 1.03 {0.040 - 0.041}	—
	Oil	2.01 - 2.03 {0.079 - 0.080}	—
Piston ring thickness	1st	0.97 - 0.99 {0.038 - 0.039}	—
	2nd	0.97 - 0.99 {0.038 - 0.039}	—
Piston pin bore		20.002 - 20.008 {0.7875 - 0.7877}	20.030 {0.7886}
Piston pin O.D.		19.996 - 20.000 {0.7872 - 0.7874}	19.980 {0.7866}

**CONROD - CRANKSHAFT**

Unit: mm (in)

ITEM	STANDARD	LIMIT
Conrod small end I.D.	20.010 - 20.018 {0.7878 - 0.7881}	20.040 {0.7890}
Conrod big end side clearance	0.10 - 0.20 {0.004 - 0.008}	0.30 {0.01}
Conrod big end width	20.95 - 21.00 {0.825 - 0.827}	—
Crank pin width	21.10 - 21.15 {0.831 - 0.833}	—
Conrod big end oil clearance	0.032 - 0.056 {0.0013 - 0.0022}	0.080 {0.0031}
Crank pin O.D.	37.976 - 38.000 {1.4951 - 1.4961}	—
Crankshaft journal oil clearance	0.020 - 0.044 {0.0008 - 0.0017}	0.080 {0.0031}
Crankshaft journal O.D.	35.976 - 36.000 {1.4164 - 1.4173}	—
Crankshaft thrust clearance	0.05 - 0.13 {0.002 - 0.005}	—

Unit: mm (in)

ITEM	STANDARD		LIMIT
Crankshaft thrust bearing thickness	Left side	2.36 - 2.48 (0.093 - 0.098)	—
	Right side	2.42 - 2.44 (0.095 - 0.096)	—
Crankshaft runout	—		0.05 (0.002)

**OIL PUMP**

ITEM	STANDARD	LIMIT
Oil pump reduction ratio	1.819 (72/46 X 43/37)	—
Oil pressure (at 60°C, 140°F)	Above 300 kPa (3.0 kg/cm <sup>2</sup> , 43 psi) Below 600 kPa (6.0 kg/cm <sup>2</sup> , 85 psi) at 3 000 r/min.	—

**CLUTCH**

Unit: mm (in)

ITEM	STANDARD	LIMIT
Drive plate thickness	2.52 - 2.68 (0.100 - 0.106)	2.22 (0.087)
Driven plate distortion	—	0.10 (0.004)
Clutch spring free height	—	3.1 (0.12)
Clutch master cylinder bore	14.000 - 14.043 (0.5511 - 0.5529)	—
Clutch master cylinder piston diam.	13.957 - 13.984 (0.5495 - 0.5506)	—
Clutch release cylinder bore	35.700 - 35.762 (1.4055 - 1.4079)	—
Clutch release cylinder piston diam.	35.650 - 35.675 (1.4035 - 1.4045)	—



**TRANSMISSION + DRIVE CHAIN**

Unit: mm (in) Except ratio

ITEM		STANDARD	LIMIT
Primary reduction ratio		1.565 (72/46)	—
Final reduction ratio		3.200 (48/15)	—
Gear ratios	Low	2.384 (31/13)	—
	2nd	1.631 (31/19)	—
	3rd	1.250 (25/20)	—
	4th	1.045 (23/22)	—
	Top	0.913 (21/23)	—
Shift fork to groove clearance	No.1, No.2 & No.3	0.1 - 0.3 (0.004 - 0.012)	0.50 (0.020)
Shift fork groove width	No.1, No.2 & No.3	5.0 - 5.1 (0.197 - 0.201)	—
Shift fork thickness	No.1, No.2 & No.3	4.8 - 4.9 (0.189 - 0.193)	—
Drive chain	Type	TAKASAGO:RK532GSV	—
	Links	114 links	—
	20-pitch length	—	319.4 (12.6)
Drive chain slack		25 - 30 (1.0 - 1.2)	—
Gearshift lever height		65 (2.6)	—

## CARBURETOR

ITEM	SPECIFICATION					
	E-01, 16, 28	E-02,04, 17,21,25, 34,53	E-24	E-22	E-39	E-15
Carburetor type	MIKUNI BST36SS	←	←	←	←	←
Bore size	36 mm (1.4 in)	←	←	←	←	←
I.D.No.	40C00	40C40	40C50	40C60	40C80	40C90
Idle r/min.	1100 ± 100 r/min	←	←	←	←	←
Float height	14.6 ± 1.0 mm (0.57 ± 0.04 in)	←	←	←	←	←
Main jet (M.J.)	#122.5	←	←	←	←	←
Main air jet (M.A.J.)	1.5 mm	←	←	←	←	←
Jet needle (J.N.)	5E56-3rd	5E60-3rd	←	←	←	←
Needle jet (N.J.)	0-9	0-8	←	←	←	←
Pilot jet (P.J.)	#40	←	←	←	←	←
By-pass (B.P.)	0.8 mm	←	←	←	←	←
Pilot outlet (P.O.)	0.7 mm	←	←	←	←	←
Valve seat (V.S.)	2.3 mm	←	←	←	←	←
Starter jet (S.J.)	#45	←	←	←	←	←
Pilot screw (P.S.)	PRE-SET (2 turns out)	←	←	PRE-SET (1 5/8 turns out)	←	PRE-SET (2 turns out)
Pilot air jet (P.A.J.)	1.4 mm	←	←	←	←	←
Throttle cable play	0.5 - 1.0 mm (0.02 - 0.04 in)					

## CARBURETOR

ITEM	SPECIFICATION		
	E-03	E-33	E-18
Carburetor type	MIKUNI BST36SS	←	←
Bore size	36 mm (1.4 in)	←	←
I.D.No.	40C10	40C20	40C30
Idle r/min.	1200 ± 100 r/min	1100 ± 100 r/min	1100 ± $\frac{100}{\%}$ r/min
Float height	14.6 ± 1.0 mm (0.57 ± 0.04 in)	←	←
Main jet (M.J.)	# 122.5	←	# 110
Main air jet (M.A.J.)	1.5 mm	←	←
Jet needle (J.N.)	5D42	5D43	5D44-3rd
Needle jet (N.J.)	7-B	←	0-9
Pilot jet (P.J.)	# 37	←	# 30
By-pass (B.P.)	0.8 mm	←	←
Pilot outlet (P.O.)	0.7 mm	←	←
Valve seat (V.S.)	2.3 mm	←	←
Starter jet (G.S.)	# 45	←	# 42.5
Pilot screw (P.S.)	PRE-SET	←	PRE-SET (1 1/2 turns out)
Pilot air jet (P.A.J.)	1.35 mm	1.2 mm	1.35 mm
Throttle cable play	0.5 - 1.0 mm (0.02 - 0.04 in)	←	←

## ELECTRICAL

Unit: mm (in)

ITEM	SPECIFICATION		NOTE
Ignition timing	13° B.T.D.C. at 1500 r/min		California model only
	7° B.T.D.C. at 1500 r/min		
Firing order	1-2-4-3		
Spark plug	Type	NGK: JR9B	JR10B (OPT. Cold type)
	Gap	0.6 - 0.7 (0.024 - 0.028)	
Spark performance	Over 8 (0.3) at 1 atm.		
Signal coil resistance	Approx. 135 - 200Ω		Tester range: (× 100Ω)
Ignition coil resistance	Primary	⊕ tap - ⊖ tap Approx. 2.4 - 3.2Ω	Tester range: (× 1Ω)
	Secondary	Plug cap - Plug cap Approx. 30 - 40 kΩ	Tester range: (× 1kΩ)

Unit: mm (in)

ITEM		SPECIFICATION		NOTE
Generator		Slip ring O.D.	Limit: 14.0 (0.55)	N.D.
		Brush length	Limit: 4.5 (0.18)	
Regulated voltage		Above 13.5V at 5 000 r/min.		
Starter motor		Brush length	Limit: 6 (0.2)	MITSUBA
		Commutator under-cut	Limit: 0.2 (0.008)	
Starter relay resistance		3 - 5 $\Omega$		
Battery	Type designation	YB14L-A2		
	Capacity	12V 50.4 kC (14Ah)/10HR		
	Standard electrolyte S.G.	1.28 at 20°C (68°F)		
Fuse size	Headlight	10A		
	Turn signal	10A		
	Ignition	10A		
	Taillight	10A		
	Power source	10A		
Circuit breaker		30A		

## WATTAGE

Unit: W

ITEM		SPECIFICATION					
		E-01, 02, 16, 21, 24	E-03, 28, 33	E-04, 17, 22, 25, 39, 53	E-15	E-18	E-34
Headlight	HI	60 × 2 pcs.	←	60 + 55	60 × 2 pcs.	60	35 × 2 pcs.
	LO	55 × 2 pcs.	←	55	←	←	35 × 2 pcs.
Parking or position light		4 × 2 pcs.	←	4	←	←	3 × 2 pcs.
Tail/Brake light		5/21	←	←	←	←	←
Turn signal light		21	←	←	←	←	←
Tachometer light		3	←	←	←	←	←
Speedometer light		3	←	←	←	←	←
Fuel level indicator light		3	←	←	←	←	←
Turn signal indicator light		3	←	←	←	←	←
High beam indicator light		1.7	←	←	←	←	←
Neutral indicator light		3	←	←	←	←	←
Oil pressure indicator light		1.7	←	←	←	←	←
License light		5	←	←	←	←	←

**BRAKE + WHEEL**

Unit: mm (in)

ITEM		STANDARD		LIMIT
Rear brake pedal height		65 (2.6)		—
Brake disc thickness	Front	5.0 ± 0.2 (0.197 ± 0.008)		4.5 (0.18)
	Rear	6.0 ± 0.2 (0.236 ± 0.008)		5.5 (0.22)
Brake disc runout		—		0.30 (0.012)
Master cylinder bore	Front	14.000 - 14.043 (0.5511 - 0.5529)		—
	Rear	12.700 - 12.743 (0.5000 - 0.5017)		—
Master cylinder piston diam.	Front	13.957 - 13.984 (0.5495 - 0.5506)		—
	Rear	12.657 - 12.684 (0.4983 - 0.4994)		—
Brake caliper cylinder bore	Trailing	Front	33.960 - 34.010 (1.3370 - 1.3390)	—
			30.230 - 30.280 (1.1902 - 1.1921)	—
	Rear	38.180 - 38.256 (1.5031 - 1.5061)	—	
Brake caliper piston diam.	Trailing	Front	33.878 - 33.928 (1.3338 - 1.3357)	—
			30.130 - 30.180 (1.1862 - 1.1882)	—
	Rear	38.098 - 38.148 (1.5000 - 1.5019)	—	
Wheel rim runout	Axial	—		2.0 (0.08)
	Radial	—		2.0 (0.08)
Wheel axle runout	Front	—		0.25 (0.010)
	Rear	—		0.25 (0.010)
Tire size	Front	120/70 ZR17		—
	Rear	160/60 ZR17		—
Tire tread depth	Front	—		1.6 (0.06)
	Rear	—		2.0 (0.08)

**SUSPENSION**

Unit: mm (in)

ITEM	STANDARD	LIMIT	NOTE
Front fork stroke	120 (4.72)	—	
Front fork spring free length	—	347 (13.7)	
Front fork oil level	113 (4.45)	—	For U.S.A. model
	146 (5.75)	—	For the other models
Rear wheel travel	140 (5.51)	—	
Swingarm pivot shaft runout	—	0.3 (0.01)	

**TIRE PRESSURE**

COLD INFLATION TIRE PRESSURE	SOLO RIDING			DUAL RIDING		
	kPa	kg/cm <sup>2</sup>	psi	kPa	kg/cm <sup>2</sup>	psi
FRONT	230	2.30	33	250	2.50	36
REAR	250	2.50	36	290	2.90	42

## FUEL + OIL

ITEM	SPECIFICATION		NOTE	
Fuel type	<ul style="list-style-type: none"> <li>Use only unleaded gasoline of at least 87 pump octane (<math>\frac{R+M}{2}</math>) or 91 octane or higher rated by the research method.</li> <li>Gasoline containing MTBE (Methyl Tertiary Butyl Ether), less than 10% ethanol, or less than 5% methanol with appropriate cosolvents and corrosion inhibitor is permissible.</li> </ul>		For U.S.A. model	
	Use only unleaded gasoline of at least 87 pump octane ( $\frac{R+M}{2}$ ) or 91 octane or higher rated by the research method.		For canada model	
	Gasoline used should be graded 85-95 octane or higher. An unleaded gasoline is recommended.		For the other models	
Fuel tank including reserve	18.5 L (4.8/4.1 US/Imp gal)		For california model	
	20.5 L (5.4/4.5 US/Imp gal)		For switzerland model	
	21.0 L (5.5/4.6 US/Imp gal)		For the other models	
	reserve	4.5 L (4.8/4.0 US/Imp qt)		For switzerland and california models
		5.0 L (5.3/4.4 US/Imp qt)		For the other models
Engine oil type	SAE 10W/40, API SE or SF			
Engine oil capacity	Change	4 000 ml (4.2/3.5 US/Imp qt)		
	Filter change	4 200 ml (4.4/3.7 US/Imp qt)		
	Overhaul	5 100 ml (5.4/4.5 US/Imp qt)		
Front fork oil type	Fork oil #5			
Front fork oil capacity (each leg)	453 ml (15.3/16.0 US/Imp oz)		For U.S.A. model	
	418 ml (14.1/14.7 US/Imp oz)		For the other models	
Brake fluid type	DOT4			

# **EMISSION CONTROL INFORMATION**

## **CONTENTS**

<b>EMISSION CONTROL CARBURETOR COMPONENTS .....</b>	<b>8- 1</b>
<b>EVAPORATIVE EMISSION CONTROL SYSTEM .....</b>	<b>8- 2</b>
<b>CANISTER HOSE ROUTING.....</b>	<b>8- 3</b>
<b>AIR SUCTION SYSTEM.....</b>	<b>8- 4</b>
<b>AIR SUCTION HOSE ROUTING.....</b>	<b>8- 5</b>



## EMISSION CONTROL CARBURETOR COMPONENTS

GSX-R1100 motorcycles are equipped with precision, manufactured carburetors for emission level control. These carburetors require special mixture control components and other precision adjustments to function properly.

There are several carburetor mixture control components in each carburetor assembly. Three (3) of these components are machined to much closer tolerances than standard machined carburetor jets. These three (3) particular jets — MAIN JET, NEEDLE JET, PILOT JET — must not be replaced by standard jets. To aid in identifying these three (3) jets a different design of letter and number are used. If replacement of these close tolerance jets becomes necessary, be sure to replace them with the same type close tolerance jets marked as in the examples shown below.

The jet needle is also of special manufacture. Only one clip position is provided on the jet needle. If replacement becomes necessary the jet needle may only be replaced with an equivalent performing replacement component. Suzuki recommends that Genuine Suzuki Parts be utilized whenever possible for the best possible performance and durability.

Conventional Figures Used on Standard Tolerance Jet Components	1	2	3	4	5	6	7	8	9	0
Emission Type Figures Used On Close Tolerance jet Components	1	2	3	4	5	6	7	8	9	0

The carburetor specification for the emission-controlled GSX-R1100 are as follows.

Carburetor I.D. No.	Main Jet	Needle Jet	Jet Needle	Pilot Jet	Pilot Screw
40C20 (California model)	# 1225	7-R	5D43	# 30	PRE-SET DO NOT ADJUST
40C10 (Other state models)			5D42		

The pilot screw is pre-set by the factory utilizing specialized testing and adjusting procedures. The pilot screw is not adjustable as the idle circuit is "sealed" after factory adjustment. Adjusting, interfering with, improper replacement, or resetting of any of the carburetor components may adversely affect carburetor performance and cause the motorcycle to exceed the exhaust emission level limits. If persons, who are unaware of these special carburetor servicing requirements tamper with the carburetors the Suzuki dealer should restore the carburetors to their original condition or if unable to effect repairs, contact the distributors representative for further technical information and assistance.

# EVAPORATIVE EMISSION CONTROL SYSTEM (Only for California model)

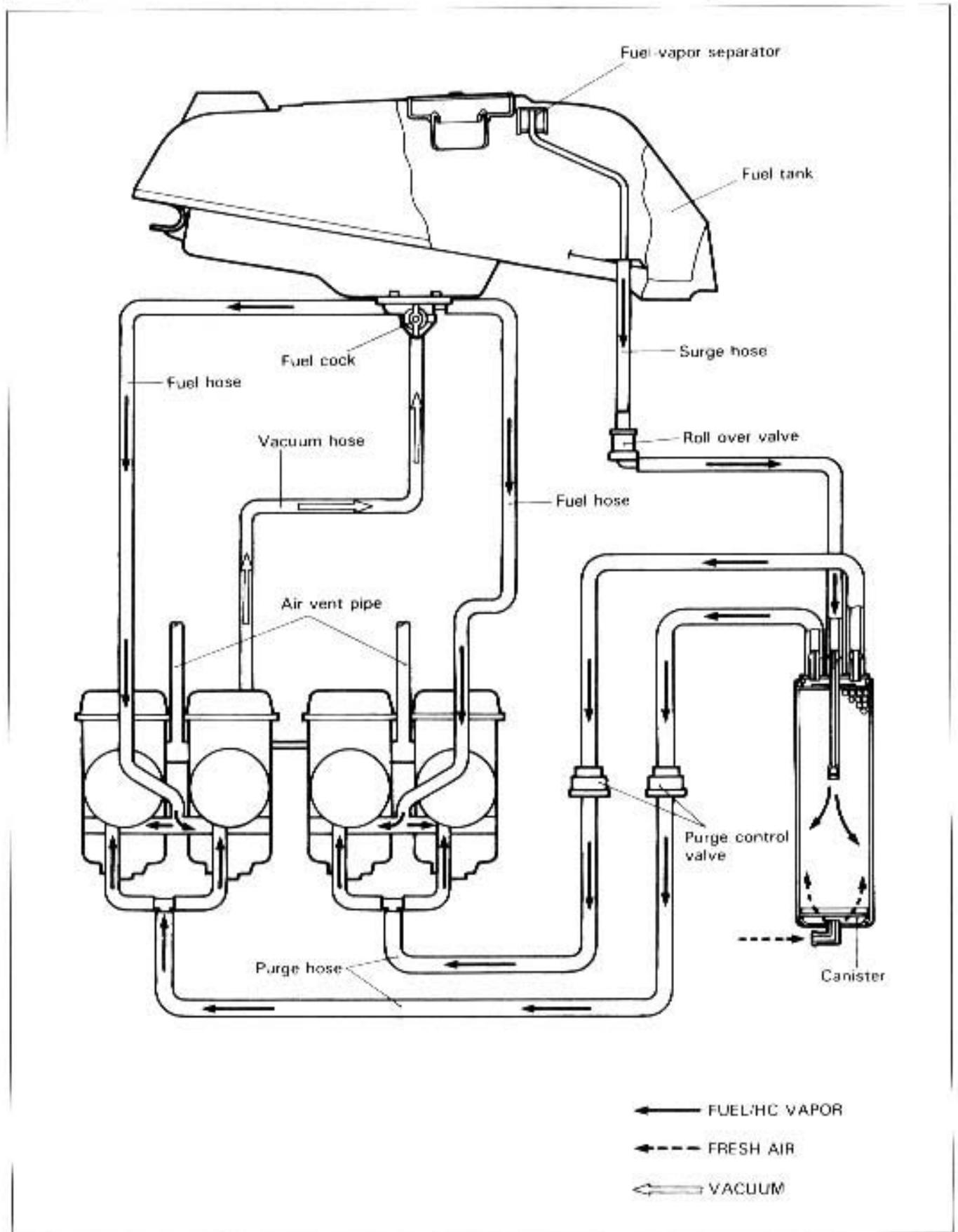

# CANISTER HOSE ROUTING (Only for California model)

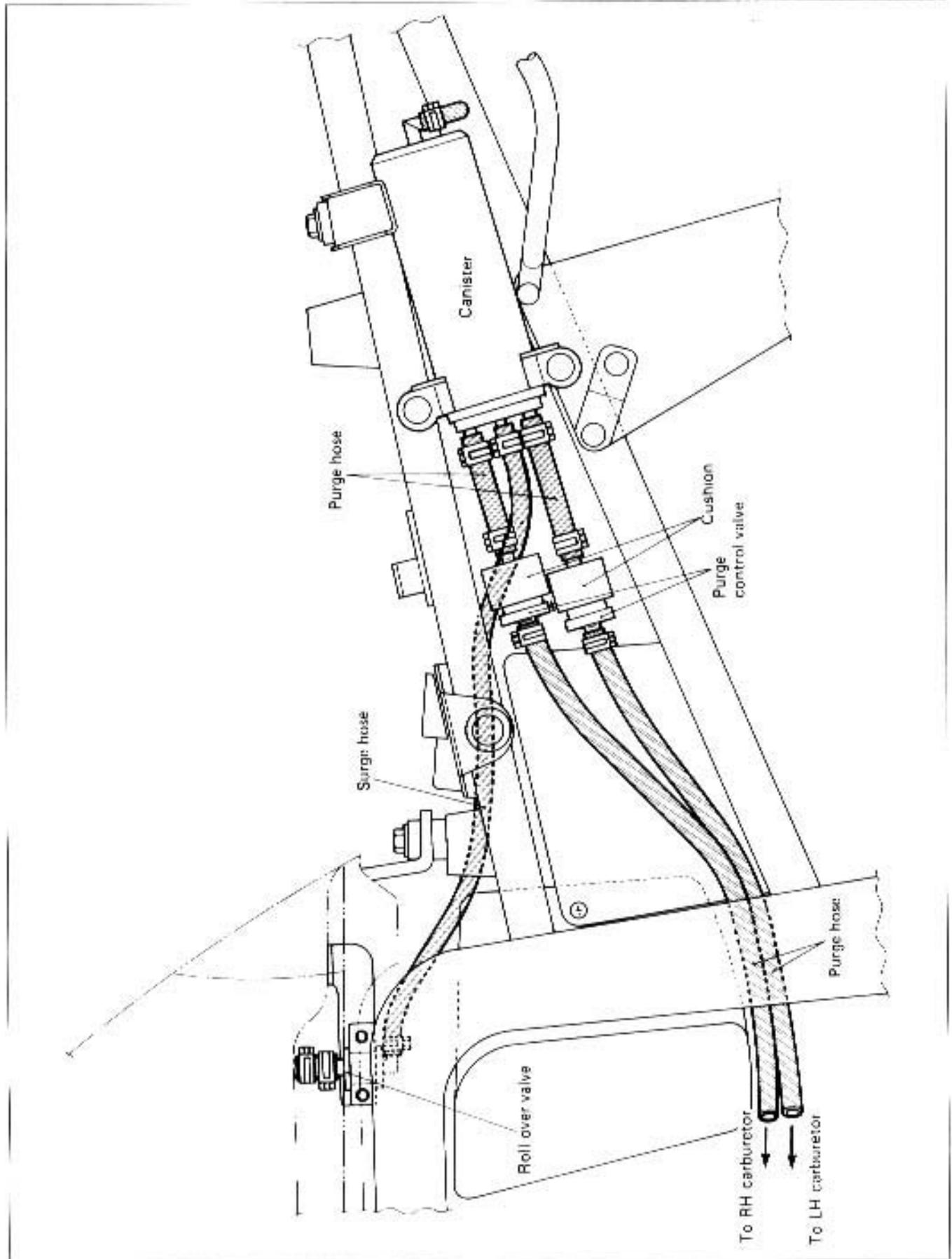

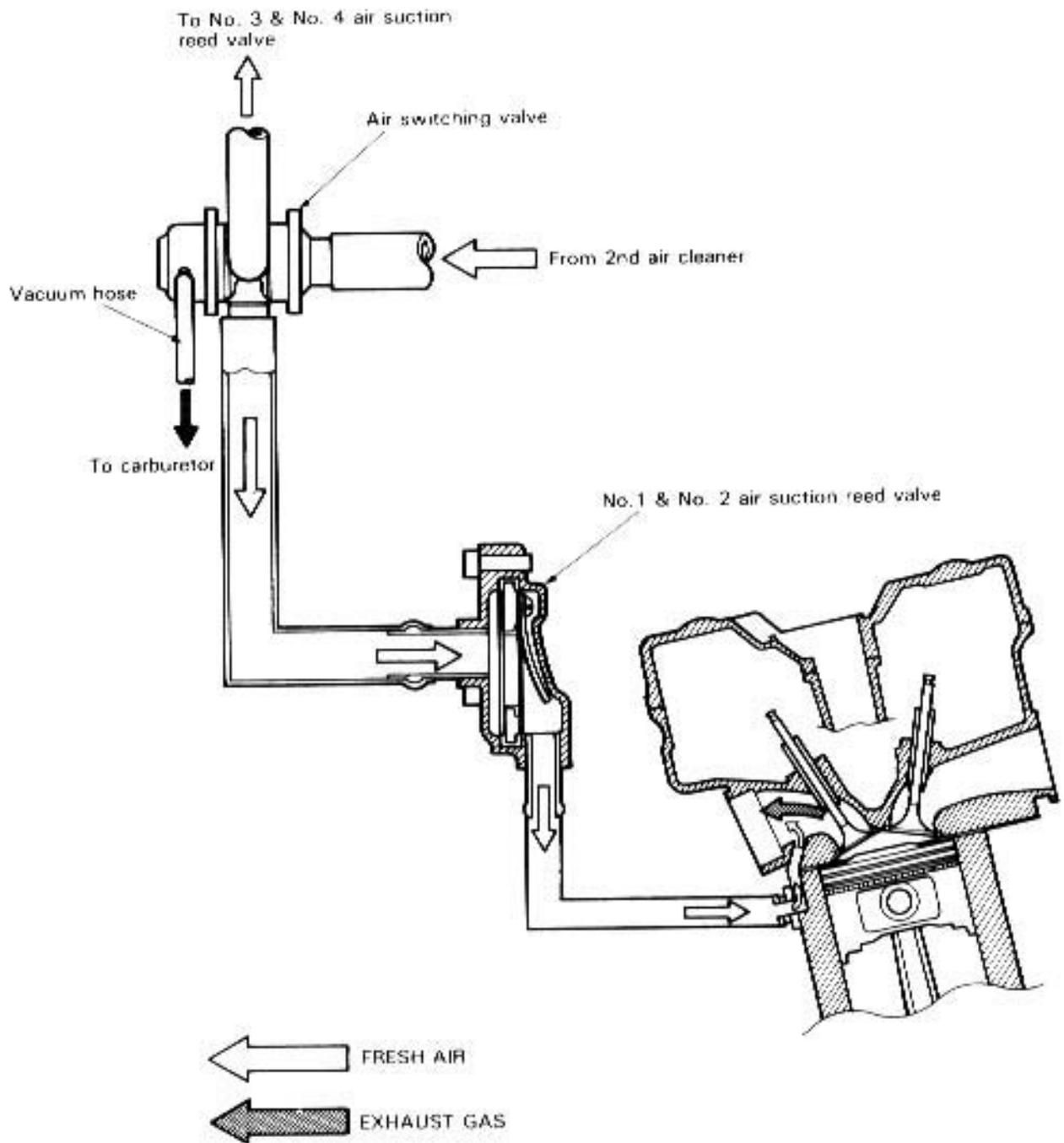
**AIR SUCTION SYSTEM (Only for California model)**

# AIR SUCTION HOSE ROUTING (Only for California model)

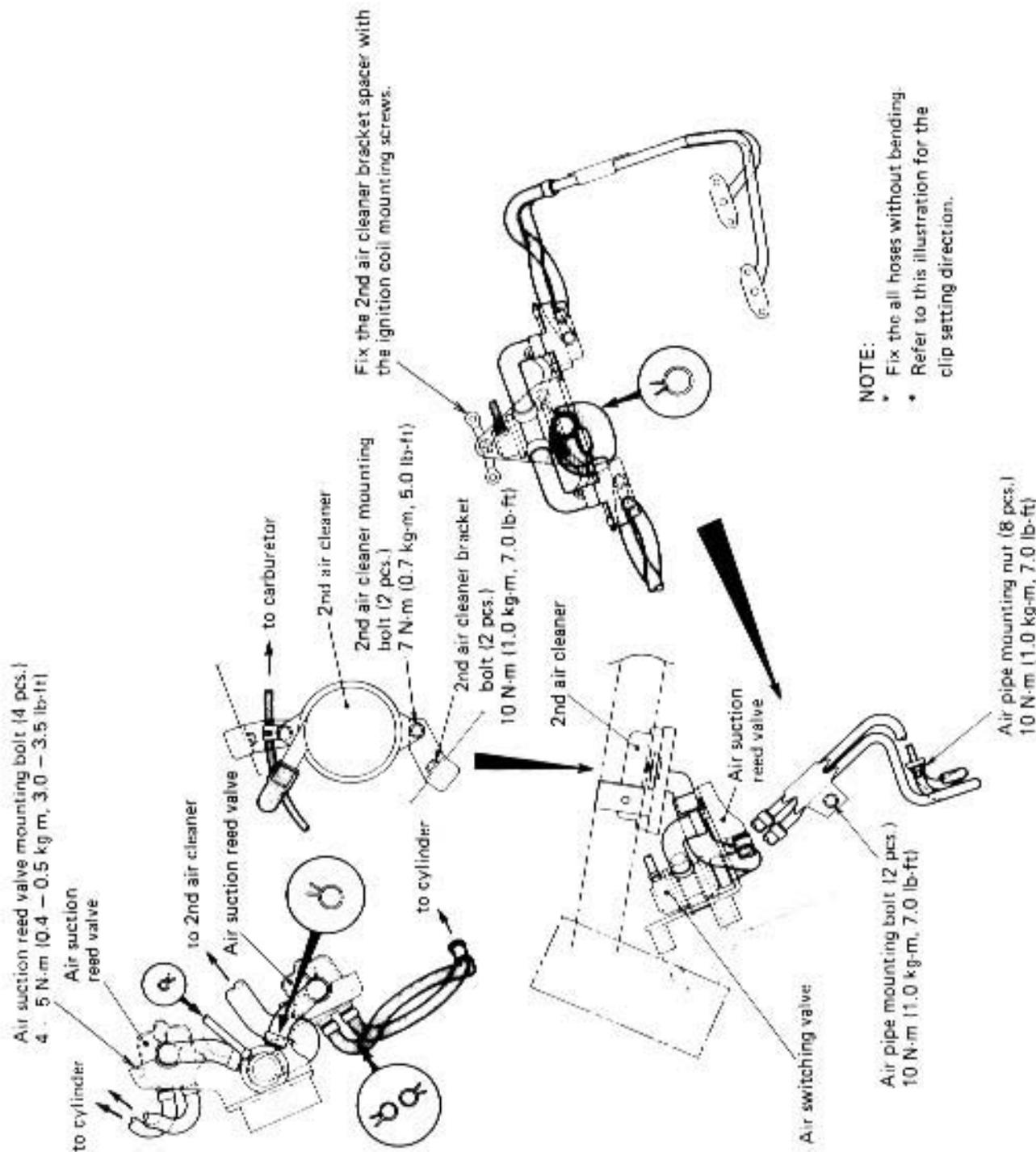

# GSX-R1100L ('90-MODEL)

*This section describes service data, service specifications and servicing procedures which differ from those of the GSX-R1100K ('89-model).*

**NOTE:**

*Any differences between "K" ('89-model) and "L" ('90-model) in specifications and service data are clearly indicated with the asterisk marks (\*). Please refer to the sections 1 through 8 for details which are not given in this section.*

## CONTENTS

<b>SPECIFICATIONS</b> .....	<b>9- 1</b>
<b>SERVICE DATA</b> .....	<b>9- 3</b>
<b>TIGHTENING TORQUE</b> .....	<b>9-14</b>
<b>ENGINE MOUNTING</b> .....	<b>9-15</b>
<b>CYLINDER HEAD</b> .....	<b>9-16</b>
<b>STEERING</b> .....	<b>9-17</b>
<b>SWINGARM</b> .....	<b>9-18</b>
<b>SHOCK ABSORBER AND CUSHION LEVER</b> .....	<b>9-20</b>
<b>SUSPENSION SETTING</b> .....	<b>9-21</b>
<b>WIRING DIAGRAM</b> .....	<b>9-22</b>
<b>HOSE ROUTING</b> .....	<b>9-23</b>
<b>THROTTLE CABLE ROUTING</b> .....	<b>9-26</b>

## SPECIFICATIONS

### DIMENSIONS AND DRY MASS

Overall length.....	*2080 mm (81.9 in)
Overall width.....	755 mm (29.7 in)
Overall height.....	1150 mm (45.3 in)
Wheelbase.....	*1465 mm (57.7 in)
Ground clearance.....	110 mm (4.3 in)
Dry mass.....	*215 kg (474 lbs)..... For E-03 model
	*217 kg (478 lbs)..... For E-33 model

### ENGINE

Type.....	Four-stroke, Air-cooled with SACS, DOHC, TSCC
Number of cylinders.....	4
Bore.....	78.0 mm (3.07 in)
Stroke.....	59.0 mm (2.32 in)
Piston displacement.....	1127cm <sup>3</sup> (68.8 cu.in)
Carburetor.....	MIKUNI BST36SS, four
Air cleaner.....	Polyester fiber element
Starter system.....	Electric starter
Lubrication system.....	Wet sump

### TRANSMISSION

Clutch.....	Wet multi-plate type, hydraulically operated
Transmission.....	5-speed constant mesh
Gearshift pattern.....	1-down, 4-up
Primary reduction.....	1.565 (72/46)
Final reduction.....	3.200 (48/15)
Gear ratios, Low.....	2.384 (31/13)
2nd.....	1.631 (31/19)
3rd.....	1.250 (25/20)
4th.....	1.045 (23/22)
Top.....	0.913 (21/23)
Drive chain.....	*TAKASAGO RK532GSV2, 118 links

## CHASSIS

Front suspension.....	Telescopic, coil spring, oil damped, inner rod type, spring pre-load fully adjustable, damping force compression 10-way and rebound 8-way adjustable.
Rear suspension.....	*Full-floating suspension system, gas/oil damped, coil spring, spring pre-load 7-way adjustable, damping force compression 19-way and rebound 19-way adjustable
Steering angle.....	30° (right & left)
Caster.....	65° 10'
Trail.....	99 mm (3.9in)
Turning radius.....	3.2 m (10.5ft)
Front brake.....	Disc brake, twin
Rear brake.....	Disc brake
Front tire size.....	* 130/60ZR17
Rear tire size.....	* 180/55ZR17
Front fork stroke.....	120mm (4.7in)
Rear wheel travel.....	* 158mm (6.2in)

## ELECTRICAL

Ignition type.....	Fully Transistorized
Ignition timing.....	7° B.T.D.C. at 1500 r/min..... For E-33 model 13° B.T.D.C. at 1500 r/min..... For E-03 model
Spark plug.....	N.G.K.: JR9B
Battery.....	12V 50.4 kC (14Ah)/10HR
Generator.....	Three-phase A.C. Generator
Fuse.....	*20/10/10/10/10A
Circuit breaker.....	30A

## CAPACITIES

Fuel tank, Including reserve.....	18.5 L (4.8/4.1 US/Imp gal)..... For E-33 model 21.0 L (5.5/4.6 US/Imp gal)..... For E-03 model
Engine oil, Oil change with oil filter change.....	4.2 L (4.4/3.7 US/Imp qt)
Front fork oil.....	*415 ml (14.0/14.6 US/Imp oz)

These specifications are subject to change without notice.  
Asterisk mark(\*) indicates the new L-model specifications.

( E-33: California (U.S.A.) model )  
( E-03: U.S.A. model )



## SERVICE DATA

### VALVE + GUIDE

Unit: mm (in)

ITEM	STANDARD		LIMIT
Valve diam.	IN.	28.5 (1.12)	—
	EX.	25 (1.0)	—
Valve lift	IN.	8.8 (0.35)	—
	EX.	8.2 (0.32)	—
Valve clearance (when cold)	IN.	0.10 - 0.15 (0.004 - 0.006)	—
	EX.	0.18 - 0.23 (0.007 - 0.009)	—
Valve guide to valve stem clearance	IN.	0.020 - 0.047 (0.0008 - 0.0019)	0.35 (0.014)
	EX.	0.040 - 0.067 (0.0016 - 0.0026)	0.35 (0.014)
Valve guide I.D.	IN. & EX.	5.000 - 5.012 (0.1969 - 0.1973)	—
Valve stem O.D.	IN.	4.965 - 4.980 (0.1955 - 0.1961)	—
	EX.	4.945 - 4.960 (0.1947 - 0.1953)	—
Valve stem runout	IN. & EX.	—	0.05 (0.002)
Valve head thickness	IN. & EX.	—	0.5 (0.02)
Valve stem end length	IN. & EX.	—	2.5 (0.10)
Valve seat width	IN. & EX.	0.9 - 1.1 (0.035 - 0.043)	—
Valve head radial runout	IN. & EX.	—	0.03 (0.001)
Valve spring free length (IN. & EX.)	INNER	—	35.0 (1.38)
	OUTER	—	37.8 (1.49)
Valve spring tension (IN. & EX.)	INNER	5.3 - 6.5 kg (11.7 - 14.3 lbs) at length 28 mm (1.1 in)	—
	OUTER	13.1 - 15.1 kg (28.9 - 33.3 lbs) at length 31.5 mm (1.2 in)	—

**CAMSHAFT + CYLINDER HEAD**

Unit: mm (in)

ITEM	STANDARD		LIMIT
	IN.		
Cam height	IN.	33.878 - 33.918 (1.3338 - 1.3354)	33.580 (1.3220)
	EX.	33.533 - 33.573 (1.3202 - 1.3218)	33.240 (1.3087)
Camshaft journal oil clearance	IN. & EX.	0.032 - 0.066 (0.0013 - 0.0026)	0.150 (0.0059)
Camshaft journal holder I.D.	IN. & EX.	22.012 - 22.025 (0.8666 - 0.8671)	—
Camshaft journal O.D.	IN. & EX.	21.959 - 21.980 (0.8645 - 0.8654)	—
Camshaft runout	IN. & EX.	—	0.10 (0.004)
Cam chain 20-pitch length		—	158.0 (6.22)
Cam chain pin (at arrow "3")		22nd pin	—
Rocker arm I.D.	IN. & EX.	12.000 - 12.018 (0.4724 - 0.4731)	—
Rocker arm shaft O.D.	IN. & EX.	11.973 - 11.984 (0.4714 - 0.4718)	—
Cylinder head distortion		—	0.20 (0.008)

**CYLINDER + PISTON - PISTON RING**

Unit: mm (in)

ITEM	STANDARD		LIMIT
	1st	N	
Compression pressure	1 200 - 1 400 kPa 12 - 14 kg/cm <sup>2</sup> 170 - 199 psi		1 000 kPa 10 kg/cm <sup>2</sup> 142 psi
Compression pressure difference	—		200 kPa 2 kg/cm <sup>2</sup> 28 psi
Piston to cylinder clearance	0.050 - 0.060 (0.0020 - 0.0024)		0.120 (0.0047)
Cylinder bore	78.000 - 78.015 (3.0709 - 3.0715)		78.080 (3.0740)
Piston diam.	77.945 - 77.960 (3.0687 - 3.0693) Measure at 15 mm (0.6 in) from the skirt end.		77.880 (3.0661)
Cylinder distortion	—		0.20 (0.008)
Piston ring free end gap	1st	N	Approx. 10 (0.39)
	2nd	N	Approx. 11.5 (0.45)

Unit: mm (in)

ITEM	STANDARD		LIMIT
Piston ring end gap	1st	0.20 - 0.35 (0.008 - 0.014)	0.7 (0.03)
	2nd	0.35 - 0.50 (0.014 - 0.020)	1.0 (0.04)
Piston ring to groove clearance	1st	—	0.180 (0.007)
	2nd	—	0.150 (0.006)
Piston ring groove width	1st	1.01 - 1.03 (0.040 - 0.041)	—
	2nd	1.01 - 1.03 (0.040 - 0.041)	—
	Oil	2.01 - 2.03 (0.079 - 0.080)	—
Piston ring thickness	1st	0.97 - 0.99 (0.038 - 0.039)	—
	2nd	0.97 - 0.99 (0.038 - 0.039)	—
Piston pin bore	20.002 - 20.008 (0.7875 - 0.7877)		20.030 (0.7886)
Piston pin O.D.	19.996 - 20.000 (0.7872 - 0.7874)		19.980 (0.7866)

**CONROD + CRANKSHAFT**

Unit: mm (in)

ITEM	STANDARD		LIMIT
Conrod small end I.D.	20.010 - 20.018 (0.7878 - 0.7881)		20.040 (0.7890)
Conrod big end side clearance	0.10 - 0.20 (0.004 - 0.008)		0.30 (0.01)
Conrod big end width	20.95 - 21.00 (0.825 - 0.827)		—
Crank pin width	21.10 - 21.15 (0.831 - 0.833)		—
Conrod big end oil clearance	0.032 - 0.056 (0.0013 - 0.0022)		0.080 (0.0031)
Crank pin O.D.	37.976 - 38.000 (1.4951 - 1.4961)		—
Crankshaft journal oil clearance	0.020 - 0.044 (0.0008 - 0.0017)		0.080 (0.0031)
Crankshaft journal O.D.	35.976 - 36.000 (1.4164 - 1.4173)		—
Crankshaft thrust clearance	0.05 - 0.13 (0.002 - 0.005)		—

Unit: mm (in)

ITEM	STANDARD		LIMIT
Crankshaft thrust bearing thickness	Left side	2.36 - 2.48 (0.093 - 0.098)	—
	Right side	2.42 - 2.44 (0.095 - 0.096)	—
Crankshaft runout	—		0.05 (0.002)

**OIL PUMP**

ITEM	STANDARD	LIMIT
Oil pump reduction ratio	1.819 (72/46 × 43/37)	—
Oil pressure (at 60°C, 140°F)	Above 300 kPa (3.0 kg/cm <sup>2</sup> , 43 psi) Below 600 kPa (6.0 kg/cm <sup>2</sup> , 85 psi) at 3 000 r/min.	—

**CLUTCH**

Unit: mm (in)

ITEM	STANDARD	LIMIT
Drive plate thickness	2.52 - 2.68 (0.100 - 0.106)	2.22 (0.087)
Driven plate distortion	—	0.10 (0.004)
Clutch spring free height	—	3.1 (0.12)
Clutch master cylinder bore	14.000 - 14.043 (0.5511 - 0.5529)	—
Clutch master cylinder piston diam.	13.957 - 13.984 (0.5495 - 0.5506)	—
Clutch release cylinder bore	35.700 - 35.762 (1.4055 - 1.4079)	—
Clutch release cylinder piston diam.	35.650 - 35.675 (1.4035 - 1.4045)	—

**TRANSMISSION – DRIVE CHAIN**

Unit: mm (in) Except ratio

ITEM		STANDARD	LIMIT
Primary reduction ratio		1.565 (72/46)	—
Final reduction ratio		3.200 (48/15)	—
Gear ratios	Low	2.384 (31/13)	—
	2nd	1.631 (31/19)	—
	3rd	1.250 (25/20)	—
	4th	1.045 (23/22)	—
	Top	0.913 (21/23)	—
Shift fork to groove clearance	No. 1, No. 2 & No. 3	0.1 – 0.3 (0.004 – 0.012)	0.50 (0.020)
Shift fork groove width	No. 1, No. 2 & No. 3	5.0 – 5.1 (0.197 – 0.201)	—
Shift fork thickness	No. 1, No. 2 & No. 3	4.8 – 4.9 (0.189 – 0.193)	—
Drive chain	Type	*TAKASAGO:RK532GSV2	—
	Links	*118 links	—
	20 – pitch length	—	319.4 (12.6)
Drive chain slack		25 – 30 (1.0 – 1.2)	—
Gearshift lever height		65 (2.6)	—

Asterisk mark (\*) indicates the new L-model specifications.

## CARBURETOR

ITEM	SPECIFICATION					
	E-01, 16, 28	E-02,04, 17,21,25, 34,53	E-24	E-22	E-39	E-15
Carburetor type	MIKUNI BST36SS	←	←	←	*	←
Bore size	36 mm (1.4 in)	←	←	←	←	←
I.D.No.	40C00	40C40	40C50	40C60	40C80	40C90
Idle r/min.	1100 + 100 r/min	←	←	*	←	←
Float height	14.6 + 1.0 mm (0.57 ± 0.04 in)	←	←	*	←	←
Main jet (M.J.)	№122.5	←	←	←	←	←
Main air jet (M.A.J.)	1.5 mm	←	←	←	←	←
Jet needle (J.N.)	5E56-3rd	5E60-3rd	←	←	←	*
Needle jet (N.J.)	0 - 9	0 - 8	←	←	←	←
Pilot jet (P.J.)	№40	*	←	←	←	←
By-pass (B.P.)	0.8 mm	←	←	←	←	←
Pilot outlet (P.O.)	0.7 mm	←	←	←	←	←
Valve seat (V.S.)	2.3 mm	←	←	←	←	←
Starter jet (G.S.)	№45	←	←	←	*	←
Pilot screw (P.S.)	PRE-SET (2 turns out)	←	←	PRE-SET (1 5/8 turns out)	←	PRE-SET (2 turns out)
Pilot air jet (P.A.J.)	1.4 mm	←	←	←	←	*
Throttle cable play	0.5 - 1.0 mm (0.02 - 0.04 in)					

## CARBURETOR

ITEM	SPECIFICATION		
	E-03	E-33	E-18
Carburetor type	MIKUNI BST36SS	←	←
Bore size	36 mm (1.4 in)	←	←
I.D.No.	40C10	40C20	40C30
Idle r/min.	1200 ± 100 r/min	1100 + 100 r/min	1100 - $\frac{100}{60}$ r/min
Float height	14.6 + 1.0 mm (0.57 ± 0.04 in)	←	←
Main jet (M.J.)		←	#110
Main air jet (M.A.J.)	1.5 mm	←	←
Jet needle (J.N.)	5D42	5D43	5D44-3rd
Needle jet (N.J.)		←	0-9
Pilot jet (P.J.)		←	#30
By-pass (B.P.)	0.8 mm	←	←
Pilot outlet (P.O.)	0.7 mm	←	←
Valve seat (V.S.)	2.3 mm	←	←
Starter jet (S.J.)	#45	←	#42.5
Pilot screw (P.S.)	PRE-SET	←	PRE-SET (1 1/2 turns out)
Pilot air jet (P.A.J.)	1.35 mm	1.2 mm	1.35 mm
Throttle cable play	0.5 - 1.0 mm (0.02 - 0.04 in)	←	←

## ELECTRICAL

Unit: mm (in)

ITEM	SPECIFICATION	NOTE
Ignition timing	13° B.T.D.C. at 1500 r/min	
	7° B.T.D.C. at 1500 r/min	California model only
Firing order	1.2.4.3	
Spark plug	Type NGK: JR9B	JR10B {OPT. Cold type}
	Gap 0.6 - 0.7 (0.024 - 0.028)	
Spark performance	Over 8 (0.3) at 1 atm.	
Signal coil resistance	Approx. 135 - 200Ω	Tester range: {× 100Ω}
Ignition coil resistance	Primary ⊕ tap - ○ tap Approx. 2.4 - 3.2Ω	Tester range: {× 1Ω}
	Secondary Plug cap - Plug cap Approx. 30 - 40 kΩ	Tester range: {× 1kΩ}

Unit: mm (in)

ITEM		SPECIFICATION		NOTE
Generator	Slip ring O.D.	Limit: 14.0 (0.55)		N.D.
	Brush length	Limit: 4.5 (0.18)		
Regulated voltage		Above 13.5V at 5 000 r/min.		
Starter motor	Brush length	Limit: 6 (0.2)		MITSUBA
	Commutator under-cut	Limit: 0.2 (0.008)		
Starter relay resistance		3 - 5 $\Omega$		
Battery	Type designation	YB14L-A2		
	Capacity	12V 50.4 kC (14Ah)/10HR		
	Standard electrolyte S.G.	1.28 at 20°C (68°F)		
Fuse size	Headlight	*20A		
	Turn signal	10A		
	Ignition	10A		
	Taillight	10A		
	Power source	10A		
Circuit breaker		30A		

**WATTAGE**

Unit: W

ITEM		SPECIFICATION				
		E-01, 02, 16, 18, 21, 24	E-03, 28, 33	E-04, 17 22, 25, 39, 53	E-15	E-34
Headlight	HI	60 × 2pcs.	←	60 + 55	60 × 2pcs.	35 × 2pcs.
	LO	55 × 2pcs.	←	55	←	35 × 2pcs.
Parking or position light		4 × 2pcs.	←	4	←	3 × 2pcs.
Tail/Brake light		5/21	←	←	←	*
Turn signal light		21	←	←	←	←
Tachometer light		3	←	←	←	←
Speedometer light		3	←	←	←	←
Fuel level indicator light		3	←	←	←	←
Turn signal indicator light		3	←	←	←	←
High beam indicator light		1.7	←	←	←	←
Neutral indicator light		3	←	←	←	←
Oil pressure indicator light		1.7	←	←	←	←
License light		5	←	←	←	←

Asterisk mark (\*) indicates the new L-model specifications.



Unit: mm (in)

**BRAKE + WHEEL**

ITEM		STANDARD	LIMIT
Rear brake pedal height		65 (2.6)	—
Brake disc thickness	Front	5.0 + 0.2 (0.197 ± 0.008)	4.5 (0.18)
	Rear	6.0 + 0.2 (0.236 ± 0.008)	5.5 (0.22)
Brake disc runout		—	0.30 (0.012)
Master cylinder bore	Front	14.000 - 14.043 (0.5511 - 0.5529)	—
	Rear	12.700 - 12.743 (0.5000 - 0.5017)	—
Master cylinder piston diam.	Front	13.957 - 13.984 (0.5495 - 0.5506)	—
	Rear	12.657 - 12.684 (0.4983 - 0.4994)	—
Brake caliper cylinder bore	Trailing	Front	33.960 - 34.010 (1.3370 - 1.3390)
			30.230 - 30.280 (1.1902 - 1.1921)
	Leading	Rear	38.180 - 38.256 (1.5031 - 1.5061)
Brake caliper piston diam.	Trailing	Front	33.878 - 33.928 (1.3338 - 1.3357)
			30.130 - 30.180 (1.1862 - 1.1882)
	Leading	Rear	38.098 - 38.148 (1.5000 - 1.5019)
Wheel rim runout	Axial	—	2.0 (0.08)
	Radial	—	2.0 (0.08)
Wheel axle runout	Front	—	0.25 (0.010)
	Rear	—	0.25 (0.010)
Tire size	Front	*130/60 ZR17	—
	Rear	*180/55 ZR17	—
Tire tread depth	Front	—	1.6 (0.06)
	Rear	—	2.0 (0.08)

Asterisk mark (\*) indicates the new L-model specifications.

**SUSPENSION**

Unit: mm (in)

ITEM	STANDARD	LIMIT	NOTE
Front fork stroke	120 (4.72)	—	
Front fork spring free length	—	347 (13.7)	
Front fork oil level	* 145 (5.71)	—	
Rear wheel travel	* 158 (6.2)	—	
Swingarm pivot shaft runout	—	0.3 (0.01)	

**\*TIRE PRESSURE**

COLD INFLATION TIRE PRESSURE	SOLO RIDING			DUAL RIDING		
	kPa	kg/cm <sup>2</sup>	psi	kPa	kg/cm <sup>2</sup>	psi
FRONT	220	2.20	32	220	2.20	32
REAR	250	2.50	36	290	2.90	42

Asterisk mark (\*) indicates the new L-model specifications.

## FUEL + OIL

ITEM	SPECIFICATION	NOTE
Fuel type	<ul style="list-style-type: none"> <li>Use only unleaded gasoline of at least 87 pump octane (<math>\frac{R+M}{2}</math>) or 91 octane or higher rated by the research method.</li> <li>Gasoline containing MTBE (Methyl Tertiary Butyl Ether), less than 10% ethanol, or less than 5% methanol with appropriate cosolvents and corrosion inhibitor is permissible.</li> </ul>	For U.S.A. model
	Use only unleaded gasoline of at least 87 pump octane ( $\frac{R+M}{2}$ ) or 91 octane or higher rated by the research method.	For Canada model
	Gasoline used should be graded 85-95 octane or higher. An unleaded gasoline is recommended.	For the other models
Fuel tank including reserve	18.5 L (4.8/4.1 US/Imp gal)	For California model
	20.5 L (5.4/4.5 US/Imp gal)	For Switzerland model
	21.0 L (5.5/4.6 US/Imp gal)	For the other models
	reserve 4.5 L (4.8/4.0 US/Imp qt)	For Switzerland and California models
	5.0 L (5.3/4.4 US/Imp qt)	For the other models
Engine oil type	SAE 10W/40, API SE or SF	
Engine oil capacity	Change	4 000 ml (4.2/3.5 US/Imp qt)
	Filter change	4 200 ml (4.4/3.7 US/Imp qt)
	Overhaul	5 100 ml (5.4/4.5 US/Imp qt)
Front fork oil type	Fork oil #5	
Front fork oil capacity (each leg)	*415 ml (14.0/14.6 US/Imp oz)	
Brake fluid type	DOT4	

Asterisk mark (\*) indicates the new L-model specifications.

# TIGHTENING TORQUE

## CHASSIS

ITEM	N-m	kg-m	lb-ft
Steering stem head nut	50 - 80	5.0 - 8.0	36.0 - 58.0
Front fork upper clamp bolt	22 - 35	2.2 - 3.5	16.0 - 25.5
Front fork lower clamp bolt	22 - 35	2.2 - 3.5	16.0 - 25.5
Front fork cap bolt	15 - 30	1.5 - 3.0	11.0 - 21.5
Front fork damper rod bolt	34 - 46	3.4 - 4.6	24.5 - 33.5
Front axle	85 - 115	8.5 - 11.5	61.5 - 83.0
Front axle pinch bolt	18 - 28	1.8 - 2.8	13.0 - 20.0
Handlebar holder mounting bolt	*18 - 28	*1.8 - 2.8	*13.0 - 20.0
Handlebar holder mounting nut	*10 - 16	*1.0 - 1.6	*7.0 - 11.5
Front brake caliper mounting bolt	27 - 43	2.7 - 4.3	19.5 - 31.0
Front brake caliper housing bolt	20 - 25	2.0 - 2.5	14.5 - 18.0
Front brake pad mounting bolt	15 - 20	1.5 - 2.0	11.0 - 14.5
Front brake master cylinder bolt	5 - 8	0.5 - 0.8	3.5 - 6.0
Brake hose union bolt (Cylinder & Caliper)	*15 - 20	*1.5 - 2.0	*11.0 - 14.5
Air bleeder valve (Front & Rear)	6 - 9	0.6 - 0.9	4.5 - 6.5
Front and rear disc bolt	15 - 25	1.5 - 2.5	11.0 - 18.0
Front footrest bracket mounting bolt	27 - 43	2.7 - 4.3	19.5 - 31.0
*Swingarm pivot thrust adjuster lock nut	*60 - 70	*6.0 - 7.0	*43.5 - 50.5
Swingarm pivot nut	85 - 115	8.5 - 11.5	61.5 - 83.0
Front footrest nut	35 - 55	3.5 - 5.5	25.5 - 40.0
Rear shock absorber mounting nut (Upper & Lower)	40 - 60	4.0 - 6.0	29.0 - 43.5
Rear cushion level/rod mounting nut	110 - 160	11.0 - 16.0	79.5 - 115.5
Rear brake caliper mounting bolt	18 - 28	1.8 - 2.8	13.0 - 20.0
Rear brake caliper housing bolt	30 - 36	3.0 - 3.6	21.5 - 26.0
Rear torque link nut (Front & Rear)	22 - 34	2.2 - 3.4	16.0 - 24.5
For E-03,28 and 33	18 - 28	1.8 - 2.8	13.0 - 20.0
Rear brake master cylinder mounting bolt	18 - 28	1.8 - 2.8	13.0 - 20.0
Rear brake rod lock nut	*15 - 20	*1.5 - 2.0	*11.0 - 14.5
Rear axle nut	85 - 115	8.5 - 11.5	61.5 - 83.0
Rear sprocket nut	48 - 72	4.8 - 7.2	35.0 - 52.0

Asterisk mark (\*) indicates the new L-model specifications.

## ENGINE MOUNTING

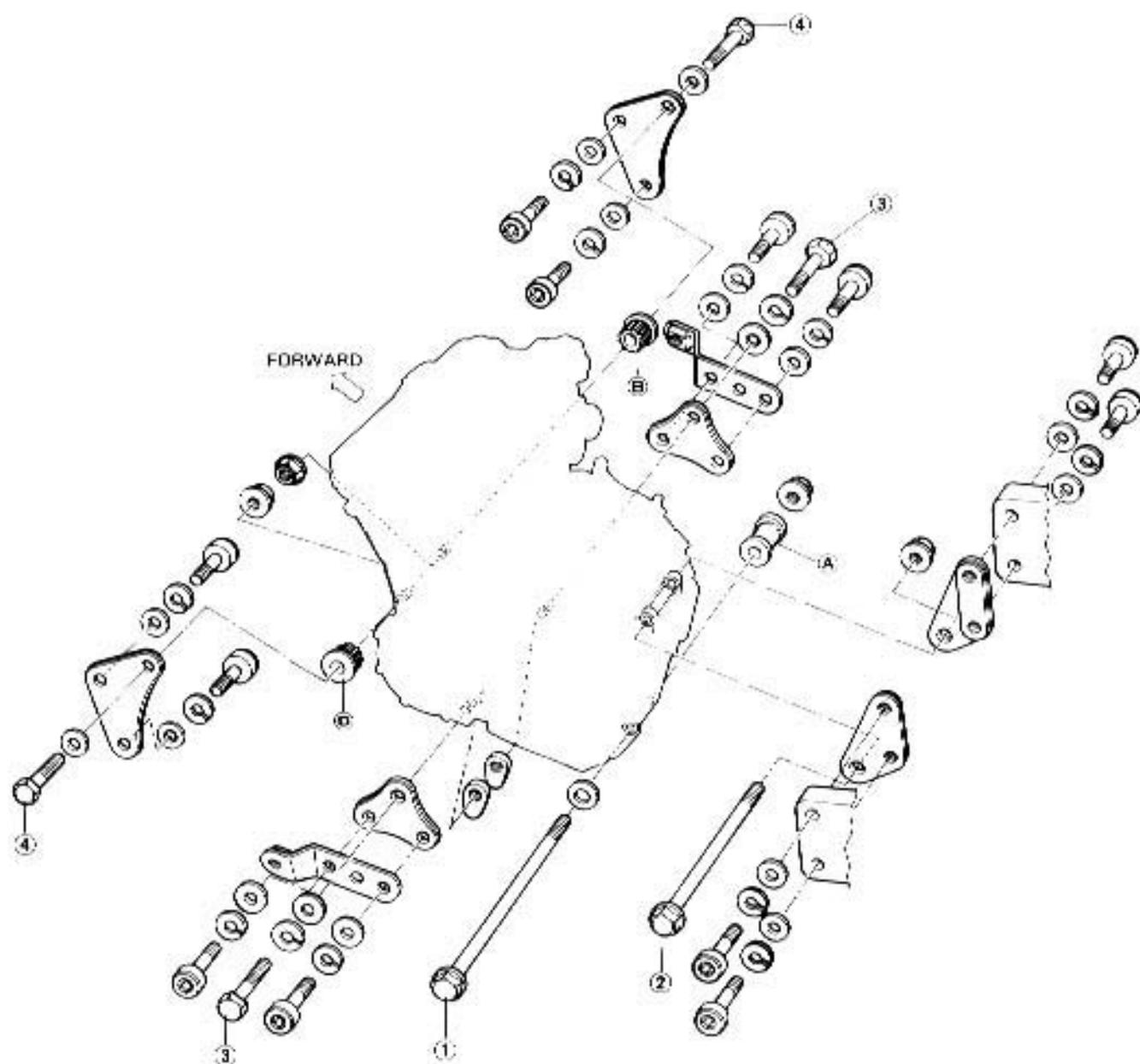

## TIGHTENING TORQUE

ITEM	N·m	kg·m	lb·ft
①, ②	70 - 88	7.0 - 8.8	50.5 - 63.5
③, ④	50 - 60	5.0 - 6.0	36.0 - 43.5
Other bolts	25 - 38	2.5 - 3.8	18.0 - 27.5

## CYLINDER HEAD

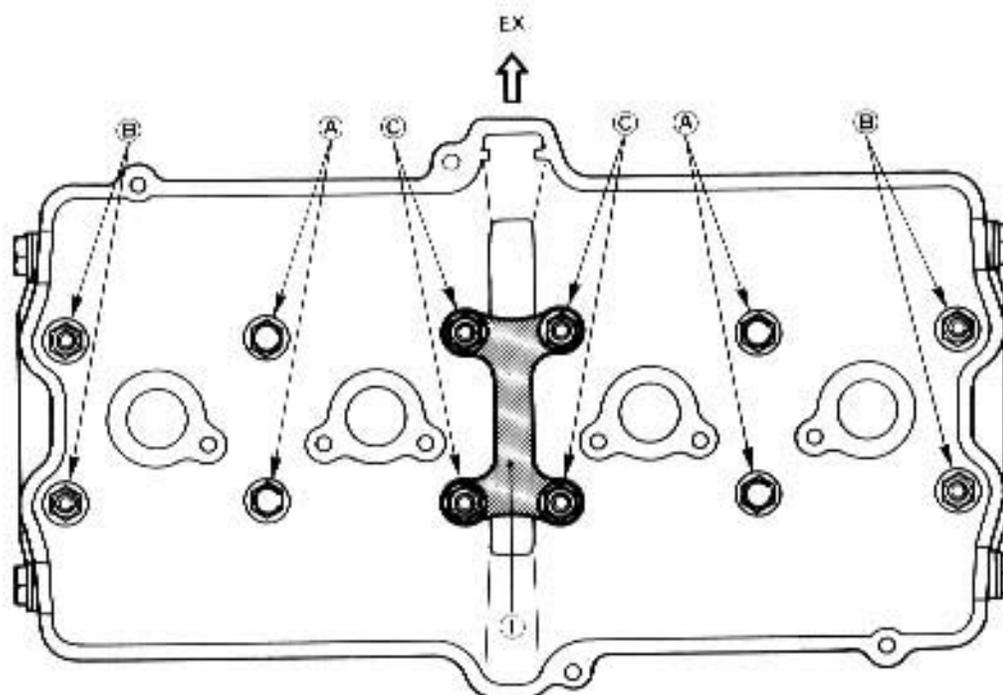

- ① Cylinder head plate Thickness: 3.0 mm (0.12 in)
- Ⓐ Copper washer with cap nut (4 pcs)
- Ⓑ Steel washer with normal nut (4 pcs)
- Ⓒ Copper washer with normal nut (4 pcs)

### CYLINDER HEAD COVER BOLT GASKET

- Before installing the eight gaskets, apply a small quantity of SUZUKI BOND NO. 1207B to both upper and lower sides of the gasket. The purpose of this sealant is to more thoroughly provide oil-tight of the gasket.

99104-31140: SUZUKI BOND NO. 1207B

Head cover bolt

13 - 15 N·m (1.3 - 1.5 kg-m, 9.5 - 11.0 lb-ft)

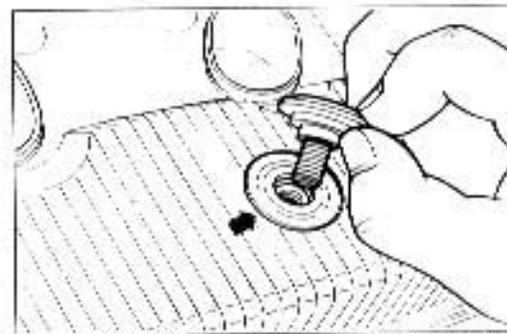

## STEERING

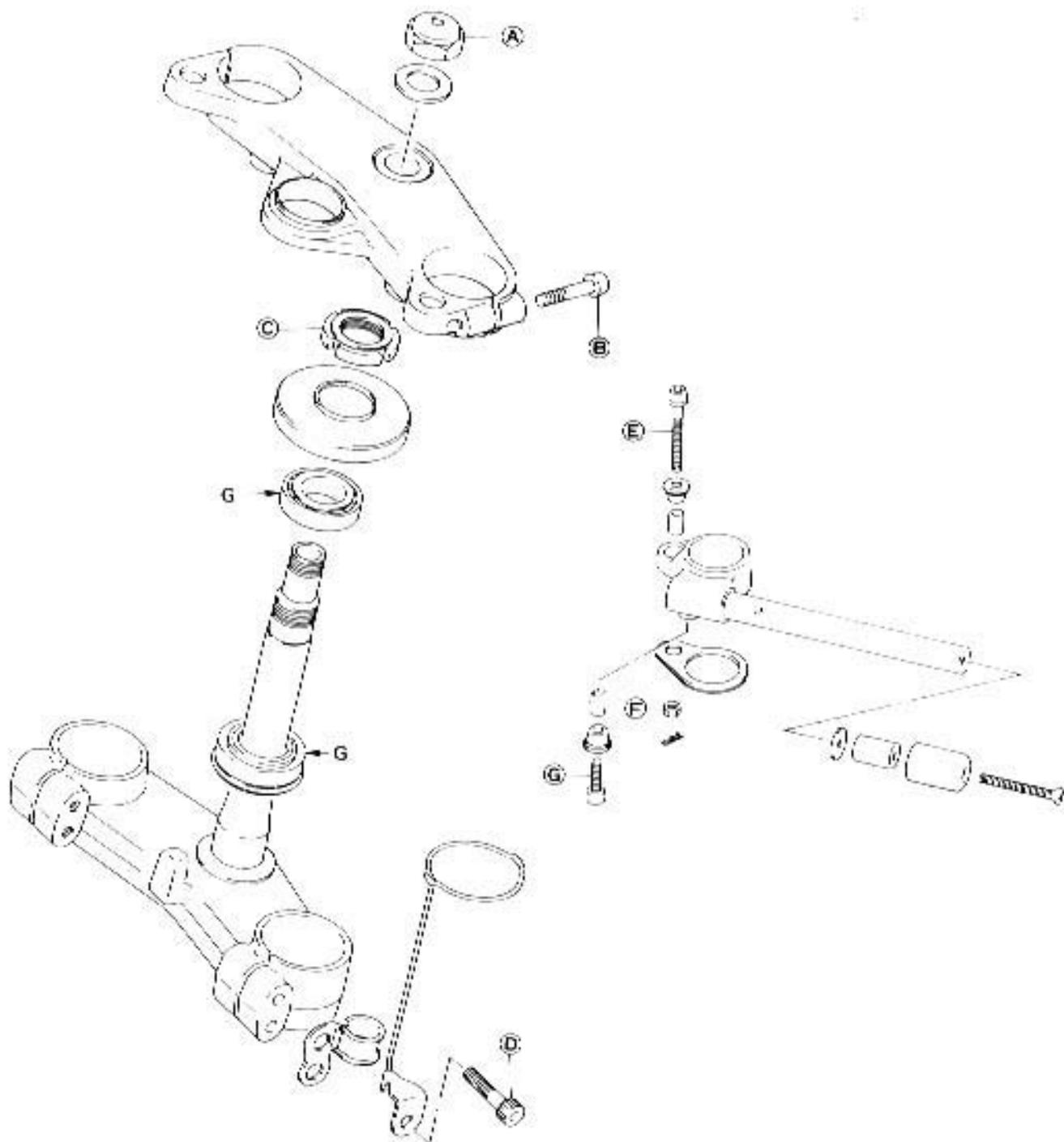

## TIGHTENING TORQUE

ITEM	N·m	kg·m	lb·ft
Ⓐ	50 - 80	5.0 - 8.0	36.0 - 58.0
Ⓑ	22 - 35	2.2 - 3.5	16.0 - 25.5
Ⓒ	40 - 50	4.0 - 5.0	29.0 - 36.0
Ⓓ	22 - 35	2.2 - 3.5	16.0 - 25.5
Ⓔ, Ⓕ	18 - 28	1.8 - 2.8	13.0 - 20.0
Ⓖ	10 - 16	1.0 - 1.6	7.0 - 11.5

G: Apply SUZUKI SUPER GREASE "A".

## SWINGARM

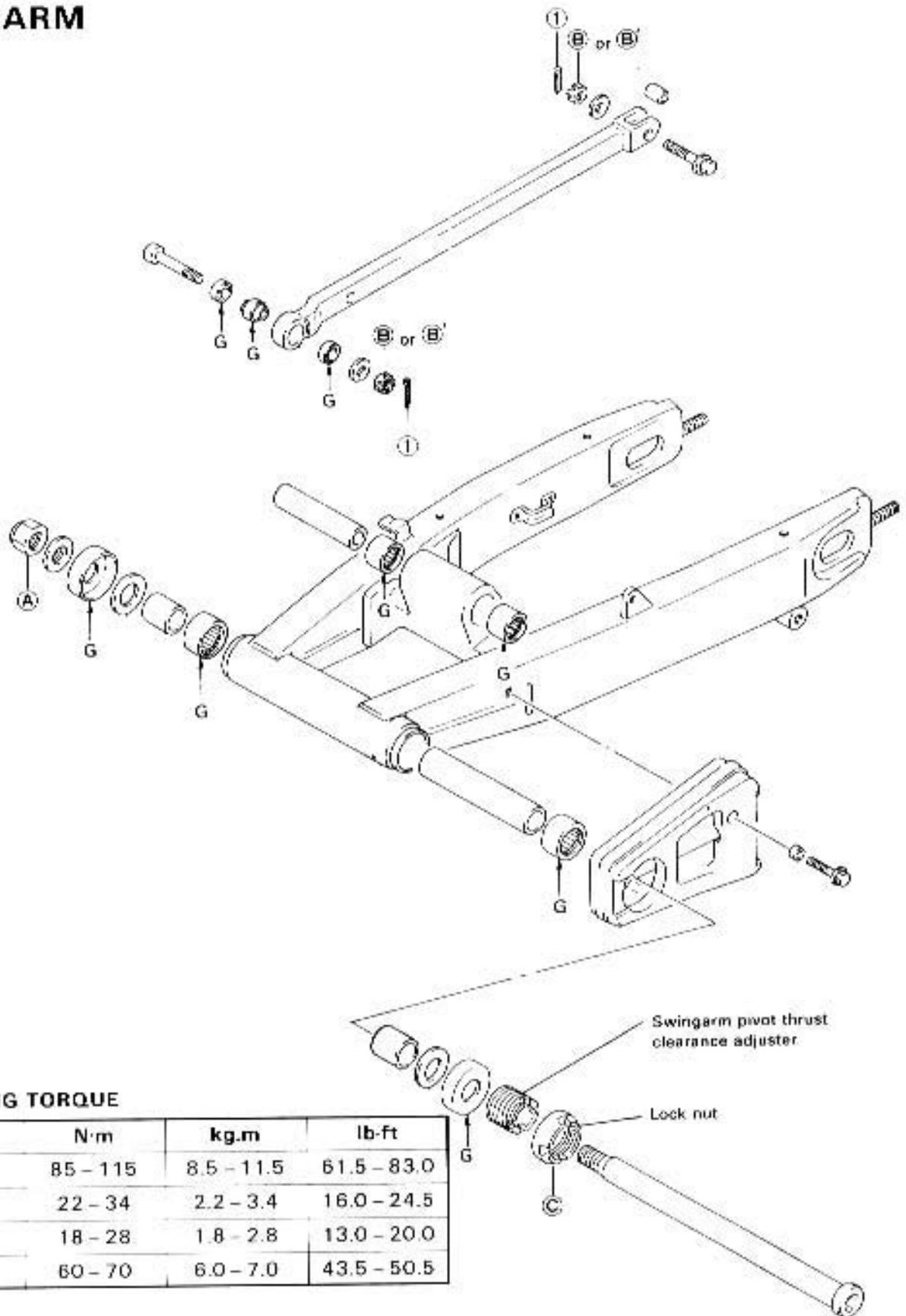

## TIGHTENING TORQUE

ITEM	N·m	kg·m	lb·ft
Ⓐ	85 - 115	8.5 - 11.5	61.5 - 83.0
Ⓑ	22 - 34	2.2 - 3.4	16.0 - 24.5
Ⓑ'	18 - 28	1.8 - 2.8	13.0 - 20.0
Ⓒ	60 - 70	6.0 - 7.0	43.5 - 50.5

Ⓑ': For E-03, 28 and 33 models.

Ⓒ: For the other models.

G: Apply SUZUKI SUPER GREASE "A".

Ⓛ: Cotter Pin (For E-03, 28 and 33 models)



## SWINGARM PIVOT THRUST CLEARANCE ADJUSTMENT

1. Turn in swingarm thrust clearance adjuster along with the swingarm pivot shaft with the special tool (Adjuster turning wrench) until the swingarm pivot thrust clearance adjuster seats onto the dust seal cover.
2. Hold the swingarm pivot shaft with a 14 mm hexagon wrench and tighten the swingarm pivot nut to the specified torque.  
**85 - 115 N·m (8.5 - 11.5 kg·m, 61.5 - 83.0 lb·ft)**
3. Tighten the lock nut to the specified torque.  
**60 - 70 N·m (6.0 - 7.0 kg·m, 43.5 - 50.5 lb·ft)**

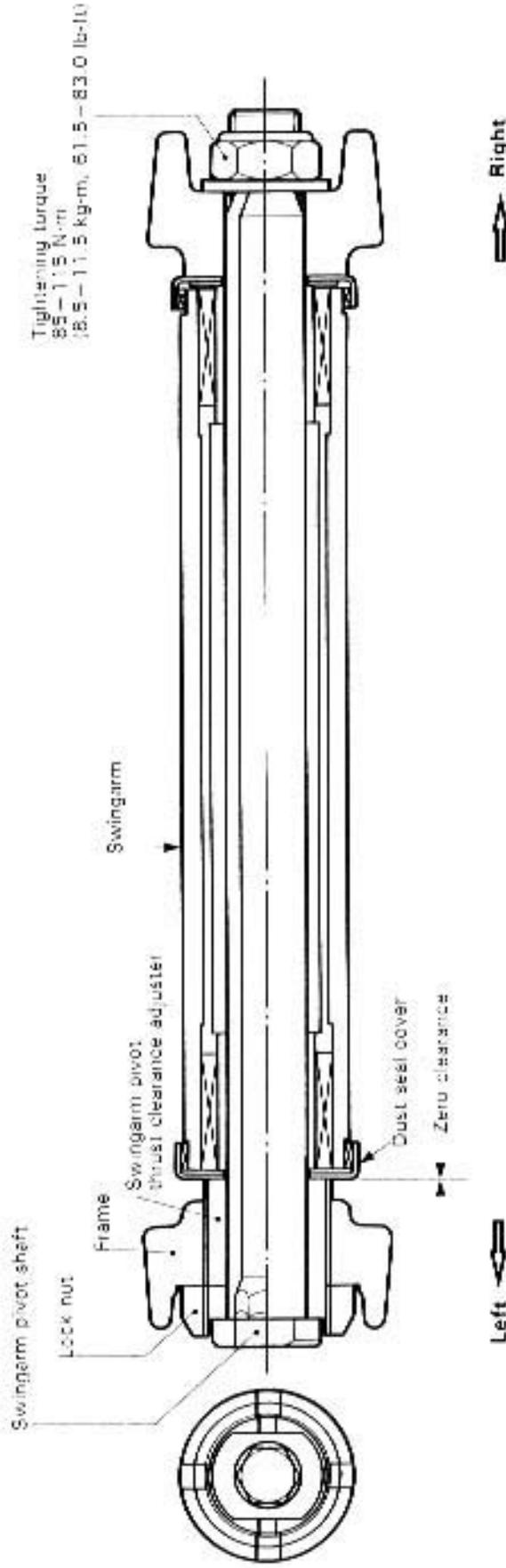

09900 - 18720: 14-mm hexagon wrench  
 09940 - 14940: Adjuster lock nut wrench  
 09940 - 14950: Adjuster turning wrench

## SHOCK ABSORBER AND CUSHION LEVER

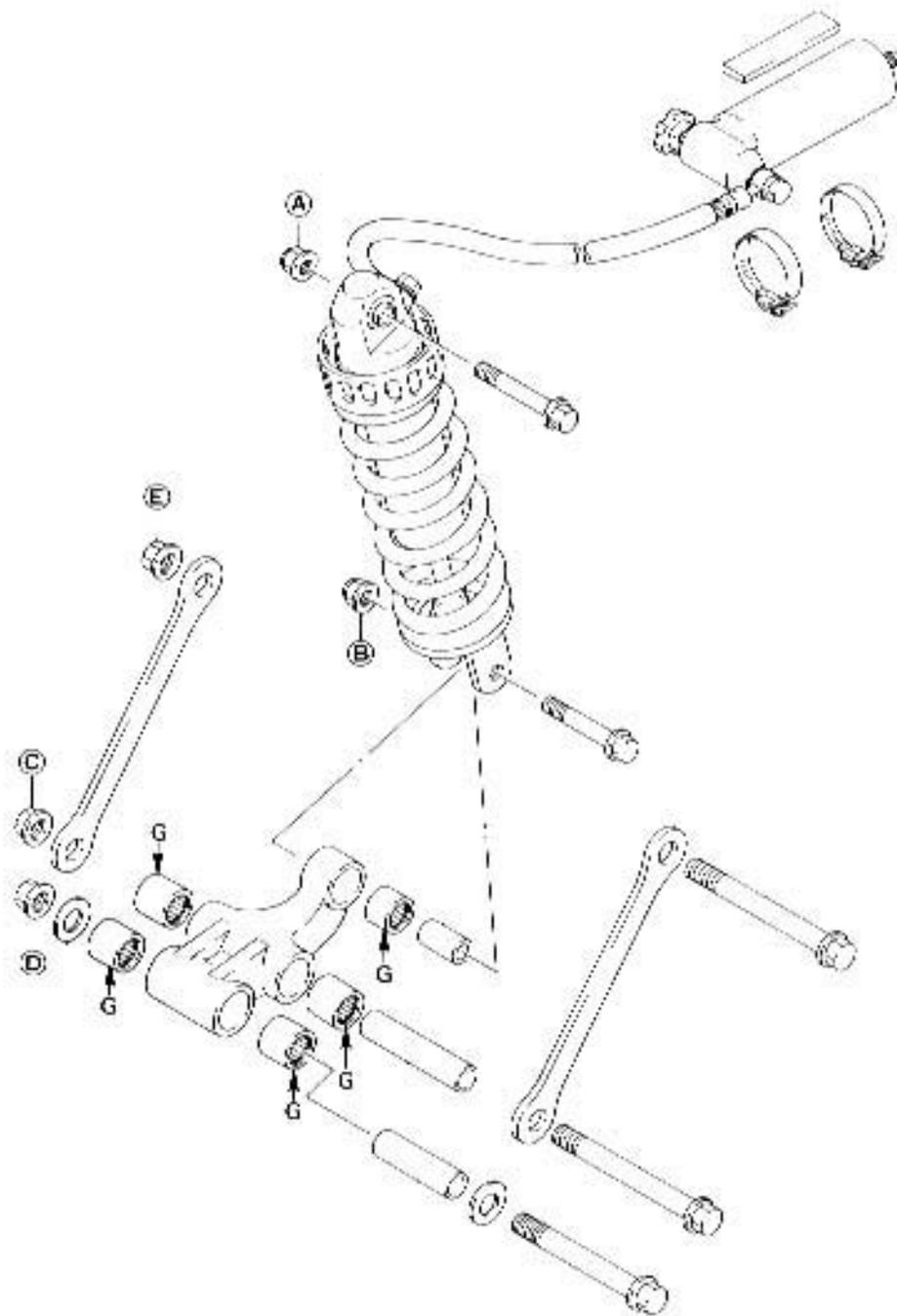

## TIGHTENING TORQUE

ITEM	N·m	kg·m	lb·ft
Ⓐ Ⓑ	40 - 60	4.0 - 6.0	29.0 - 43.5
Ⓒ Ⓓ Ⓔ	110 - 160	11.0 - 16.0	79.5 - 115.5

G: Apply SUZUKI SUPER GREASE "A".

## SUSPENSION SETTING

### FRONT SUSPENSION SETTING TABLE

Item		Spring Pre-load	Damping force	
			Compression	Rebound
Solo riding	Softer	6	3	5
	Standard	5	2	4
	Stiffer	4	1	3
Dual riding		5	2	4

### REAR SUSPENSION SETTING TABLE

Item		Spring Pre-load	Damping force	
			Compression	Rebound
Solo riding	Softer	2	STD setting position - 1 click	STD setting position + 1 click
	Standard	3	STD setting position is stamped on shock absorber body	STD setting position is stamped on shock absorber body
	Stiffer	4	STD setting position - 1 click	STD setting position - 1 click
Dual riding		3	Same as STD setting	Same as STD setting

#### NOTE:

- The rear suspension STD setting position is stamped on the shock absorber body.
- The STD setting position varies a little from each GSX R1100 motorcycle.
- Fully turn the damping force adjuster clockwise it is at 0 position and turn out it to each STD setting position.

"R" is Rebound. "C" is compression.

- (A): Spring adjuster
- (B): Compression adjuster
- (C): Rebound adjuster

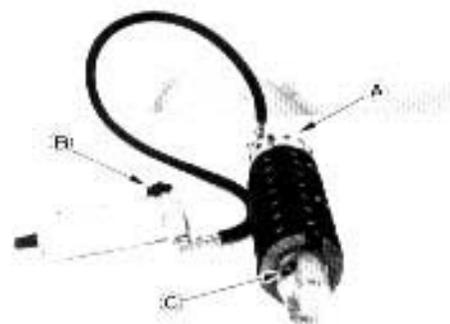

# WIRING DIAGRAM

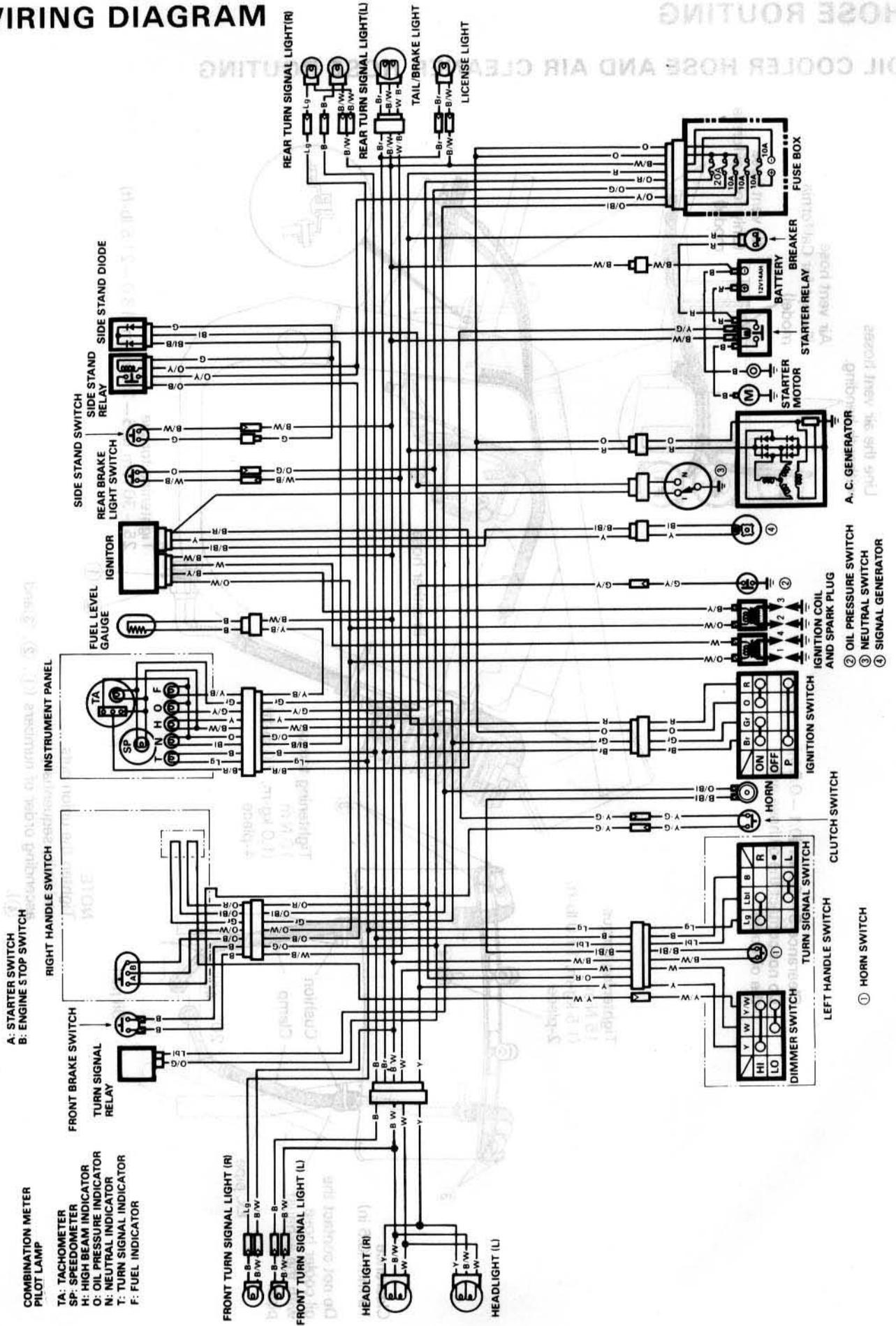

# HOSE ROUTING

## OIL COOLER HOSE AND AIR CLEANER HOSE ROUTING

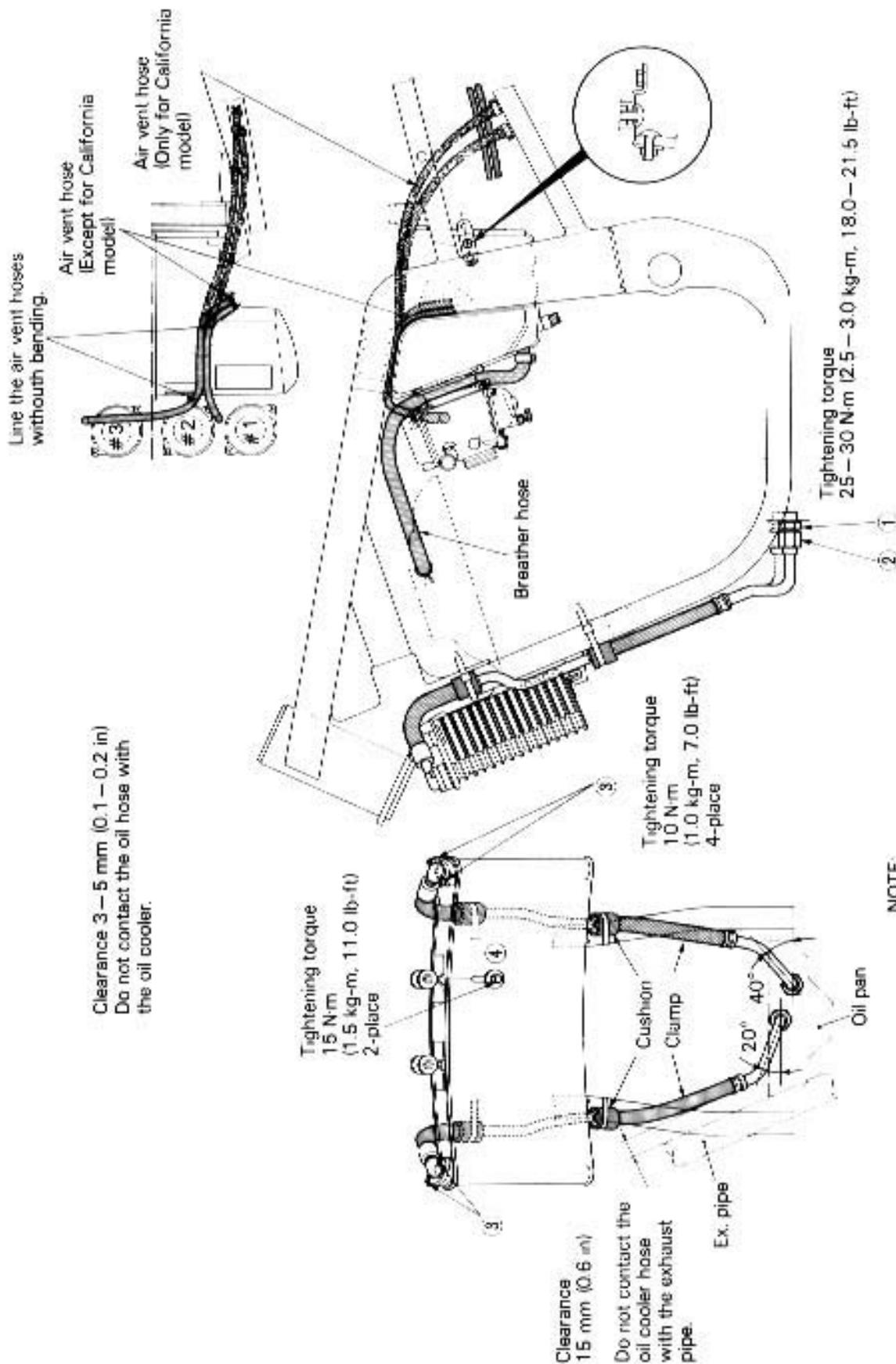

**NOTE:**  
Tighten the union nuts and bolts sequentially in the ascending order of numbers (1), (2), (3) and (4).

### RESERVOIR TANK HOSE ROUTING

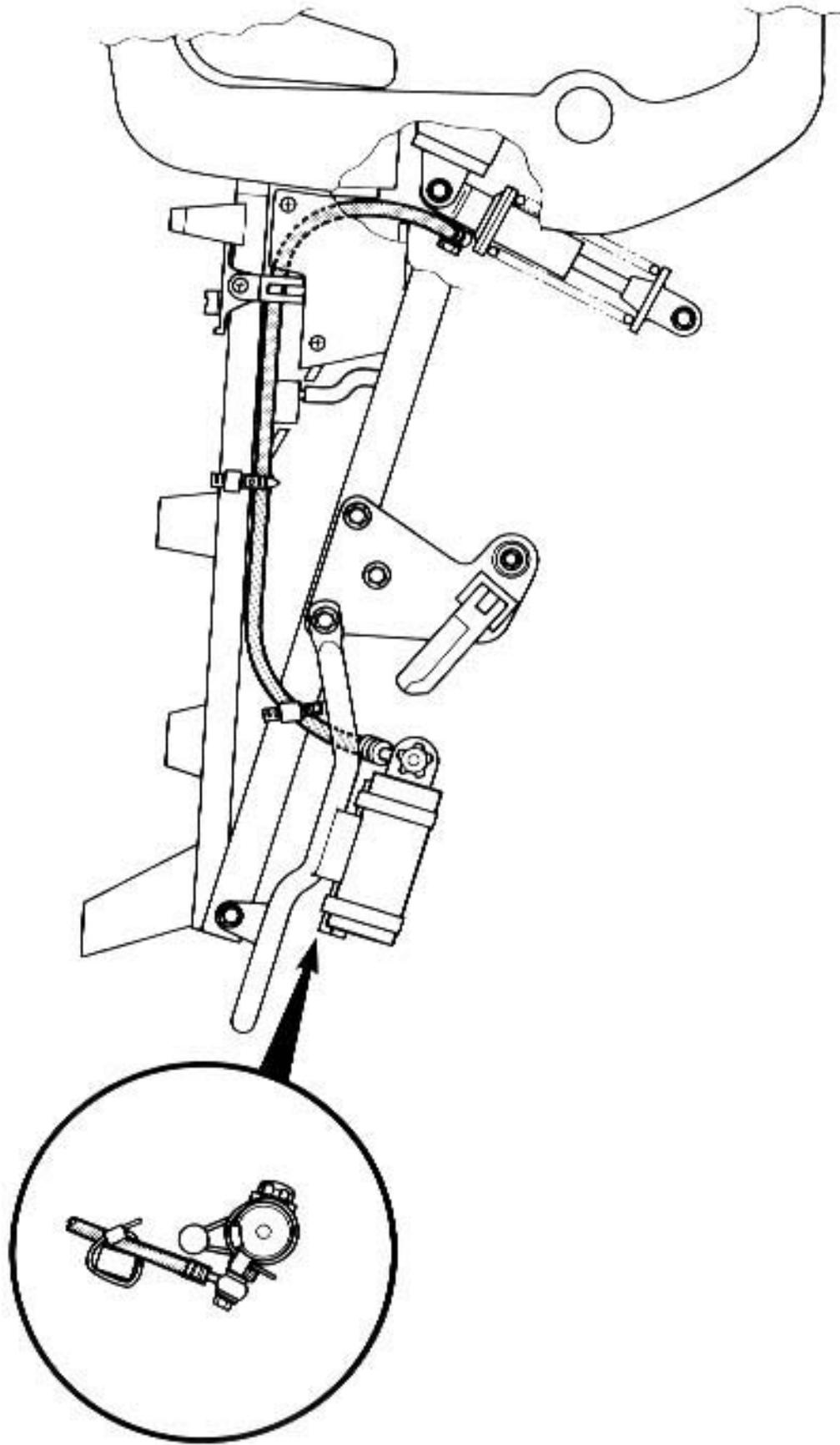

### HIGH TENSION CORD ROUTING (For Switzerland and California models)

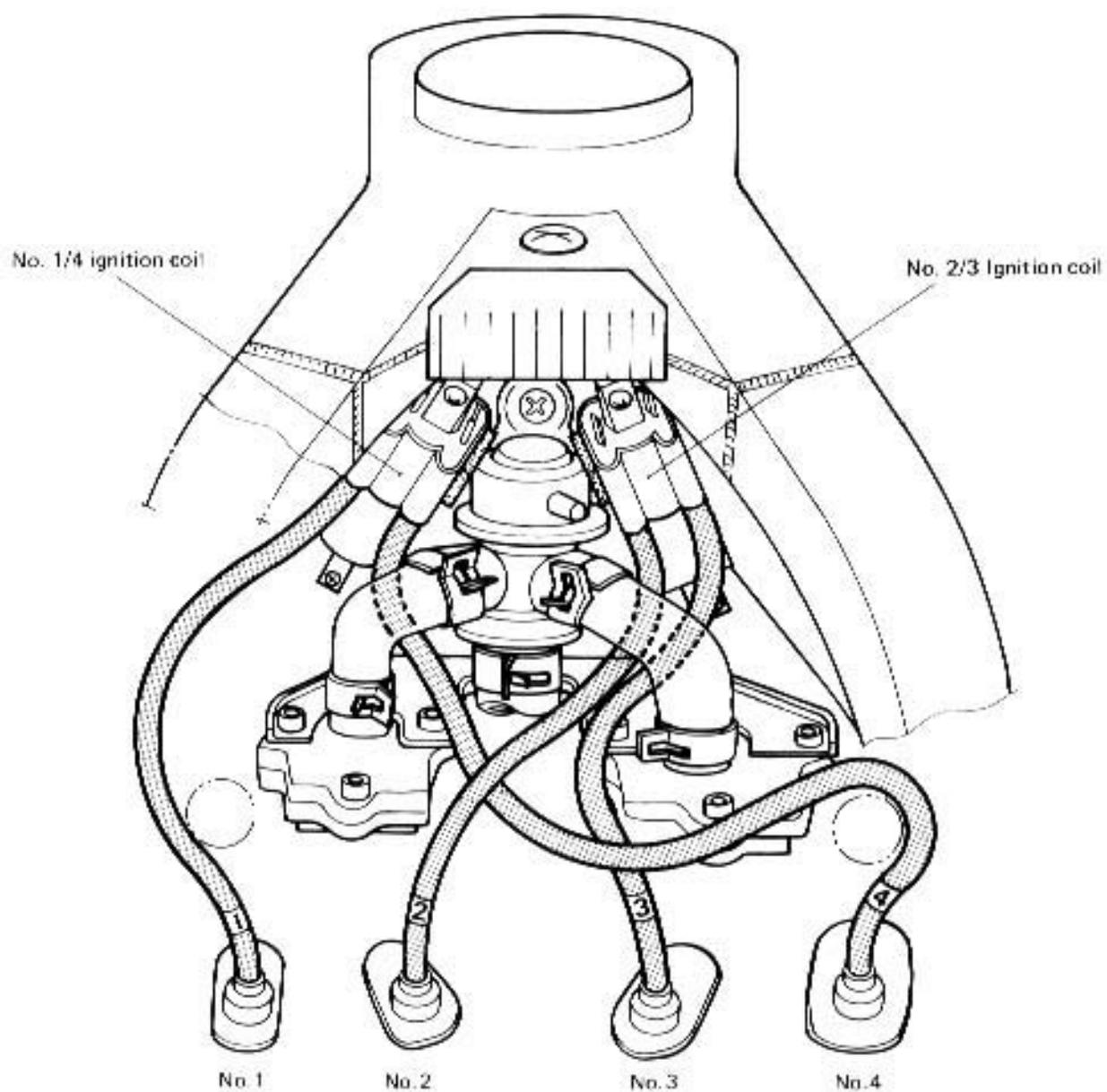

# THROTTLE CABLE ROUTING

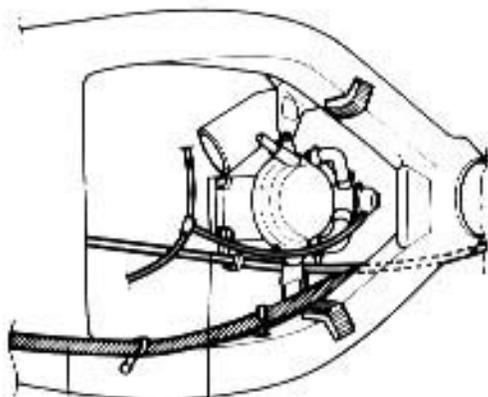

(For California and Switzerland models)

Harness Throttle cable

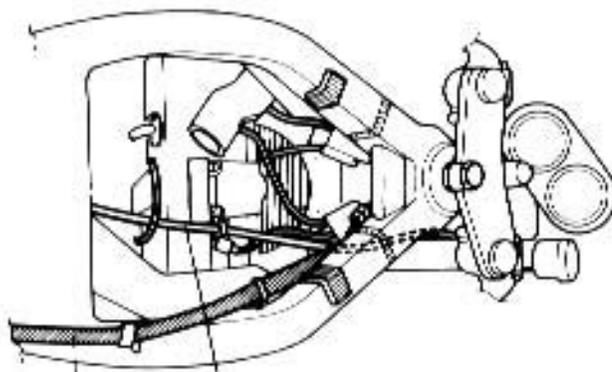

Harness Throttle cable

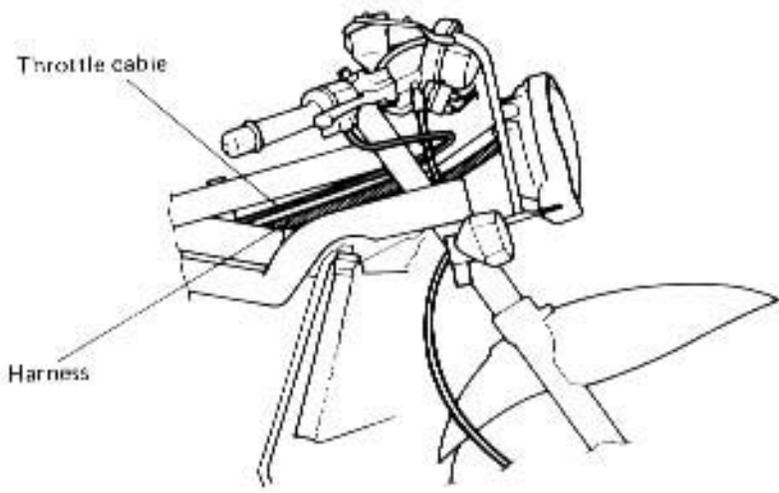

Throttle cable  
Harness



# GSX-R1100M ('91-MODEL)

*This section describes service data, service specifications and servicing procedures which differ from those of the GSX-R1100L ('90-model).*

**NOTE:**

*Any differences between "L" ('90-model) and "M" ('91-model) in specifications and service data are clearly indicated with the asterisk marks (\*). Please refer to the sections 1 through 9 for details which are not given in this section.*

## CONTENTS

<b>SPECIFICATIONS</b> .....	10- 1
<b>SERVICE DATA</b> .....	10- 3
<b>TIGHTENING TORQUE</b> .....	10-14
<b>EMISSION CONTROL CARBURETOR COMPONENTS</b> .....	10-15
<b>ENGINE MOUNTING</b> .....	10-16
<b>CYLINDER HEAD</b> .....	10-17
<b>TAPPET CLEARANCE ADJUSTMENT</b> .....	10-17
<b>TAPPET SHIM SELECTION TABLE (INTAKE)</b> .....	10-18
<b>TAPPET SHIM SELECTION TABLE (EXHAUST)</b> .....	10-19
<b>FRONT FORK</b> .....	10-20
<b>STEERING</b> .....	10-26
<b>SUSPENSION SETTING</b> .....	10-27
<b>WIRING DIAGRAM</b> .....	10-29
<b>WIRE HARNESS ROUTING</b> .....	10-35
<b>FUEL HOSE AND FUEL TANK WATER DRAIN HOSE ROUTING</b> .....	10-38
<b>FRONT BRAKE HOSE ROUTING</b> .....	10-39
<b>REAR BRAKE HOSE ROUTING</b> .....	10-40
<b>CLUTCH HOSE ROUTING</b> .....	10-41
<b>CABLE ROUTING</b> .....	10-43
<b>FAIRING INSTALLATION</b> .....	10-45
<b>FRAME COVER INSTALLATION</b> .....	10-46
<b>ENGINE HEAT PROTECTOR</b> .....	10-47
<b>AIR SUPPLY SYSTEM</b> .....	10-48
<b>AIR SUPPLY HOSE ROUTING</b> .....	10-49
<b>HIGH TENSION CORD ROUTING</b> .....	10-50

## SPECIFICATIONS

### DIMENSIONS AND DRY MASS

Overall length.....	*2135 mm (84.1 in) .... For E-15, 17 models *2215 mm (87.2 in) .... For E-16, 18, 22 models *2085 mm (82.1 in) .... For the other models
Overall width.....	755 mm (29.7 in)
Overall height.....	1150 mm (45.3 in)
Wheelbase.....	1465 mm (57.7 in)
Ground clearance.....	*115 mm (4.5 in)
Dry mass.....	*228 kg (503 lbs) .... For E-33 model *227 kg (500 lbs) .... For E-18, 39 models *226 kg (498 lbs) .... For the other models

### ENGINE

Type.....	Four-stroke, Air-cooled with SACS, DOHC, TSCC
Number of cylinders.....	4
Bore.....	78.0 mm (3.07 in)
Stroke.....	59.0 mm (2.32 in)
Piston displacement.....	1127cm <sup>3</sup> (68.8 cu.in)
Carburetor.....	MIKUNI BST36SS, four .... For E-03, 18, 33, 39 models *MIKUNI BST40SS, four ... For the other models
Air cleaner.....	Polyester fiber element
Starter system.....	Electric starter
Lubrication system.....	Wet sump

### TRANSMISSION

Clutch.....	Wet multi-plate type, hydraulically operated
Transmission.....	5-speed constant mesh
Gearshift pattern.....	1-down, 4-up
Primary reduction.....	1.565 (72/46)
Final reduction.....	3.200 (48/15)
Gear ratios, Low.....	2.384 (31/13)
2nd.....	1.631 (31/19)
3rd.....	1.250 (25/20)
4th.....	1.045 (23/22)
Top.....	0.913 (21/23)
Drive chain.....	TAKASAGO RK532GSVz, 118 links

## CHASSIS

Front suspension.....	Inverted telescopic, coil spring, oil damped, inner rod type, spring pre-load fully adjustable, damping force compression 8-way and rebound 10-way adjustable.
Rear suspension.....	Link type system, gas/oil damped, coil spring, spring pre-load 7-way adjustable, damping force compression 17-way and rebound 19-way adjustable
Steering angle.....	30° (right & left)
Caster.....	*64°10'
Trail.....	*91 mm (3.6in)
Turning radius.....	3.2 m (10.5ft)
Front brake.....	Disc brake, twin
Rear brake.....	Disc brake
Front tire size.....	*120/70ZR17
Rear tire size.....	180/55ZR17
Front fork stroke.....	120mm (4.7in)
Rear wheel travel.....	158mm (6.2in)

## ELECTRICAL

Ignition type.....	Fully Transistorized
Ignition timing.....	7° B.T.D.C. at 1500 r/min..... For E-33 model 13° B.T.D.C. at 1500 r/min..... For the other models
Spark plug.....	N.G.K.: JR9B
Battery.....	12V 50.4 kC (14Ah)/10HR
Generator.....	Three-phase A.C. Generator
Fuse.....	10/10/10/10/10A..... For E-34 model 20/10/10/10/10A..... For the other models
Circuit breaker.....	30A

## CAPACITIES

Fuel tank, including reserve.....	*20.0 L (5.3/4.4 US/Imp gal)..... For E-18, 39 models 18.5 L (4.8/4.1 US/Imp gal)..... For E-33 model *22.0 L (5.8/4.8 US/Imp gal)..... For the other models
Engine oil, Oil change with oil filter change.....	4.2 L (4.4/3.7 US/Imp qt)
Front fork oil.....	398 ml (13.5/14.0 US/Imp oz)

These specifications are subject to change without notice.  
Asterisk mark(\*) indicates the new M-model specifications.

E-39: Austria
E-34: Italy
E-33: California (U.S.A.) model
E-03: U.S.A. model
E-17: Sweden model
E-18: Switzerland model

## SERVICE DATA

## VALVE + GUIDE

Unit: mm (in)

ITEM	STANDARD		LIMIT
Valve diam.	IN.	28.5 (1.12)	—
	EX.	25 (1.0)	—
Valve lift	IN.	8.8 (0.35)	—
	EX.	8.2 (0.32)	—
Valve clearance (when cold)	IN.	*0.10 – 0.20 (0.004 – 0.008)	—
	EX.	*0.15 – 0.25 (0.006 – 0.010)	—
Valve guide to valve stem clearance	IN.	0.020 – 0.047 (0.0008 – 0.0019)	0.35 (0.014)
	EX.	0.040 – 0.067 (0.0016 – 0.0026)	0.35 (0.014)
Valve guide I.D.	IN. & EX.	5.000 – 5.012 (0.1969 – 0.1973)	—
Valve stem O.D.	IN.	4.965 – 4.980 (0.1955 – 0.1961)	—
	EX.	4.945 – 4.960 (0.1947 – 0.1953)	—
Valve stem runout	IN. & EX.	—	0.05 (0.002)
Valve head thickness	IN. & EX.	—	0.5 (0.02)
Valve seat width	IN. & EX.	0.9 – 1.1 (0.035 – 0.043)	—
Valve head radial runout	IN. & EX.	—	0.03 (0.001)
Valve spring free length (IN. & EX.)	INNER	—	*39.4 (1.55)
	OUTER	—	*41.8 (1.65)
Valve spring tension (IN. & EX.)	INNER	*5.3 – 6.5 kg (11.7 – 14.3 lbs) at length 31 mm (1.2 in)	—
	OUTER	*13.1 – 15.1 kg (28.9 – 33.3 lbs) at length 34.5 mm (1.4 in)	—

Asterisk mark(\*) indicates the new M-model specifications.

## CAMSHAFT + CYLINDER HEAD

Unit: mm (in)

ITEM		STANDARD		LIMIT
Cam height	E-01, 03, 28, 33, 34	IN.	*33.922 – 33.978 (1.3355 – 1.3377)	*33.630 (1.3240)
	Others		*33.892 – 33.948 (1.3343 – 1.3365)	*33.600 (1.3228)
	E-01, 03, 28, 33, 34	EX.	*33.632 – 33.688 (1.3241 – 1.3263)	*33.340 (1.3126)
	Others		*33.612 – 33.668 (1.3233 – 1.3255)	*33.320 (1.3118)
Camshaft journal oil clearance		IN. & EX.	0.032 – 0.066 (0.0013 – 0.0026)	0.150 (0.0059)
Camshaft journal holder I.D.		IN. & EX.	22.012 – 22.025 (0.8666 – 0.8671)	—
Camshaft journal O.D.		IN. & EX.	21.959 – 21.980 (0.8645 – 0.8654)	—
Camshaft runout		IN. & EX.	—	0.10 (0.004)
Cam chain 20-pitch length		—		158.0 (6.22)
Cam chain pin (at arrow "3")		22nd pin		—
Rocker arm I.D.		IN. & EX.	12.000 – 12.018 (0.4724 – 0.4731)	—
Rocker arm shaft O.D.		IN. & EX.	11.973 – 11.984 (0.4714 – 0.4718)	—
Cylinder head distortion		—		0.20 (0.008)

## CYLINDER + PISTON + PISTON RING

Unit: mm (in)

ITEM	STANDARD	LIMIT
Compression pressure	1 200 – 1 400 kPa 12 – 14 kg/cm <sup>2</sup> 170 – 199 psi	1 000 kPa 10 kg/cm <sup>2</sup> 142 psi
Compression pressure difference	—	200 kPa 2 kg/cm <sup>2</sup> 28 psi
Piston to cylinder clearance	0.050 – 0.060 (0.0020 – 0.0024)	0.120 (0.0047)
Cylinder bore	78.000 – 78.015 (3.0709 – 3.0715)	78.080 (3.0740)
Piston diam.	77.945 – 77.960 (3.0687 – 3.0693) Measure at 15 mm (0.6 in) from the skirt end.	77.880 (3.0661)
Cylinder distortion	—	0.20 (0.008)

Asterisk mark (\*) indicates the new M-model specifications.

Unit: mm (in)

ITEM	STANDARD		LIMIT	
Piston ring free end gap	1st	N	Approx. 10 (0.39)	8 (0.31)
	2nd	N	Approx. 11.5 (0.45)	9.2 (0.36)
Piston ring end gap	1st		0.20 - 0.35 (0.008 - 0.014)	0.7 (0.03)
	2nd		0.35 - 0.50 (0.014 - 0.020)	1.0 (0.04)
Piston ring to groove clearance	1st		—	0.180 (0.007)
	2nd		—	0.150 (0.006)
Piston ring groove width	1st		1.01 - 1.03 (0.040 - 0.041)	—
	2nd		1.01 - 1.03 (0.040 - 0.041)	—
	Oil		2.01 - 2.03 (0.079 - 0.080)	—
Piston ring thickness	1st		0.97 - 0.99 (0.038 - 0.039)	—
	2nd		0.97 - 0.99 (0.038 - 0.039)	—
Piston pin bore			20.002 - 20.008 (0.7875 - 0.7877)	20.030 (0.7886)
Piston pin O.D.			19.996 - 20.000 (0.7872 - 0.7874)	19.980 (0.7866)

**CONROD + CRANKSHAFT**

Unit: mm (in)

ITEM	STANDARD	LIMIT
Conrod small end I.D.	20.010 - 20.018 (0.7878 - 0.7881)	20.040 (0.7890)
Conrod big end side clearance	0.10 - 0.20 (0.004 - 0.008)	0.30 (0.01)
Conrod big end width	20.95 - 21.00 (0.825 - 0.827)	—
Crank pin width	21.10 - 21.15 (0.831 - 0.833)	—
Conrod big end oil clearance	0.032 - 0.056 (0.0013 - 0.0022)	0.080 (0.0031)
Crank pin O.D.	37.976 - 38.000 (1.4951 - 1.4961)	—
Crankshaft journal oil clearance	0.020 - 0.044 (0.0008 - 0.0017)	0.080 (0.0031)
Crankshaft journal O.D.	35.976 - 36.000 (1.4164 - 1.4173)	—

Unit: mm (in)

ITEM	STANDARD		LIMIT
Crankshaft thrust clearance	0.05 – 0.13 (0.002 – 0.005)		—
Crankshaft thrust bearing thickness	Left side	2.36 – 2.48 (0.093 – 0.098)	—
	Right side	2.42 – 2.44 (0.095 – 0.096)	—
Crankshaft runout	—		0.05 (0.002)

**OIL PUMP**

ITEM	STANDARD	LIMIT
Oil pump reduction ratio	1.819 (72/46 × 43/37)	—
Oil pressure (at 60°C, 140°F)	Above 300 kPa (3.0 kg/cm <sup>2</sup> , 43 psi) Below 600 kPa (6.0 kg/cm <sup>2</sup> , 85 psi) at 3 000 r/min.	—

**CLUTCH**

Unit: mm (in)

ITEM	STANDARD	LIMIT
Drive plate thickness	2.52 – 2.68 (0.100 – 0.106)	2.22 (0.087)
Driven plate distortion	—	0.10 (0.004)
Clutch spring free height	—	3.1 (0.12)
Clutch master cylinder bore	14.000 – 14.043 (0.5511 – 0.5529)	—
Clutch master cylinder piston diam.	13.957 – 13.984 (0.5495 – 0.5506)	—
Clutch release cylinder bore	35.700 – 35.762 (1.4055 – 1.4079)	—
Clutch release cylinder piston diam.	35.650 – 35.675 (1.4035 – 1.4045)	—

## TRANSMISSION + DRIVE CHAIN

Unit: mm (in) Except ratio

ITEM		STANDARD	LIMIT
Primary reduction ratio		1.565 (72/46)	—
Final reduction ratio		3.200 (48/15)	—
Gear ratios	Low	2.384 (31/13)	—
	2nd	1.631 (31/19)	—
	3rd	1.250 (25/20)	—
	4th	1.045 (23/22)	—
	Top	0.913 (21/23)	—
Shift fork to groove clearance	No.1, No.2 & No.3	0.1 - 0.3 (0.004 - 0.012)	0.50 (0.020)
Shift fork groove width	No.1, No.2 & No.3	5.0 - 5.1 (0.197 - 0.201)	—
Shift fork thickness	No.1, No.2 & No.3	4.8 - 4.9 (0.189 - 0.193)	—
Drive chain	Type	TAKASAGO:RK532GSV2	—
	Links	118 links	—
	20 - pitch length	—	319.4 (12.6)
Drive chain slack		25 - 35 (1.0 - 1.4)	—
Gearshift lever height		65 (2.6)	—

## \*CARBURETOR

ITEM	SPECIFICATION			
	E-01	E-02,16,21, 25,28,53	E-04	E-22
Carburetor type	MIKUNI BST40SS	←	←	←
Bore size	40 mm (1.6 in)	←	←	←
I.D.No.	41C0	41C4	42C2	41C6
Idle r/min.	1100 ± 100 r/min	←	←	←
Float height	14.7 ± 1.0 mm (0.57 ± 0.04 in)	←	←	←
Main jet (M.J.)	#125	←	←	←
Main air jet (M.A.J.)	1.2 mm	←	←	←
Jet needle (J.N.)	6ZD13-3rd	←	←	←
Needle jet (N.J.)	P-2	←	←	←
Pilot jet (P.J.)	#40	←	←	←
By-pass (B.P.)	0.8 mm	←	←	←



Pilot outlet (P.O.)	0.7 mm	←	←	←
Valve seat (V.S.)	2.5 mm	←	←	←
Starter jet (G.S.)	#40	←	←	←
Pilot screw (P.S.)	PRE-SET (2 turns out)	←	←	PRE-SET (1 3/4 turns out)
Throttle cable play	0.5 – 1.0 mm (0.02 – 0.04 in)			

## \*CARBURETOR

ITEM	SPECIFICATION			
	E-34	E-15	E-17	E-24
Carburetor type	MIKUNI BST40SS	←	←	←
Bore size	40 mm (1.6 in)	←	←	←
I.D.No.	42C0	42C1	41C5	41C9
Idle r/min.	1100 ± 100 r/min	←	←	←
Float height	14.7 ± 1.0 mm (0.57 ± 0.04 in)	←	←	←
Main jet (M.J.)	#125	←	←	←
Main air jet (M.A.J.)	1.2 mm	←	←	←
Jet needle (J.N.)	6ZD13-3rd	←	←	←
Needle jet (N.J.)	P-2	←	←	←
Pilot jet (P.J.)	#40	←	←	←
By-pass (B.P.)	0.8 mm	←	←	←
Pilot outlet (P.O.)	0.7 mm	←	←	←
Valve seat (V.S.)	2.5 mm	←	←	←
Starter jet (G.S.)	#40	←	←	←
Pilot screw (P.S.)	PRE-SET (2 turns out)	←	←	←
Throttle cable play	0.5 – 1.0 mm (0.02 – 0.04 in)			

Asterisk mark (\*) indicates the new M-model specifications.

## \*CARBURETOR

ITEM	SPECIFICATION			
	E-03	E-33	E-18	E-39
Carburetor type	MIKUNI BST36SS	←	←	←
Bore size	36 mm (1.4 in)	←	←	←
I.D.No.	41C1	41C2	41C3	41C7
Idle r/min.	1200 ± 100 r/min	1100 ± 100 r/min	1100 ± $\frac{100}{95}$ r/min	1100 ± 100 r/min
Float height	14.6 ± 1.0 mm (0.57 ± 0.04 in)	←	←	←
Main jet (M.J.)	# 122.5	←	# 110	# 122.5
Main air jet (M.A.J.)	1.5 mm	←	←	←
Jet needle (J.N.)	5D42	5D43	5D44-3rd	←
Needle jet (N.J.)	0-8	←	0-9	←
Pilot jet (P.J.)	# 30	←	# 30	←
By-pass (B.P.)	0.8 mm	←	←	←
Pilot outlet (P.O.)	0.7 mm	←	←	←
Valve seat (V.S.)	2.3 mm	←	←	←
Starter jet (G.S.)	# 42.5	←	←	←
Pilot screw (P.S.)	PRE-SET	←	PRE-SET (1 1/4 turns out)	PRE-SET (1 1/2 turns out)
Throttle cable play	0.5 - 1.0 mm (0.02 - 0.04 in)	←	←	←

## ELECTRICAL

Unit: mm (in)

ITEM	SPECIFICATION		NOTE
Ignition timing	13° B.T.D.C. at 1 500 r/min		
	7° B.T.D.C. at 1 500 r/min		California model only
Firing order	1.2.4.3		
Spark plug	Type	NGK: JR9B	JR10B (OPT. Cold type)
	Gap	0.6 - 0.7 (0.024 - 0.028)	
Spark performance	Over 8 (0.3) at 1 atm.		
Signal coil resistance	Approx. 135 - 200Ω		Tester range: (× 100Ω)
Ignition coil resistance	Primary	⊕ tap - ⊖ tap Approx. 2.4 - 3.2Ω	Tester range: (× 1Ω)
	Secondary	Plug cap - Plug cap Approx. 30 - 40 kΩ	Tester range: (× 1kΩ)
Generator	Slip ring O.D.	Limit: 14.0 (0.55)	N.D.
	Brush length	Limit: 4.5 (0.18)	
Generator Max. output	Approx. 337.5 W at 5000 r/min		The rotation of the generator

Unit: mm (in)

ITEM		SPECIFICATION		NOTE
Regulated voltage		Above 13.5V at 5 000 r/min.		
Starter motor		Brush length	Limit: 6 (0.2)	MITSUBA
		Commutator under-cut	Limit: 0.2 (0.008)	
Starter relay resistance		3 - 5 $\Omega$		
Battery	Type designation	YB14L-A2		
	Capacity	12V 50.4 kC (14Ah)/10HR		
	Standard electrolyte S.G.	1.28 at 20°C (68°F)		
Fuse size	Headlight	20A (10A ... Only E-34)		
	Turn signal	10A		
	Ignition	10A		
	Taillight	10A		
	Power source	10A		
Circuit breaker		30A		

**WATTAGE**

Unit: W

ITEM		SPECIFICATION				
		E-01, 02, 16, 18, 21, 24	E-03, 28, 33	E-04, 16, 17, 18, 21, 22, 25, 39, 53	E-15	E-34
Headlight	HI	60×2pcs.	←	60+55	60×2pcs.	35×2pcs.
	LO	55×2pcs.	←	55	←	35×2pcs.
Position light		*5	←	←	←	←
Tail/Brake light		5/21×2PCS	←	←	←	←
Turn signal light		21	←	←	←	←
Tachometer light		3	←	←	←	←
Speedometer light		3	←	←	←	←
Fuel level indicator light		3	←	←	←	←
Turn signal indicaotr light		3	←	←	←	←
High beam indicaotr light		1.7	←	←	←	←
Neutral indicaotr light		3	←	←	←	←
Oil pressure indicator light		1.7	←	←	←	←
License light		5	←	←	←	←

Asterisk mark (\*) indicates the new M-model specifications.

## BRAKE + WHEEL

Unit: mm (in)

ITEM		STANDARD		LIMIT
Rear brake pedal height		65 (2.6)		—
Brake disc thickness	Front	5.0 ± 0.2 (0.197 ± 0.008)		4.5 (0.18)
	Rear	6.0 ± 0.2 (0.236 ± 0.008)		5.5 (0.22)
Brake disc runout		—		0.30 (0.012)
Master cylinder bore	Front	14.000 - 14.043 (0.5511 - 0.5529)		—
	Rear	12.700 - 12.743 (0.5000 - 0.5017)		—
Master cylinder piston diam.	Front	13.957 - 13.984 (0.5495 - 0.5506)		—
	Rear	12.657 - 12.684 (0.4983 - 0.4994)		—
Brake caliper cylinder bore	Trailing	Front	33.960 - 34.010 (1.3370 - 1.3390)	—
			Leading	30.230 - 30.280 (1.1902 - 1.1921)
	Rear	38.180 - 38.256 (1.5031 - 1.5061)	—	
Brake caliper piston diam.	Trailing	Front	33.878 - 33.928 (1.3338 - 1.3357)	—
			Leading	30.130 - 30.180 (1.1862 - 1.1882)
	Rear	38.098 - 38.148 (1.5000 - 1.5019)	—	
Wheel rim runout	Axial	—		2.0 (0.08)
	Radial	—		2.0 (0.08)
Wheel axle runout	Front	—		0.25 (0.010)
	Rear	—		0.25 (0.010)
Tire size	Front	*120/70 ZR17		—
	Rear	180/55 ZR17		—
Tire tread depth	Front	—		1.6 (0.06)
	Rear	—		2.0 (0.08)

Asterisk mark (\*) indicates the new M-model specifications.

**SUSPENSION**

Unit: mm (in)

ITEM	STANDARD	LIMIT	NOTE
Front fork stroke	120 (4.7)	—	
Front fork spring free length	—	277 (10.9)	
Front fork oil level	131 (5.16)	—	
Rear wheel travel	158 (6.2)	—	
Swingarm pivot shaft runout	—	0.3 (0.01)	

**\*TIRE PRESSURE**

COLD INFLATION TIRE PRESSURE	SOLO RIDING			DUAL RIDING		
	kPa	kg/cm <sup>2</sup>	psi	kPa	kg/cm <sup>2</sup>	psi
FRONT	230	2.30	33	230	2.30	33
REAR	250	2.50	36	250	2.50	36

Asterisk mark (\*) indicates the new M-model specifications.

## FUEL + OIL

ITEM	SPECIFICATION		NOTE
Fuel type	<ul style="list-style-type: none"> <li>Use only unleaded gasoline of at least 87 pump octane (<math>\frac{R+M}{2}</math>) or 91 octane or higher rated by the research method.</li> <li>Gasoline containing MTBE (Methyl Tertiary Butyl Ether), less than 10% ethanol, or less than 5% methanol with appropriate cosolvents and corrosion inhibitor is permissible.</li> </ul>		For U.S.A. model
	Use only unleaded gasoline of at least 87 pump octane ( $\frac{R+M}{2}$ ) or 91 octane or higher rated by the research method.		For Canada model
	Gasoline used should be graded 85-95 octane or higher. An unleaded gasoline is recommended.		For the other models
Fuel tank including reserve	18.5 L (4.8/4.1 US/Imp gal)		For California model
	*20.0 L (5.3/4.4 US/Imp gal)		For Switzerland and Austria models
	*22.0 L (5.8/4.8 US/Imp gal)		For the other models
reserve	*4.0 L (1.1/0.9 US/Imp gal)		
Engine oil type	SAE 10W/40, API SE or SF		
Engine oil capacity	Change	4 000 ml (4.2/3.5 US/Imp qt)	
	Filter change	4 200 ml (4.4/3.7 US/Imp qt)	
	Overhaul	5 100 ml (5.4/4.5 US/Imp qt)	
Front fork oil type	Fork oil LO 1		
Front fork oil capacity (each leg)	398 ml (13.5/14.0 US/Imp oz)		
Brake fluid type	DOT4		

Asterisk mark (\*) indicates the new M-model specifications.

## TIGHTENING TORQUE

## CHASSIS

ITEM	N·m	kg·m	lb·ft
Steering stem head nut	50 - 80	5.0 - 8.0	36.0 - 58.0
Front fork upper clamp bolt	22 - 35	2.2 - 3.5	16.0 - 25.5
Front fork lower clamp bolt	22 - 35	2.2 - 3.5	16.0 - 25.5
Front fork cap bolt	15 - 30	1.5 - 3.0	11.0 - 21.5
Front fork damper rod bolt	34 - 46	3.4 - 4.6	24.5 - 33.5
Front axle	85 - 115	8.5 - 11.5	61.5 - 83.0
Front axle pinch bolt	18 - 28	1.8 - 2.8	13.0 - 20.0
Handlebar holder mounting bolt	*10 - 16	*1.0 - 1.6	*7.0 - 11.5
Handlebar holder mounting nut	10 - 16	1.0 - 1.6	7.0 - 11.5
Front brake caliper mounting bolt	27 - 43	2.7 - 4.3	19.5 - 31.0
Front brake caliper housing bolt	20 - 25	2.0 - 2.5	14.5 - 18.0
Front brake pad mounting bolt	15 - 20	1.5 - 2.0	11.0 - 14.5
Front brake master cylinder bolt	5 - 8	0.5 - 0.8	3.5 - 6.0
Brake hose union bolt (Cylinder & Caliper)	15 - 20	1.5 - 2.0	11.0 - 14.5
Air bleeder valve (Front & Rear)	6 - 9	0.6 - 0.9	4.5 - 6.5
Front and rear disc bolt	15 - 25	1.5 - 2.5	11.0 - 18.0
Front footrest bracket mounting bolt	27 - 43	2.7 - 4.3	19.5 - 31.0
Swingarm pivot thrust adjuster lock nut	60 - 70	6.0 - 7.0	43.5 - 50.5
Swingarm pivot nut	85 - 115	8.5 - 11.5	61.5 - 83.0
Front footrest nut	35 - 55	3.5 - 5.5	25.5 - 40.0
Rear shock absorber mounting nut (Upper & Lower)	40 - 60	4.0 - 6.0	29.0 - 43.5
Rear cushion level/rod mounting nut	110 - 160	11.0 - 16.0	79.5 - 115.5
Rear brake caliper mounting bolt	18 - 28	1.8 - 2.8	13.0 - 20.0
Rear brake caliper housing bolt	30 - 36	3.0 - 3.6	21.5 - 26.0
Rear torque link nut (Front & Rear)	22 - 34	2.2 - 3.4	16.0 - 24.5
For E-03,28 and 33	18 - 28	1.8 - 2.8	13.0 - 20.0
Rear brake master cylinder mounting bolt	18 - 28	1.8 - 2.8	13.0 - 20.0
Rear brake rod lock nut	15 - 20	1.5 - 2.0	11.0 - 14.5
Rear axle nut	85 - 115	8.5 - 11.5	61.5 - 83.0
Rear sprocket nut	48 - 72	4.8 - 7.2	35.0 - 52.0

Asterisk mark (\*) indicates the new M-model specifications.

## EMISSION CONTROL CARBURETOR COMPONENTS

GSX-R1100 motorcycles are equipped with precision, manufactured carburetors for emission level control. These carburetors require special mixture control components and other precision adjustments to function properly.

There are several carburetor mixture control components in each carburetor assembly. Three (3) of these components are machined to much closer tolerances than standard machined carburetor jets. These three (3) particular jets — MAIN JET, NEEDLE JET, PILOT JET — must not be replaced by standard jets. To aid in identifying these three (3) jets a different design of letter and number are used. If replacement of these close tolerance jets becomes necessary, be sure to replace them with the same type close tolerance jets marked as in the examples shown below.

The jet needle is also of special manufacture. Only one clip position is provided on the jet needle. If replacement becomes necessary the jet needle may only be replaced with an equivalent performing replacement component. Suzuki recommends that Genuine Suzuki Parts be utilized whenever possible for the best possible performance and durability.

Conventional Figures Used on Standard Tolerance Jet Components	1 2 3 4 5 6 7 8 9 0
Emission Type Figures Used On Close Tolerance jet Components	1 2 3 4 5 6 7 8 9 0

The carburetor specifications for the emission-controlled GSX-R1100 are as follows.

Carburetor I.D. No.	Main Jet	Needle Jet	Jet Needle	Pilot Jet	Pilot Screw
41C2 (California model)	# 122.5	0-8	5D43	# 30	PRE-SET DO NOT ADJUST
41C1 (Other state models)			5D42		

The pilot screw is pre-set by the factory utilizing specialized testing and adjusting procedures. The pilot screw is not adjustable as the idle circuit is "sealed" after factory adjustment. Adjusting, interfering with, improper replacement, or resetting of any of the carburetor components may adversely affect carburetor performance and cause the motorcycle to exceed the exhaust emission level limits. If persons, who are unaware of these special carburetor servicing requirements tamper with the carburetors the Suzuki dealer should restore the carburetors to their original condition or if unable to effect repairs, contact the distributors representative for further technical information and assistance.



## ENGINE MOUNTING

CYLINDER HEAD

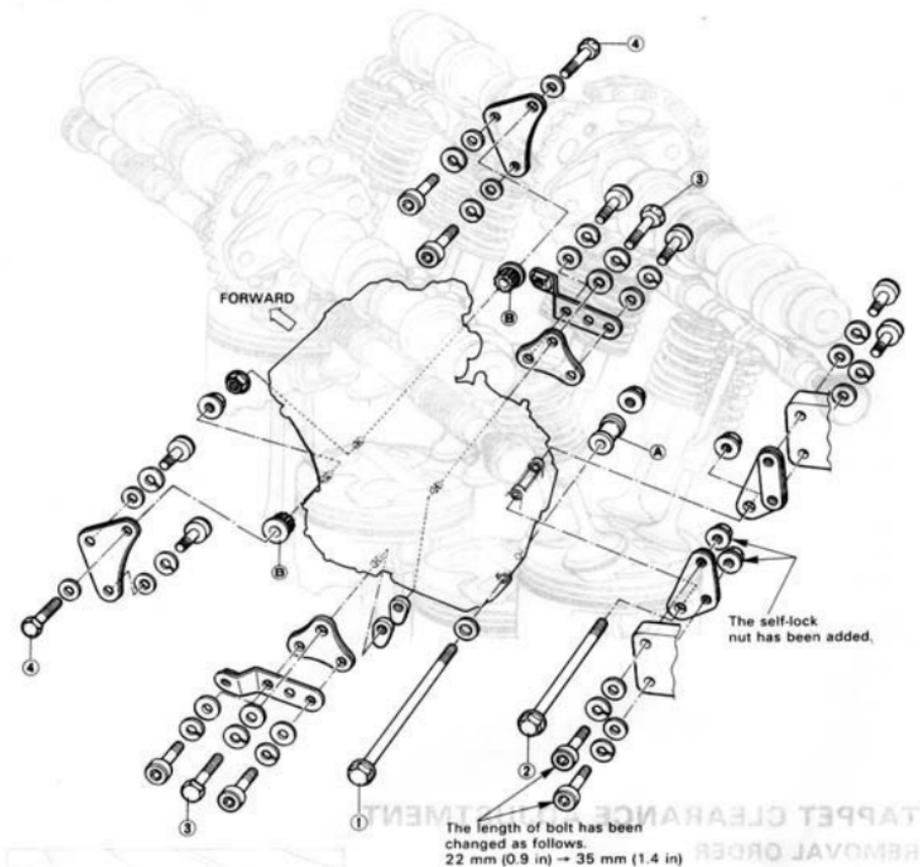

## TIGHTENING TORQUE

ITEM	N·m	kg·m	lb·ft
①, ②, ③	70-88	7.0-8.8	50.5-63.5
④	50-60	5.0-6.0	36.0-43.5
Other bolts	25-38	2.5-3.8	18.0-27.5

## CYLINDER HEAD

ENGINE MOUNTING

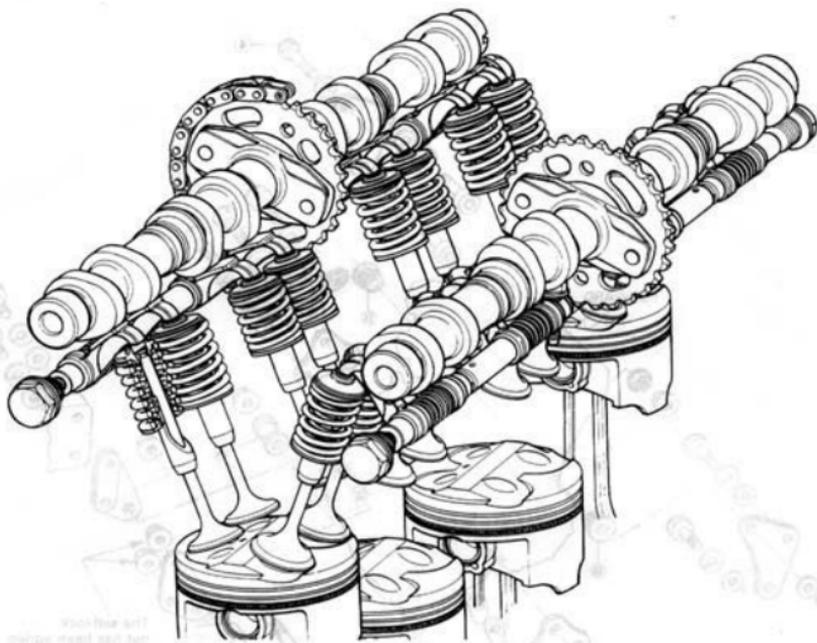

## TAPPET CLEARANCE ADJUSTMENT

## REMOVAL ORDER

- Seat
- Fairings
- Fuel tank
- Ignition coils
- Steering damper mounting bolt
- Air intake duct
- Breather cover
- Left and right oil hoses
- Cylinder head cover

Refer to Service manual (2 - 6 page).

## Tappet clearance

IN.: 0.10 - 0.20 mm (0.004 - 0.008 in)

EX.: 0.15 - 0.25 mm (0.006 - 0.010 in)

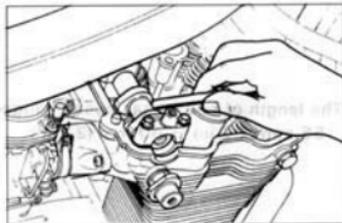

## TAPPET SHIM SELECTION TABLE [INTAKE]

TAPPET SHIM NO. (12892-41C00-XXX)

MEASURED TAPPET CLEARANCE (mm)	SUFFIX NO.		SPECIFIED CLEARANCE/NO ADJUSTMENT REQUIRED																				
	250	255	260	265	270	275	280	285	290	295	300	305	310	315	320	325	330	335	340	345	350		
0.10-0.20	2.60	2.65	2.70	2.75	2.80	2.85	2.90	2.95	3.00	3.05	3.10	3.15	3.2	3.25	3.3	3.35	3.4	3.45	3.5				
0.21-0.25	2.65	2.70	2.75	2.80	2.85	2.90	2.95	3.00	3.05	3.10	3.15	3.2	3.25	3.3	3.35	3.4	3.45	3.5					
0.26-0.30	2.65	2.70	2.75	2.80	2.85	2.90	2.95	3.00	3.05	3.10	3.15	3.2	3.25	3.3	3.35	3.4	3.45	3.5					
0.31-0.35	2.70	2.75	2.80	2.85	2.90	2.95	3.00	3.05	3.10	3.15	3.2	3.25	3.3	3.35	3.4	3.45	3.5						
0.36-0.40	2.75	2.80	2.85	2.90	2.95	3.00	3.05	3.10	3.15	3.2	3.25	3.3	3.35	3.4	3.45	3.5							
0.41-0.45	2.80	2.85	2.90	2.95	3.00	3.05	3.10	3.15	3.2	3.25	3.3	3.35	3.4	3.45	3.5								
0.46-0.50	2.85	2.90	2.95	3.00	3.05	3.10	3.15	3.2	3.25	3.3	3.35	3.4	3.45	3.5									
0.51-0.55	2.90	2.95	3.00	3.05	3.10	3.15	3.2	3.25	3.3	3.35	3.4	3.45	3.5										
0.56-0.60	2.95	3.00	3.05	3.10	3.15	3.2	3.25	3.3	3.35	3.4	3.45	3.5											
0.61-0.65	3.00	3.05	3.10	3.15	3.2	3.25	3.3	3.35	3.4	3.45	3.5												
0.66-0.70	3.05	3.10	3.15	3.2	3.25	3.3	3.35	3.4	3.45	3.5													
0.71-0.75	3.10	3.15	3.2	3.25	3.3	3.35	3.4	3.45	3.5														
0.76-0.80	3.15	3.2	3.25	3.3	3.35	3.4	3.45	3.5															
0.81-0.85	3.2	3.25	3.3	3.35	3.4	3.45	3.5																
0.86-0.90	3.25	3.3	3.35	3.4	3.45	3.5																	
0.91-0.95	3.3	3.35	3.4	3.45	3.5																		
0.96-1.00	3.35	3.4	3.45	3.5																			
1.01-1.05	3.4	3.45	3.5																				
1.06-1.10	3.45	3.5																					
1.11-1.15	3.5																						

## HOW TO USE THIS CHART:

- Measure tappet clearance. "ENGINE IS COLD"
- Measure present shim size.
- Match clearance in vertical column with present shim size in horizontal column.

## EXAMPLE

Tappet clearance is 0.23 mm  
 Present shim size 2.70 mm  
 Shim size to be used 2.80 mm



## FRONT FORK (INVERTED TELESCOPIC TYPE)

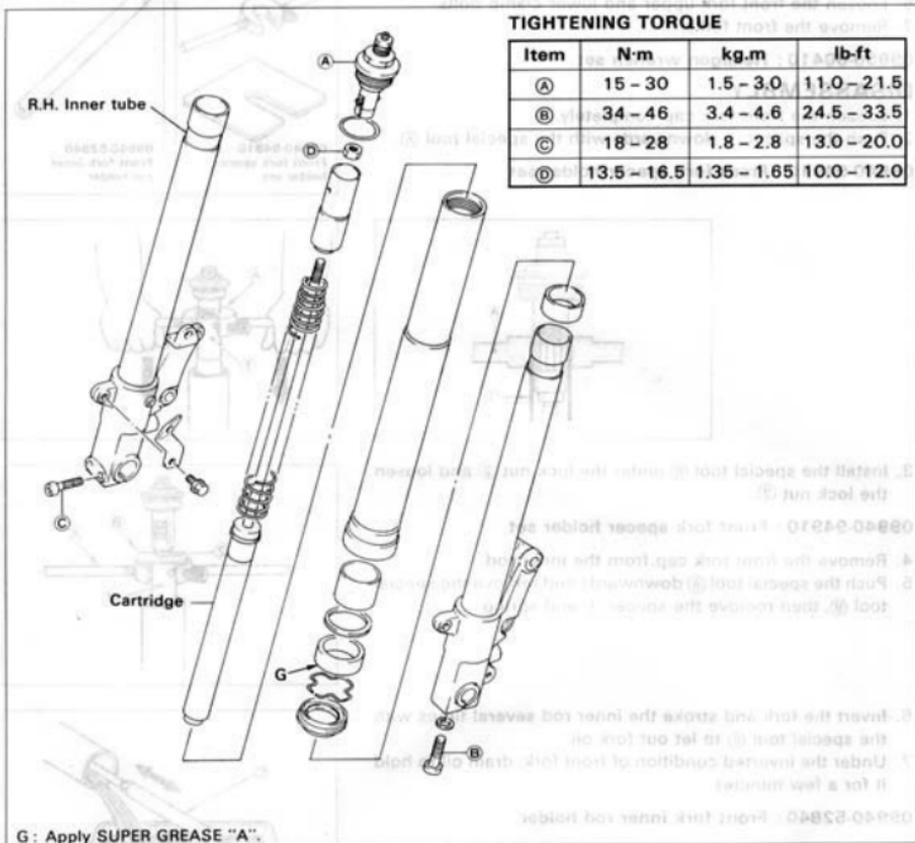

## REMOVAL

1. Remove the lower fairing assembly.
2. Support the motorcycle with a jack or wooden block.
3. Remove the front wheel.
4. Remove the front fender.

09900-00401: L-type hexagon wrench

## NOTE:

Slightly loosen the front fork cap to facilitate later disassembly before loosening the front fork clamp bolts. When removing the left front fork make sure to loosen the steering damper bracket bolt ①.

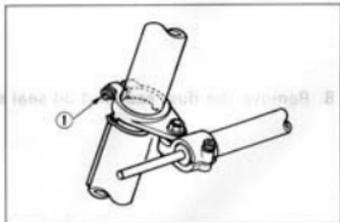

- Loosen the handlebar holder mounting bolts and nuts.
- Loosen the front fork upper and lower clamp bolts.
- Remove the front forks.

#### 09900-00410 : Hexagon wrench set

### DISASSEMBLY

- Loosen the front fork cap completely.
- Push the spacer ① downwards with the special tool ④.

#### 09940-94910 : Front fork spacer holder set

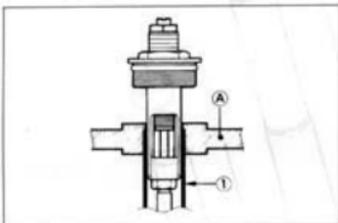

- Install the special tool ⑤ under the lock nut ② and loosen the lock nut ②.

#### 09940-94910 : Front fork spacer holder set

- Remove the front fork cap from the inner rod.
- Push the special tool ④ downwards and remove the special tool ⑤, then remove the spacer ① and spring.

### NEW SPECIAL TOOLS



09940-94910  
Front fork spacer  
holder set

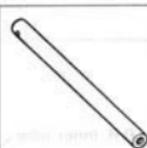

09940-52840  
Front fork inner  
rod holder

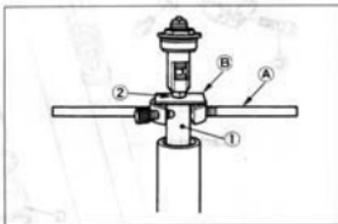
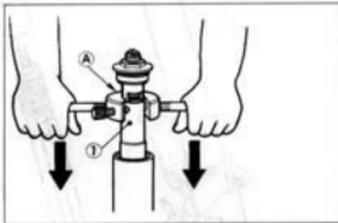

- Invert the fork and stroke the inner rod several times with the special tool ③ to let out fork oil.
- Under the inverted condition of front fork, drain oil to hold it for a few minutes.

#### 09940-52840 : Front fork inner rod holder

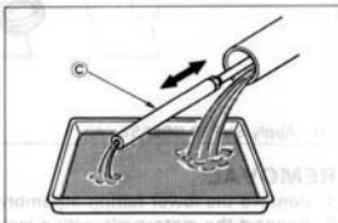

- Remove the dust seal and oil seal stopper ring.

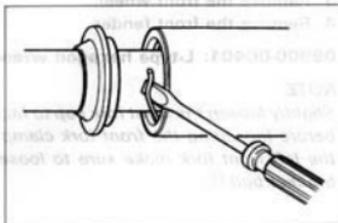

9. Separate the outer tube from the inner tube.

**NOTE:**

*Be careful not to damage the inner tube.*

**CAUTION:**

The outer tube and inner tube "ANTI-FRICTION" metals must be replaced along with the oil seal and dust seal, when assembling the front fork.

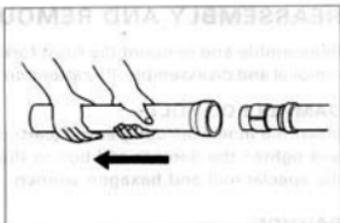

10. While holding the caliper mounting portion ① by vise and remove the damper rod bolt with the special tool and hexagon wrench.

09940-54821 : Front fork disassembling tool

09940-54830 : Attachment

09900-00401 : "L" type hexagon wrench set

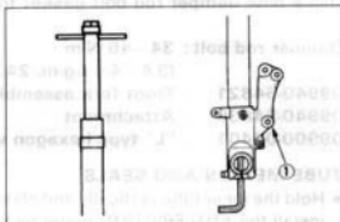

11. Remove the inner rod/damper rod (cartridge) out of the inner tube.

**CAUTION:**

Do not attempt to disassemble the inner rod/damper rod.

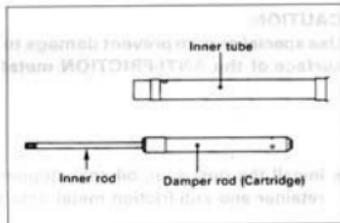

## INSPECTION

### INNER AND OUTER TUBE

Inspect the inner tube sliding surface and outer tube sliding surface for any scuffing.

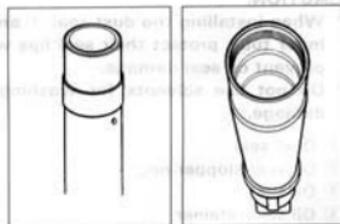

### FORK SPRING

Measure the fork spring free length. If it is shorter than the service limit, replace it with a new one.

**Service limit : 277 mm (10.9 in)**

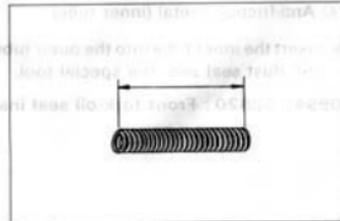

## REASSEMBLY AND REMOUNTING

Reassemble and remount the front fork in the reverse order of removal and disassembly. Pay attention to the following points:

### DAMPER ROD BOLT

Insert the inner rod/damper rod (cartridge) into the inner tube and tighten the damper rod bolt to the specified torque with the special tool and hexagon wrench.

#### CAUTION:

Use a new damper rod bolt gasket to prevent oil leakage.

Damper rod bolt : 34 – 46 N·m  
(3.4 – 4.6 kg·m, 24.5 – 33.5 lb·ft)

09940-54821 : Front fork assembling tool

09940-54830 : Attachment

09900-00401 : "L" type hexagon wrench set

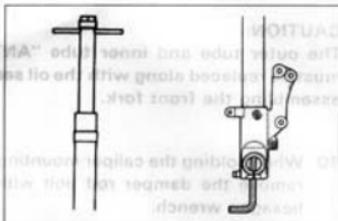

### TUBE METALS AND SEALS

● Hold the inner tube vertically and clean the metal groove and install the ANTI-FRICTION metal by hand as shown.

#### CAUTION:

Use special care to prevent damage to the "TEFLON" coated surface of the ANTI-FRICTION metal when mounting it.

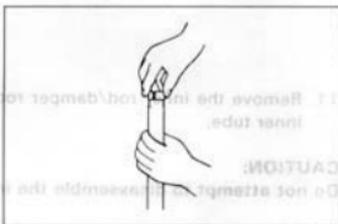

● Install the dust seal, oil seal stopper ring, oil seal, oil seal retainer and anti-friction metal onto the inner tube.

#### CAUTION:

● When installing the dust seal ① and oil seal ③ onto the inner tube, protect their seal lips with a vinyl film A to prevent oil seal damage.

● Do not use solvents for washing to prevent oil seal damage.

- ① Dust seal
- ② Oil seal stopper ring
- ③ Oil seal
- ④ Oil seal retainer
- ⑤ Anti-friction metal (outer tube)
- ⑥ Anti-friction metal (inner tube)

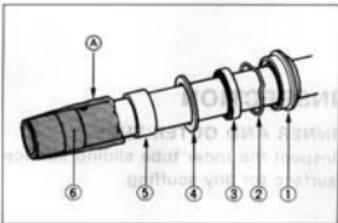

● Insert the inner tube into the outer tube and install the oil seal and dust seal with the special tool.

09940-52820 : Front fork oil seal installer

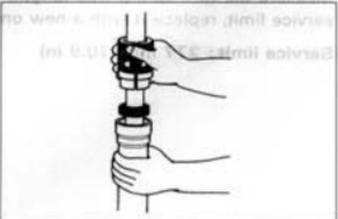



**FORK OIL**

- Place the front fork vertically with fully compressed and without spring.
- Pour specified front fork oil up to the top level of the outer tube.

99000-99044-L01 : Fork oil L01

- Move the inner rod slowly with the special tool more than ten times until bubbles do not come out from oil.

09940-52840 : Front fork inner rod holder

**NOTE:**

*Pour front fork oil up to the top of the outer tube to find bubbles while bleeding air.*

- Pour specified front fork oil up to the top level of the outer tube again.
- Fully stroke the outer tube to pump out air from outer tube.
- Keep the front fork vertically and wait 5 – 6 minutes.

**NOTE:**

- \* Always keep oil level over cartridge top surface, or air may enter cartridge when stroking.
- \* Take extreme attention to pump out air completely.

- Hold the front fork vertical and adjust fork oil level with the special tool.

**NOTE:**

*When adjusting fork oil level, remove the fork spring and compress the outer tube fully.*

09943-74111 : Fork oil level gauge

Fork oil level : 131 mm (5.16 in)

Fork oil capacity : 398 ml (13.5/14.0 US/lmp oz)  
(each leg)

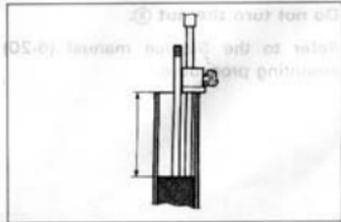
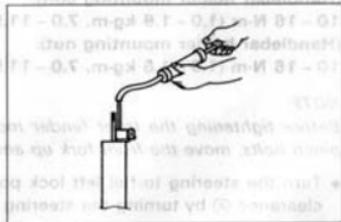
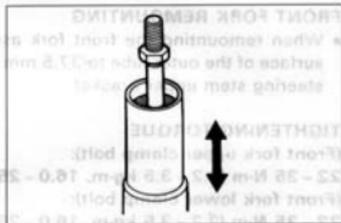
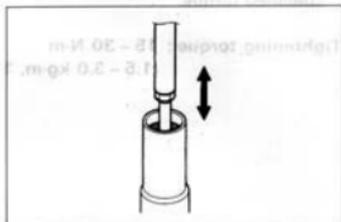
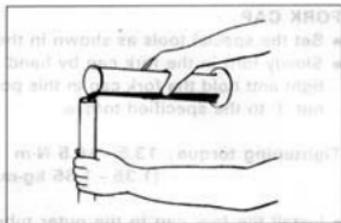

**FORK CAP**

- Set the special tools as shown in the illustration.
- Slowly turn in the fork cap by hand until it stops by finger tight and hold the fork cap in this position, tighten the lock nut ① to the specified torque.

**Tightening torque: 13.5 – 16.5 N·m**

**(1.35 – 1.65 kg·m, 10.0 – 12.0 lb·ft)**

- Install the fork cap to the outer tube and tighten it to the specified torque.

**Tightening torque: 15 – 30 N·m**

**(1.5 – 3.0 kg·m, 11.0 – 21.5 lb·ft)**

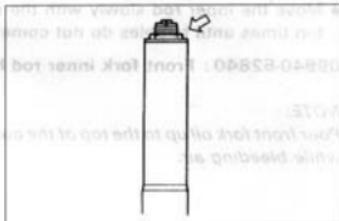
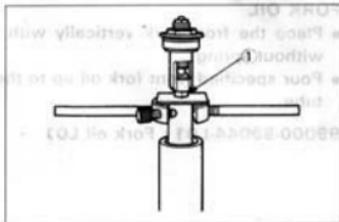
**FRONT FORK REMOUNTING**

- When remounting the front fork assembly, set the upper surface of the outer tube to 37.5 mm height from that of the steering stem upper bracket.

**TIGHTENING TORQUE**

**(Front fork upper clamp bolt):**

**22 – 35 N·m (2.2 – 3.5 kg·m, 16.0 – 25.5 lb·ft)**

**(Front fork lower clamp bolt):**

**22 – 35 N·m (2.2 – 3.5 kg·m, 16.0 – 25.5 lb·ft)**

**(Handlebar holder mounting bolt):**

**10 – 16 N·m (1.0 – 1.6 kg·m, 7.0 – 11.5 lb·ft)**

**(Handlebar holder mounting nut):**

**10 – 16 N·m (1.0 – 1.6 kg·m, 7.0 – 11.5 lb·ft)**

**NOTE:**

*Before tightening the front fender mounting bolts and axle pinch bolts, move the front fork up and down 4 or 5 times.*

- Turn the steering to full left lock position to obtain 4 mm clearance  $\text{\textcircled{A}}$  by turning the steering damper bracket.

**CAUTION:**

**Do not turn the nut  $\text{\textcircled{B}}$ .**

Refer to the Service manual (6-20) for steering damper mounting procedure.

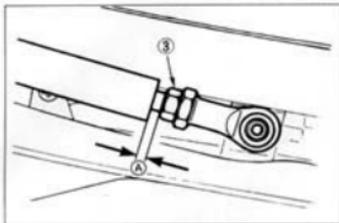
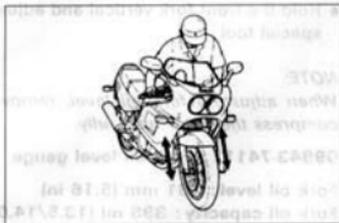
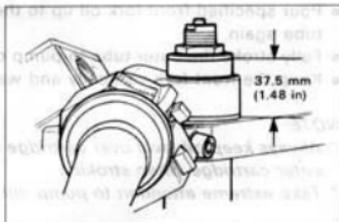

## STEERING

SUSPENSION SETTING (For E-03, 28 and 33 models)

FRONT SUSPENSION SETTING TABLE

Item	Setting	Spring Pre-load	Damping force
1	1	1	1
2	2	2	2
3	3	3	3
4	4	4	4

REAR SUSPENSION SETTING TABLE

Item	Setting	Spring Pre-load	Damping force
1	1	1	1
2	2	2	2
3	3	3	3
4	4	4	4
5	5	5	5
6	6	6	6
7	7	7	7
8	8	8	8
9	9	9	9
10	10	10	10
11	11	11	11
12	12	12	12
13	13	13	13
14	14	14	14
15	15	15	15
16	16	16	16
17	17	17	17
18	18	18	18
19	19	19	19
20	20	20	20
21	21	21	21
22	22	22	22
23	23	23	23
24	24	24	24
25	25	25	25
26	26	26	26
27	27	27	27
28	28	28	28
29	29	29	29
30	30	30	30
31	31	31	31
32	32	32	32
33	33	33	33
34	34	34	34
35	35	35	35
36	36	36	36
37	37	37	37
38	38	38	38
39	39	39	39
40	40	40	40
41	41	41	41
42	42	42	42
43	43	43	43
44	44	44	44
45	45	45	45
46	46	46	46
47	47	47	47
48	48	48	48
49	49	49	49
50	50	50	50
51	51	51	51
52	52	52	52
53	53	53	53
54	54	54	54
55	55	55	55
56	56	56	56
57	57	57	57
58	58	58	58
59	59	59	59
60	60	60	60
61	61	61	61
62	62	62	62
63	63	63	63
64	64	64	64
65	65	65	65
66	66	66	66
67	67	67	67
68	68	68	68
69	69	69	69
70	70	70	70
71	71	71	71
72	72	72	72
73	73	73	73
74	74	74	74
75	75	75	75
76	76	76	76
77	77	77	77
78	78	78	78
79	79	79	79
80	80	80	80
81	81	81	81
82	82	82	82
83	83	83	83
84	84	84	84
85	85	85	85
86	86	86	86
87	87	87	87
88	88	88	88
89	89	89	89
90	90	90	90
91	91	91	91
92	92	92	92
93	93	93	93
94	94	94	94
95	95	95	95
96	96	96	96
97	97	97	97
98	98	98	98
99	99	99	99
100	100	100	100

## TIGHTENING TORQUE

ITEM	N·m	kg·m	lb·ft
A	50 - 80	5.0 - 8.0	36.0 - 58.0
B	22 - 35	2.2 - 3.5	16.0 - 25.5
C	40 - 50	4.0 - 5.0	29.0 - 36.0
D	22 - 35	2.2 - 3.5	16.0 - 25.5
E, F, G	10 - 16	1.0 - 1.6	7.0 - 11.5

G: Apply SUZUKI SUPER GREASE "A".



# SUSPENSION SETTING (For the Other models)

## FRONT SUSPENSION SETTING TABLE

Item		Spring Pre-load	Damping force	
			Compression	Rebound
Solo riding	Softer	5	5	4
	Standard	4	4	3
	Stiffer	3	3	2
Dual riding		4	4	3

## REAR SUSPENSION SETTING TABLE

Item		Spring Pre-load	Damping force	
			Compression	Rebound
Solo riding	Softer	3	STD setting position + 1 click	STD setting position + 1 click
	Standard	4	STD setting position is stamped on shock absorber body	STD setting position is stamped on shock absorber body
	Stiffer	5	STD setting position - 1 click	STD setting position - 1 click
Dual riding		4	Same as STD setting	Same as STD setting

### NOTE:

- The rear suspension STD setting position is stamped on the shock absorber body.
- The STD setting position varies a little from each GSX-R1100 motorcycle.
- Fully turn the damping force adjuster clockwise it is at 0 position and turn out it to each STD setting position .

"R" is Rebound. "C" is Compression.

- (A): Spring adjuster  
 (B): Compression adjuster  
 (C): Rebound adjuster

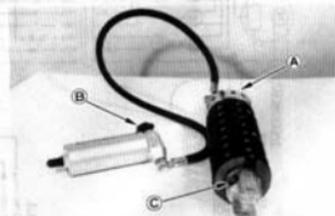
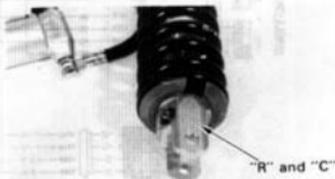

## WIRING DIAGRAM

FOR U.S.A. MODEL

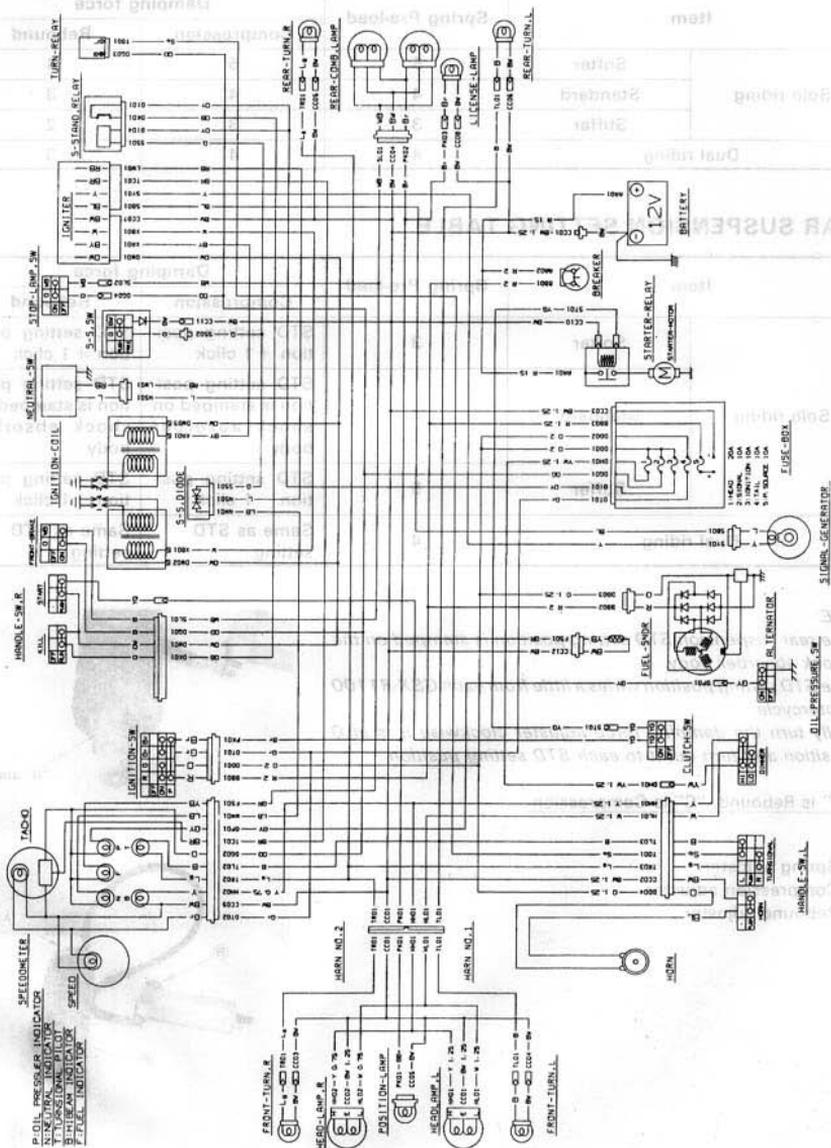

# FOR GENERAL, ENGLAND, AND AUSTRALIA MODELS

FOR CANADA MODEL

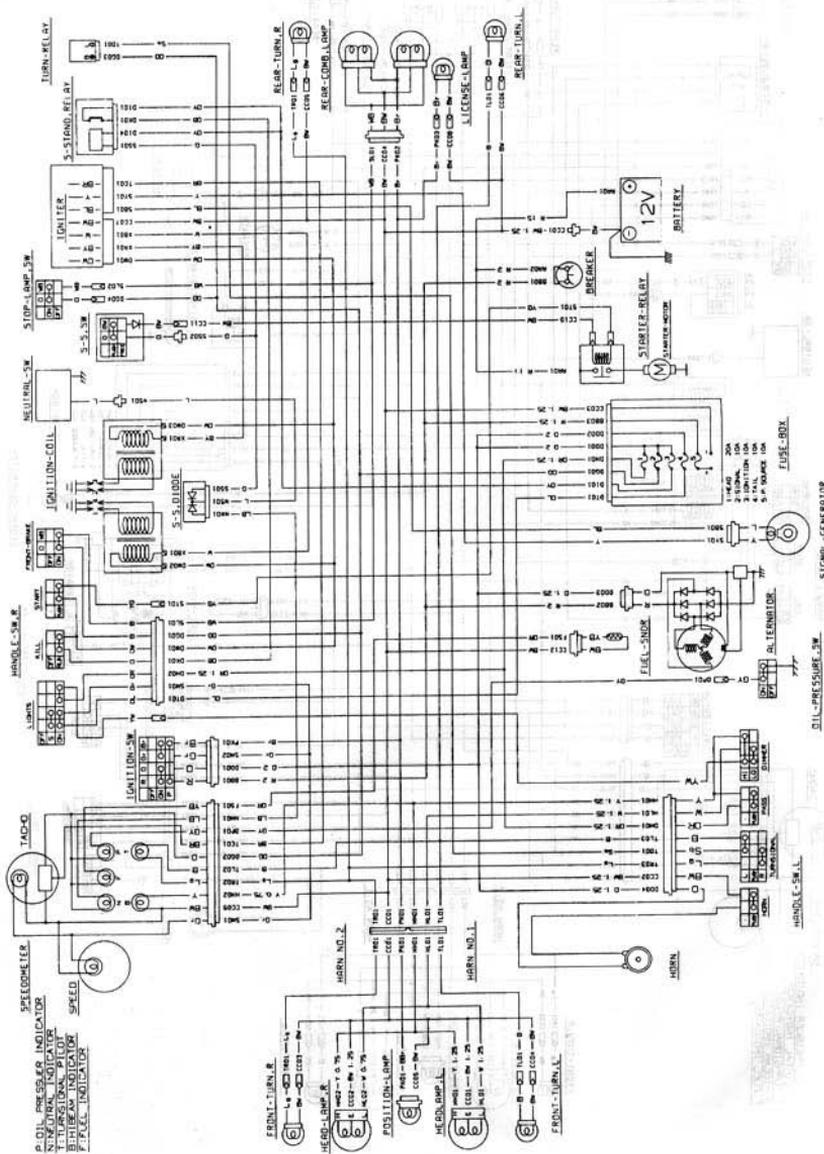

## FOR CANADA MODEL

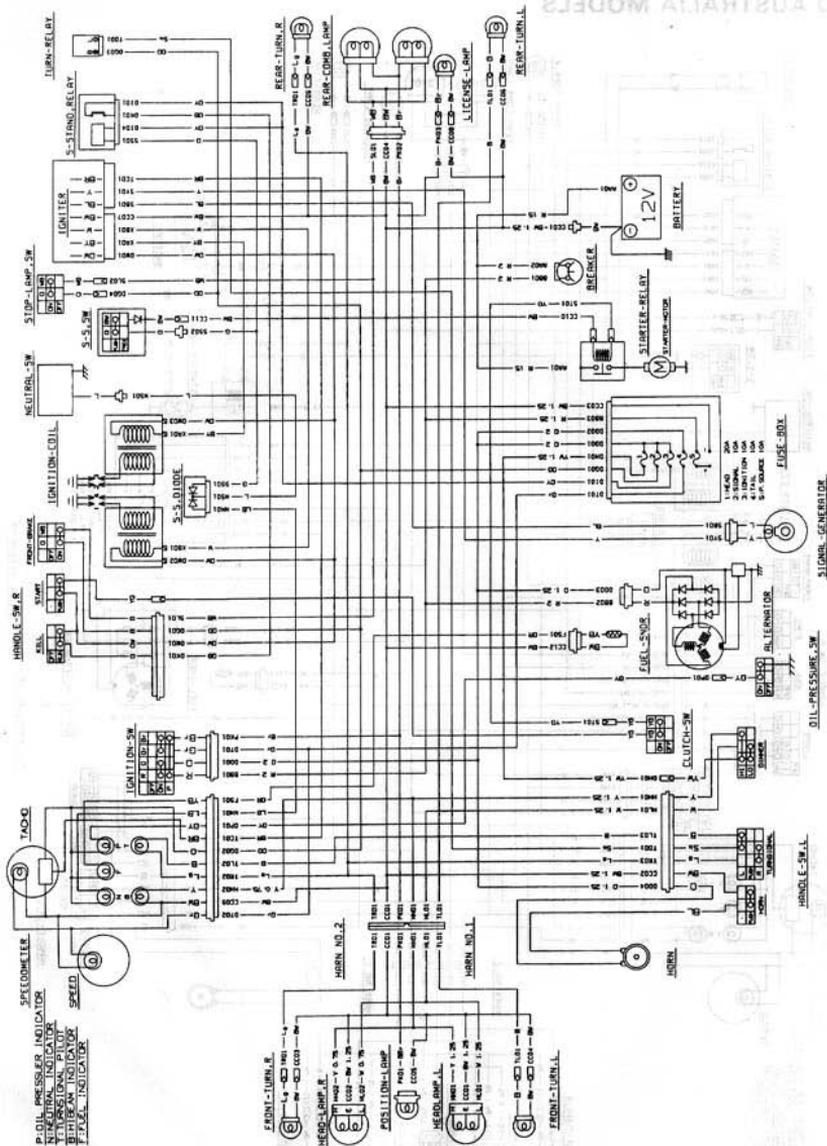
FOR GENERAL ENGLAND  
AND AUSTRALIA MODELS













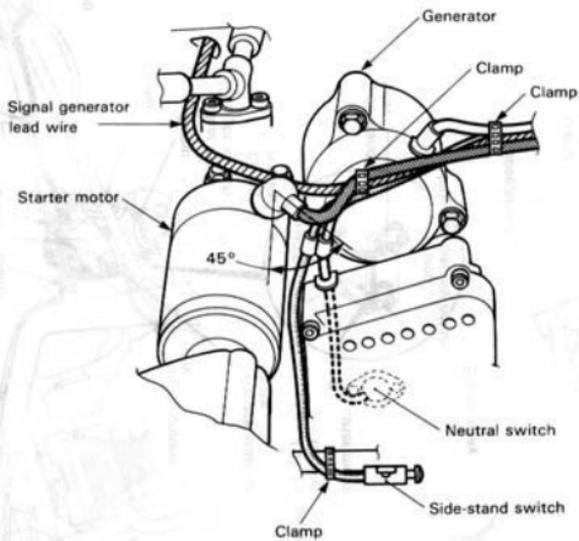

# FUEL HOSE AND FUEL TANK WATER DRAIN HOSE ROUTING

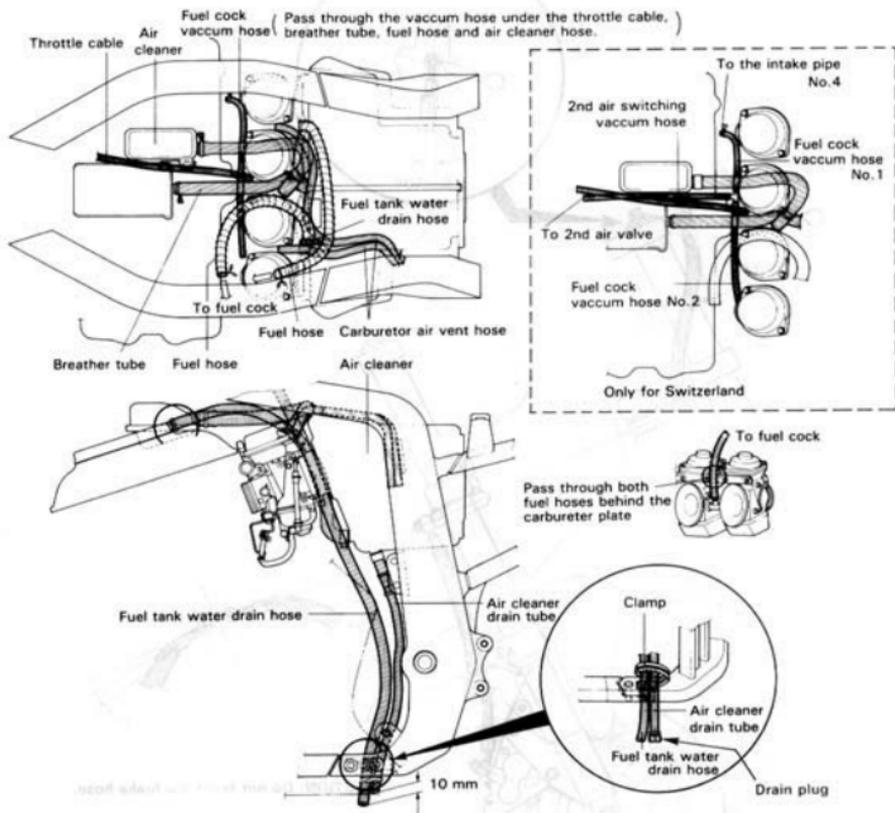

**NOTE:**

When you clean the air element, drain water from the air cleaner drain tube end by removing the drain plug.

# FRONT BRAKE HOSE ROUTING

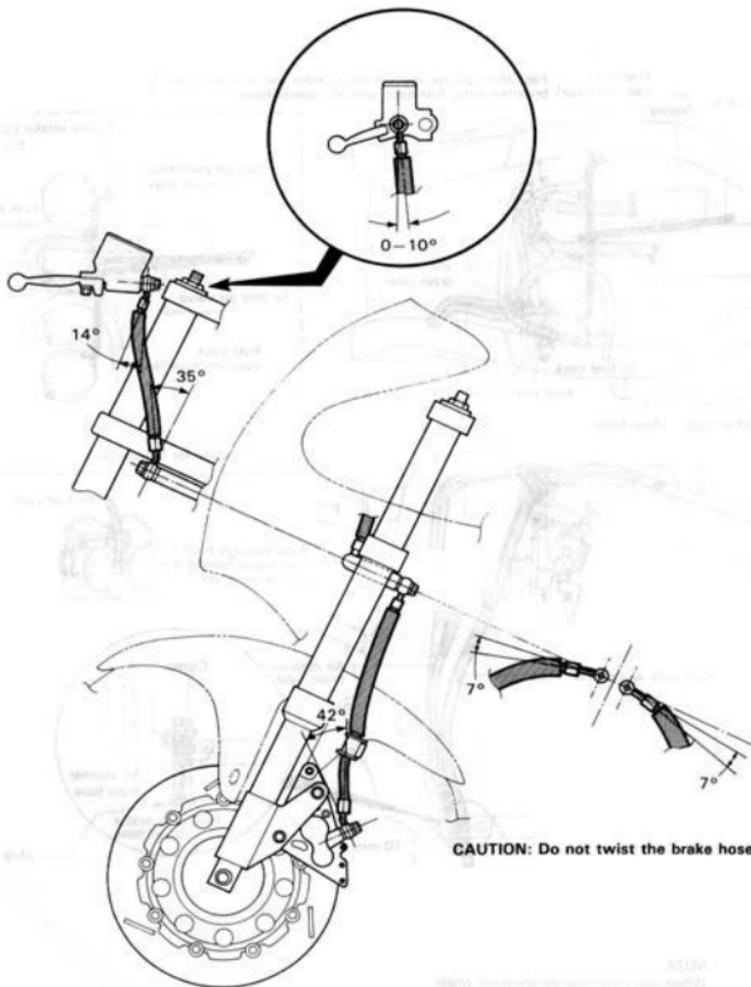

STOP  
DO NOT PROCEED TO THE NEXT STEP UNTIL YOU HAVE  
READ THE ENTIRE MANUAL AND UNDERSTAND THE  
SAFETY INFORMATION.



## REAR BRAKE HOSE ROUTING

CLUTCH HOSE ROUTING

FOR U.S. &amp; AUSTRIA MODELS

CAUTION: Do not twist the brake hose.

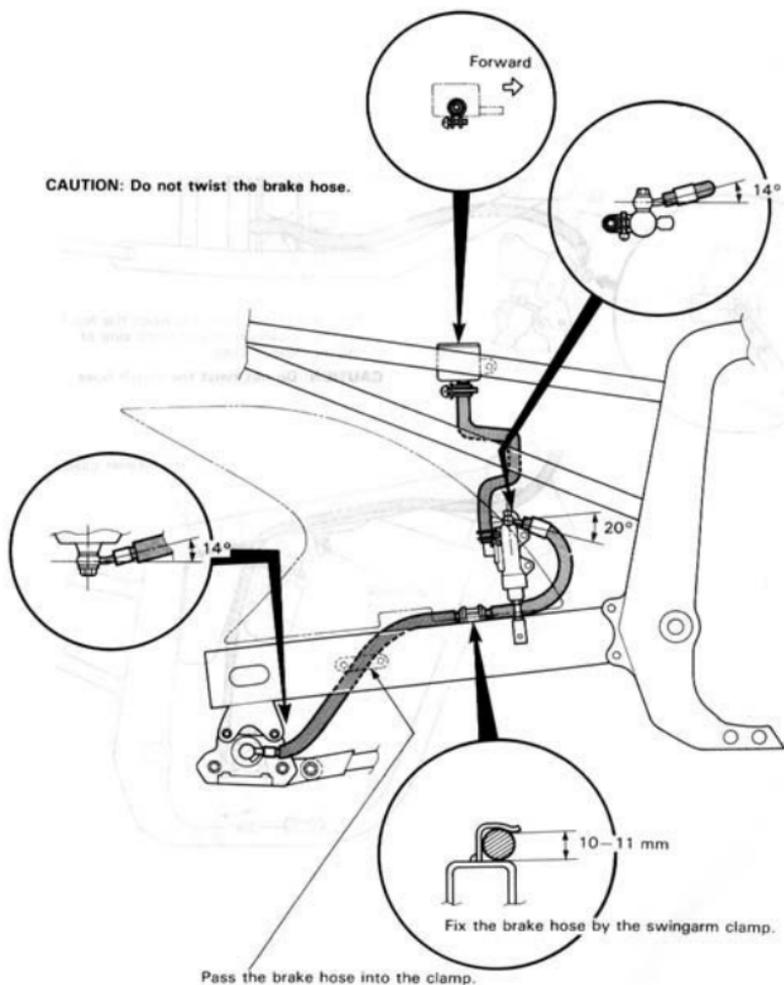

# CLUTCH HOSE ROUTING

REAR BRAKE HOSE ROUTING

FOR U.S.A., SWITZERLAND AND AUSTRIA MODELS

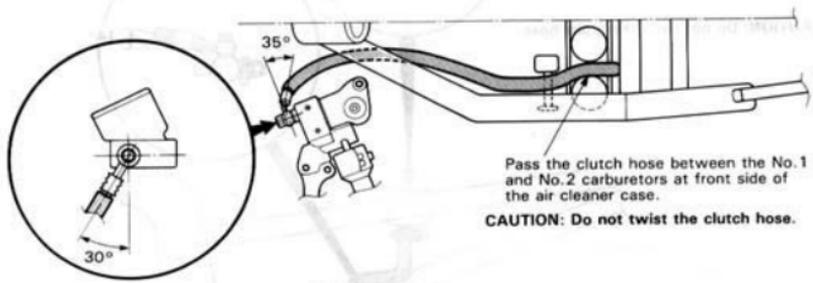

Pass the clutch hose between the No. 1 and No. 2 carburetors at front side of the air cleaner case.

**CAUTION:** Do not twist the clutch hose.

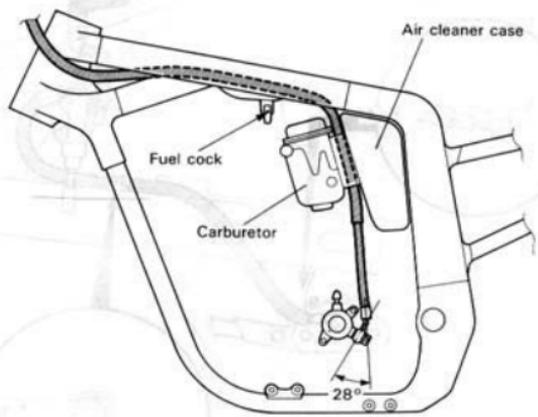

## FOR THE OTHER MODELS

CABLE ROUTING

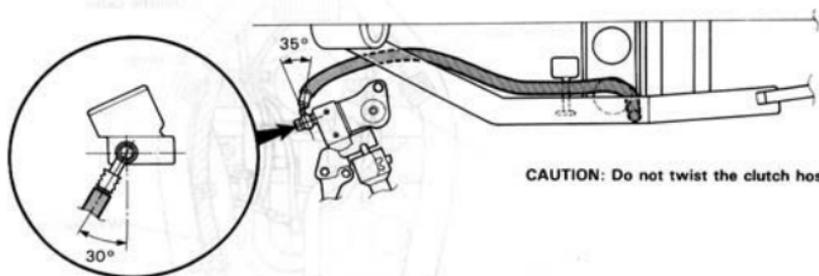
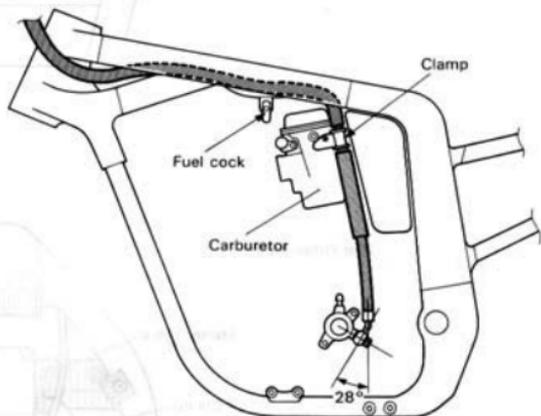
**CAUTION:** Do not twist the clutch hose.

## CABLE ROUTING

FOR THE OTHER MODELS

(For California, Switzerland  
and Austria models)

Starter cable

2nd air cleaner

Throttle cable

Clamp

Clamp

Clamp

Wire harness

(For Other models)

Starter cable

Throttle cable

Breather cover

Clamp

Clamp

Wire harness

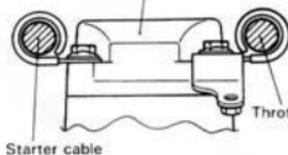

Starter cable

Throttle cable

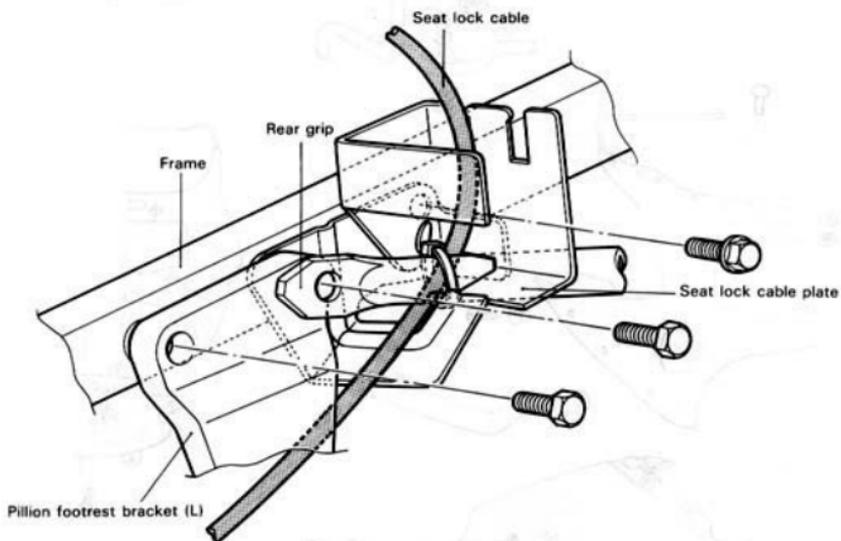

## FAIRING INSTALLATION

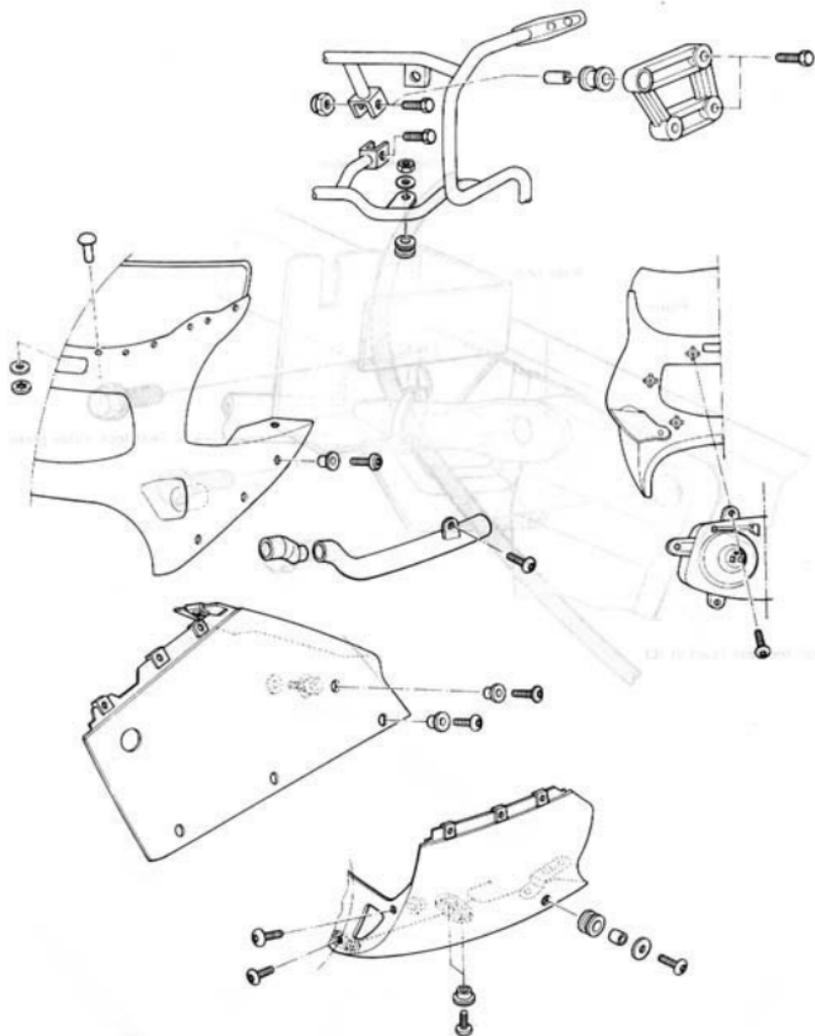

## FRAME COVER INSTALLATION

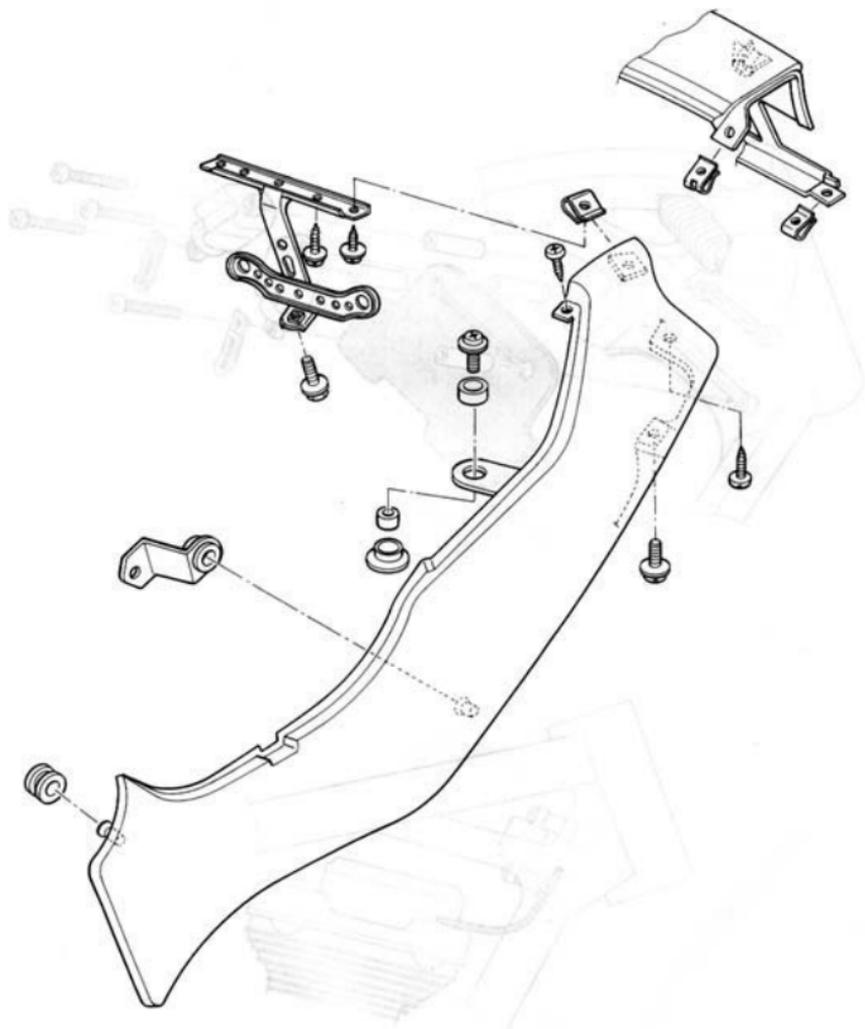

ENGINE HEAT PROTECTOR FRAME COVER INSTALLATION

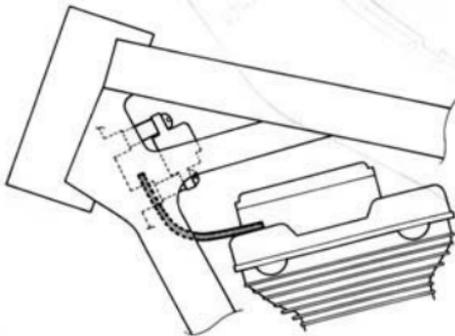
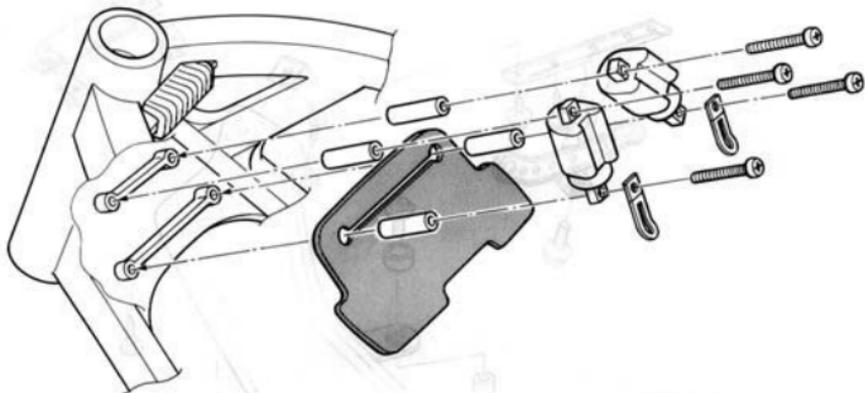



# AIR SUPPLY SYSTEM

FOR CALIFORNIA, SWITZERLAND AND AUSTRIA MODELS

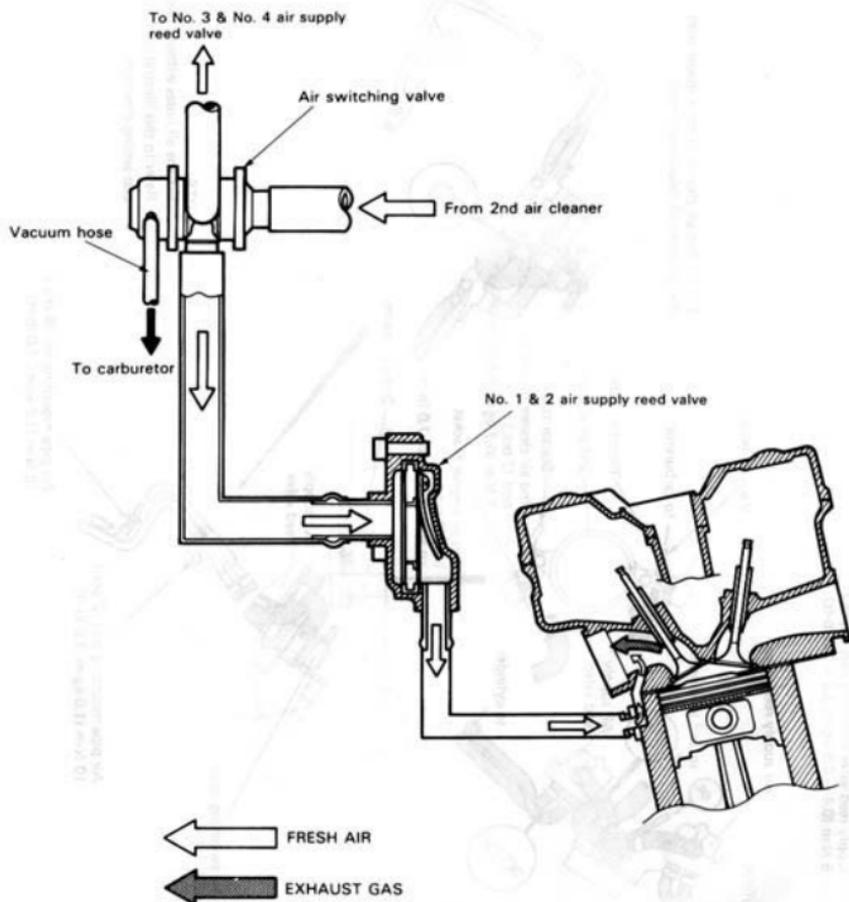

## AIR SUPPLY HOSE ROUTING

FOR CALIFORNIA, SWITZERLAND AND AUSTRIA MODELS

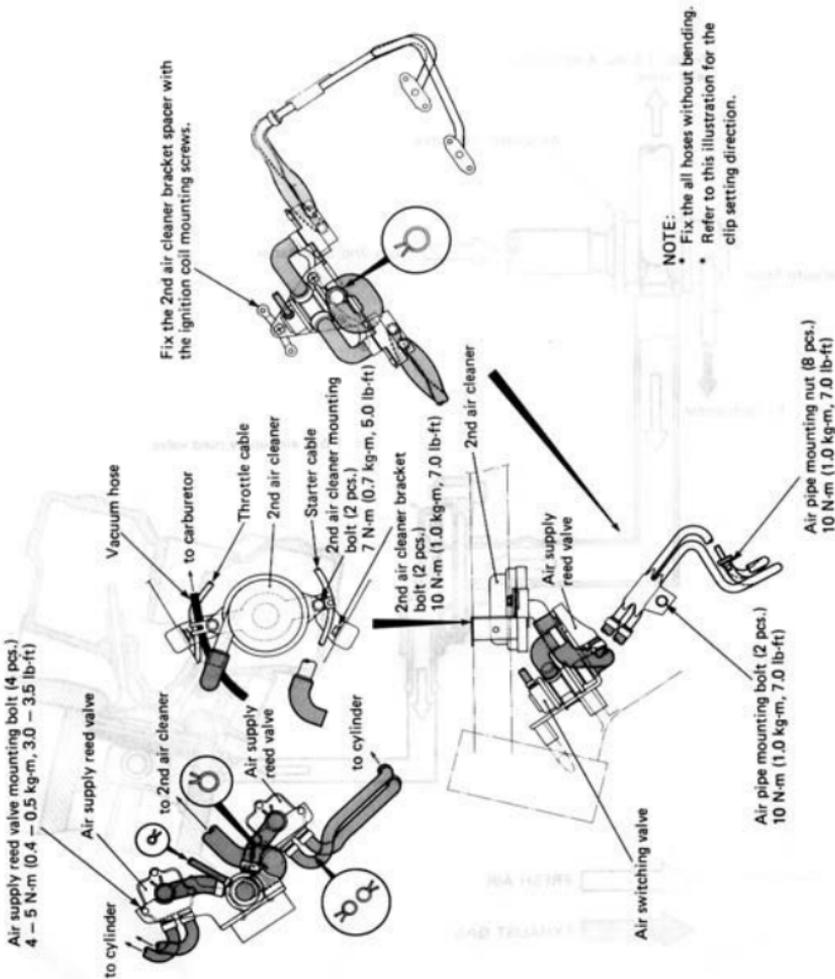

## HIGH TENSION CORD ROUTING

FOR CALIFORNIA, SWITZERLAND AND AUSTRIA MODELS

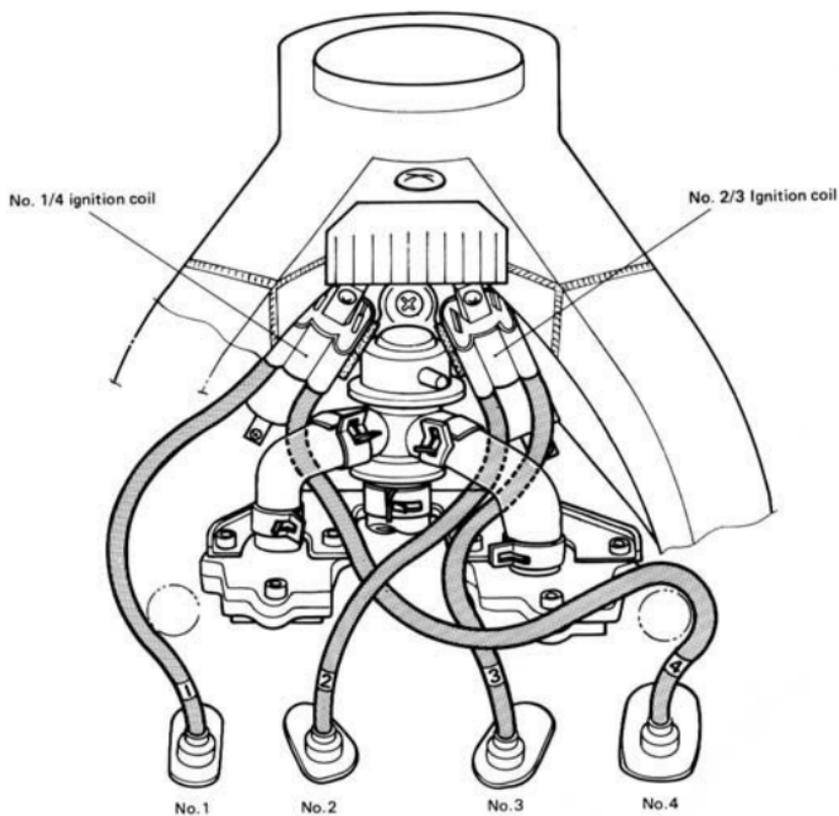



## SPECIFICATIONS

### DIMENSIONS AND DRY MASS

Overall length.....	2135 mm (84.1 in) .....	For E-15, 17 models
	2215 mm (87.2 in) .....	For E-16, 18, 22 models
	2085 mm (82.1 in) .....	For the other models
Overall width.....	755 mm (29.7 in)	
Overall height.....	1150 mm (45.3 in)	
Wheelbase.....	1465 mm (57.7 in)	
Ground clearance.....	115 mm (4.5 in)	
Dry mass.....	228 kg (503 lbs) .....	For E-33 model
	227 kg (500 lbs) .....	For E-18, 39 models
	226 kg (498 lbs) .....	For the other models

### ENGINE

Type.....	Four-stroke, Air-cooled with SACS, DOHC, TSCC
Number of cylinders.....	4
Bore.....	78.0 mm (3.07 in)
Stroke.....	59.0 mm (2.32 in)
Piston displacement.....	1127cm <sup>3</sup> (68.8 cu.in)
Carburetor.....	MIKUNI BST36SS, four .....
	39 models
	MIKUNI BST40SS, four ...
	For the other models
Air cleaner.....	Non-woven fabric element
Starter system.....	Starter motor
Lubrication system.....	Wet sump

### TRANSMISSION

Clutch.....	Wet multi-plate type, hydraulically operated
Transmission.....	5-speed constant mesh
Gearshift pattern.....	1-down, 4-up
Primary reduction.....	1.565 (72/46)
Final reduction.....	3.200 (48/15)
Gear ratios, Low.....	2.384 (31/13)
2nd.....	1.631 (31/19)
3rd.....	1.250 (25/20)
4th.....	1.045 (23/22)
Top.....	0.913 (21/23)
Drive chain.....	TAKASAGO RK532GSV2, 118 links

## CHASSIS

Front suspension.....	Inverted telescopic, coil spring, oil damped, inner rod type, spring pre-load fully adjustable, damping force compression 8-way and rebound 10-way adjustable.
Rear suspension.....	Link type system, gas/oil damped, coil spring, spring pre-load 7-way adjustable, damping force compression 17-way and rebound 19-way adjustable
Steering angle.....	30° (right & left)
Caster.....	66°
Trail.....	92 mm (3.6in)
Turning radius.....	3.2 m (10.5ft)
Front brake.....	Disc brake, twin
Rear brake.....	Disc brake
Front tire size.....	120/70ZR17
Front tire size.....	180/55ZR17
Front fork stroke.....	120mm (4.7in)
Rear wheel travel.....	158mm (6.2in)

## ELECTRICAL

Ignition type.....	Fully Transistorized
Ignition timing.....	7° B.T.D.C. at 1500 r/min..... For E-33 model 13° B.T.D.C. at 1500 r/min..... For the other models
Spark plug.....	N.G.K.: JR9B
Battery.....	12V 50.4 kC (14Ah)/10HR
Generator.....	Three-phase A.C. Generator
Fuse.....	10/10/10/10/10A ..... For E-34 model 20/10/10/10/10A ..... For the other models
Circuit breaker.....	30A

## CAPACITIES

Fuel tank, including reserve.....	20.0 L (5.3/4.4 US/Imp gal) ..... For E-18, 39 models 18.5 L (4.8/4.1 US/Imp gal) ..... For E-33 model 22.0 L (5.8/4.8 US/Imp gal) ..... For the other models
Engine oil, Oil change with oil filter change.....	4.2 L (4.4/3.7 US/Imp qt)
Front fork oil.....	398 ml (13.5/14.0 US/Imp oz)

These specifications are subject to change without notice.

E-39: Austria
E-34: Italy
E-33: California (U.S.A.) model
E-03: U.S.A. model
E-17: Sweden model
E-18: Switzerland model

## SERVICE DATA

## VALVE + GUIDE

Unit: mm (in)

ITEM	STANDARD		LIMIT
Valve diam.	IN.	28.5 (1.12)	—
	EX.	25 (1.0)	—
Valve lift	IN.	8.8 (0.35)	—
	EX.	8.2 (0.32)	—
Valve clearance (when cold)	IN.	0.10 - 0.20 (0.004 - 0.008)	—
	EX.	0.15 - 0.25 (0.006 - 0.010)	—
Valve guide to valve stem clearance	IN.	0.020 - 0.047 (0.0008 - 0.0019)	0.35 (0.014)
	EX.	0.040 - 0.067 (0.0016 - 0.0026)	0.35 (0.014)
Valve guide I.D.	IN. & EX.	5.000 - 5.012 (0.1969 - 0.1973)	—
Valve stem O.D.	IN.	4.965 - 4.980 (0.1955 - 0.1961)	—
	EX.	4.945 - 4.960 (0.1947 - 0.1953)	—
Valve stem runout	IN. & EX.	—	0.05 (0.002)
Valve head thickness	IN. & EX.	—	0.5 (0.02)
Valve seat width	IN. & EX.	0.9 - 1.1 (0.035 - 0.043)	—
Valve head radial runout	IN. & EX.	—	0.03 (0.001)
Valve spring free length (IN. & EX.)	INNER	—	39.4 (1.55)
	OUTER	—	41.8 (1.65)
Valve spring tension (IN. & EX.)	INNER	5.3 - 6.5 kg (11.7 - 14.3 lbs) at length 31 mm (1.2 in)	—
	OUTER	13.1 - 15.1 kg (28.9 - 33.3 lbs) at length 34.5 mm (1.4 in)	—

## CAMSHAFT + CYLINDER HEAD

Unit: mm (in)

ITEM		STANDARD	LIMIT	
Cam height	E-01, 03, 28, 33, 34	IN.	33.922 – 33.978 (1.3355 – 1.3377)	33.630 (1.3240)
			Others	33.892 – 33.948 (1.3343 – 1.3365)
	E-01, 03, 28, 33, 34	EX.	33.632 – 33.688 (1.3241 – 1.3263)	33.340 (1.3126)
			Others	33.612 – 33.668 (1.3233 – 1.3255)
Camshaft journal oil clearance		IN. & EX.	0.032 – 0.066 (0.0013 – 0.0026)	0.150 (0.0059)
Camshaft journal holder I.D.		IN. & EX.	22.012 – 22.025 (0.8666 – 0.8671)	—
Camshaft journal O.D.		IN. & EX.	21.959 – 21.980 (0.8645 – 0.8654)	—
Camshaft runout		IN. & EX.	—	0.10 (0.004)
Cam chain 20-pitch length		—	—	158.0 (6.22)
Cam chain pin (at arrow "3")		22nd pin		—
Rocker arm I.D.		IN. & EX.	12.000 – 12.018 (0.4724 – 0.4731)	—
Rocker arm shaft O.D.		IN. & EX.	11.973 – 11.984 (0.4714 – 0.4718)	—
Cylinder head distortion		—		0.20 (0.008)

## CYLINDER + PISTON + PISTON RING

Unit: mm (in)

ITEM	STANDARD	LIMIT
Compression pressure	1 200 – 1 400 kPa 12 – 14 kg/cm <sup>2</sup> 170 – 199 psi	1 000 kPa 10 kg/cm <sup>2</sup> 142 psi
Compression pressure difference	—	200 kPa 2 kg/cm <sup>2</sup> 28 psi
Piston to cylinder clearance	0.050 – 0.060 (0.0020 – 0.0024)	0.120 (0.0047)
Cylinder bore	78.000 – 78.015 (3.0709 – 3.0715)	78.080 (3.0740)
Piston diam.	77.945 – 77.960 (3.0687 – 3.0693) Measure at 15 mm (0.6 in) from the skirt end.	77.880 (3.0661)
Cylinder distortion	—	0.20 (0.008)



Unit: mm (in)

ITEM	STANDARD		LIMIT	
Piston ring free end gap	1st	N	Approx. 10 (0.39)	8 (0.31)
	2nd	N	Approx. 11.5 (0.45)	9.2 (0.36)
Piston ring end gap	1st		0.20 - 0.35 (0.008 - 0.014)	0.7 (0.03)
	2nd		0.35 - 0.50 (0.014 - 0.020)	1.0 (0.04)
Piston ring to groove clearance	1st		—	0.180 (0.007)
	2nd		—	0.150 (0.006)
Piston ring groove width	1st		1.01 - 1.03 (0.040 - 0.041)	—
	2nd		1.01 - 1.03 (0.040 - 0.041)	—
	Oil		2.01 - 2.03 (0.079 - 0.080)	—
Piston ring thickness	1st		0.97 - 0.99 (0.038 - 0.039)	—
	2nd		0.97 - 0.99 (0.038 - 0.039)	—
Piston pin bore		20.002 - 20.008 (0.7875 - 0.7877)	20.030 (0.7886)	
Piston pin O.D.		19.996 - 20.000 (0.7872 - 0.7874)	19.980 (0.7866)	

## CONROD + CRANKSHAFT

Unit: mm (in)

ITEM	STANDARD	LIMIT
Conrod small end I.D.	20.010 - 20.018 (0.7878 - 0.7881)	20.040 (0.7890)
Conrod big end side clearance	0.10 - 0.20 (0.004 - 0.008)	0.30 (0.01)
Conrod big end width	20.95 - 21.00 (0.825 - 0.827)	—
Crank pin width	21.10 - 21.15 (0.831 - 0.833)	—
Conrod big end oil clearance	0.032 - 0.056 (0.0013 - 0.0022)	0.080 (0.0031)
Crank pin O.D.	37.976 - 38.000 (1.4951 - 1.4961)	—
Crankshaft journal oil clearance	0.020 - 0.044 (0.0008 - 0.0017)	0.080 (0.0031)
Crankshaft journal O.D.	35.976 - 36.000 (1.4164 - 1.4173)	—

Unit: mm (in)

ITEM	STANDARD		LIMIT
Crankshaft thrust clearance	0.05 - 0.13 (0.002 - 0.005)		—
Crankshaft thrust bearing thickness	Left side	2.36 - 2.48 (0.093 - 0.098)	—
	Right side	2.42 - 2.44 (0.095 - 0.096)	—
Crankshaft runout	—		0.05 (0.002)

**OIL PUMP**

ITEM	STANDARD	LIMIT
Oil pump reduction ratio	1.819 (72/46 × 43/37)	—
Oil pressure (at 60°C, 140°F)	Above 300 kPa (3.0 kg/cm <sup>2</sup> , 43 psi) Below 600 kPa (6.0 kg/cm <sup>2</sup> , 85 psi) at 3 000 r/min.	—

**CLUTCH**

Unit: mm (in)

ITEM	STANDARD	LIMIT
Drive plate thickness	2.52 - 2.68 (0.100 - 0.106)	2.22 (0.087)
Driven plate distortion	—	0.10 (0.004)
Clutch spring free height	—	3.1 (0.12)
Clutch master cylinder bore	14.000 - 14.043 (0.5511 - 0.5529)	—
Clutch master cylinder piston diam.	13.957 - 13.984 (0.5495 - 0.5506)	—
Clutch release cylinder bore	35.700 - 35.762 (1.4055 - 1.4079)	—
Clutch release cylinder piston diam.	35.650 - 35.675 (1.4035 - 1.4045)	—

## TRANSMISSION + DRIVE CHAIN

Unit: mm (in) Except ratio

ITEM		STANDARD		LIMIT
Primary reduction ratio		1.565 (72/46)		—
Final reduction ratio		3.200 (48/15)		—
Gear ratios	Low	2.384 (31/13)		—
	2nd	1.631 (31/19)		—
	3rd	1.250 (25/20)		—
	4th	1.045 (23/22)		—
	Top	0.913 (21/23)		—
Shift fork to groove clearance		No.1, No.2 & No.3	0.1 – 0.3 (0.004 – 0.012)	0.50 (0.020)
Shift fork groove width		No.1, No.2 & No.3	5.0 – 5.1 (0.197 – 0.201)	—
Shift fork thickness		No.1, No.2 & No.3	4.8 – 4.9 (0.189 – 0.193)	—
Drive chain	Type	TAKASAGO:RK532GSV2		—
	Links	118 links		—
	20 – pitch length	—		319.4 (12.6)
Drive chain slack		25 – 35 (1.0 – 1.4)		—
Gearshift lever height		65 (2.6)		—

## CARBURETOR

ITEM	SPECIFICATION			
	E-01	E-02,16,21, 25,28,53	E-04	E-22
Carburetor type	MIKUNI BST40SS	←	←	←
Bore size	40 mm (1.6 in)	←	←	←
I.D.No.	41C0	41C4	42C2	41C6
Idle r/min.	1100 ± 100 r/min	←	←	←
Float height	14.7 ± 1.0 mm (0.57 ± 0.04 in)	←	←	←
Main jet (M.J.)	#125	←	←	←
Main air jet (M.A.J.)	1.2 mm	←	←	←
Jet needle (J.N.)	6ZD13-3rd	←	←	←
Needle jet (N.J.)	P – 2	←	←	←
Pilot jet (P.J.)	#40	←	←	←
By-pass (B.P.)	0.8 mm	←	←	←

Pilot outlet (P.O.)	0.7 mm	←	←	←
Valve seat (V.S.)	2.5 mm	←	←	←
Starter jet (G.S.)	#40	←	←	←
Pilot screw (P.S.)	PRE-SET (2 turns out)	←	←	PRE-SET (1 3/4 turns out)
Throttle cable play	0.5 – 1.0 mm (0.02 – 0.04 in)			

## CARBURETOR

ITEM	SPECIFICATION			
	E-34	E-15	E-17	E-24
Carburetor type	MIKUNI BST40SS	←	←	←
Bore size	40 mm (1.6 in)	←	←	←
I.D.No.	42C0	42C1	41C5	41C9
Idle r/min.	1100 ± 100 r/min	←	←	←
Float height	14.7 ± 1.0 mm (0.57 ± 0.04 in)	←	←	←
Main jet (M.J.)	#125	←	←	←
Main air jet (M.A.J.)	1.2 mm	←	←	←
Jet needle (J.N.)	6ZD13-3rd	←	←	←
Needle jet (N.J.)	P-2	←	←	←
Pilot jet (P.J.)	#40	←	←	←
By-pass (B.P.)	0.8 mm	←	←	←
Pilot outlet (P.O.)	0.7 mm	←	←	←
Valve seat (V.S.)	2.5 mm	←	←	←
Starter jet (G.S.)	#40	←	←	←
Pilot screw (P.S.)	PRE-SET (2 turns out)	←	←	←
Throttle cable play	0.5 – 1.0 mm (0.02 – 0.04 in)			

## CARBURETOR

ITEM	SPECIFICATION			
	E-03	E-33	E-18	E-39
Carburetor type	MIKUNI BST36SS	←	←	←
Bore size	36 mm (1.4 in)	←	←	←
I.D.No.	41C1	41C2	41C3	41C7
Idle r/min.	1200 ± 100 r/min	1100 ± 100 r/min	1100 ± 100 r/min	1100 ± 100 r/min
Float height	14.6 ± 1.0 mm (0.57 ± 0.04 in)	←	←	←
Main jet (M.J.)	#122.5	←	#110	#122.5
Main air jet (M.A.J.)	1.5 mm	←	←	←
Jet needle (J.N.)	5D42	5D43	5D44-3rd	←
Needle jet (N.J.)	0-8	←	0-9	←
Pilot jet (P.J.)	#30	←	#30	←
By-pass (B.P.)	0.8 mm	←	←	←
Pilot outlet (P.O.)	0.7 mm	←	←	←
Valve seat (V.S.)	2.3 mm	←	←	←
Starter jet (G.S.)	#42.5	←	←	←
Pilot screw (P.S.)	PRE-SET	←	PRE-SET (1¼ turns out)	PRE-SET (1½ turns out)
Throttle cable play	0.5 - 1.0 mm (0.02 - 0.04 in)	←	←	←

## ELECTRICAL

Unit: mm (in)

ITEM	SPECIFICATION		NOTE
Ignition timing	13° B.T.D.C. at 1 500 r/min		
	7° B.T.D.C. at 1 500 r/min		California model only
Firing order	1.2.4.3		
Spark plug	Type	NGK: JR9B	JR10B (OPT. Cold type)
	Gap	0.6 - 0.7 (0.024 - 0.028)	
Spark performance	Over 8 (0.3) at 1 atm.		
Signal coil resistance	Approx. 135 - 200Ω		Tester range: (× 100Ω)
Ignition coil resistance	Primary	⊕ tap - ⊖ tap Approx. 2.4 - 3.2Ω	Tester range: (× 1Ω)
	Secondary	Plug cap - Plug cap Approx. 30 - 40 kΩ	Tester range: (× 1kΩ)
Generator	Slip ring O.D.	Limit: 14.0 (0.55)	N.D.
	Brush length	Limit: 4.5 (0.18)	
Generator Max. output	Approx. 337.5 W at 5000 r/min		The rotation of the generator

Unit: mm (in)

ITEM		SPECIFICATION		NOTE
Regulated voltage		Above 13.5V at 5 000 r/min.		
Starter motor		Brush length	Limit: 6 (0.2)	MITSUBA
		Commutator under-cut	Limit: 0.2 (0.008)	
Starter relay resistance		3 - 5 $\Omega$		
Battery	Type designation	YB14L-A2		
	Capacity	12V 50.4 kC (14Ah)/10HR		
	Standard electrolyte S.G.	1.28 at 20°C (68°F)		
Fuse size	Headlight	20A (10A --- Only E-34)		
	Turn signal	10A		
	Ignition	10A		
	Taillight	10A		
	Power source	10A		
Circuit breaker		30A		

## WATTAGE

Unit: W

ITEM		SPECIFICATION				
		E-01, 02, 16, 18, 21, 24	E-03, 28, 33	E-04, 16, 17, 18, 21, 22, 39, 53	E-15, 25	E-34
Headlight	HI	60×2pcs.	←	60+55	60×2pcs.	35×2pcs.
	LO	55×2pcs.	←	55	←	35×2pcs.
Position light		5	←	←	←	←
Tail/Brake light		5/21×2pcs.	←	←	←	←
Turn signal light		21	←	←	←	←
Tachometer light		3	←	←	←	←
Speedometer light		3	←	←	←	←
Fuel level indicator light		3	←	←	←	←
Turn signal indicator light		3	←	←	←	←
High beam indicator light		1.7	←	←	←	←
Neutral indicator light		3	←	←	←	←
Oil pressure indicator light		1.7	←	←	←	←
License light		5	←	←	←	←

## BRAKE + WHEEL

Unit: mm (in)

ITEM		STANDARD		LIMIT
Rear brake pedal height		65 (2.6)		—
Brake disc thickness	Front	5.0 ± 0.2 (0.197 ± 0.008)		4.5 (0.18)
	Rear	6.0 ± 0.2 (0.236 ± 0.008)		5.5 (0.22)
Brake disc runout		—		0.30 (0.012)
Master cylinder bore	Front	14.000 - 14.043 (0.5511 - 0.5529)		—
	Rear	12.700 - 12.743 (0.5000 - 0.5017)		—
Master cylinder piston diam.	Front	13.957 - 13.984 (0.5495 - 0.5506)		—
	Rear	12.657 - 12.684 (0.4983 - 0.4994)		—
Brake caliper cylinder bore	Trailing	Front	33.960 - 34.010 (1.3370 - 1.3390)	—
			30.230 - 30.280 (1.1902 - 1.1921)	—
	Leading	Rear	38.180 - 38.256 (1.5031 - 1.5061)	—
Brake caliper piston diam.	Trailing	Front	33.878 - 33.928 (1.3338 - 1.3357)	—
			30.130 - 30.180 (1.1862 - 1.1882)	—
	Leading	Rear	38.098 - 38.148 (1.5000 - 1.5019)	—
Wheel rim runout	Axial	—		2.0 (0.08)
	Radial	—		2.0 (0.08)
Wheel axle runout	Front	—		0.25 (0.010)
	Rear	—		0.25 (0.010)
Tire size	Front	120/70 ZR17		—
	Rear	180/55 ZR17		—
Tire tread depth	Front	—		1.6 (0.06)
	Rear	—		2.0 (0.08)

## SUSPENSION

Unit: mm (in)

ITEM	STANDARD	LIMIT	NOTE
Front fork stroke	120 (4.7)	—	
Front fork spring free length	—	277 (10.9)	
Front fork oil level	131 (5.16)	—	
Rear wheel travel	158 (6.2)	—	
Swingarm pivot shaft runout	—	0.3 (0.01)	

## TIRE PRESSURE

COLD INFLATION TIRE PRESSURE	SOLO RIDING			DUAL RIDING		
	kPa	kg/cm <sup>2</sup>	psi	kPa	kg/cm <sup>2</sup>	psi
FRONT	230	2.30	33	230	2.30	33
REAR	250	2.50	36	250	2.50	36



## FUEL + OIL

ITEM	SPECIFICATION	NOTE
Fuel type	<ul style="list-style-type: none"> <li>Use only unleaded gasoline of at least 87 pump octane (<math>\frac{R+M}{2}</math>) or 91 octane or higher rated by the research method.</li> <li>Gasoline containing MTBE (Methyl Tertiary Butyl Ether), less than 10% ethanol, or less than 5% methanol with appropriate cosolvents and corrosion inhibitor is permissible.</li> </ul>	For U.S.A. model
	Use only unleaded gasoline of at least 87 pump octane ( $\frac{R+M}{2}$ ) or 91 octane or higher rated by the research method.	For Canada model
	Gasoline used should be graded 85-95 octane or higher. An unleaded gasoline is recommended.	For the other models
Fuel tank including reserve	18.5 L (4.8/4.1 US/Imp gal)	For California model
	20.0 L (5.3/4.4 US/Imp gal)	For Switzerland and Austria models
	22.0 L (5.8/4.8 US/Imp gal)	For the other models
reserve	4.0 L (1.1/0.9 US/Imp gal)	
Engine oil type	SAE 10W/40, API SE or SF	
Engine oil capacity	Change	4 000 ml (4.2/3.5 US/Imp qt)
	Filter change	4 200 ml (4.4/3.7 US/Imp qt)
	Overhaul	5 100 ml (5.4/4.5 US/Imp qt)
Front fork oil type	Fork oil L01	
Front fork oil capacity (each leg)	398 ml (13.5/14.0 US/Imp oz)	
Brake fluid type	DOT4	

Prepared by

**SUZUKI MOTOR CORPORATION**

Motorecycle Technical

Service Department

3rd Ed. March, 1992

1st Ed. September, 1989

Part No.: 99500-39092-03E

Printed in Japan

## FRONT SUSPENSION

### SPRING PRE-LOAD ADJUSTMENT

To change the spring pre-load, turn the adjuster ① clockwise or counterclockwise. Turning the adjuster clockwise will increase the spring preload. Turning the adjuster counterclockwise will decrease the spring pre-load. There are seven grooved lines on the side of the adjuster ① for reference. Position 7 provides the minimum spring pre-load and position 1 provides the maximum pre-load. This motorcycle is delivered from the factory with its adjuster set on position 5.

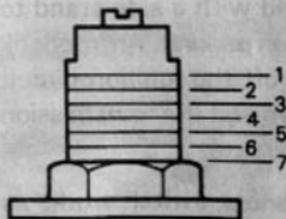
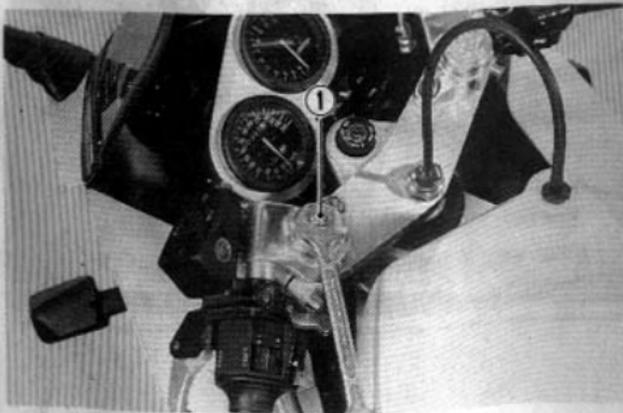

• Position 7

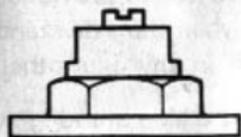

• Position 1

## FRONT SUSPENSION

### SPRING PRE-LOAD ADJUSTMENT

To change the spring pre-load, turn the adjuster ① clockwise or counterclockwise. Turning the adjuster clockwise will increase the spring preload. Turning the adjuster counterclockwise will decrease the spring pre-load. There are seven grooved lines on the side of the adjuster ① for reference. Position 7 provides the minimum spring pre-load and position 1 provides the maximum pre-load. This motorcycle is delivered from the factory with its adjuster set on position 5.

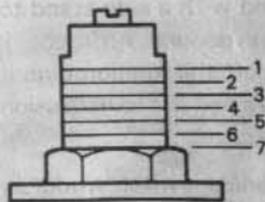

• Position 7

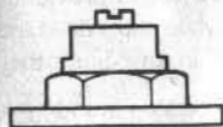

• Position 1

### DAMPING FORCE ADJUSTMENT

The extension side damping force and compression side damping force can be individually adjusted by turning the respective adjusters. To adjust the extension side damping force, turn the adjusters ②. To adjust the compression side damping force, turn the adjusters ③. Turning the adjusters clockwise will increase the damping force and turning the adjusters counterclockwise will decrease it. As you turn the adjusters, you will notice the clicks. This motorcycle is delivered from the factory with the extension side adjuster set 6 clicks turn out and the compression side adjuster set on 7 clicks turn out from the fully turned-in position.

#### **⚠ WARNING:**

Be sure to adjust the spring pre-load and damping force on both front forks equally. Making one front fork setting harder than the other will interfere with the stability of the motorcycle.

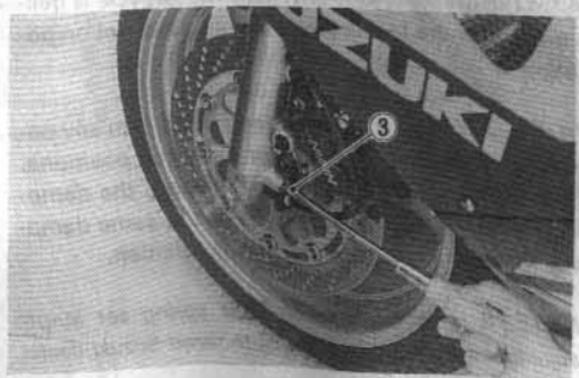
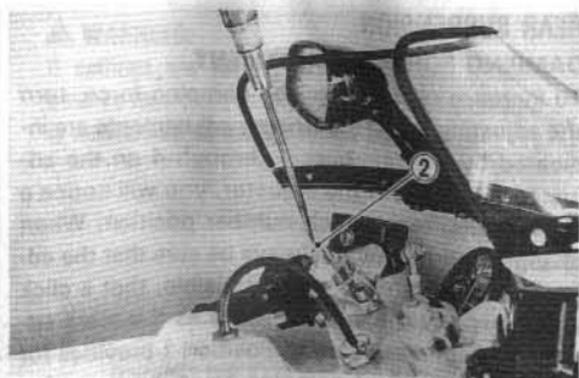

## DAMPING FORCE ADJUSTMENT

The extension side damping force and compression side damping force can be individually adjusted by turning the respective adjusters. To adjust the extension side damping force, turn the adjusters ②. To adjust the compression side damping force, turn the adjusters ③. Turning the adjusters clockwise will increase the damping force and turning the adjusters counterclockwise will decrease it. As you turn the adjusters, you will notice the clicks. This motorcycle is delivered from the factory with the extension side adjuster set 6 clicks turn out and the compression side adjuster set on 7 clicks turn out from the fully turned-in position.

### **▲ WARNING:**

Be sure to adjust the spring pre-load and damping force on both front forks equally. Making one front fork setting harder than the other will interfere with the stability of the motorcycle.

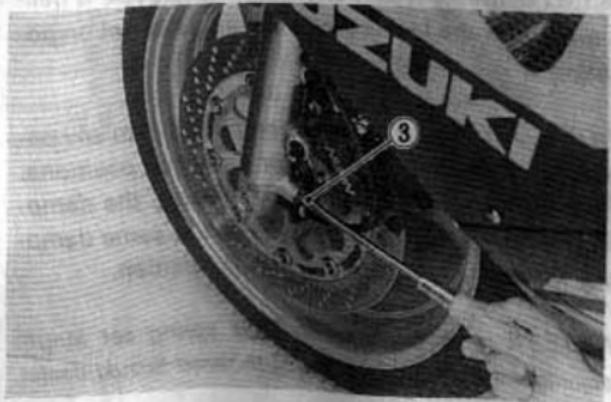
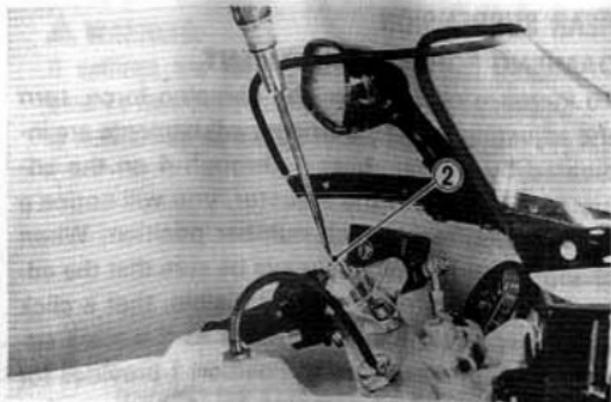

## REAR SUSPENSION

### DAMPING FORCE ADJUSTMENT

To increase or decrease the damping force, turn the adjusting ring ①. Damping adjustments are indicated by the numbers 1 through 4 on the adjuster. As you turn the adjuster, you will notice a click as you reach each number position. When changing the damping, always be sure that the adjuster stops with the number visible, that a click is noticed and the adjuster feels as if it were sitting in a detent or a notch. Position 1 provides for the least amount of damping force, and position 4 for the greatest amount. This motorcycle is delivered from the factory with its adjuster set on position 2.

**NOTE:** Do not operate rear damper unit in any position other than the click or detented positions. If positions 2 1/2, 3 1/2, etc. are used, the damping force will automatically have the same damping force as number 4 (stiffest) position.

**NOTE:** It is recommended that spring set length adjustment be done by your authorized Suzuki dealer.

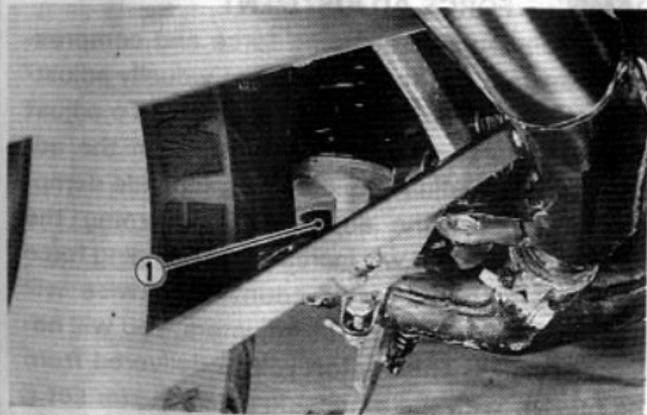

## REAR SUSPENSION

### DAMPING FORCE ADJUSTMENT

To increase or decrease the damping force, turn the adjusting ring ①. Damping adjustments are indicated by the numbers 1 through 4 on the adjuster. As you turn the adjuster, you will notice a click as you reach each number position. When changing the damping, always be sure that the adjuster stops with the number visible, that a click is noticed and the adjuster feels as if it were sitting in a detent or a notch. Position 1 provides for the least amount of damping force, and position 4 for the greatest amount. This motorcycle is delivered from the factory with its adjuster set on position 2.

**NOTE:** Do not operate rear damper unit in any position other than the click or detented positions. If positions 2 1/2, 3 1/2, etc. are used, the damping force will automatically have the same damping force as number 4 (stiffest) position.

**NOTE:** It is recommended that spring set length adjustment be done by your authorized Suzuki dealer.

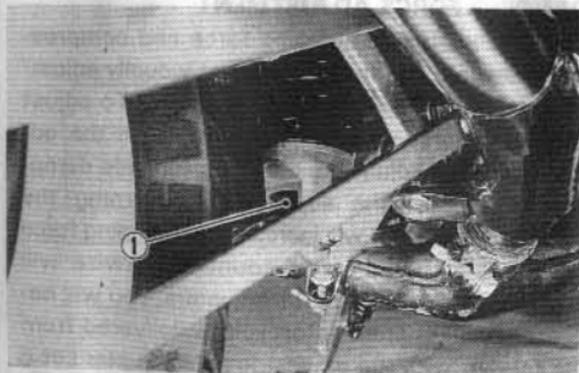

## SUSPENSION SETTING

The standard suspension settings provide comfortable ride and good handling characteristics for general, solo riding. The suspension can be adjusted for different riding conditions and rider preferences. The following chart shows basic recommended settings for the front and rear suspension units.

		Front			Rear
		Spring pre-load	Damping force		Damping force
			Extension	Compression	
Solo riding	Standard	5	6	7	2
	Softer	6	8	9	1
	Stiffer	4	4	5	3
Dual riding		4-5	3-6	6-7	2-3

### ▲ WARNING:

If settings are varied, make sure that proper balance from front suspension to rear suspension is maintained as shown in the chart.

## SUSPENSION SETTING

The standard suspension settings provide comfortable ride and good handling characteristics for general, solo riding. The suspension can be adjusted for different riding conditions and rider preferences. The following chart shows basic recommended settings for the front and rear suspension units.

### WARNING:

If settings are varied, make sure that proper balance from front suspension to rear suspension is maintained as shown in the chart.

		Front			Rear
		Spring pre-load	Damping force		Damping force
			Extension	Compression	
Solo riding	Standard	5	6	7	2
	Softer	6	8	9	1
	Stiffer	4	4	5	3
Dual riding		4-5	3-6	6-7	2-3



## REAR BRAKE LIGHT SWITCH

The rear brake light switch is located under the right frame cover. To adjust the brake light switch, raise or lower the switch so that the brake light will come on just before a pressure rise is felt when the brake pedal is depressed.



## TIRES

### **▲ WARNING:**

The tires on your motorcycle form the crucial link between your motorcycle and the road. Proper tire inflation pressure, condition, loading, and tire type are important conditions for you to monitor. Failure to follow these warnings may result in an accident due to tire failure or motorcycle control difficulty:

- check tire pressure and condition each day before you ride
- do not overload your tires
- replace tires when tread is worn to specified limits, or if tires show visual evidence of damage, such as cracks or cuts
- when replacing tires, use only tires of the specified size and type, and balance the wheel after installing a new tire
- do not use external tire repair plugs to repair tubeless tires
- read the following sections carefully

## REAR BRAKE LIGHT SWITCH

The rear brake light switch is located under the right frame cover. To adjust the brake light switch, raise or lower the switch so that the brake light will come on just before a pressure rise is felt when the brake pedal is depressed.



64

## TIRES

### ▲ WARNING:

The tires on your motorcycle form the crucial link between your motorcycle and the road. Proper tire inflation pressure, condition, loading, and tire type are important conditions for you to monitor. Failure to follow these warnings may result in an accident due to tire failure or motorcycle control difficulty:

- check tire pressure and condition each day before you ride
- do not overload your tires
- replace tires when tread is worn to specified limits, or if tires show visual evidence of damage, such as cracks or cuts
- when replacing tires, use only tires of the specified size and type, and balance the wheel after installing a new tire
- do not use external tire repair plugs to repair tubeless tires
- read the following sections carefully

## TIRE PRESSURE AND LOADING

Proper tire pressure and proper tire loading are important factors. Overloading your tires can lead to tire failure and loss of vehicle control.

Check tire pressure each day before you ride, and be sure the pressure is correct for the vehicle load according to the table below. Tire pressure should only be checked and adjusted before riding, since riding will heat up the tires and lead to higher inflation pressure readings.

### COLD TIRE INFLATION PRESSURE

TIRE	LOAD	
	SOLO RIDING WITH LIGHT OR LITTLE CARGO LOAD	DUAL RIDING OR SOLO RIDING WITH HEAVY CARGO LOAD
FRONT	2.30 kg/cm <sup>2</sup> 33 psi 230 kPa	2.50 kg/cm <sup>2</sup> 36 psi 250 kPa
REAR	2.50 kg/cm <sup>2</sup> 36 psi 250 kPa	2.90 kg/cm <sup>2</sup> 42 psi 290 kPa

*NOTE: When you detect drops in tire pressure, check the tire for nails or other punctures, or a damaged wheel rim. Tubeless tires sometimes lose pressure gradually when punctured.*

Under-inflated tires make smooth cornering difficult, and can result in rapid tire wear. Over-inflated tires have a smaller amount of tire in contact with the road, which can contribute to skidding and loss of control.

### TIRE CONDITION AND TYPE

Proper tire condition and proper tire type affect vehicle performance. Cuts or cracks in the tires can lead to tire failure and loss of vehicle control. Worn tires are susceptible to puncture failures and subsequent loss of vehicle control. Tire wear also affects the tire profile, changing vehicle handling characteristics.

Check tire conditions each day before you ride. Replace tires if tires show visual evidence of damage, such as cracks or cuts, or if tread depth is less than 1.6 mm (0.06 in) front, 2.0 mm (0.08 in) rear.

65

## TIRE PRESSURE AND LOADING

Proper tire pressure and proper tire loading are important factors. Overloading your tires can lead to tire failure and loss of vehicle control.

Check tire pressure each day before you ride, and be sure the pressure is correct for the vehicle load according to the table below. Tire pressure should only be checked and adjusted before riding, since riding will heat up the tires and lead to higher inflation pressure readings.

### COLD TIRE INFLATION PRESSURE

LOAD \ TIRE	SOLO RIDING WITH LIGHT OR LITTLE CARGO LOAD	DUAL RIDING OR SOLO RIDING WITH HEAVY CARGO LOAD
FRONT	2.30 kg/cm <sup>2</sup> 33 psi 230 kPa	2.50 kg/cm <sup>2</sup> 36 psi 250 kPa
REAR	2.50 kg/cm <sup>2</sup> 36 psi 250 kPa	2.90 kg/cm <sup>2</sup> 42 psi 290 kPa

**NOTE:** When you detect drops in tire pressure, check the tire for nails or other punctures, or a damaged wheel rim. Tubeless tires sometimes lose pressure gradually when punctured.

Under-inflated tires make smooth cornering difficult, and can result in rapid tire wear. Over-inflated tires have a smaller amount of tire in contact with the road, which can contribute to skidding and loss of control.

### TIRE CONDITION AND TYPE

Proper tire condition and proper tire type affect vehicle performance. Cuts or cracks in the tires can lead to tire failure and loss of vehicle control. Worn tires are susceptible to puncture failures and subsequent loss of vehicle control. Tire wear also affects the tire profile, changing vehicle handling characteristics.

Check tire conditions each day before you ride. Replace tires if tires show visual evidence of damage, such as cracks or cuts, or if tread depth is less than 1.6 mm (0.06 in) front, 2.0 mm (0.08 in) rear.

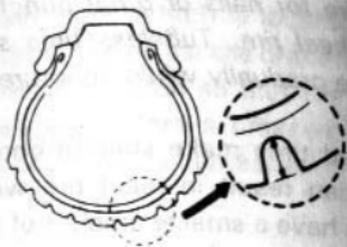

**NOTE:** *These wear limits will be reached before the wear bars molded into the tire make contact with the road.*

When you replace a tire, be sure to replace it with a tire of the size and type listed below. If you use a different size or type of tire, vehicle handling may be adversely affected, possibly resulting in loss of vehicle control.

	FRONT	REAR
SIZE	120/70 ZR17	160/60 ZR17
TYPE	MICHELIN A59X	MICHELIN M59X

Be sure to balance the wheel after repairing a puncture or replacing the tire. Proper wheel balance is important to avoid variable wheel-to-road contact, and to avoid uneven tire wear.

**▲ WARNING:**

**Proper procedures for repairing or replacing tires, and balancing wheels, are very important. These procedures should only be performed by those with the proper tools and experience. For this reason, we recommend that you have an authorized Suzuki dealer perform these procedures.**

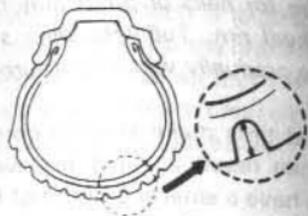

**NOTE:** These wear limits will be reached before the wear bars molded into the tire make contact with the road.

When you replace a tire, be sure to replace it with a tire of the size and type listed below. If you use a different size or type of tire, vehicle handling may be adversely affected, possibly resulting in loss of vehicle control.

	FRONT	REAR
SIZE	120/70 ZR17	160/60 ZR17
TYPE	MICHELIN A59X	MICHELIN M59X

Be sure to balance the wheel after repairing a puncture or replacing the tire. Proper wheel balance is important to avoid variable wheel-to-road contact, and to avoid uneven tire wear.

**⚠ WARNING:**

Proper procedures for repairing or replacing tires, and balancing wheels, are very important. These procedures should only be performed by those with the proper tools and experience. For this reason, we recommend that you have an authorized Suzuki dealer perform these procedures.

**⚠ CAUTION:**

The front and rear tires of this motorcycle are directional. This means they must be mounted on the wheels in a specified direction, as indicated by the arrow on the tire's side wall. Whenever the tire is dismantled or replaced, be sure that the tire is mounted in the proper direction. Installing the tire in the reverse direction will affect tire life.

**⚠ WARNING:**

Tubeless tires require different service procedures than tube type tires.

- Tubeless tires require an air-tight seal between the tire bead and wheel rim. Damage to the tire bead surface or the wheel rim inner surface will result in an air leak. Therefore, special care must be taken when removing or installing the tire. Special tire irons and rim protectors, or a specialized tire mounting machine, must be used to prevent damage.
- Repair punctures in tubeless tires by removing the tire and applying an INTERNAL patch.

- After re-installing a repaired tire, do not exceed 50 mph (80 km/h) for at least 24 hours. This will help avoid excessive heat buildup which could lead to tire repair failure and subsequent tire deflation.
- Do not operate your motorcycle at speeds above 80 mph (130 km/h) with a repaired tire. Heat buildup could lead to tire repair failure and subsequent tire deflation.
- Do not use an external tire repair plug to repair a puncture, since the plug may work loose as a result of the cornering forces experienced in a motorcycle tire.
- Replace the tire if it is punctured in the sidewall area, or if a puncture in the tread area is larger than 5 mm (3/16 in). These punctures cannot be repaired adequately.

### ▲ CAUTION:

The front and rear tires of this motorcycle are directional. This means they must be mounted on the wheels in a specified direction, as indicated by the arrow on the tire's side wall. Whenever the tire is dismantled or replaced, be sure that the tire is mounted in the proper direction. Installing the tire in the reverse direction will affect tire life.

### ▲ WARNING:

Tubeless tires require different service procedures than tube type tires.

- Tubeless tires require an air-tight seal between the tire bead and wheel rim. Damage to the tire bead surface or the wheel rim inner surface will result in an air leak. Therefore, special care must be taken when removing or installing the tire. Special tire irons and rim protectors, or a specialized tire mounting machine, must be used to prevent damage.
- Repair punctures in tubeless tires by removing the tire and applying an **INTERNAL** patch.

- After re-installing a repaired tire, do not exceed 50 mph (80 km/h) for at least 24 hours. This will help avoid excessive heat buildup which could lead to tire repair failure and subsequent tire deflation.
- Do not operate your motorcycle at speeds above 80 mph (130 km/h) with a repaired tire. Heat buildup could lead to tire repair failure and subsequent tire deflation.
- Do not use an external tire repair plug to repair a puncture, since the plug may work loose as a result of the cornering forces experienced in a motorcycle tire.
- Replace the tire if it is punctured in the sidewall area, or if a puncture in the tread area is larger than 5 mm (3/16 in). These punctures cannot be repaired adequately.