Table of Contents

| | |
|-------------------------------|----|
| Introduction | ii |
| General Information | 1 |
| Scheduled Maintenance | 2 |
| Cylinder Head | 3 |
| Clutch | 4 |
| Crankshaft | 5 |
| Bevel Box and Drive Shaft | 6 |
| Balancer | 7 |
| Transmission | 8 |
| Lubrication | 9 |
| Engine Removal and Refit | 10 |
| Fuel System/Engine Management | 11 |
| Cooling | 12 |
| Rear Suspension | 13 |
| Front Suspension | 14 |
| Brakes | 15 |
| Wheels/Tyres | 16 |
| Frame and Bodywork | 17 |
| Electrical System | 18 |

This page intentionally left blank

Introduction

Introduction

This manual is designed primarily for use by trained technicians in a properly equipped workshop. However, it contains enough detail and basic information to make it useful to the owner who desires to perform his own basic maintenance and repair work. The work can only be carried out if the owner has the necessary hand and special service tools to complete the job.

A basic knowledge of mechanics, including the proper use of tools and workshop procedures is necessary in order to carry out maintenance and repair work satisfactorily. Whenever the owner has insufficient experience or doubts his ability to do the work, an authorised Triumph dealer must undertake all adjustments, maintenance, and repair work.

In order to perform the work efficiently and to avoid costly mistakes, read the text and thoroughly familiarise yourself with procedures before starting work.

All work should be performed with great care and in a clean working area with adequate lighting.

Always use the correct special service tools or equipment specified. Under no circumstances use makeshift tools or equipment since the use of substitutes may adversely affect safe operation.

Where accurate measurements are required, they can only be made using calibrated, precision instruments.

For the duration of the warranty period, an authorised Triumph Dealer must perform all repairs and scheduled maintenance.

To maximise the life of your Motorcycle:

- Accurately follow the maintenance requirements of the periodic maintenance chart in the service manual.
- Do not allow problems to develop. Investigate unusual noises and changes in the riding characteristics of the motorcycle. Rectify all problems as soon as possible (immediately if safety related).
- Use only genuine Triumph parts as listed in the parts catalogue/parts microfiche.
- Follow the procedures in this manual carefully and completely. Do not take short cuts.
- Keep complete records of all maintenance and repairs with dates and any new parts installed.
- Use only approved lubricants, as specified in the owner's handbook, in the maintenance of the motorcycle.

How to use this manual

To assist in the use of this manual, the section title is given at the top.

Each major section starts with a contents page, listing the information contained in the section.

The individual steps comprising repair operations are to be followed in the sequence in which they appear.

Adjustment and repair operations include reference to service tool numbers and the associated illustration depicts the tool.

Where usage is not obvious, the tool is shown in use.

Adjustment and repair operations also include reference to wear limits, relevant data, torque figures, specialist information and useful assembly details.

Warning, Caution and Note

Particularly important information is presented in the following form:

| |
|---|
|  Warning |
| This warning symbol identifies special instructions or procedures which, if not correctly followed, could result in personal injury, or loss of life. |

| |
|---|
|  Caution |
| This caution symbol identifies special instructions or procedures which, if not strictly observed, could result in damage to or destruction of equipment. |

Note:

- **This note symbol indicates points of particular interest for more efficient and convenient operation.**

Tampering with Noise Control System Prohibited

Owners are warned that the law may prohibit:

- a) The removal or rendering inoperative by any person other than for purposes of maintenance, repair or replacement, of any device or element of design incorporated into any new vehicle for the purpose of noise control prior to its sale or delivery to the ultimate purchaser or while it is in use; and
- b) the use of the vehicle after such device or element of design has been removed or rendered inoperative by any person.

References

References to the left-hand or right-hand side given in this manual are made when viewing the motorcycle from the rear.

Operations covered in this manual do not always include reference to testing the motorcycle after repair. It is essential that work is inspected and tested after completion and if necessary a road test of the motorcycle is carried out particularly where safety related items are concerned.

Dimensions

The dimensions quoted are to design engineering specification with service limits where applicable.

During the period of running-in from new, certain adjustments may vary from the specification figures given in this manual. These will be reset by the dealer at the 500 mile/800 km service, and thereafter should be maintained at the figures specified in this manual.

Repairs and Replacements

Before removal and disassembly, thoroughly clean the motorcycle. Any dirt entering the engine or other parts will work as an abrasive and shorten the life of the motorcycle. Particular attention should be paid when installing a new part, that any dust or metal filings are cleared from the immediate area.

Force

Common sense should dictate how much force is necessary in assembly and disassembly. If a part seems especially difficult to remove or install, stop and examine what may be causing the problem. Never lever a component as this will cause damage both to the component itself and to the surface being levered against.

Whenever tapping to aid removal of an item is necessary, tap lightly using a hide or plastic faced mallet.

Edges

Watch for sharp edges, especially during engine disassembly and assembly. Protect the hands with industrial quality gloves.

When replacement parts are required, it is essential that only genuine Triumph parts are used.

Safety features and corrosion prevention treatments embodied in the motorcycle may be impaired if other than genuine Triumph parts are fitted. In certain territories, legislation prohibits the fitting of parts not to the manufacturer's specification.

Tightening procedure

Generally, when installing a part with several bolts, nuts or screws, they should all be started in their holes and tightened to a snug fit, evenly and in a cross pattern. This is to avoid distortion of the part and/or causing gas or oil leakage. Conversely, bolts, nuts, or screws, should all be loosened (in sequence if specified) by about a quarter of a turn and then removed.

Where there is a tightening sequence specified in this Service Manual, the bolts, nuts, or screws must be tightened in the order and by the method indicated.

Torque wrench setting figures given in this Manual must be observed. The torque tools used must be of accurate calibration.

Locking devices, where specified, must be fitted. If the efficiency of a locking device is impaired during removal it must be renewed. This applies particularly to micro-encapsulated fixings which must always be replaced if disturbed. Where necessary, the text in this manual will indicate where such a fixing is used.

This page intentionally left blank

1 General Information

Table of Contents

| | |
|--|------|
| Ignition System Safety Precautions | 1-3 |
| Dangerous Substances..... | 1-3 |
| Fluoroelastomers | 1-3 |
| Oils | 1-3 |
| Health Protection Precautions | 1-3 |
| Environmental Protection Precautions | 1-4 |
| Brakes..... | 1-4 |
| Safety Instructions | 1-5 |
| Jacking and lifting | 1-5 |
| Precautions against damage | 1-5 |
| Coolant | 1-5 |
| Cleaning components | 1-6 |
| Lubrication | 1-6 |
| Joints and joint faces | 1-6 |
| Gaskets, O-rings..... | 1-6 |
| Liquid gasket, non-permanent locking agent | 1-6 |
| Screw Threads | 1-6 |
| Locking Devices | 1-7 |
| Fitting a split pin | 1-7 |
| Circlips, retaining rings | 1-7 |
| Self locking nuts | 1-7 |
| Encapsulated bolt..... | 1-7 |
| Oil and grease seals..... | 1-7 |
| Press | 1-7 |
| Ball bearing..... | 1-7 |
| Fuel Handling Precautions | 1-7 |
| General..... | 1-7 |
| Petrol - Gasoline..... | 1-8 |
| Fuel tank removal..... | 1-8 |
| Chassis repairs..... | 1-8 |
| Electrical Precautions | 1-9 |
| Battery disconnecting | 1-9 |
| Disciplines..... | 1-9 |
| Electrical wires | 1-10 |
| Inspection | 1-10 |

General Information

| | |
|---|------|
| Replacement Parts | 1-10 |
| Service data | 1-10 |
| Specification | 1-10 |
| Service tools | 1-11 |
| Special service tools: | 1-11 |
| Torque Wrench Settings | 1-20 |
| Cylinder head area | 1-20 |
| Clutch | 1-20 |
| Crankshaft and crankcases | 1-20 |
| Engine Covers | 1-20 |
| Transmission | 1-21 |
| Lubrication System | 1-21 |
| Cooling System | 1-21 |
| Fuel System, Exhaust System and Airbox | 1-22 |
| Rear Suspension | 1-22 |
| Front Suspension | 1-22 |
| Wheels | 1-22 |
| Front Brakes | 1-23 |
| Rear Brakes | 1-23 |
| Footrests and Control Plates | 1-23 |
| Bodywork | 1-24 |
| Electrical | 1-24 |
| Routings | 1-25 |
| Clutch Cable Routing | 1-25 |
| Handlebar Cable Routing | 1-26 |
| Main Wiring Harness Routing | 1-27 |
| Rear Mudguard Harness Routing | 1-28 |
| Front Brake Hose Routing | 1-29 |
| Rear Brake Pipe and Hose Routing | 1-30 |
| Throttle Cable Routing | 1-31 |
| Fuel Hose and Fuel Tank Breather Hose Routing (non-evaporative emission control versions) | 1-32 |
| Fuel Hose and Evaporative/Fuel Tank Breather Hose Routing | 1-33 |

Ignition System Safety Precautions



The ignition system produces extremely high voltages. Do not touch any part of the ignition system or any cables while the engine is running. An electric shock caused by contact with the ignition system may lead to illness, injury or death.



Wearers of surgically implanted heart pacemaker devices should not be in close proximity to ignition circuits and or diagnostic equipment. The ignition system and any diagnostic equipment may interrupt the normal operation of such devices causing illness or death.

Dangerous Substances



Many liquids and other substances used in motor vehicles are poisonous and should under no circumstances be consumed and should, as far as possible, be kept from contact with the skin. These substances among others include acid, anti-freeze, asbestos, brake fluid, fuel, lubricants, and various adhesives. Always pay close attention to the instructions printed on labels and obey the instructions contained within. These instructions are included for your safety and well-being.
NEVER DISREGARD THESE INSTRUCTIONS!

Fluoroelastomers



Fluoroelastomer material is used in the manufacture of various seals in Triumph motorcycles.

In fire conditions involving temperatures greater than 315°C this material will decompose and can then be potentially hazardous. Highly toxic and corrosive decomposition products, including hydrogen fluoride, carbonyl fluoride, fluorinated olefins and carbon monoxide can be generated and will be present in fumes from fires.

In the presence of any water or humidity hydrogen fluoride may dissolve to form extremely corrosive liquid hydrofluoric acid.

If such conditions exist, do not touch the material and avoid all skin contact. Skin contact with liquid or decomposition residues can cause painful and penetrating burns leading to permanent, irreversible skin and tissue damage.

Oils



The engine and bevel box oils may be hot to the touch. Contact with hot oil may cause the skin to be scalded or burned.



Prolonged or repeated contact with engine oil can lead to skin dryness, irritation and dermatitis. In addition used engine oil contains potentially harmful contaminants which can cause cancer. Wear suitable clothing and avoid skin contact.

Health Protection Precautions

- Avoid prolonged and repeated contact with oils, particularly used engine oils.
- Wear protective clothing, including impervious gloves where practicable.
- Do not put oily rags in pockets.
- Overalls must be cleaned regularly. Discard heavily soiled clothing and oil impregnated footwear.
- First aid treatment should be obtained immediately for open cuts and wounds. Always

General Information

be aware of who your nearest first-aider is and where the medical facilities are kept.

- Use barrier creams, applying before each work period to protect the skin from the effects of oil and grease and to aid removal of the same after completing work.
- Wash with soap and water to ensure all oil is removed (skin cleansers and nail brushes will help). Preparations containing lanolin replace the natural skin oils which have been removed.
- Do not use petrol, kerosene, diesel fuel, gas oil, thinners or solvents for cleaning skin.
- If skin disorders develop, obtain medical advice without delay.
- Where practicable, de-grease components prior to handling.

Warning

Any risk of eye injury must be avoided. Always wear eye protection when using a hammer, air line, cleaning agent or where there is ANY risk of flying debris or chemical splashing.

Environmental Protection Precautions

Caution

Do not pour oil on the ground, down sewers or drains, or into water courses. To prevent pollution of water-courses etc., dispose of used oil sensibly. If in doubt contact your local authority.

Burning of used engine oil in small space heaters or boilers can be recommended only for units of approved design. If in doubt, check with the appropriate local authority and/or manufacturer of the approved appliance.

Dispose of used oil and used filters through authorised waste disposal contractors, to licensed waste disposal sites, or to the waste oil reclamation trade. If in doubt, contact your local authority for advice on disposal facilities.

Brakes

Warning

Brake fluid is hygroscopic which means it will absorb moisture from the air. Any absorbed moisture will greatly reduce the boiling point of the brake fluid causing a reduction in braking efficiency.

Replace brake fluid in line with the routine maintenance schedule. A dangerous riding condition could result if this important maintenance item is neglected!

Do not spill brake fluid onto any area of the bodywork as this will damage any painted or plastic surface.

Always use new brake fluid from a sealed container and never use fluid from an unsealed container or from one that has been previously opened.

Do not mix different brands of fluid. Check for fluid leakage around brake fittings, seals and joints.

Check regularly for brake hose damage.

FAILURE TO OBSERVE ANY OF THE ABOVE WARNINGS MAY REDUCE BRAKING EFFICIENCY LEADING TO AN ACCIDENT.

Warning

If there has been an appreciable drop in the level of the fluid in either brake fluid reservoir, consult your authorised Triumph Dealer for advice before riding.

If the brake lever or pedal feels soft when it is applied, or if the lever/pedal travel becomes excessive, there may be air in the brake lines or the brake may be defective.

It is dangerous to operate the motorcycle under such conditions and remedial action must be taken by your authorised Triumph dealer before riding the motorcycle.

Failure to take remedial action may reduce braking efficiency leading to an accident.

Warning

Use only D.O.T. 4 specification brake fluid as listed in the general information section of this manual. The use of brake fluids other than those D.O.T. 4 fluids listed in the general information section may reduce the efficiency of the braking system leading to an accident.

Failure to change the brake fluid at the interval specified in the routine maintenance schedule may reduce braking efficiency resulting in an accident.

 **Warning**

Never use mineral based grease in any part of the braking system or in any area where contact with the braking system is possible. Mineral based grease will damage the hydraulic seals in the calipers and master cylinders.

Damage caused by contact with mineral based grease may reduce braking efficiency resulting in an accident.

Safety Instructions

Jacking and lifting

 **Warning**

Always ensure that any lifting apparatus has adequate load and safety capacity for the weight to be lifted. Ensure the motorcycle is well supported to prevent any possibility of the machine falling prior during lifting or jacking or while repairs and servicing are carried out.

Never rely on a single means of support when working with the motorcycle. Use additional safety supports and straps to prevent toppling.

Do not leave tools, lifting equipment, spilt oil, etc. in a place where they could become a hazard to health. Always work in a clean, tidy area and put all tools away when the work is finished.

Precautions against damage

Avoid spilling brake fluid or battery acid on any part of the bodywork. Wash spillages off with water immediately.

Disconnect the battery earth lead before starting work, see **ELECTRICAL PRECAUTIONS**.

Always use the recommended service tool where specified.

Protect exposed bearing and sealing surfaces, and screw threads from damage.

Coolant

 **Warning**

Coolant mixture, which is blended with anti-freeze and corrosion inhibitors contains toxic chemicals which are harmful to the human body. Never swallow anti-freeze, corrosion inhibitors or any of the motorcycle coolant.

 **Warning**

Do not remove the radiator cap when the engine is hot. When the engine is hot, the coolant inside the radiator is hot and also under pressure. Contact with the pressurised coolant will cause scalds and skin damage.

 **Caution**

The coolant anti-freeze contains a corrosion inhibitor which helps prevent damage to the metal surfaces inside the cooling system. Without this inhibitor, the coolant would 'attack' the metals and the resulting corrosion would cause blockages in the cooling system leading to engine overheating and damage. Always use the correct anti-freeze as specified in the Owner's Handbook. Never use a methanol based anti-freeze as this does not contain the required corrosion inhibition properties.

 **Caution**

Distilled water must be used with the anti-freeze (see specification for anti-freeze) in the cooling system.

If hard water is used in the system, it causes scale accumulation in the water passages, and considerably reduces the efficiency of the cooling system. Reduced cooling system efficiency may lead to the engine overheating and engine damage.

General Information

Cleaning components

A high flash-point solvent is recommended to reduce fire hazard.

Always follow container directions regarding the use of any solvent.

Always use the recommended cleaning agent or equivalent.

Do not use degreasing equipment for components containing items which could be damaged by the use of this process. Whenever possible, clean components and the area surrounding them before removal. Always observe scrupulous cleanliness when cleaning dismantled components.

Lubrication

The majority of engine wear occurs while the engine is warming up and before all the rubbing surfaces have an adequate lubrication film. During assembly, oil or grease (whichever is more suitable) should be applied to any rubbing surface, which has lost its lubrication film. Old grease and dirty oil should be cleaned off. This is because used lubricants will have lost some lubrication qualities and may contain abrasive foreign particles.

Use recommended lubricants. Some oils and greases in particular should be used only in certain applications and may be harmful if used in an application for which they are not intended. This manual makes reference to molybdenum disulphide grease in the assembly of certain engine and chassis parts. Always check manufacturer recommendations before using such special lubricants.

Joints and joint faces

Assemble joints dry unless otherwise specified in this Manual.

If gaskets and/or jointing compound is recommended for use; remove all traces of old jointing material prior to reassembly. Do not use a tool which will damage the joint faces and smooth out any scratches or burrs on the joint faces using an oil stone. Do not allow dirt or jointing material to enter any tapped holes.

Gaskets, O-rings

Do not re-use a gasket or O-ring once it has been in service. The mating surfaces around the gasket should be free of foreign matter and perfectly smooth to avoid oil or compression leaks.

Liquid gasket, non-permanent locking agent

Follow manufacturer's directions for cleaning and preparing surfaces where these compounds will be used. Apply sparingly as excessive amounts of sealer may block engine oil passages and cause serious damage.

Prior to reassembly, blow through any pipes, channels or crevices with compressed air.

Warning

To prevent injury, always use eye, face and ear protection when using compressed air. Always wear protective gloves if the compressed air is to be directed in proximity to the skin.

Screw Threads

Metric threads to ISO standard are used.

Damaged nuts, bolts and screws must always be discarded.

Castellated nuts must not be slackened back to accept a split-pin, except in those recommended cases when this forms part of an adjustment.

Do not allow oil or grease to enter blind threaded holes. The hydraulic action on screwing in the bolt or stud could split the housing.

Always tighten a nut or bolt to the recommended torque figure. Damaged or corroded threads can affect the torque reading.

Unless specified, threaded fixings must always be fitted dry (no lubrication).

Warning

Never lubricate a thread unless instructed to do so. When a thread of a fixing is lubricated, the thread friction is reduced. When the fixing is tightened, reduced friction will cause overtightening and possible fixing failure. A fixing which fails in service could cause component detachment leading to loss of control and an accident.

Locking Devices

Always release locking tabs and fit new locking washers, do not re-use locking tabs.

Fitting a split pin

Always fit new split-pins of the correct size for the hole in the bolt or stud. Do not slacken back castle nuts when fitting split pin, except in those recommended cases when this forms part of an adjustment.

Always fit new roll pins of an interference fit in the hole.

Circlips, retaining rings

Replace any circlips and retaining rings that are removed. Removal weakens and deforms circlips causing looseness in the circlip groove. When installing circlips and retaining rings, take care to compress or expand them only enough to install them.

Always use the correct replacement circlip as recommended in the Triumph parts catalogue.

Self locking nuts

Self-locking nuts can be re-used, providing resistance can be felt when the locking portion passes over the thread of the bolt or stud.

DO NOT re-use self-locking nuts in critical locations, e.g. suspension components. Always use the correct replacement self-locking nut.

Encapsulated bolt

An encapsulated bolt can be identified by a coloured section of thread which is treated with a locking agent.

Unless a specified repair procedure states otherwise, encapsulated bolts cannot be reused and **MUST** be replaced if disturbed or removed.

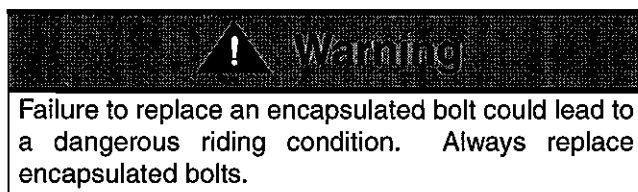

Oil and grease seals

Replace any oil or grease seals that are removed. Removal will cause damage to an oil seal which, if re-used, would cause an oil leak.

Ensure the surface on which the new seal is to run is free of burrs or scratches. Renew the component if

the original sealing surface cannot be completely restored.

Protect the seal from any surface which could cause damage over which it has to pass when being fitted. Use a protective sleeve or tape to cover the relevant surface and avoid touching the sealing lip.

Lubricate the sealing lips with a recommended lubricant. This will help to prevent damage in initial use. On dual lipped seals, smear the area between the lips with appropriate grease.

When pressing in a seal which has manufacturer's marks, press in with the marks facing out.

Seals must be pressed into place using a suitable driver. Use of improper tools will damage the seal.

Press

A part installed using a press or driver, such as a wheel bearing, should first be coated with oil or grease on its outer or inner circumference so that it will locate smoothly.

Ball bearing

When installing a ball bearing, the bearing race which is an interference fit should be pushed by a suitable driver. This prevents severe stress or damage to the load carrying components. Press a ball bearing until it touches the shoulder in the bore or on the shaft.

Press or drift seals to the depth of its housing, with the sealing lip facing the lubricant to be retained if the housing is shouldered, or flush with the face of the housing where no shoulder is provided.

Fuel Handling Precautions

General

The following information provides basic precautions which must be observed if petrol (gasoline) is to be handled safely. It also outlines other areas of risk which must not be ignored. This information is issued for basic guidance only and, if in doubt, appropriate enquiries should be made of your local Fire Officer.

General Information

Petrol - Gasoline

When petrol (gasoline) evaporates it produces 150 times its own volume in vapour which when diluted with air becomes a readily ignitable mixture. The vapour is heavier than air and will always fall to the lowest level. It can readily be distributed throughout any indoor environment by air currents, consequently, even a small spillage of petrol (gasoline) is potentially very dangerous.

Warning

Petrol (gasoline) is highly flammable and can be explosive under certain conditions. When opening the fuel tank cap always observe all the following items;

Turn the motorcycle ignition switch OFF.

Do not smoke.

Always have a fire extinguisher containing FOAM, CO₂, HALON or POWDER close at hand when handling or draining fuel or fuel systems. Fire extinguishers must also be present in areas where fuel is stored.

Always disconnect the vehicle battery, negative (black) lead first, before carrying out dismantling or draining work on a fuel system.

Whenever petrol (gasoline) is being handled, drained, stored or when fuel systems are being dismantled, make sure the area is well ventilated. All potential forms of ignition must be extinguished or removed (this includes any appliance with a pilot light). Any lead-lamps must be flame-proof and kept clear of any fuel spillage.

Warning notices must be posted at a safe distance from the site of the work to warn others that petrol is being openly handled. The notice must instruct the reader of the precautions which must be taken.

Failure to observe any of the above warnings may lead to a fire hazard which could result in personal injury.

Warning

No one should be permitted to repair components associated with petrol/gasoline without first having specialist training on the fire hazards which may be created by incorrect installation and repair of items associated with petrol/gasoline.

Repairs carried out by untrained personnel could bring about a safety hazard leading to a risk of personal injury.

Warning

Draining or extraction of petrol/gasoline from a vehicle fuel tank must be carried out in a well ventilated area.

The receptacle used to contain the petrol/ gasoline must be more than adequate for the full amount of fuel to be extracted or drained. The receptacle should be clearly marked with its contents, and placed in a safe storage area which meets the requirements of local authority regulations.

When petrol/gasoline has been extracted or drained from a fuel tank, the precautions governing naked lights and ignition sources should be maintained.

Failure to observe any of the above warnings could bring about a safety hazard leading to a risk of personal injury.

Fuel tank removal

Fuel tanks should have a 'PETROL (GASOLINE) VAPOUR' warning label attached to them as soon as they are removed from the vehicle. In all cases, they must be stored in a secured, marked area.

Chassis repairs

Warning

If the motorcycle is involved in an accident or collision it must be taken to an authorised Triumph dealer for repair or inspection. Any accident can cause damage to the motorcycle, which if not correctly repaired, may cause a second accident which may result in injury or death.

The frame must not be modified as any modification to the frame such as welding or drilling may weaken the frame resulting in an accident.

Electrical Precautions

The following guidelines are intended to ensure the safety of the operator whilst preventing damage to the electrical and electronic components fitted to the motorcycle. Where necessary, specific precautions are detailed in the relevant sections of this manual which should be referred to prior to commencing repair operations.

Equipment - Prior to commencing any test procedure on the motorcycle ensure that the relevant test equipment is working correctly and any harness or connectors are in good condition, in particular mains leads and plugs.

 **Warning**

The ignition system produces extremely high voltages. Do not touch any part of the ignition system or any cables while the engine is running. An electric shock caused by contact with the ignition system may lead to illness, injury or death.

 **Warning**

Wearers of surgically implanted heart pacemaker devices should not be in close proximity to ignition circuits and or diagnostic equipment. The ignition system and any diagnostic equipment may interrupt the normal operation of such devices causing illness or death.

 **Warning**

The battery contains harmful materials. Always keep children away from the battery whether or not it is fitted in the motorcycle. Do not jump start the battery, touch the battery cables together or reverse the polarity of the cables as any of these actions may cause a spark which would ignite battery gasses causing a risk of personal injury.

High Voltage Circuits - Whenever disconnecting live H.T. circuits always use insulated pliers. Exercise caution when measuring the voltage on the coil terminals while the engine is running, high voltage spikes can occur on these terminals.

Connectors and Harness - The engine of a motorcycle is a particularly hostile environment for electrical components and connectors. Always ensure these items are dry and oil free before disconnecting and connecting test equipment. Never force

connectors apart either by using tools or by pulling on the wiring itself. Always ensure locking mechanisms are disengaged before removal and note the orientation to enable correct reconnection. Ensure that any protective covers and substances are replaced if disturbed.

Having confirmed a component to be faulty, switch off the ignition and disconnect the battery negative (black) lead first. Remove the component and support the disconnected harness. When replacing the component keep oily hands away from electrical connection areas and push connectors home until any locking mechanism becomes fully engaged.

Battery disconnecting

Before disconnecting the battery, switch off all electrical equipment.

 **Warning**

To prevent the risk of a battery exploding and to prevent damage to electrical components ALWAYS disconnect the battery negative (black) lead first. When reconnecting the battery, always connect the positive (red) lead first, then the negative (black) lead. Always disconnect the battery when working on any part of the electrical system. Failure to observe the above warnings may lead to electrical damage and a fire hazard which could cause personal injury.

Always ensure that battery leads are routed correctly and are not close to any potential chafing points.

Disciplines

Switch off the ignition prior to making any connection or disconnection in the system. An electrical surge can be caused by disconnecting 'live' connections which can damage electronic components.

Ensure hands and work surfaces are clean and free of grease, swarf, etc. as grease collects dirt which can cause tracking or high-resistance contacts.

Prior to commencing any test, and periodically during any test, touch a good earth to discharge body static. This is because some electronic components are vulnerable to static electricity.

General Information

Electrical wires

All the electrical wires are either single-colour or two-colour and, with only a few exceptions, must be connected to wires of the same colour. On any of the two-colour wires there is a greater amount of one colour and a lesser amount of a second colour. A two-colour wire is identified by first the primary colour and then the secondary colour. For example, a yellow wire with thin red stripes is referred to as a 'yellow/red' wire; it would be a 'red/yellow' wire if the colours were reversed to make red the main colour.

Inspection

Disassembled parts should be visually inspected and replaced with new ones if there are any signs of the following:

Abrasions, cracks, hardening, warping, bending, dents, scratches, colour changes, deterioration, seizure or damage of any nature.

Replacement Parts

Warning

Only Triumph genuine parts should be used to service, repair or convert Triumph motorcycles. To ensure that Triumph genuine parts are used, always order parts, accessories and conversions from an authorised Triumph dealer. The fitting of non-approved parts, accessories or conversions may adversely affect the handling, stability or other aspects of the motorcycle operation which may result in an accident causing serious injury or death.

Warning

Always have Triumph genuine parts, accessories and conversions fitted by an authorised Triumph dealer. The fitment of parts, accessories and conversions by a dealer who is not an authorised Triumph dealer may affect the handling, stability or other aspects of the motorcycle operation which may result in an accident causing serious injury or death.

Warning

Always have Triumph approved parts, accessories and conversions fitted by a trained technician. To ensure that a trained technician is used, have an authorised Triumph dealer fit the parts. The fitment of parts, accessories and conversions by personnel other than a trained technician at an authorised Triumph dealer may affect the handling, stability or other aspects of the motorcycle operation which may result in an accident causing serious injury or death.

Service data

The service data listed in this manual gives dimensions and specifications for brand new, original parts. Where it is permissible to allow a part to exceed these figures, then the service limit is given.

The terms of the motorcycle warranty will be invalidated by the fitting of other than genuine Triumph parts.

All genuine Triumph parts have the full backing of the motorcycle warranty. Triumph dealers are obliged to supply only genuine Triumph recommended parts.

Specification

Triumph are constantly seeking to improve the specification, design and production of their motorcycles and alterations take place accordingly.

While every effort has been made to ensure the accuracy of this Manual, it should not be regarded as an infallible guide to current specifications of any particular motorcycle.

Authorised Triumph Dealers are not agents of Triumph and have no authority to bind the manufacturer by any expressed or implied undertaking or representation.

Service tools

Special service tools have been developed to facilitate removal, dismantling and assembly of certain mechanical components in a practical manner without causing damage. Some operations in this service manual cannot be carried out without the aid of the relevant service tools. Where this is the case, the tools required will be described during the procedure.

Special service tools:

T3880105 - Angular torque gauge

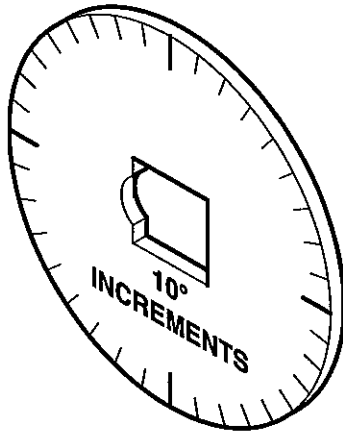

cbxt

T3880048 - Fuel pressure gauge

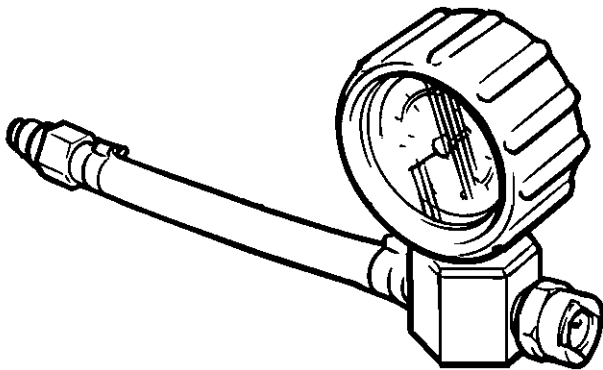

jafi

3880160-T0301 - Fork filler evacuator

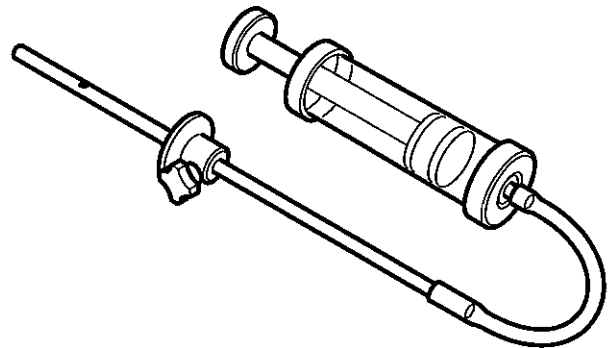

ocba

T3880312 - Oil filter wrench

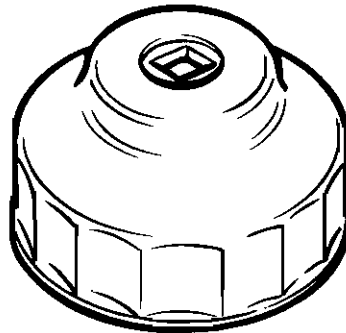

gahc

General Information

T3880250 - Diagnostic tool

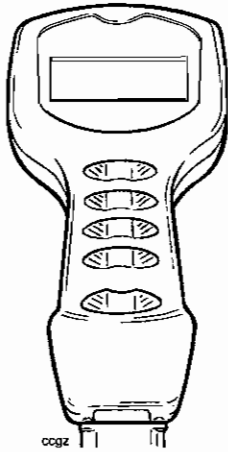

ccgz

T3880201 - Anti-rotation jig - alternator

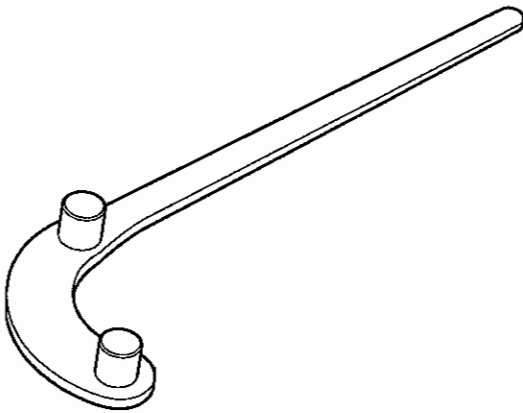

ccgy

3880025-T0301 - Clutch anti-rotation jig

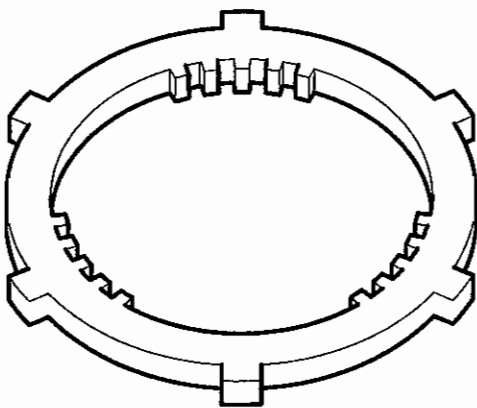

cchd

T3880200 - Puller - alternator

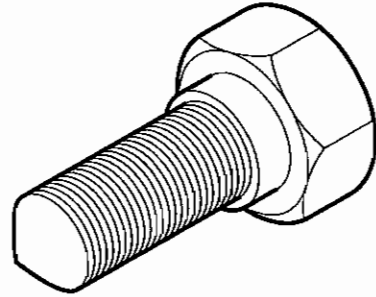

cche

T3880061 - Extractor, liners

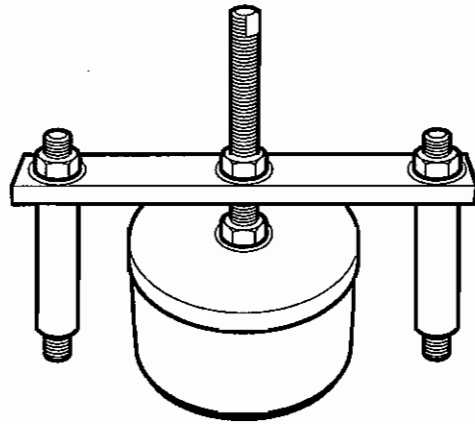

cchb

T3880062 - Castle wrench – 38 mm

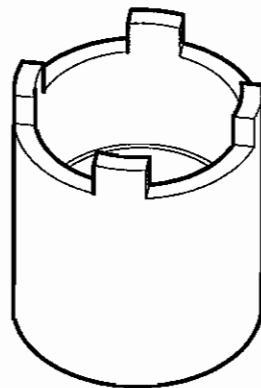

ccgu

T3880063 - Castle wrench – 31 mm

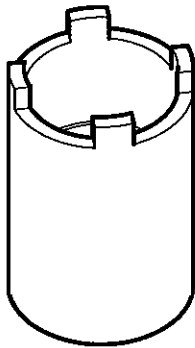

cogt

3880085-T0301 - Fork assembly rod

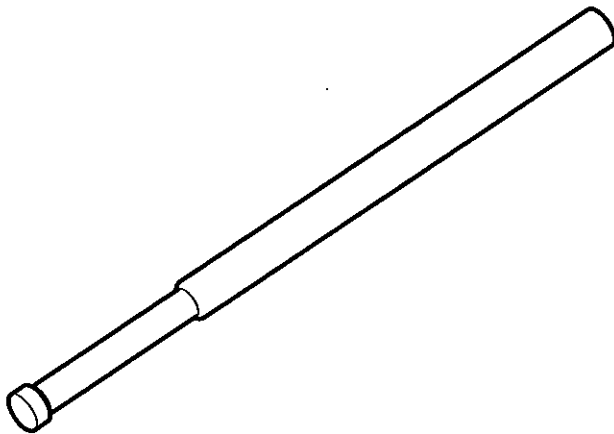

cogs

T3880067 - Fork spring compressor

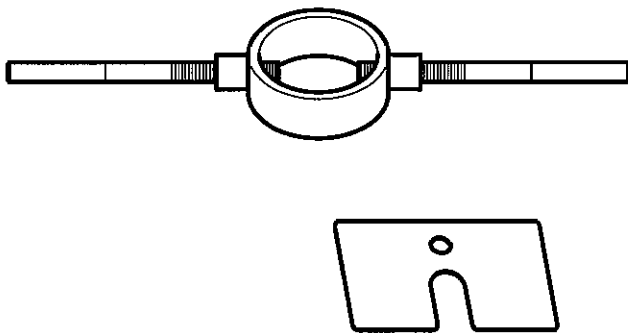

cogw

T3880064 - Drift, swinging arm bearings

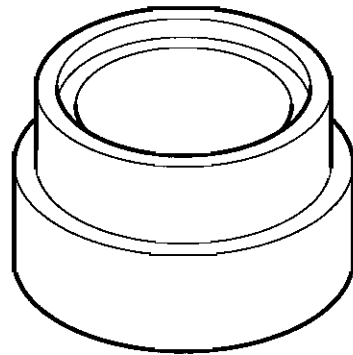

cche

3880090-T0301 - Fork service tool

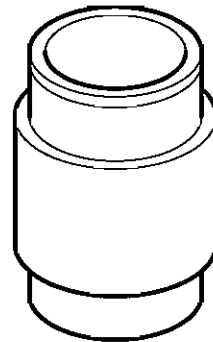

cogv

T3880202 - Cam timing jig

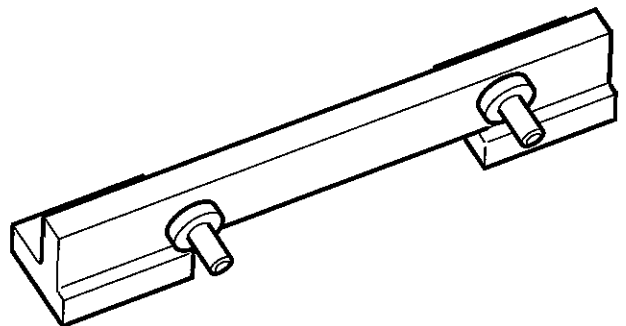

cogx

General Information

Full Specification

Rocket III

| | |
|------------------------|---------------------------|
| Engine | .3 Cylinder 12 Valve DOHC |
| Arrangement | In line, longitudinal, |
| Displacement | .2294 cc |
| Bore x Stroke | .101.6 x 94.3 mm |
| Compression Ratio | .8.7:1 |
| Cylinder Numbering | .Number 1 at front |
| Firing order | .1-2-3 |
| Max. Power (DIN 70020) | .142 PS at 5,750 rpm |
| Max. Torque | .200 Nm at 2,500 rpm |

Cylinder Head

| | | |
|-------------------------------|----------|----------------------------|
| Valve Head Dia. | In. | .37.90 mm |
| | Ex. | .32.30 mm |
| Valve Lift. | In. | .8.30 mm |
| | Ex. | .8.30 mm |
| Valve Stem Dia. | In. | .5.475 - 5.490 mm (std) |
| | Ex. | .5.475 - 5.490 mm (std) |
| Valve Guide Bore Dia. | | .5.485 - 5.500 mm (std) |
| Valve Seat Width (in head) | | .1.000 - 1.100 mm (std) |
| | | .1.500 mm (service limit) |
| Valve Seat Width (valve) | | .1.98 - 2.26 mm (std) |
| Valve Seat Angle | | .90° inclusive |
| Valve Spring Length | | .43.2 mm (std) |
| Valve Spring 'Load at Length' | In. | .180 N +/- 10 N at 36.2 mm |
| | Ex. | .180 N +/- 10 N at 36.2 mm |
| Valve Clearance | In. | .0.10 - 0.15 mm |
| | Ex. | .0.15 - 0.20 mm |
| Valve Bucket Bore Dia. | In. | .28.015 - 28.035 mm |
| | Ex. | .28.015 - 28.035 mm |
| Valve Bucket Dia. | In. | .27.978 - 27.993 mm |
| | Ex. | .27.978 - 27.993 mm |
| Valve Timing (at 1 mm lift) | | |
| Inlet | open | .12° BTDC |
| | close | .28° ABDC |
| | duration | .220° |
| Exhaust | open | .41° BBDC |
| | close | .11° ATDC |
| | duration | .232° |
| Camshaft Journal Dia. | | .22.93 - 22.96 mm (std) |
| Camshaft Journal Clearance | | .0.040 - 0.091 mm (std) |
| | | .0.13 mm (service limit) |

Full Specification

Rocket III

| | |
|---|--------------------------|
| Camshaft Journal Bore Dia. | 23.000 - 23.021 mm (std) |
| Camshaft End Float | 0.10 - 0.13 mm (std) |
| Camshaft Run-out. | 0.015 mm (std) |
| Camchain Tensioner Spring Free Length | 73.7 mm |

Clutch/Primary Drive

| | | |
|--|--------------------|--------------------------------|
| Primary Drive | Type | Gear, with backlash eliminator |
| | Reduction Ratio .. | 1.034:1 |
| Clutch | Type | Wet, multi-plate |
| No. of Friction Plates | | 10 |
| Plate Flatness Limit. | | 0.30 mm |
| Friction Plate Thickness (new) | | 3.72 – 3.88 mm |
| Friction Plate Thickness (service limit) | | 3.5 mm |
| Clutch Actuation Method. | | Cable |
| Cable Free Play (at lever) | | 2-3 mm |

Piston/Crankshaft

| | | |
|---------------------------------------|----------------------------|--------------------------------------|
| Cylinder Liner Dia. | 101.591 – 101.609 mm (std) | |
| | 101.659 mm (service limit) | |
| Piston Diameter. | 101.561 – 101.577 mm (std) | |
| | 101.511 mm (service limit) | |
| Piston Ring to Groove Clearance | Top | 0.002 – 0.006 mm (std) |
| | | 0.16 mm (service limit) |
| | Second | 0.02 – 0.06 mm (std) |
| | | 0.16 mm (service limit) |
| Piston Ring Groove Width. | Top | 1.01 – 1.03 mm (std) |
| | | 1.11 mm (service limit) |
| | Second | 1.01 – 1.03 mm (std) |
| | | 1.11 mm (service limit) |
| | Oil | 2.51 – 2.53 mm (std & service limit) |
| Piston Ring End Gap. | Top | 0.20 – 0.35 mm (std) |
| | | 0.55 mm (service limit) |
| | Second | 0.30 – 0.50 mm (std) |
| | | 0.675 mm (service limit) |
| | Oil | 0.20 – 0.70 mm (std) |
| | | 0.875 mm (service limit) |
| Gudgeon Pin Bore Dia. In Piston | | 21.994 – 22.001 mm (std) |
| | | 22.011 mm (service limit) |
| Gudgeon Pin Dia. | | 21.982 – 21.987 mm (std) |
| | | 21.972 mm (service limit) |
| Connecting Rod Small End Dia. | | 22.005 – 22.018 mm (std) |
| | | 22.028 mm (service limit) |

General Information

Full Specification

Rocket III

| | |
|---|---|
| Connecting Rod Big End Dia | 44.000 – 44.009 mm (std) |
| Connecting Rod Big End Side Clearance | 0.15 – 0.30 mm (std) 0.50 mm (service limit) |
| Crankshaft Big End Journal Dia. | 40.946 – 40.960 mm(std) 40.922 mm (service limit) |
| Crankshaft Big End Bearing Clearance | 0.035 – 0.065 mm (std) 0.100 mm (service limit) |
| Crankshaft Main Journal Dia. | 43.092 – 43.108 mm (std) 43.068 mm (service limit) |
| Crankshaft Main Bearing Clearance | 0.018 – 0.041 mm (std) 0.10 mm (service limit) |
| Crankshaft End Float | 0.05 – 0.20 mm (std) 0.40 mm (service limit) |
| Crankshaft run-out | 0.04 mm (std) 0.07 mm (service limit) |

Transmission

| | |
|--|---|
| Type | 5 Speed Constant Mesh |
| Gear Ratios | Primary 1.034:1 1st 2.929:1 2nd 1.947:1 3rd 1.435:1 4th 1.160:1 5th 0.964:1 Secondary 1.043:1 |
| Gear Selector Fork Thickness | 5.90 – 6.00 mm (std) 5.80 mm (service limit) |
| Gear Selector Groove Width | 6.05 – 6.15 mm (std) 6.30 (service limit) |
| Gear Selector Fork to Groove Clearance | 0.05 – 0.25 mm (std) 0.50 (service limit) |

Final Drive

| | |
|------------------------------------|--|
| Final Drive Type | Bevel geared crown wheel and pinion |
| Drive system | Universal-jointed shaft with torsional damper |
| Final Drive Ratio | 2.846:1 |
| Final Drive Oil | Mobilube SHC 95/W 90 fully synthetic hypoid oil (or equivalent) |
| Final Drive Oil Capacity | 0.17 litres |

Lubrication

| | |
|---|------------|
| Oil Capacity (incl. filter, dry fill) | 5.9 litres |
| Oil and filter change | 5.4 litres |

Full Specification

Rocket III

| | |
|---|---|
| Oil change only | 5.1 litres |
| Recommended Oil Approval Rating | API SH (or higher) and JASO MA |
| Viscosity | 10W/40 or 15W/50 |
| Type. | Semi or fully synthetic |
| Oil Pressure (in main gallery) | 3.00 – 3.60 Bar at 3,500 rpm |
| Oil Pump Rotor Tip Clearance | 0.15 mm (std – both pumps) 0.20 (service limit – both pumps) |
| Oil Pump Body Clearance. | 0.15 – 0.22 mm (std – both pumps) 0.20 mm (service limit – both pumps) |
| Oil Pump Rotor End Float | 0.02 – 0.07 mm (std – both pumps) 0.10 mm (service limit – both pumps) |

Ignition System

| | |
|-----------------------------------|-----------------------------|
| Type. | Digital, inductive |
| Electronic Rev-Limiter. | 6,500 rpm |
| Pick up Coil Air Gap | Fixed, not adjustable |
| Pick up Coil Resistance | 0.56 K Ω |
| Ignition Coil Type. | Inductive, twin output |
| Spark Plug Type | NGK DPR8EA9, 2 per cylinder |
| Spark Plug Gap. | 0.9 mm |

Fuel System

| | |
|-----------------------------------|-------------------------------------|
| Fuel Type. | Unleaded, 95 RON (US - 89 RON/MON) |
| Fuel Tank Capacity | 25 litres |
| Low Level Warning Lamp | 5.5 litres remaining |
| Fuel Pump Type | Submerged, electric |
| Fuel Pressure (nominal) | 3.0 Bar |
| Purge control system | Modulated, vacuum |

Fuel Injection System

| | |
|------------------------------|---|
| Type. | Multi point sequential |
| Idle Speed. | 800 rpm |
| Injector Type | Single nozzle |
| Throttle | Twin butterfly |
| Idle speed control | Stepper motor |
| Control Sensors | Coolant temperature, manifold absolute pressure (all cylinders), intake air temperature, barometric pressure, gear position, road speed, primary and secondary throttle position. |

Cooling System

| | |
|---------------------------|------------------------------------|
| Coolant Mixture. | 50% anti freeze in distilled water |
| Anti-Freeze Type. | Mobil Antifreeze |

General Information

Full Specification

Rocket III

| | |
|---|---------------|
| Cooling System Capacity | 3.2 litres |
| Radiator Cap Opening Pressure | 1.2 bar |
| Thermostat Opening Temperature | 85° C |
| Cooling Fan Switch On Temperature | |
| Temperature Gauge Sensor Resistance | 187Ω at 100°C |

Suspension

| | |
|---|--|
| Front Fork Travel | 120 mm |
| Recommended Fork Oil Grade | Kayaba 01 oil (SAE 0W) |
| Oil Level (fork fully compressed) | 89 mm |
| Oil Volume (dry fill) | 667 cm ³ +/- 4.0 cm ³ |
| Front Fork Pull Through | 0 mm (top of the outer tube flush with top yoke) |
| Fork spring rate | K = 16 N/mm |
| Rear Wheel Travel | 105 mm |

Brakes

| | |
|------------------------------------|--|
| Front type | Two four piston callipers acting on twin discs |
| Caliper Piston Dia. | 33.96 mm/30.23 mm |
| Disc Dia. | 320 mm |
| Disc Thickness | 5.0mm standard (4.0 mm service limit) |
| Disc Run-out Max. | 0.3 mm |
| Master Cylinder Diameter | 14 mm |
| Recommended Fluid | DOT 4 |
| Rear Type | |
| Caliper Piston Dia. | 32 mm |
| Disc Dia. | 316 mm |
| Disc Thickness | 7.5 mm standard (6.5 mm service limit) |
| Disc Run-out Max. | 0.15 mm |
| Master Cylinder Diameter | 12.7 mm |
| Recommended Fluid | DOT 4 |

Wheels and Tyres

| | |
|--|---|
| Front Wheel Size | MT 3.5 x 17 |
| Front Wheel Rim Axial Run-out | 0.5 mm |
| Front Wheel Rim Radial Run-out | 0.5 mm |
| Front Tyre Size | 150/80 R17 |
| Front Tyre Pressure (cold) | 34 lb/in ² |
| Front Tyre Tread Depth min. | Over 130 kmh – 3 mm (or minimum legal limit, whichever is greater) Under 130 kmh – 2 mm (or minimum legal limit, whichever is greater) |
| Rear Wheel Size | MT 7.5 x 16 |

Full Specification

Rocket III

| | |
|---|---|
| Rear Wheel Rim Axial Run-out | 0.5 mm |
| Rear Wheel Rim Radial Run-out | 0.5 mm |
| Rear Tyre Size | 240/50 R16 |
| Rear Tyre Pressure (cold) | 42 lb/in ² |
| Rear Tyre Tread Depth min. | Over 130 kmh – 3 mm (or minimum legal limit, whichever is greater) Under 130 kmh – 2 mm (or minimum legal limit, whichever is greater) |

Frame

| | |
|---|---------------|
| Frame Type | Tubular steel |
| Overall Length | 2480 mm |
| Overall Width | 880 mm |
| Wheelbase | 1690 mm |
| Seat Height | 740 mm |
| Castor | 32° |
| Trail | 152 mm |
| Dry Weight | 320 kg |
| Max. Payload (rider, passenger, luggage & accessories) | 235 kg |

Electrical Equipment

| | |
|-----------------------------|---|
| Battery Rating | 12 volt, 18 amp hour |
| Alternator Rating | 37 amps/min at 2,000 rpm 41 amp/min at 6,000 rpm |

General Information

Torque Wrench Settings

Cylinder head area

| Application | Torque (Nm) |
|--|-------------|
| Cam cover to cylinder head | 10 |
| Cam chain tensioner to crankcase | 9 |
| Cam ladder to head | See text |
| Camshaft sprocket to camshaft | 15 |
| Cam chain tensioner blade to crankcase | 18 |
| Cam chain top pad to head | See text |
| Cylinder head to crankcase | See text |
| Noise suppression bolt to cam chest | 10 |

Clutch

| Application | Torque (Nm) |
|---------------------------------|-------------|
| Clutch cover to crankcase | 9 |
| Clutch centre nut | 105 |
| Clutch pressure plate to basket | 10 |

Crankshaft and crankcases

| Application | Torque (Nm) |
|--------------------------------------|-------------|
| Connecting rod big end bolts | See text |
| Crankcase to crankcase bolts | See text |
| Transmission shaft bearing cap | See text |
| Main bearing ladder bolts | See text |
| Lubrication circuit threaded inserts | 45 |

Engine Covers

| Application | Torque (Nm) |
|---|-------------------|
| Clutch cover to crankcase | 9 |
| Clutch outer cover to inner cover | 9 |
| Alternator cover to crankcase | 9 |
| Torsional damper shaft cover to crankcase | 28 (M8) 9 (M6) |
| Cam chain inspection plug to clutch cover | 18 |

Transmission

| Application | Torque (Nm) |
|---|-------------|
| Detent wheel to selector drum | 12 |
| Selector drum bearing retaining screw | 12 |
| Spring abutment bolt | 23 |
| Gear change pinch bolt | 9 |
| Gear change pedal pivot bolt | 27 |
| Input shaft bearing retainer to crankcase | 12 |
| Output gear to output shaft | 145 |

Lubrication System

| Application | Torque (Nm) |
|--|-------------|
| Sump to crankcase | 12 |
| Sump plugs (front and rear) | 25 |
| Oil pick up strainers to sump | 12 |
| Oil pick up pipes to crankcase | 9 |
| Oil tank drain plug to sump | 25 |
| Oil pressure relief valve to crankcase | 15 |
| Oil filter adapter | 10 |
| Oil pumps to crankcase | 12 |
| Oil pump chain retainer plate to crankcase | 9 |
| Oil pressure relief valve | 15 |

Cooling System

| Application | Torque (Nm) |
|----------------------------|-------------|
| Water pump to crankcase | 10 |
| Radiator to frame | 9 |
| Thermostat housing to head | 4 |
| Fan shroud to radiator | 2 |
| Cooling system bleed screw | 10 |

General Information

Fuel System, Exhaust System and Airbox

| Application | Torque (Nm) |
|---|-------------|
| Fuel tank to frame (pivot bolt) | 9 |
| Fuel tank to frame (front fixing) | 9 |
| Fuel pump mounting plate to fuel tank | 5 |
| Fuel pump clamp screw | 2 |
| Throttle body transition piece to cylinder head | 12 |
| Exhaust headers to cylinder head | 19 |
| Exhaust headers to cat box clamp bolt | 22 |
| Exhaust cat box to frame | 27 |
| Silencer mounting bracket to frame | 27 |
| Fuel level sensor to fuel tank | 10 |
| Air filter cover to airbox | 3 |
| Airbox to bracket | 9 |

Rear Suspension

| Application | Torque (Nm) |
|---|-------------|
| Swinging arm pivot bolt – fixed (left hand) | 100 |
| Swinging arm pivot bolt – adjustable (right hand) | 15 |
| Swing arm pivot bolt lock ring (right hand) | 100 |
| Rear suspension unit upper mounting bolt | 28 |
| Rear suspension unit lower mounting bolt | 28 |

Front Suspension

| Application | Torque (Nm) |
|-----------------------------------|-------------|
| Upper yoke pinch bolt | 20 |
| Lower yoke pinch bolt | 22 |
| Fork top cap to inner tube | 30 |
| Upper yoke centre nut | 65 |
| Damping cylinder bolt | 45 |
| Handlebar clamp to top yoke | 35 |
| Handlebar clamp bolt | 26 |
| Handlebar clamp cover plate bolts | 3 |

Wheels

| Application | Torque (Nm) |
|------------------------------------|-------------|
| Front wheel spindle/axle bolt | 65 |
| Fork to wheel spindle pinch bolts | 22 |
| Rear wheel spindle flanged locknut | 110 |

Front Brakes

| Application | Torque (Nm) |
|-----------------------------------|-------------|
| Calliper to fork | 40 |
| Pad retaining pin (hexagon drive) | 18 |
| Calliper bleed screw | 5 |
| Hose to calliper | 25 |
| Master cylinder to handlebar | 15 |
| Hose to master cylinder | 25 |
| Disc to wheel | 22 |
| Fluid reservoir to bracket | 6 |

Rear Brakes

| Application | Torque (Nm) |
|------------------------------------|-------------|
| Calliper bleed screw | 8 |
| Hose to calliper | 25 |
| Master cylinder to frame | 27 |
| Master cylinder reservoir to frame | 7 |
| Hose to brake pipe joint | 25 |
| Hose to brake light switch | 15 |
| Brake pedal pivot bolt | 30 |
| Brake disc to wheel | 22 |

Footrests and Control Plates

| Application | Torque (Nm) |
|---|-------------|
| Foot rest mounting bar to engine (left and right) | 27 |
| Rear footrest to hanger | 27 |
| Side stand to engine | 40 |
| Side stand pivot bolt | 20 |
| Side stand pivot locknut | 25 |
| Front footrest end screw to footrest | 9 |
| Heel guards to control plate bar | 9 |
| Bank angle peg to footrest | 10 |

General Information

Bodywork

| Application | Torque (Nm) |
|-------------------------------------|-------------|
| Engine to frame bolts | See text |
| Front mudguard to forks | 27 |
| Front mudguard finisher to mudguard | 3 |
| Rear mudguard/covers to frame | See text |
| Rear seat to mudguard | 9 |
| Side covers to frame | 9 |
| Engine infill panels to frame | 4 |

Electrical

| Application | Torque (Nm) |
|---------------------------------|-------------|
| Starter motor to engine | 28 |
| Alternator rotor to crank | 120 |
| Alternator stator to crankcase | 12 |
| Alternator rectifier to bracket | 9 |
| Alternator cover to crankcase | 9 |
| Rear light to mudguard | 7 |
| Number plate light to bracket | 9 |
| Indicators to brackets | 9 |
| Indicator lenses to indicators | 2 |
| Headlight horizontal adjuster | 15 |
| Headlight vertical adjuster | 20 |
| Headlight bezel clamp | 4 |

Routings

Clutch Cable Routing

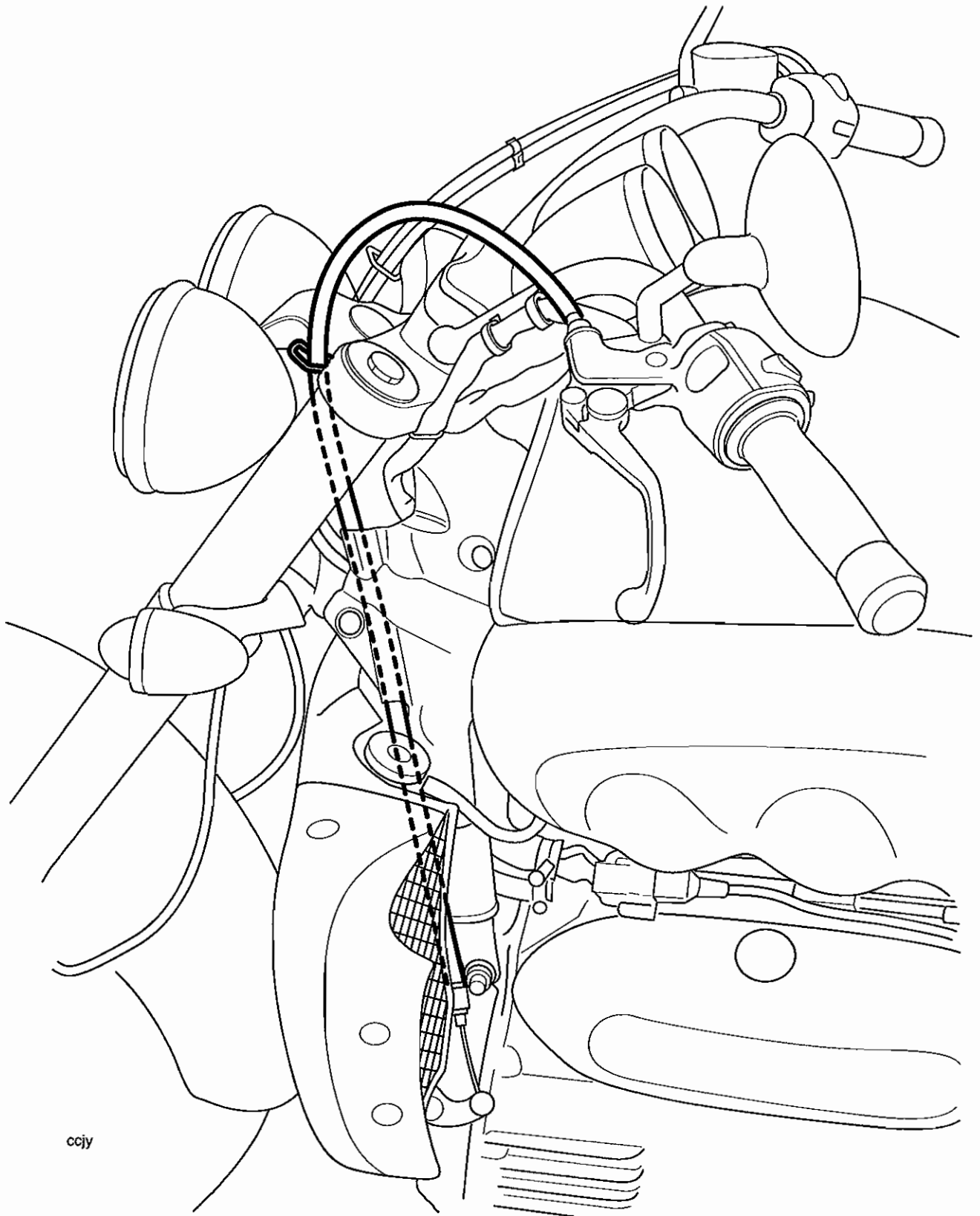

ccjy

General Information

Handlebar Cable Routing

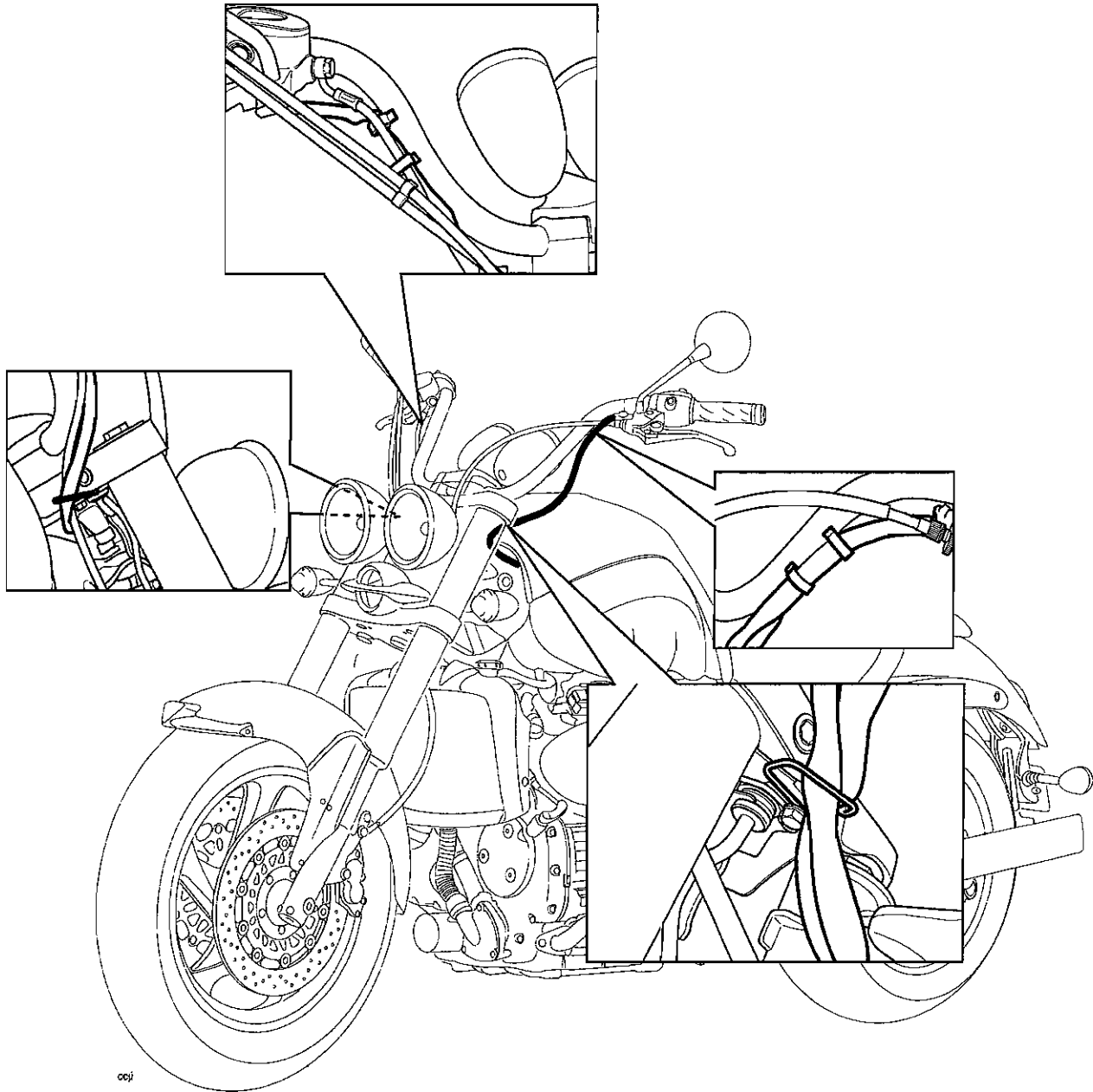

Main Wiring Harness Routing

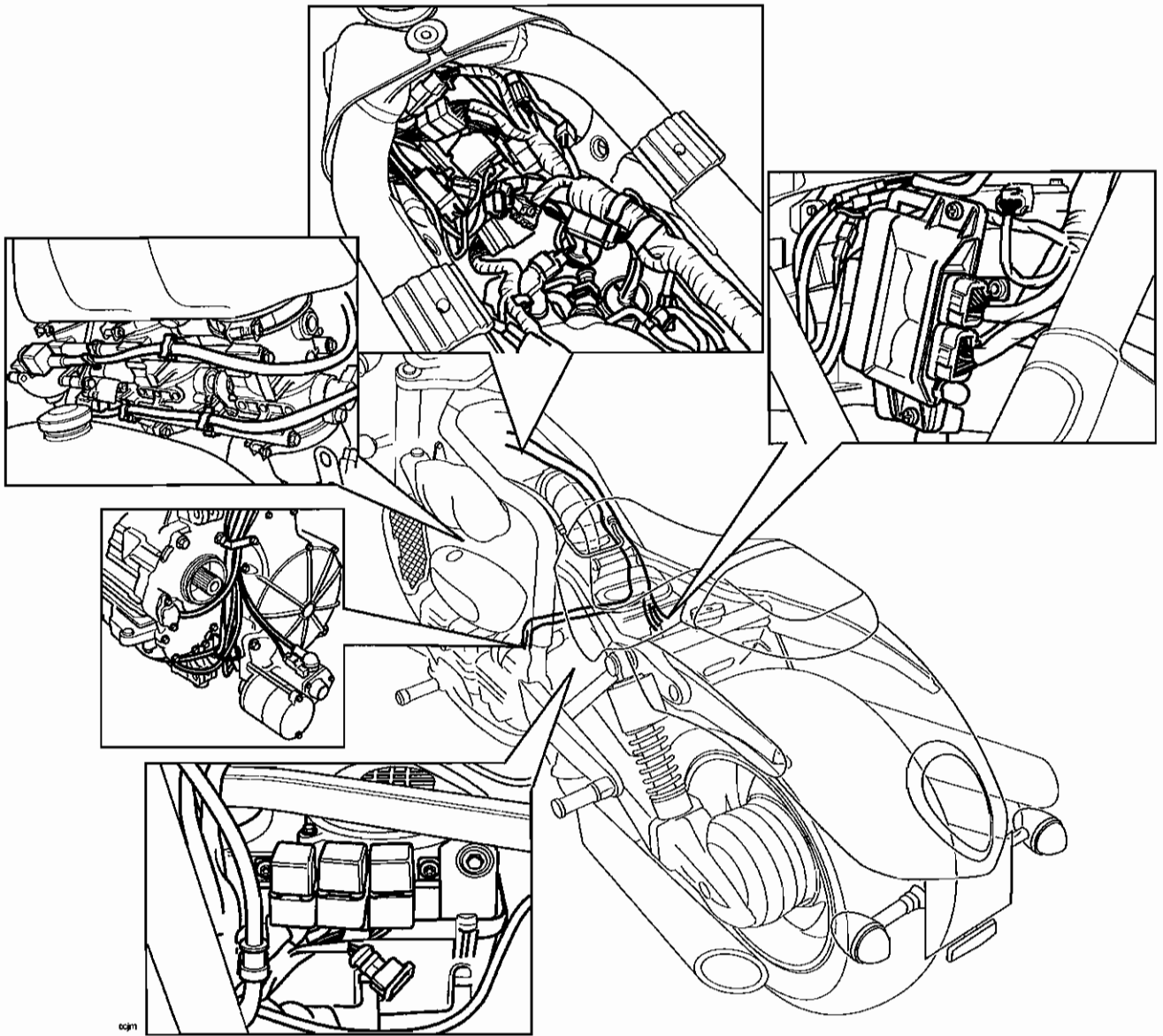

General Information

Rear Mudguard Harness Routing

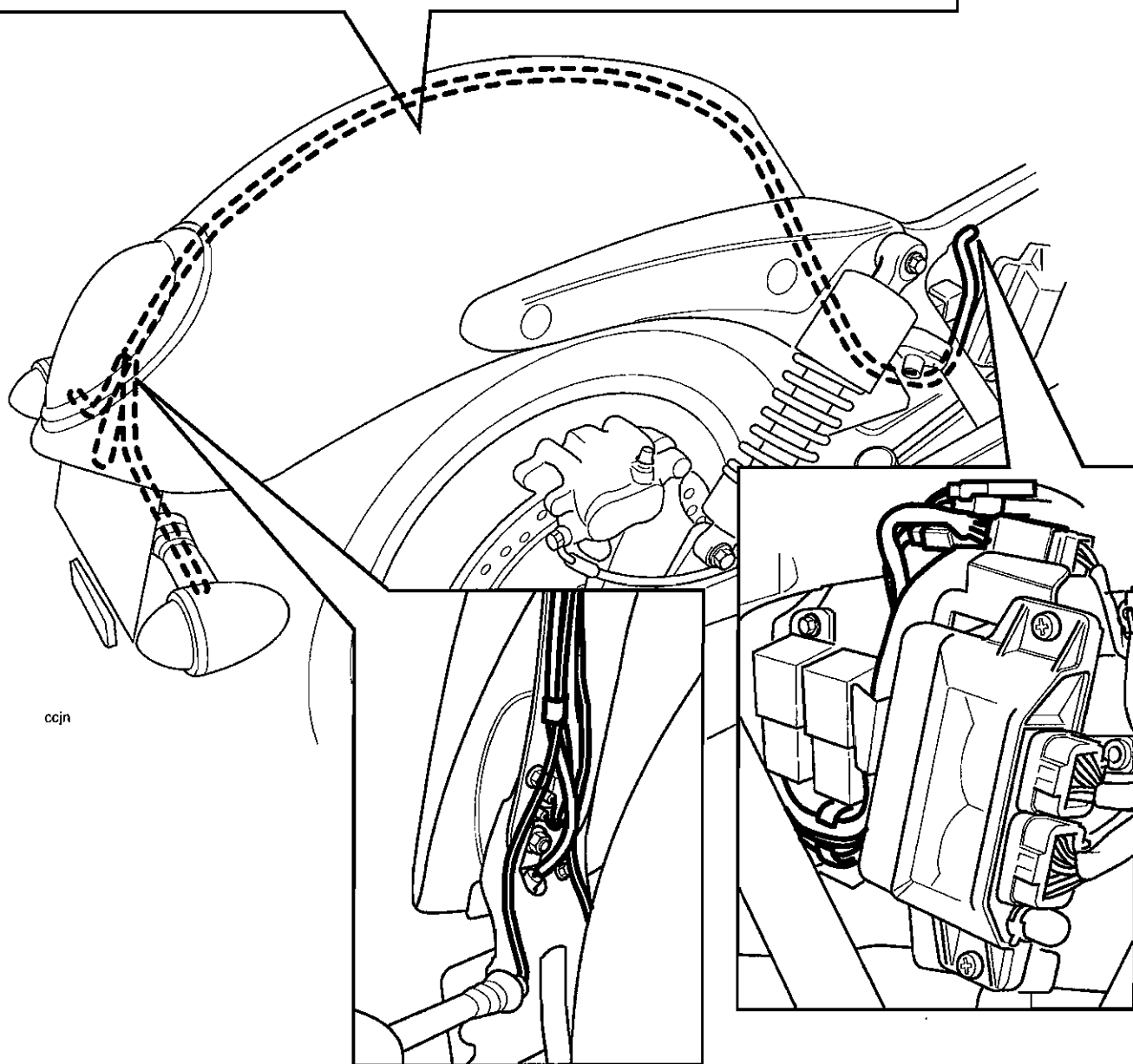
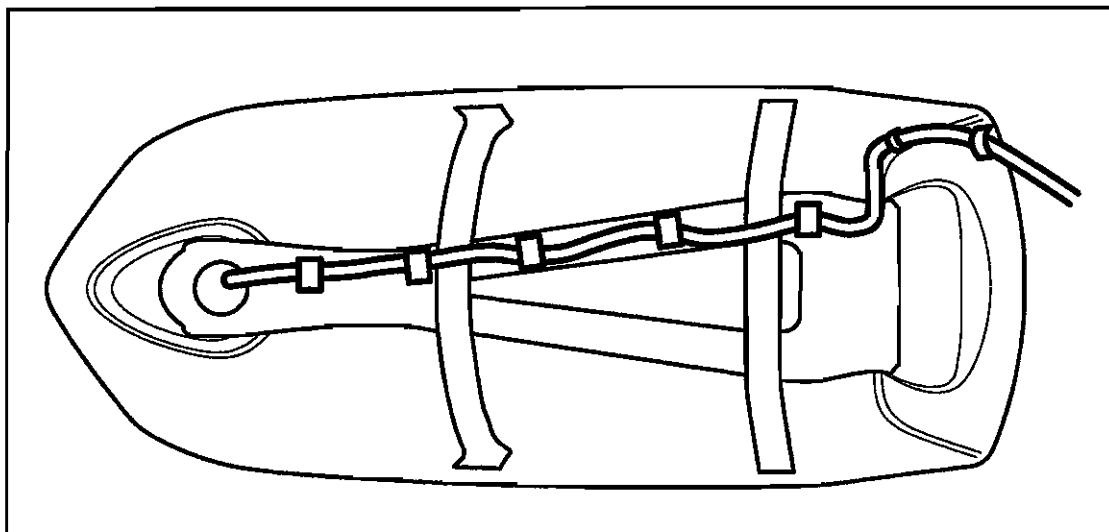

Front Brake Hose Routing

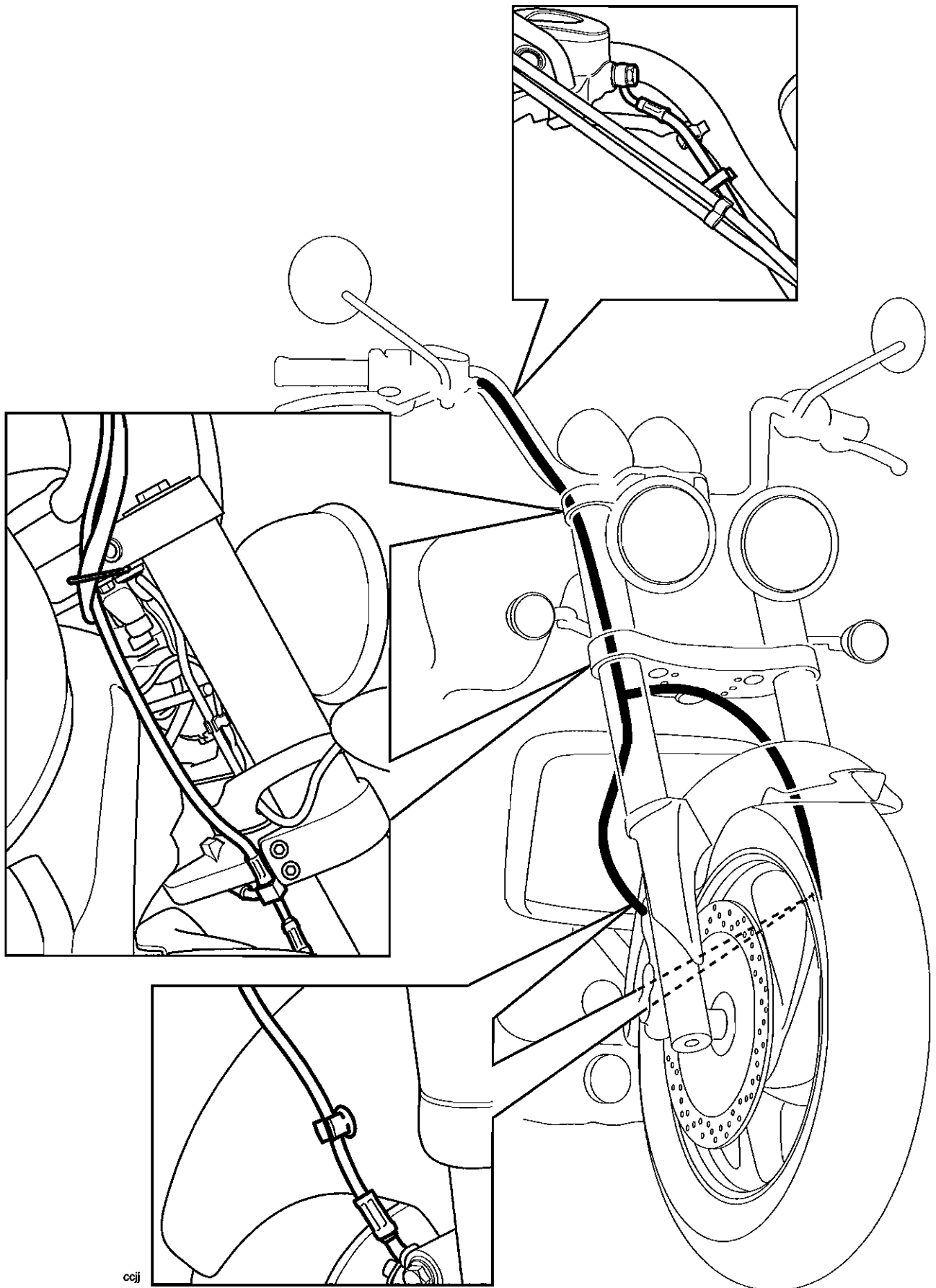

General Information

Rear Brake Pipe and Hose Routing

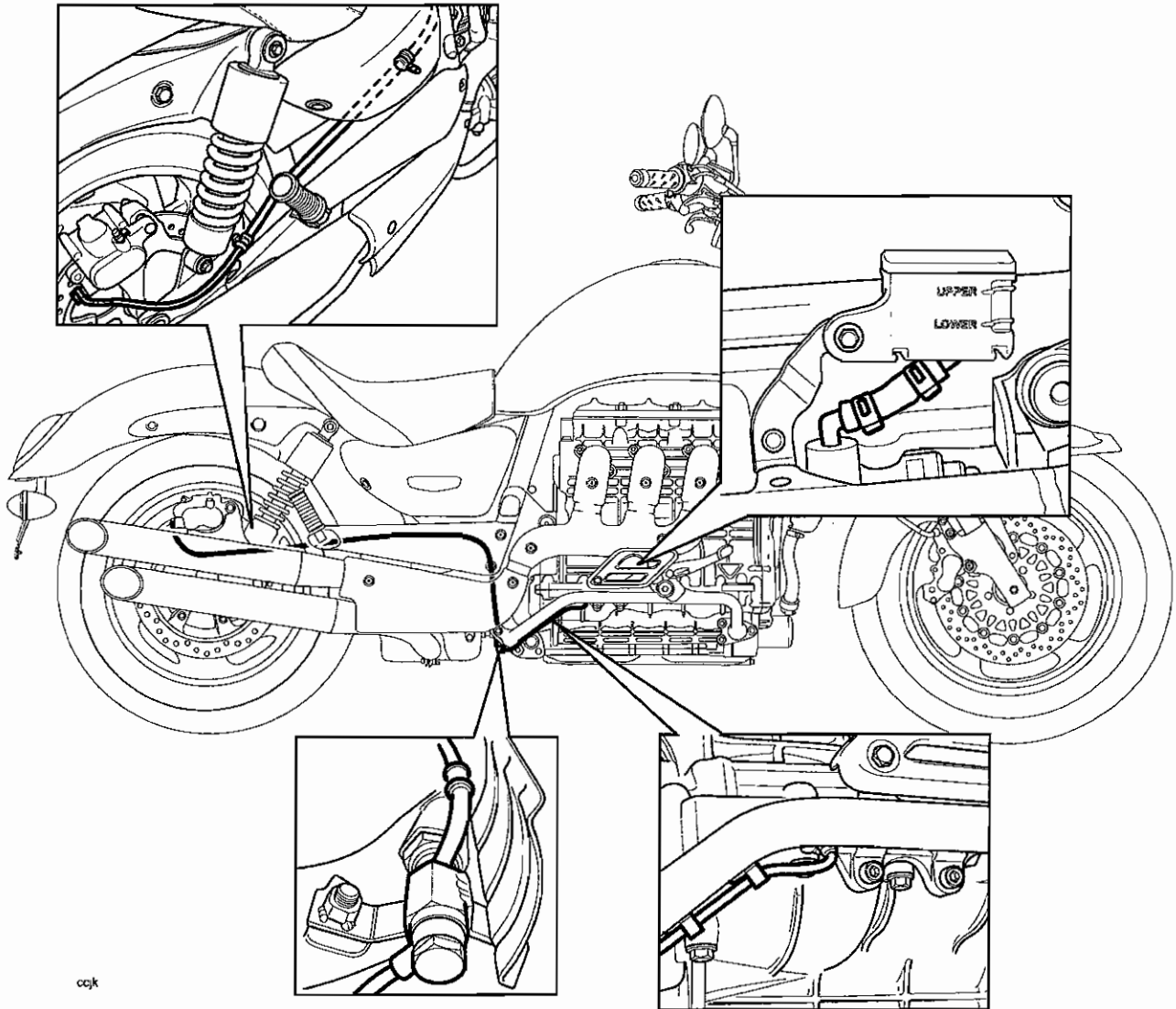

ccjk

Throttle Cable Routing

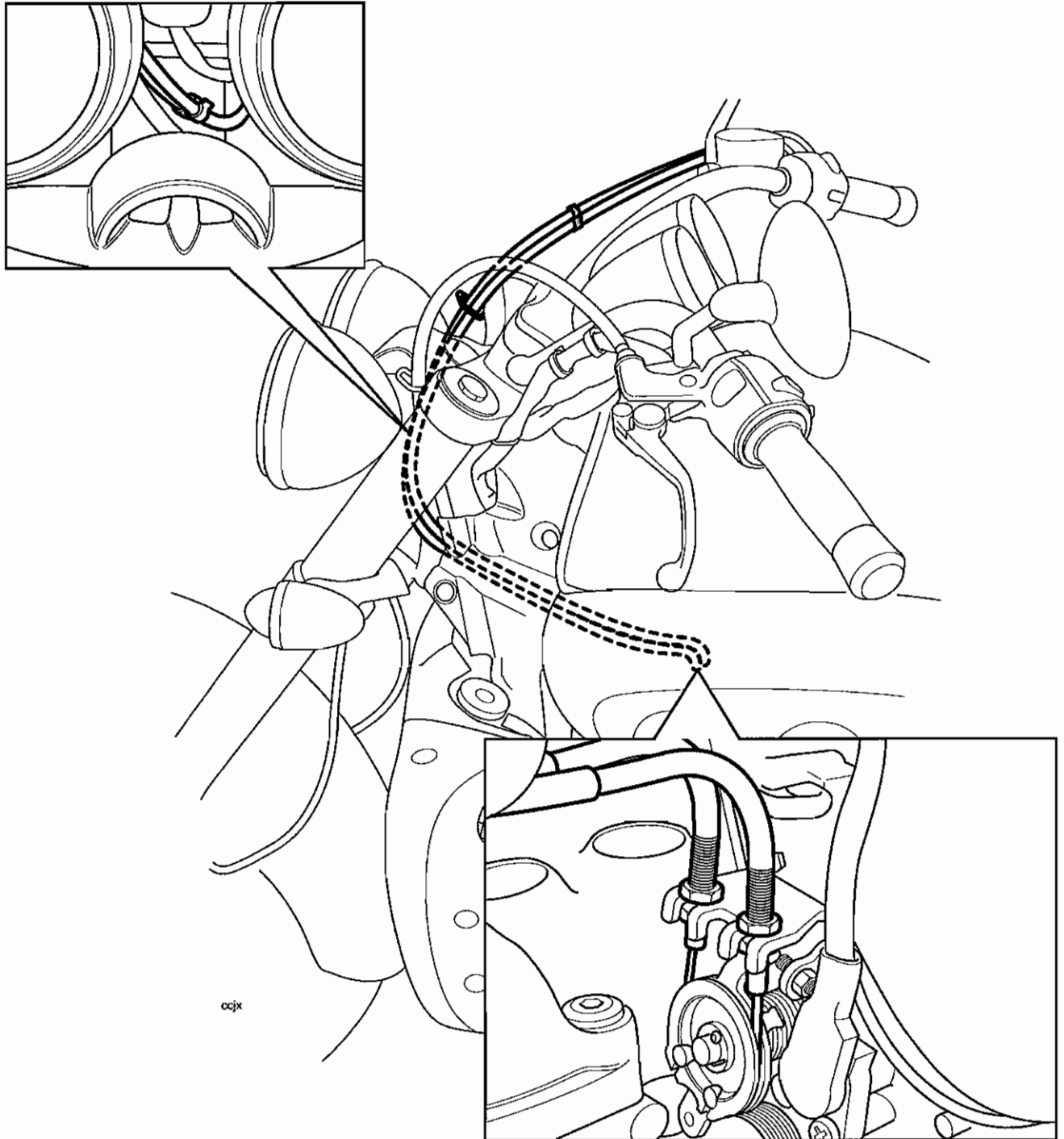

General Information

Fuel Hose and Fuel Tank Breather Hose Routing (non-evaporative emission control versions)

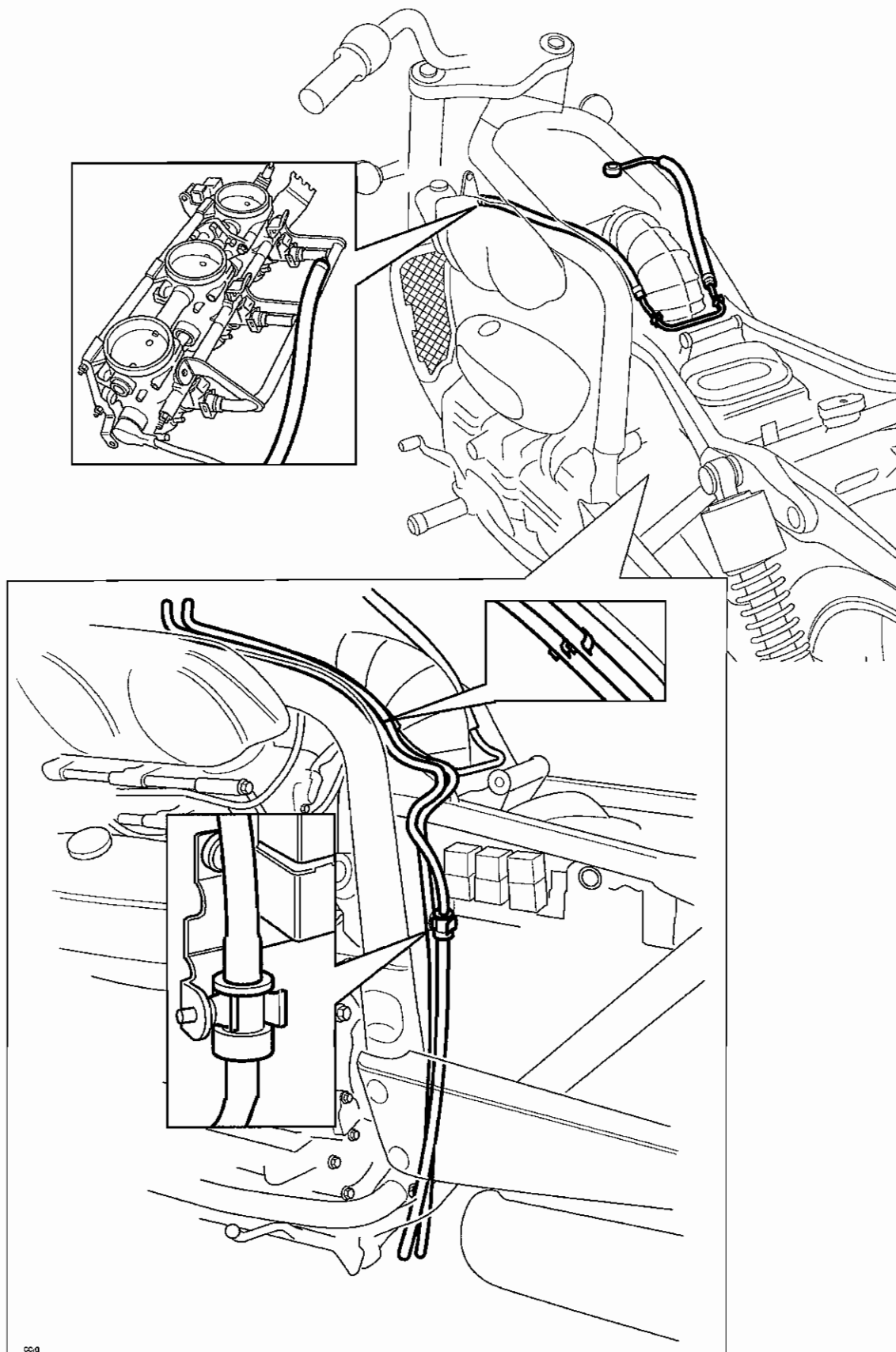

Fuel Hose and Evaporative/Fuel Tank Breather Hose Routing

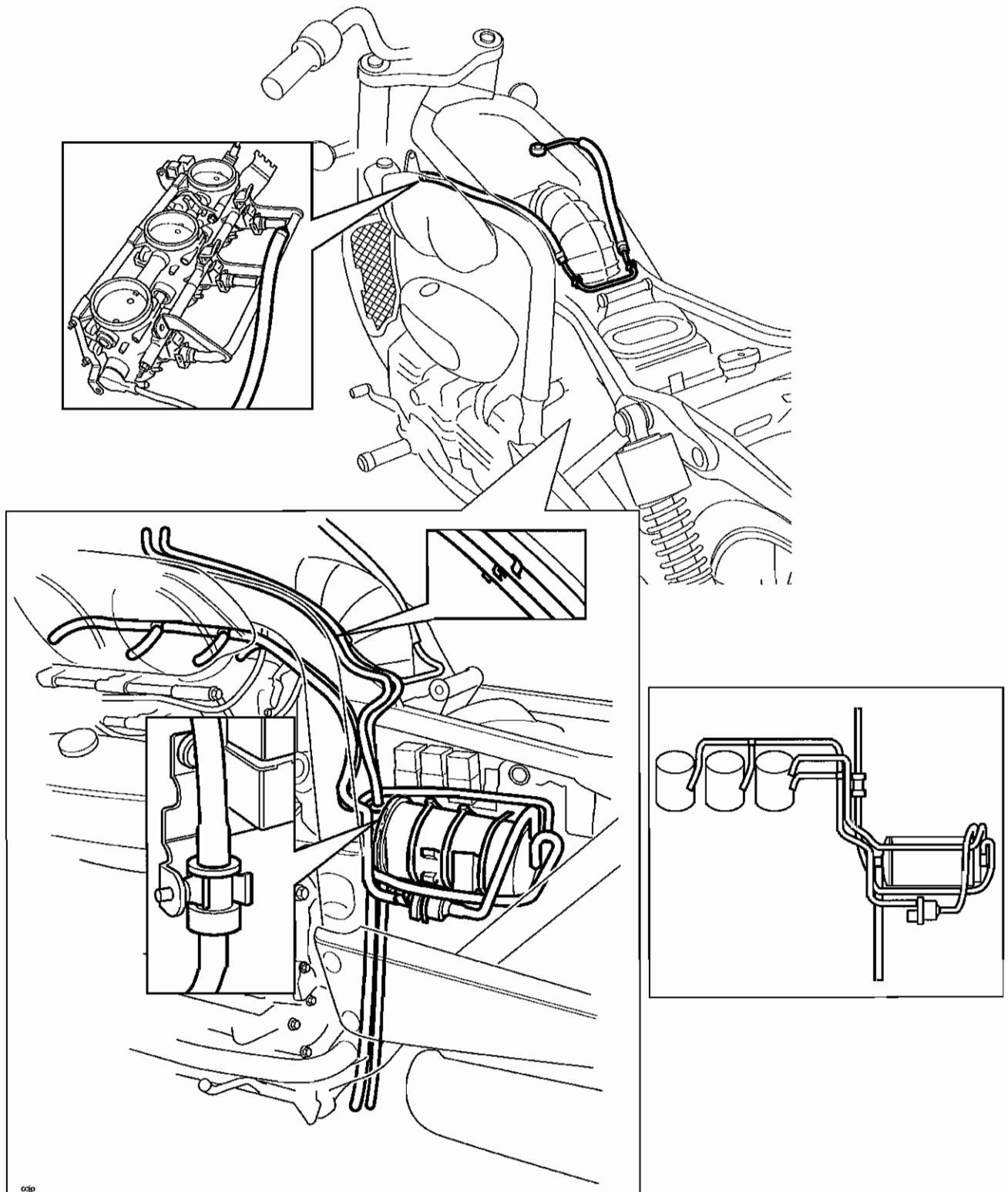

This page intentionally left blank

2 Scheduled Maintenance

Table of Contents

| | |
|---------------------------------------|-----|
| Introduction | 2-2 |
| Scheduled Maintenance Chart | 2-3 |

Scheduled Maintenance

Introduction

To maintain the motorcycle in a safe and reliable condition, the maintenance and adjustments outlined in this section must be carried out as specified in the schedule of daily checks, and also in line with the scheduled maintenance chart.

Weather, terrain and geographical location affects maintenance. The maintenance schedule should be adjusted to match the particular environment in which the vehicle is used and the demands of the individual owner. For advice on adjusting the service schedule, consult your authorised Triumph dealer.

 **Warning**

In order to correctly carry out the maintenance items listed in the scheduled maintenance chart, special tools and specialist knowledge will be required. As only an authorised Triumph dealer will have this knowledge and equipment, Triumph strongly recommends that your authorised Triumph dealer carries out all scheduled maintenance.

A dangerous riding condition could result from incorrect maintenance leading to loss of motorcycle control and an accident.

 **Warning**

All maintenance is vitally important and must not be neglected. Incorrect maintenance or adjustment may cause one or more parts of the motorcycle to malfunction. A malfunctioning motorcycle is dangerous and may lead to an accident.

 **Warning**

Triumph Motorcycles cannot accept any responsibility for damage or injury resulting from incorrect maintenance or improper adjustment carried out by the owner.

Since incorrect or neglected maintenance can lead to a dangerous riding condition, always have an authorised Triumph dealer carry out the scheduled maintenance of this motorcycle.

This page intentionally left blank

Scheduled Maintenance Chart

| Operation Description | Odometer Reading in Miles (Kms) or time period, whichever comes first. | | | | | | | |
|--|--|-------------------------|-----------------------------|------------------------------|------------------------------|------------------------------|------------------------------|------------------------------|
| | Every | 500 (800) 1 month | 10,000 (16000) 1 year | 20,000 (32000) 2 years | 30,000 (48000) 3 years | 40,000 (64000) 4 years | 50,000 (80000) 5 years | 60,000 (96000) 6 years |
| Engine - check for leaks | Day | • | • | • | • | • | • | • |
| Engine oil - renew | - | • | • | • | • | • | • | • |
| Engine oil filter - renew | - | • | • | • | • | • | • | • |
| Valve clearances - check | - | | • | | • | | • | |
| Air cleaner - renew | - | | | • | | • | | • |
| Engine ECM - check for stored DTC | - | • | • | • | • | • | • | • |
| Spark plugs - check | - | | • | • | | • | • | |
| Spark plugs - renew | - | | | | • | | | • |
| Throttle bodies - balance | - | | • | • | • | • | • | • |
| Throttle cables - check/adjust | Day | • | • | • | • | • | • | • |
| Cooling system - check for leaks | - | • | • | • | • | • | • | • |
| Coolant level - check/adjust | - | • | • | | • | | • | |
| Coolant - renew | - | | | • | | • | | • |
| Fuel system - check for leaks | Day | • | • | • | • | • | • | • |
| Lights, instruments & electrical systems - check | Day | • | • | • | • | • | • | • |
| Fuel filter - renew | - | | | • | | • | | • |
| Steering - check for free operation | Day | • | • | • | • | • | • | • |
| Headstock bearings - check/adjust | - | • | • | • | • | • | • | • |
| Headstock bearings - lubricate | - | | | • | | • | | • |
| Forks - check for leaks/smooth operation | Day | • | • | • | • | • | • | • |
| Fork oil - renew | - | | | | | • | | |
| Brake fluid levels - check | Day | • | • | • | • | • | • | • |
| Brake fluid - renew | | Every 2 years | | | | | | |
| Brake pad wear - check | Day | • | • | • | • | • | • | • |
| Brake calipers - check for leaks and seizures | - | • | • | • | • | • | • | • |
| Brake master cylinders - check for leaks | - | • | • | • | • | • | • | • |
| Final drive – check for oil leaks | - | • | • | • | • | • | • | • |
| Final drive oil - check | - | • | • | | • | | • | |
| Final drive oil - renew | - | | | • | | • | | • |
| Fasteners - inspect visually for security | Day | • | • | • | • | • | • | • |
| Wheels - inspect for damage | Day | • | • | • | • | • | • | • |
| Tyre wear/tyre damage - check | Day | • | • | • | • | • | • | • |
| Tyre pressures - check/adjust | Day | • | • | • | • | • | • | • |
| Clutch cable - check/adjust | Day | • | • | • | • | • | • | • |
| Stand – check operation | Day | • | • | • | • | • | • | • |

3 Cylinder Head

Table of Contents

| | |
|--|------|
| Exploded View - Cam Cover | 3-2 |
| Exploded View - Camshaft and Cam Drive | 3-3 |
| Exploded View - Cylinder Head | 3-4 |
| Description | 3-5 |
| Cam Cover | 3-5 |
| Removal | 3-5 |
| Installation | 3-6 |
| Cam Chain Tensioner | 3-6 |
| Removal | 3-6 |
| Inspection | 3-7 |
| Installation | 3-7 |
| Camshafts | 3-9 |
| Camshaft identification | 3-10 |
| Cam sprocket orientation | 3-10 |
| Inspection | 3-11 |
| Installation | 3-12 |
| Valve Clearances | 3-14 |
| Valve Clearance Adjustment | 3-14 |
| Cylinder Head | 3-15 |
| Inspection | 3-16 |
| Installation | 3-16 |
| Valves and Valve Stem Seals | 3-17 |
| Removal from the cylinder head | 3-17 |
| Installation | 3-17 |
| Cam Chain | 3-18 |
| Inspection | 3-18 |

Cylinder Head

Exploded View - Cam Cover

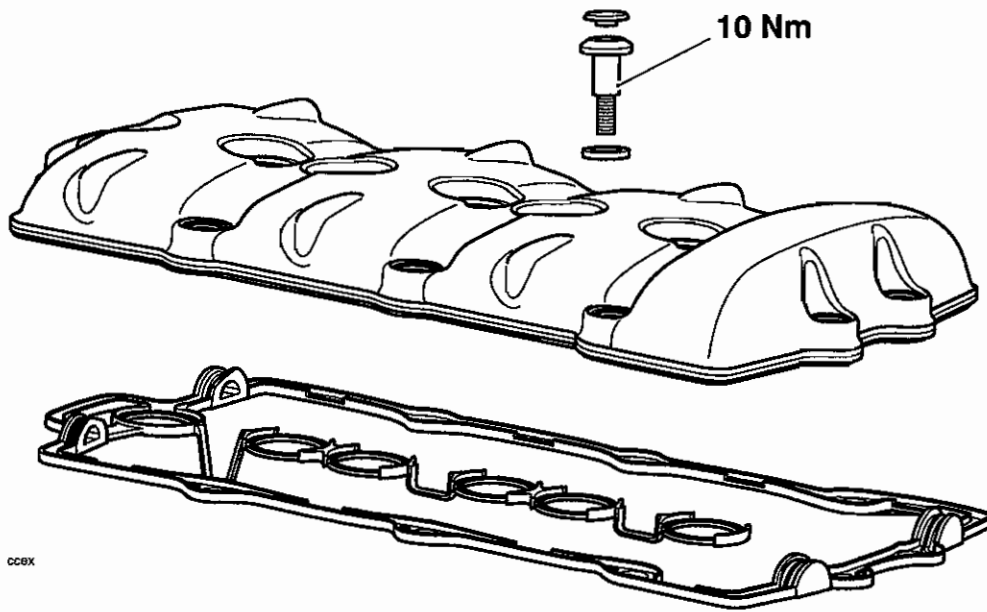

Exploded View - Camshaft and Cam Drive

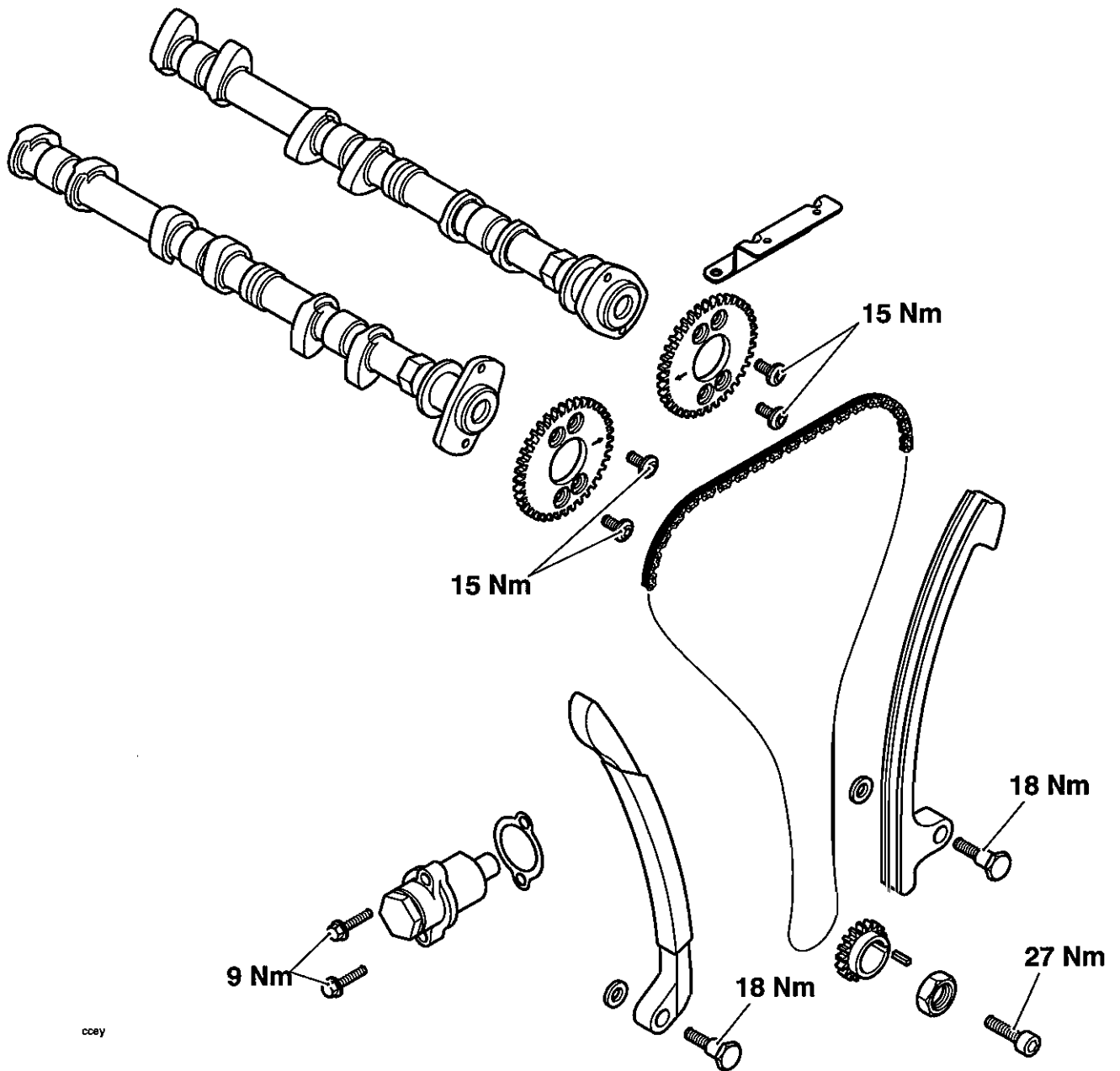

Cylinder Head

Exploded View - Cylinder Head

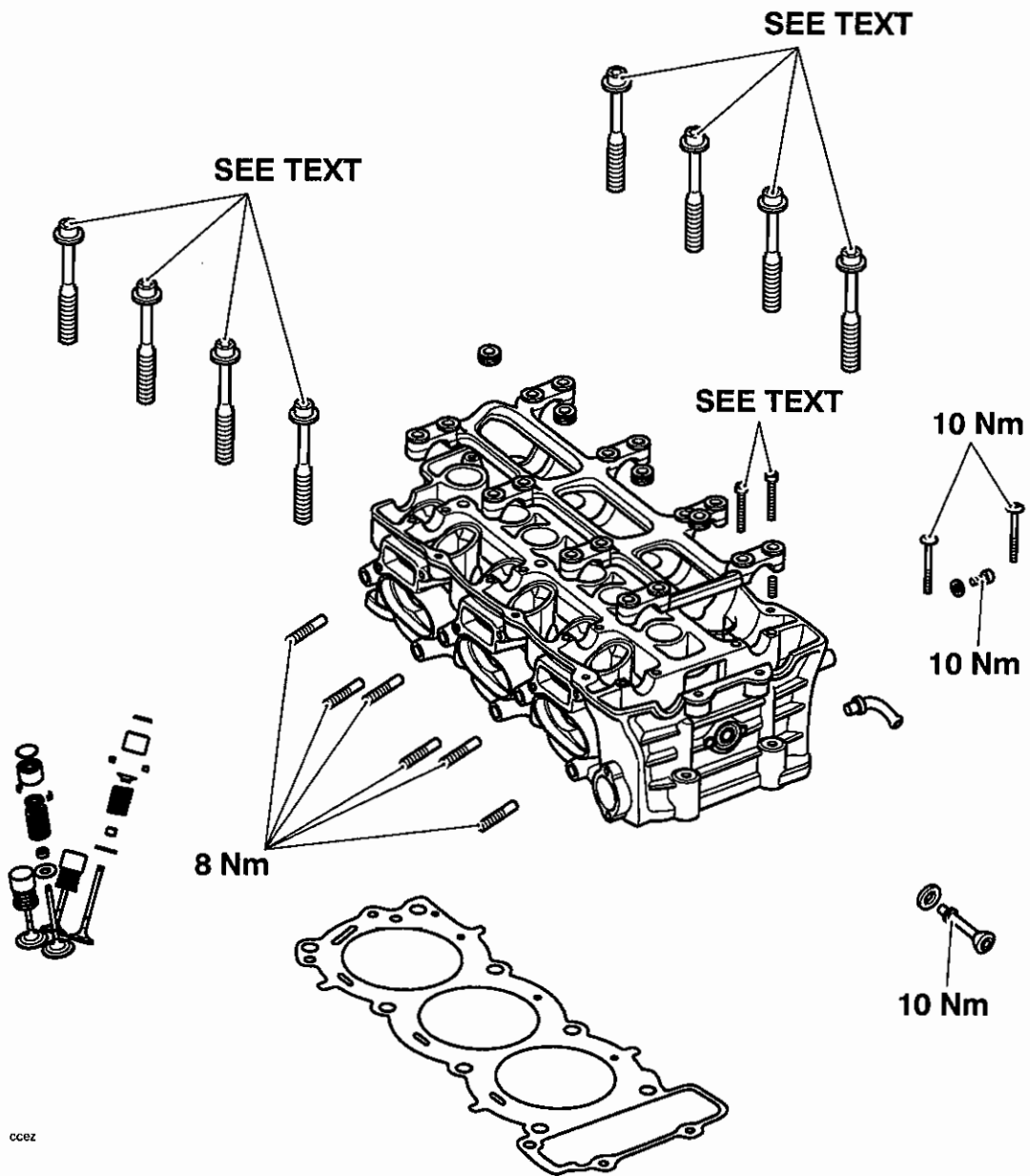

Description

The engine is fitted with an aluminum alloy cylinder head, which carries the camshafts, valves and spark plugs. The cylinder head is cast as a single entity, to which various components are permanently added after machining.

A silent-running cam chain drives the twin-overhead camshafts, which run directly in the cylinder head without additional bearings. The chain is tensioned by a spring-loaded device fitted to the cylinder head, and is guided by two Teflon-coated rubber-faced blades. Valve clearances are adjusted by changing variable thickness shims that sit between the camshaft and valve tappet bucket. The valves are fitted with single, symmetrical valve springs. Both the tip and seat face of the valves are hardened to give a long service life. Due to assembly methods used, the valve seats and valve guides cannot be replaced.

Oil is supplied to the cylinder head by an internal passageway inside the engine. Once it arrives at the cylinder head, it is passed through a restrictor, and is then delivered to the camshaft bearing journals along grooves in the cam ladder. The camshaft lobes are splash fed by oil coming from the camshaft journals.

Cam Cover

Warning

Before starting work, ensure the motorcycle is stabilised and adequately supported. This will help prevent it from falling and causing injury to the operator or damage to the motorcycle.

Removal

1. Remove the rider's seat (see page 17.9).
2. Disconnect the battery, negative (black) lead first.
3. Raise and prop the fuel tank (see page 11.98).
4. Remove the intake duct (see page 11.105) together with its bracket.
5. Disconnect the spark plug leads from the spark plugs then remove the coil brackets with the coils attached.
6. Remove the bungs from the heads of the cam cover fixings.

7. Release the bolts securing the cam cover to the head.

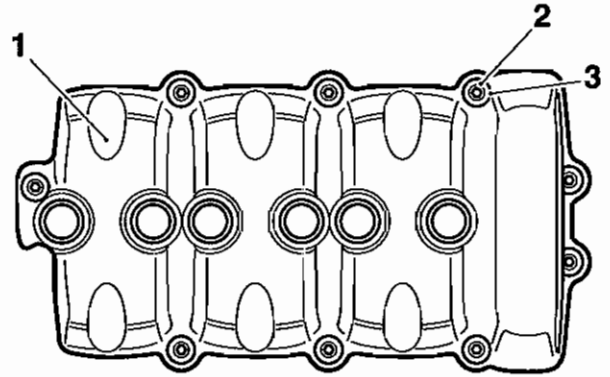

cbpo

1. Cam cover
2. Cam cover bolts
3. Bolt seals

8. Remove all the bolts and bolt-seals from the cam cover.
9. Raise the cover and manoeuvre it towards the right hand side of the engine, where it can be removed.

Caution

Never use a lever to remove the cam cover from the cylinder head. Using a lever will cause damage to the cylinder head and cam cover, which could lead to an oil leak.

10. Collect the seal from the head.

Cylinder Head

Installation

1. Check the condition of the cam cover seal and cam cover bolt seals. Replace as necessary.
2. Apply silicone sealant to the cylinder head where four 'D' sections of the cam cover seal fit.

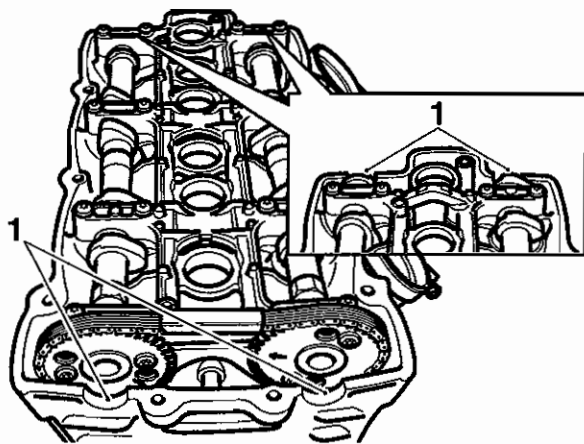

1. 'D' sections

3. Fit the seal ensuring the four 'D' sections seat in the corresponding half-rounds in the cylinder head. Position the spark plug tower seals to the six plug towers.
4. Fit the cam cover to the cylinder head. Ensure that the seal remains in position, paying particular attention to the six spark plug tower areas.
5. Fit the cam cover bolts, complete with their seals (steel ring side facing upwards) and tighten to finger tight.
6. Progressively and evenly tighten the cam cover bolts to **10 Nm**.
7. Refit the coil bracket and coils.
8. Reattach the plug leads to the plugs.
9. Refit the intake duct bracket, tightening its bolts to **9 Nm**.
10. Refit the intake duct (see page 11.109).
11. Seat the fuel tank on the frame and secure it (see page 11.99).
12. Reconnect the battery, positive (red) lead first.
13. Refit the rider's seat.

Cam Chain Tensioner

Warning

Before starting work, ensure the motorcycle is stabilised and adequately supported. This will help prevent it from falling and causing injury to the operator or damage to the motorcycle.

Removal

1. Remove the cam cover (see page 3.5).
2. Remove the inspection plug from the clutch cover.

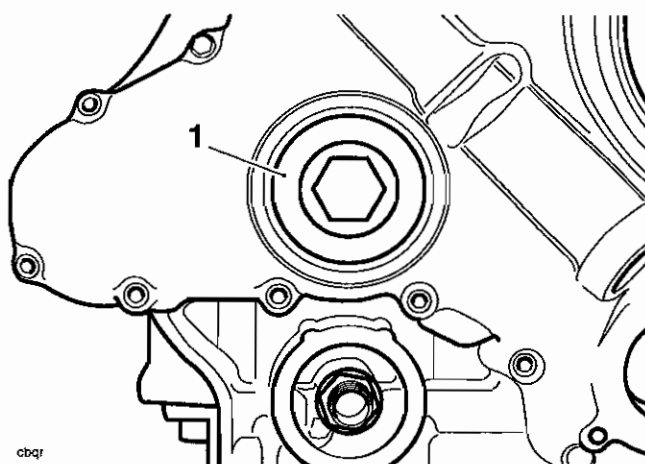

1. Inspection plug

3. Turn the engine until the maximum numbers of cam lobes are facing away from the valves. This will prevent the cams from springing around when the cam chain tensioner is removed.

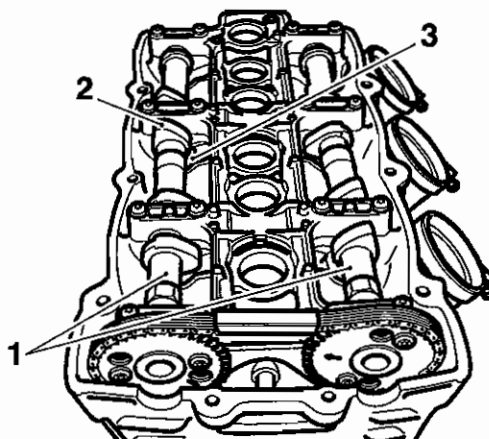

1. Camshafts

2. Lobes

3. Valves

4. Remove the center nut and washer from the cam chain tensioner.



The centre nut of the cam chain tensioner is under spring tension. Always wear hand, eye and facial protection when releasing the centre nut as unprotected areas of the body can be injured if the spring tension released in an unexpected or uncontrolled way.

5. Withdraw the spring and nut from the tensioner body.

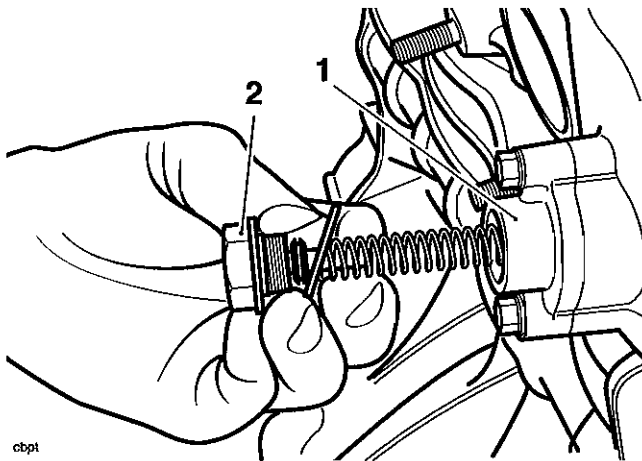

cbpt

1. Cam chain tensioner
2. Centre nut

6. Remove the cam chain tensioner body from the head.

Inspection

1. Inspect the tensioner spring for damage and deformation. Renew as necessary.
2. Inspect the tip of the tensioner plunger for wear and damage. Renew as necessary.

Installation

1. Fit a new gasket to the tensioner body.
2. Set the tensioner plunger onto the first tooth of the ratchet by manually lifting the tensioner pawl and pushing the plunger into the tensioner body.

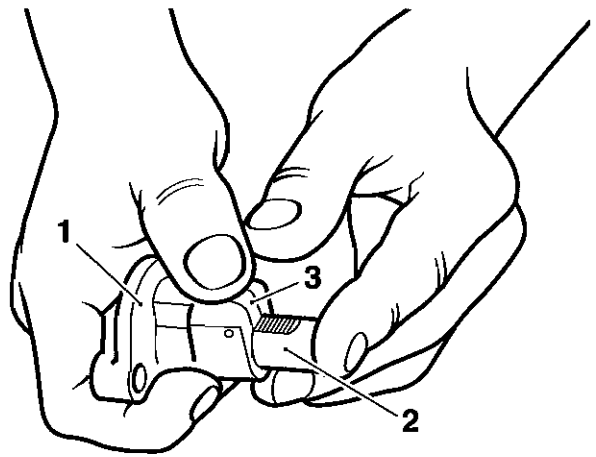

cbpu

1. Tensioner
2. Tensioner plunger
3. Pawl

3. Look into the inspection hole. Rotate the crankshaft clockwise (as viewed from the front), until No. 1 cylinder is at TDC. No. 1 cylinder is at TDC when a 'dot' mark on the crank gear is in alignment with the line in the upper crankcase.

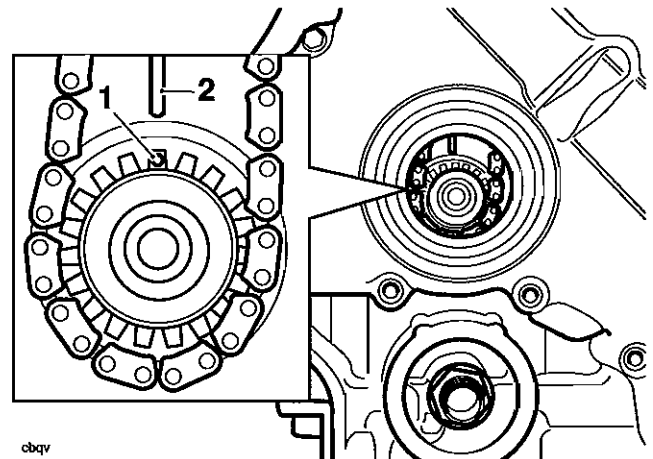

cbqv

1. Crankshaft 'dot' mark
2. Upper crankcase line

Cylinder Head

In addition, timing marks on the camshaft sprockets should point downwards at a point level with the cylinder head. If they do not align as shown, turn the camshafts until they do align.

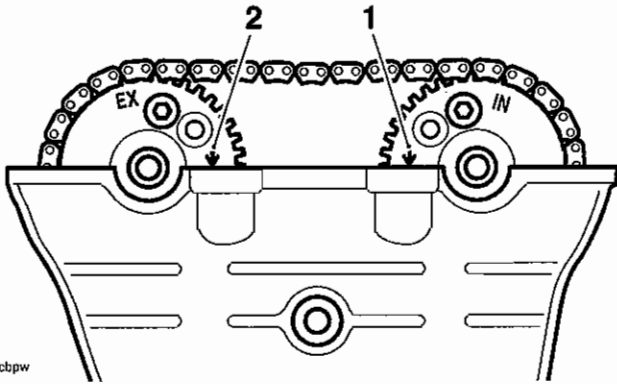

cbpw

1. Inlet cam timing marks
2. Exhaust cam timing marks

4. Fit the dowels of tool T3880202 to location holes in the cam sprockets, as shown in the diagram below. This will hold the cams in the correct timing position and prevent them from turning while the chain tensioner is fitted.

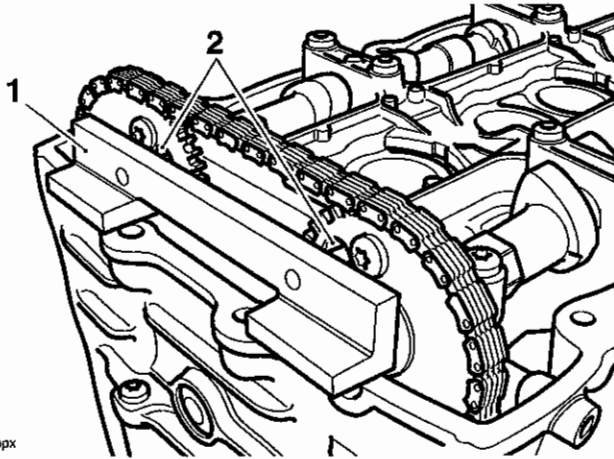

cbpx

1. Tool T3880202
2. Cam sprocket holes

5. Fit the tensioner to the crankcase (ratchet teeth facing upwards) ensuring the gasket is not damaged during the process.
6. Fit and tighten the tensioner fixings to **9 Nm**.

7. Push the tensioner plunger into contact with the chain guide using finger pressure.

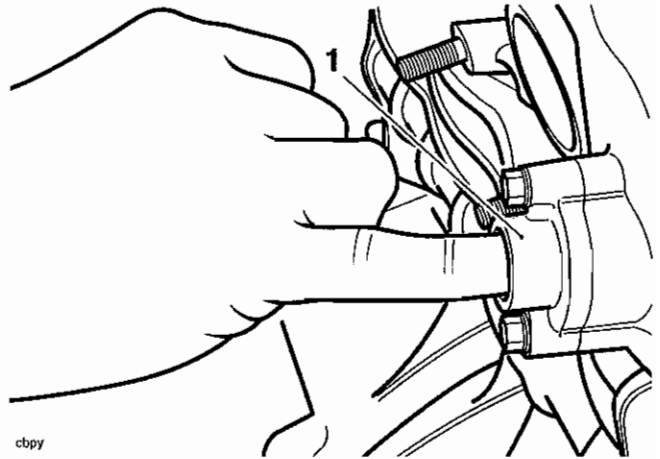

cbpy

1. Tensioner

8. Fit a new washer to the tensioner's centre nut.
9. Fit the spring to the tensioner body. Fit the centre nut and tighten to **23 Nm**.

Warning

The centre nut of the cam chain tensioner is under spring tension. Always wear hand, eye and facial protection when releasing the centre nut as unprotected areas of the body can be injured if the spring tension released in an unexpected or uncontrolled way.

10. Remove tool T3880202 and turn the crankshaft clockwise (as viewed from the front of the engine) through four complete revolutions. Stop when the timing marks on the crankshaft gear realign with the line in the upper crankcase.

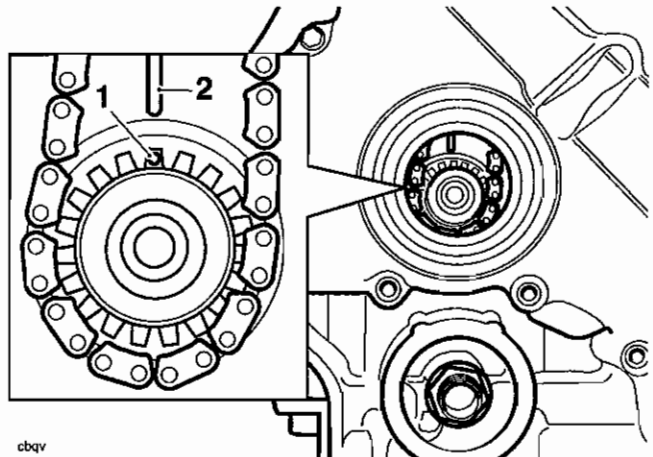

cbqv

1. Crankshaft 'dot' mark
2. Upper crankcase line

11. Check that the camshaft marks align as described previously. Rectify as necessary.

12. When the timing checks have been satisfactorily completed, refit the inspection plug tightening it to **18 Nm**.
13. Refit the cam cover (see page 3.6).

Camshafts

! Warning!
Before starting work, ensure the motorcycle is stabilised and adequately supported. This will help prevent it from falling and causing injury to the operator or damage to the motorcycle.

Note:

- Either camshaft can be removed from the cylinder head without complete removal of the cam chain. However, the cam chain must first be detached from the camshafts.

1. Remove the cam cover (see page 3.5).

Note:

- Turn the engine until the maximum number of cam lobes are facing away from the valves. This will prevent the cams from springing around when the cam chain tensioner is removed.

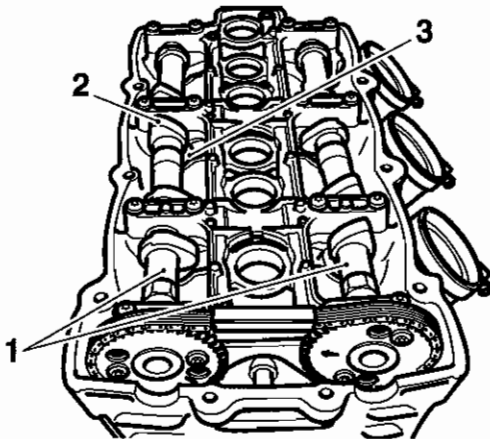

- cbps
1. Camshafts
 2. Lobes
 3. Valves

2. Remove the cam chain tensioner (see page 3.6).

3. Remove the cam chain top pad.

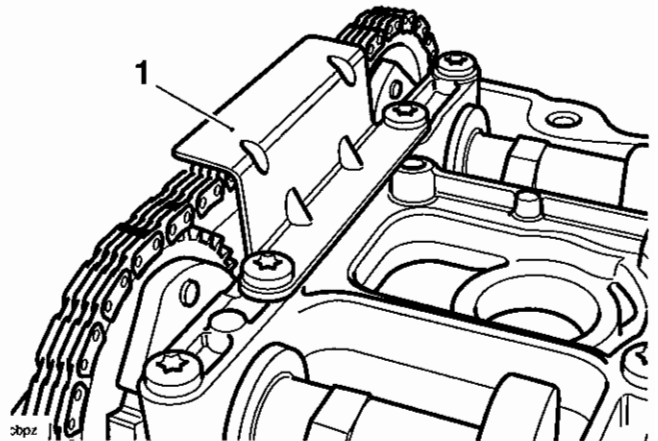

1. Top pad

! Caution
To avoid damage to the cam ladder, always ensure as many cam lobes as possible are facing away from the valves. This will reduce stress on the cam ladder during removal. Damage to the cam ladder will result in replacement of the complete head.

4. Progressively and evenly release the remaining cam ladder fixings, half a turn each, until the upward pressure on the bolt heads has been released. Always start from the centre of the engine.

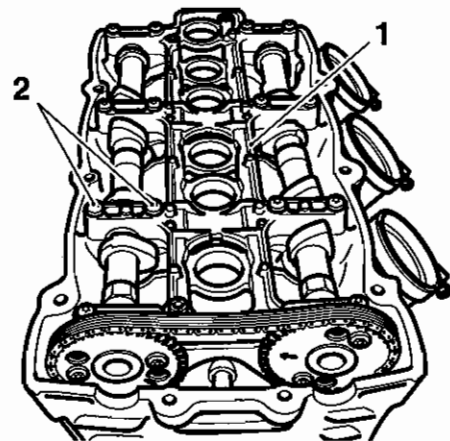

- cbqa
1. Cam ladder
 2. Cam ladder fixings (2 of 16)

Cylinder Head

⚠ Caution

Failure to release the cam ladder fixings progressively and evenly may result in damage to the cam ladder, the camshafts or the cylinder head itself. A damaged cam ladder cannot be replaced as an individual item. It can only be obtained as part of a new cylinder head.

5. Once all the upward force on the cam ladder has been progressively released, collect all the bolts and remove the ladder.
6. Secure the cam chain to prevent it from falling into the front of the engine.

Note:

- The sound suppression bolt will prevent the cam chain from falling completely away from the head.
7. Lift the cam chain from one of the camshafts to allow removal of the shaft from the cylinder head.

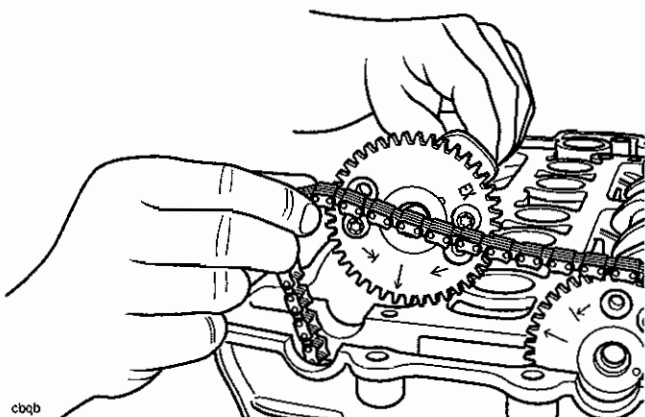

1. Removing a camshaft

8. Repeat for the second camshaft.

Camshaft identification

The inlet camshaft can be identified by a groove on a machined surface in its centre. The same surface on the exhaust cam is plain.

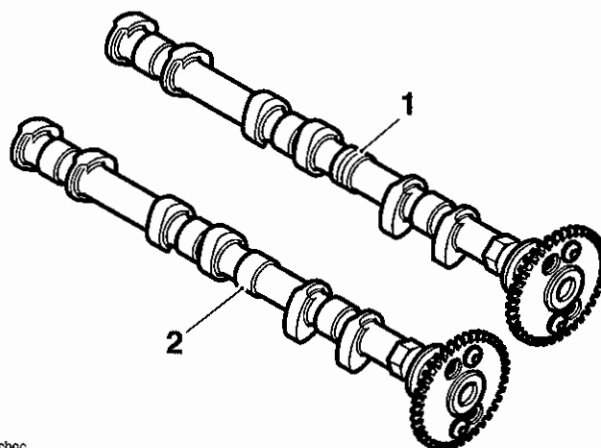

cbqc

1. Inlet cam (grooved)
2. Exhaust cam (plain)

Cam sprocket orientation

The same drive sprocket is used for both inlet and exhaust cams.

To attach the sprocket in the correct relationship to the cams, two pairs of offset bolt holes are used, with inlet and exhaust bolt holes being clearly marked ('IN' for inlet and 'EX' for exhaust). The holes will also prevent the sprockets from being fitted 180° out of alignment.

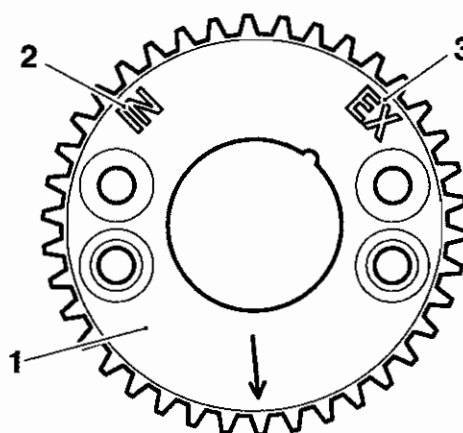

cbqd

1. Sprocket
2. IN marking
3. EX marking

To fit a sprocket to an **inlet** cam, position the sprocket to the cam and align the hole marked 'IN' with one of the threaded holes in the camshaft. If both bolt-holes in the cam line up correctly with the holes in the sprocket, the sprocket is in the correct place. If the holes do not line up, then the sprocket should be rotated by a half-turn.

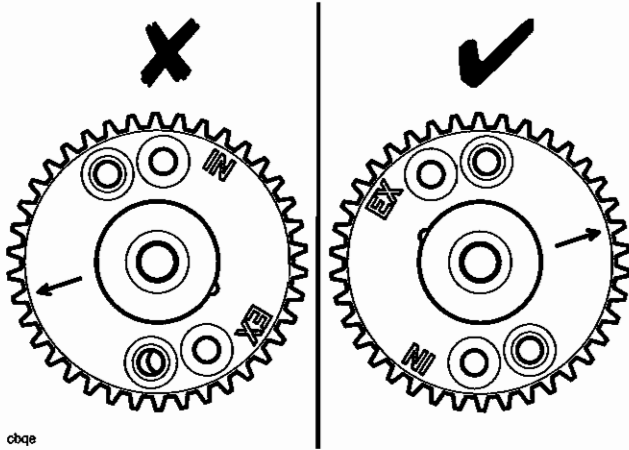

cbqe

Inspection

1. Inspect the sprockets for damage and worn or broken teeth.
2. Inspect the bearing surfaces in the cylinder head and cam ladder. If wear or damage is found, the cylinder head must be replaced.
3. Inspect the cam chain (see page 3.7).
4. Check camshaft journal to cam ladder clearance using Plastigage (Triumph part number 3880150-T0301) as follows:



Caution

During the flowing procedure, the engine must not be rotated. Damage to valves, pistons and the cylinder head can result from rotating the engine.

- a) Position a camshaft to the cylinder head in its correct location, (inlet cam to inlet valves, exhaust cam to exhaust valves). Ensure that the timing marks on the cam sprocket are positioned as for removal.
- b) Release and remove the cam ladder as previously described. Wipe the exposed areas of one of the camshaft journals and the corresponding position on the cam ladder.
- c) Apply a thin smear of grease to the wiped camshaft journal and a small quantity of silicone release agent to the corresponding position on the cam ladder.
- d) Size a piece of Plastigage to fit across the wiped camshaft journal.
- e) Fit the Plastigage to the camshaft journal using the grease to hold it in place.
- f) Position the cam ladder to the cylinder head, aligning bearing areas with cam journals. At this stage, it is not necessary to fit the cam chain top pad.

- g) Finger-tighten the cam ladder bolts until the under-head areas are in contact with the cam ladder.
- h) In the sequence shown below evenly and progressively tighten the cam ladder bolts, approximately half a turn each, until the cam ladder is in full contact with the head.

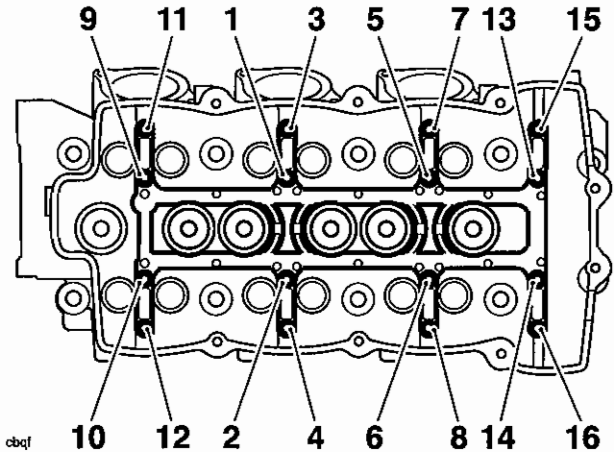

cbqf

1. Cam ladder tightening sequence

- i) In the same sequence, torque each cam ladder bolt to 10 Nm.
- j) Release and remove the cam ladder as previously described.
- k) Utilising the gauge provided with the Plastigage kit, measure the width of the now compressed Plastigage.

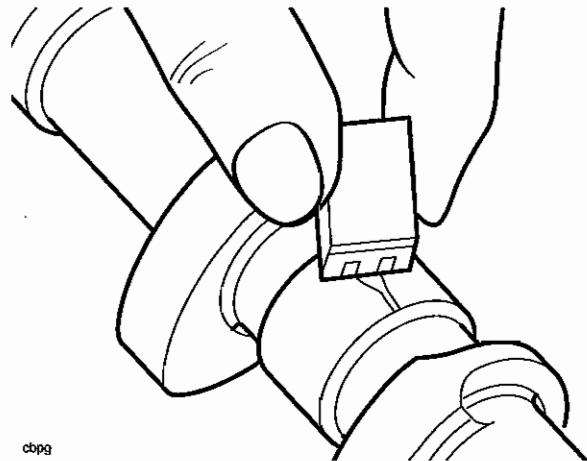

cbpg

1. Taking a plastigage measurement

5. Calculate the cam journal clearance using the chart provided with the Plastigage kit.

Cylinder Head

- If the journal to cam ladder clearance is within the specified tolerances (see table below), remove the cam ladder and clean off all traces of Plastigage, silicone release agent and grease.

| | |
|---------------|------------------|
| Standard | 0.040 - 0.091 mm |
| Service limit | 0.13 mm |

- Check the diameter of the camshaft journals.

| | |
|----------|------------------|
| Standard | 22,93 – 22.96 mm |
|----------|------------------|

- If any of the journal to cam ladder clearances are outside the specified tolerances, but the camshaft journals are within their specified tolerances, the cylinder head must be replaced.

Installation

- Correctly identify the inlet and exhaust cams as previously described.
- Position the camshafts to the two banks of valves ensuring that the inlet cam is located to the inlet valves and the exhaust cam to the exhaust valves.
- Turn the engine over so that all three pistons are away from TDC (approximately 15°ATDC).

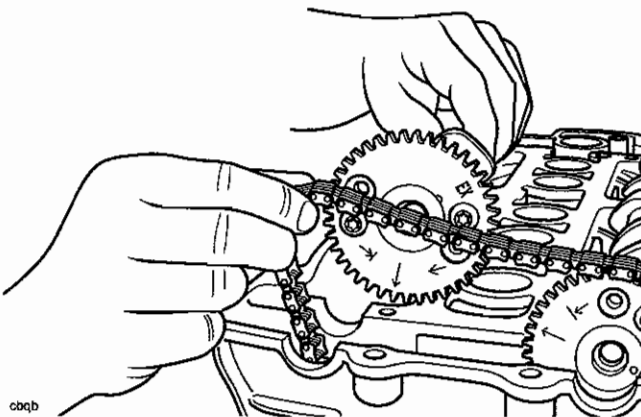

- Working on one cam at a time, locate the cam chain over the camshaft sprockets.
- Ease the cam chain away from the sprockets then turn each camshaft until as many lobes as possible are facing away from the valves. Allow the chain to drop back onto the cams.

Caution

To avoid damage to the cam ladder, always ensure as many cam lobes as possible are facing away from the valves. This will reduce stress on the cam ladder during assembly. Damage to the cam ladder will result in replacement of the complete head.

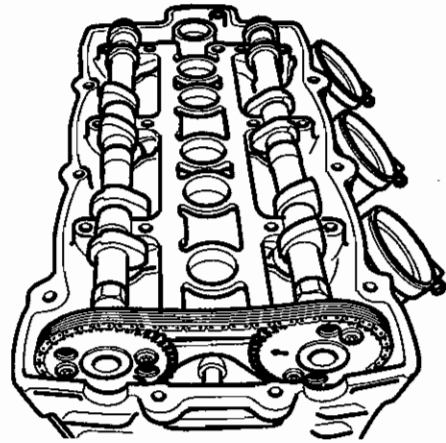

cbqw

Located camshafts

- Lubricate the cam bearing areas of the cam ladder with a 50/50 solution of engine oil and molybdenum disulphide grease.

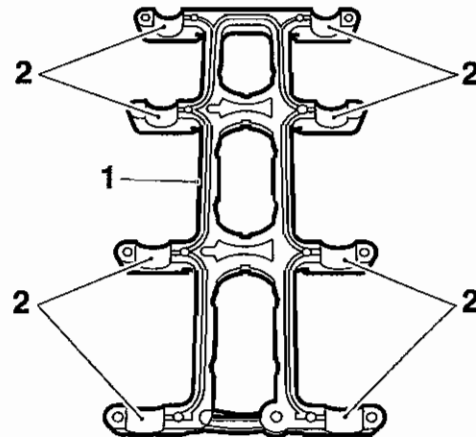

cbqh

- Cam ladder
 - Cam bearing areas
- Lubricate the threads of the cam ladder bolts with clean engine oil.
 - Position the cam ladder to the cylinder head, aligning bearing areas with cam journals.
 - Finger-tighten the cam ladder bolts until the bolt's under-head areas are in contact with the cam ladder.

10. In the sequence shown below evenly and progressively tighten the cam ladder bolts, approximately half a turn each, until the cam ladder is in full contact with the head.

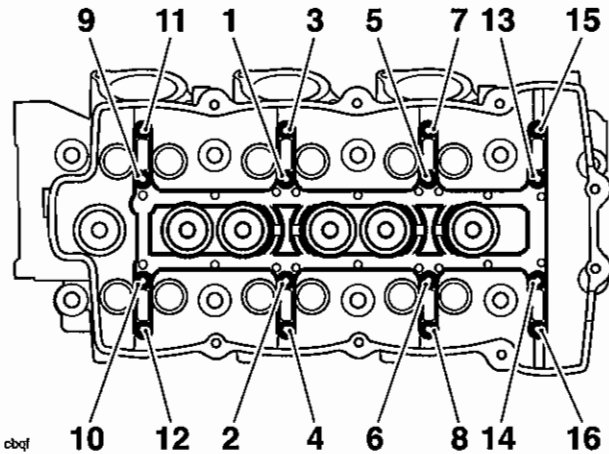

cbqf

1. Cam ladder tightening sequence

11. In the same sequence, torque each cam ladder bolt to **10 Nm**.
12. Fit the cam chain top pad. Tighten the top pad fixings to **10 Nm**.
13. Ease the cam chain away from the cams. Rotate the crankshaft clockwise (as viewed from the front), until No. 1 cylinder is at TDC. No. 1 cylinder is at TDC when a 'dot' mark on the crank gear is in alignment with the line in the upper crankcase.

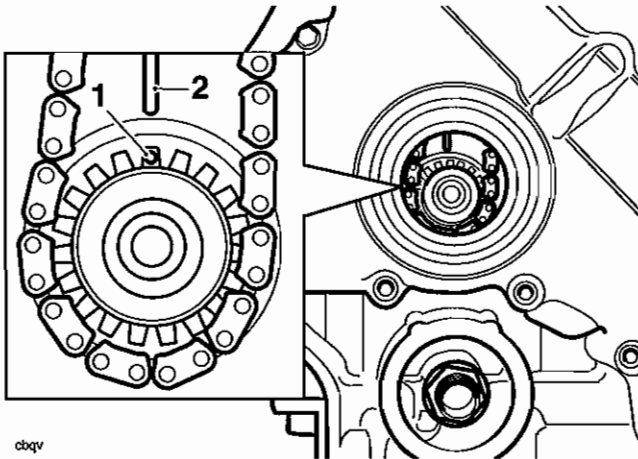

cbqv

1. Crankshaft 'dot' mark
2. Upper crankcase line

Note:

- After placing each cam in the timing position, it will be necessary to have an assistant hold the cams in position until tool T3880202 is fitted.
- Set the exhaust cam first, then the inlet.

14. Ease the cam chain away from the sprockets and position the cams so that the timing marks align as shown below. Allow the cam chain to drop back onto each sprocket after positioning each cam.

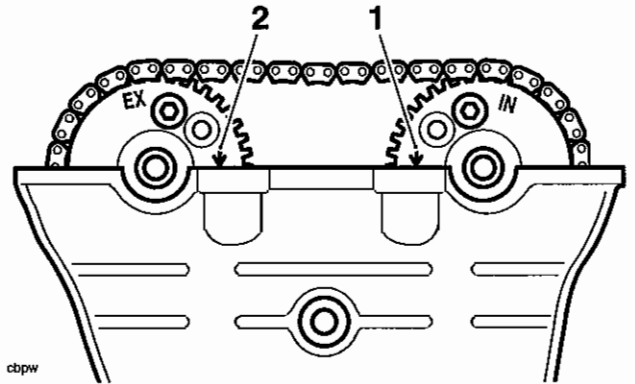

cbpw

1. Inlet timing mark
2. Exhaust timing mark

15. Fit tool T3880202 to location holes in the cam sprockets as shown in the diagram below. This will hold the cams in the correct timing position and prevent them from turning while the chain tensioner is fitted.

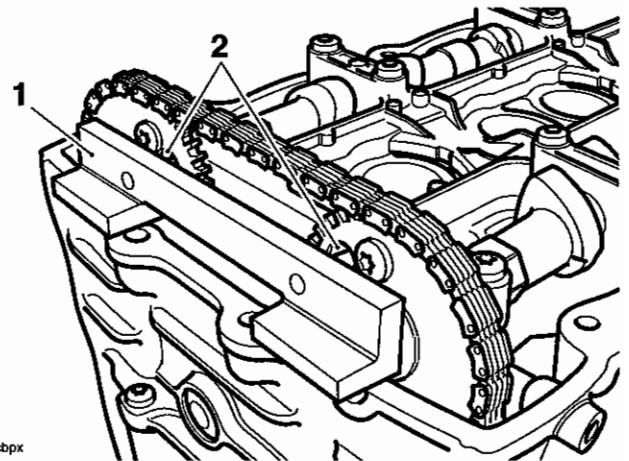

cbpx

1. Tool T3880202
2. Cam sprocket holes

16. Refit and assemble the cam chain tensioner plunger, spring and centre nut (see page 3.7).
17. Remove tool T3880202.
18. Turn the engine over at least four times, then check the cam timing again. Reset as necessary.
19. Check all valve clearances (see page 3.14). Adjust as necessary to give the correct clearances.
20. Refit the cam cover (see page 3.6).

Cylinder Head

Valve Clearances

Camshaft, valve, valve shim and valve seat wear affect the valve clearances. The effect of this wear is to change the clearance between the camshaft and the adjustment shim, causing engine noise and/or improper running. If the valve clearances are incorrect, permanent damage to components in the valve-train will take place and engine performance will be affected.

Correct valve clearances are in the range given in the table below.

| | |
|---------|-----------------|
| Inlet | 0.10 to 0.15 mm |
| Exhaust | 0.15 to 0.20 mm |

Note:

- **Valve clearance adjustment must be carried out with the engine cold.**

1. Remove the cam cover (see page 3.5).
2. Remove a spark plug from each cylinder to reduce compression resistance when turning the engine.
3. Select a high gear and, using the rear wheel, turn the engine over until a pair of camshaft lobes are positioned pointing directly away from the valves.
4. Using feeler gauges, measure and record the clearances for this pair of valves only.
5. Repeat the process until the clearances for all valves have been checked.

If any of the recorded clearances fall outside the specified range, adjustments must be made. If all measured clearances are within tolerance, refit the cam cover (see page 3.6).

Valve Clearance Adjustment

Note:

- **Valve clearance checking and adjustment must be carried out with the engine cold.**

1. Measure and record all valve clearances as described previously.
2. Remove the camshafts (see page 3.9).
3. Remove a shim from one of the valves whose clearance required adjustment.
4. Measure the original shim, using a micrometer.
5. Calculate the shim thickness required to give the correct clearance. Clearance too small; fit a thinner shim. Clearance too large; fit a thicker shim.

Note:

- **Shims are available ranging from 2.00 mm to 3.20 mm in increments of 0.025 mm.**
6. Fit the selected shim to the tappet bucket.
 7. Repeat the procedure until all valves requiring adjustment have been correctly set.
 8. Refit the camshafts (see page 3.12).
 9. Rotate the engine several times to fully seat the shims.
 10. Repeat the clearance checks on all valves, adjust as necessary.
 11. Refit the cam cover (see page 3.6).

Cylinder Head

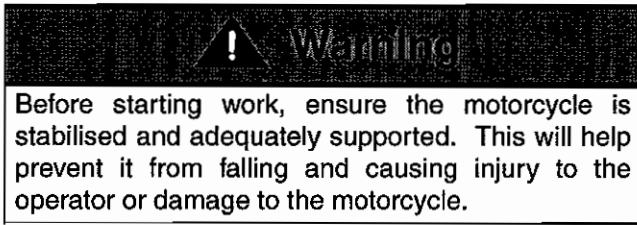

1. Remove the fuel tank (see page 11.100).
2. Drain the cooling system (see page 12.6).
3. Remove the exhaust header system (see page 11.134).
4. Remove the throttle bodies (see page 11.122).
5. Remove the oil tank (see page 9.16).
6. Remove the camshafts (see page 3.9).
7. Disconnect the top and bypass hoses from the cylinder head.

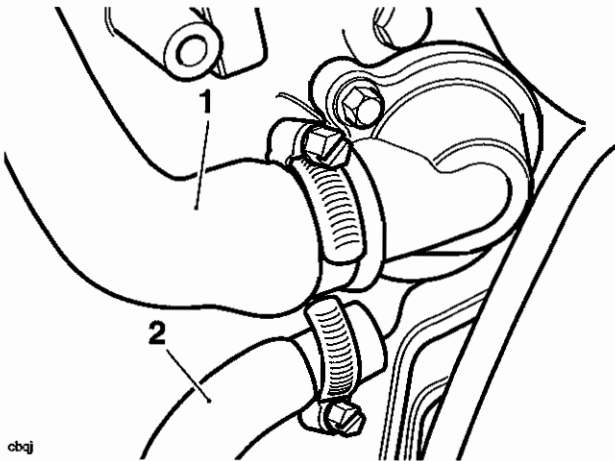

1. Top hose
2. Bypass hose

8. Disconnect the coolant temperature sensor and low oil pressure switch connections.

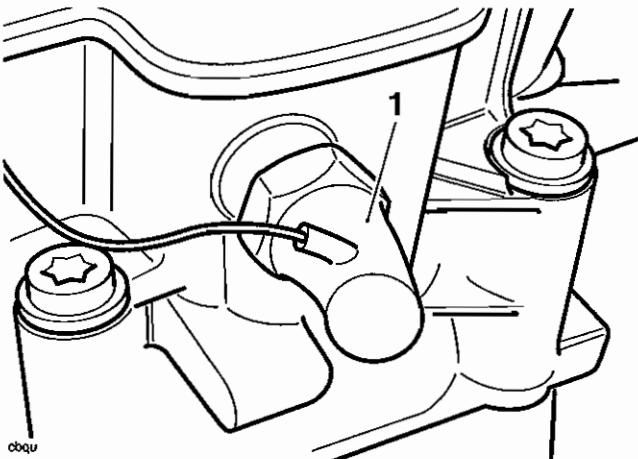

1. Low oil pressure warning light switch

9. Remove both engine in-fill panels.

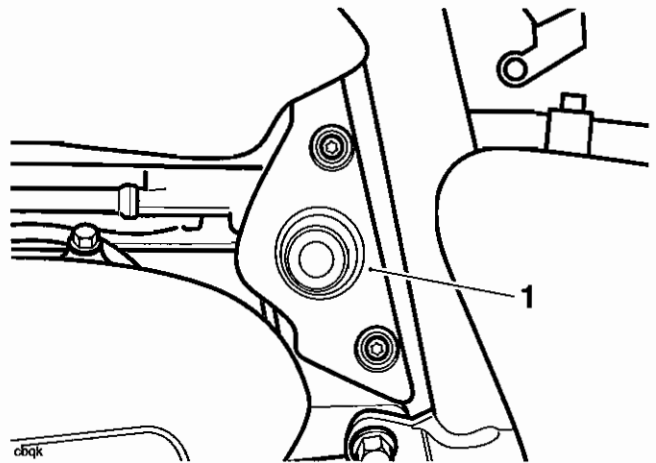

In-fill panel

10. Identify the position of each of the tappet buckets and shims before removing them from the head.
11. Remove the sound suppression bolt from the cam chain chest.
12. Progressively release the cylinder head bolts in the order shown below.

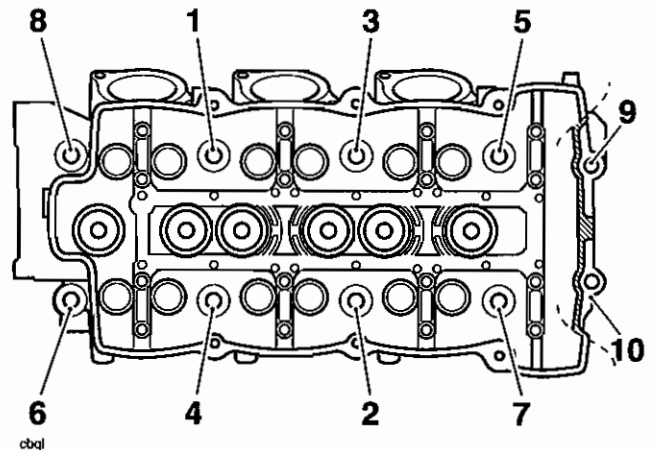

Head bolt release sequence

13. Remove the head bolts including two smaller bolts situated at the front of the engine.
14. Remove the head from the crankcase.

Note:

- If necessary, lightly tap the head with a soft-faced mallet to break the gasket seal.

15. Remove and discard the head gasket.

16. Remove the cylinder liners (see page 5.18).

Note:

- Cylinder liners must be resealed if the head is removed.

Cylinder Head

Inspection

1. Thoroughly clean the surface of the cylinder head and check for damage and/or pitting of the combustion chambers.
2. Using a straight edge and feeler gauges, check the cylinder head gasket face for warp, which could lead to gasket failure. Replace the cylinder head if warped beyond the flatness limit.

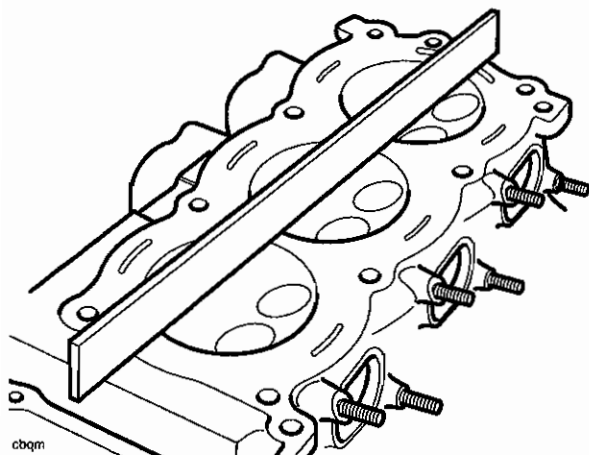

Checking head flatness

| | |
|----------------------------------|----------|
| Cylinder head flatness tolerance | 0.030 mm |
|----------------------------------|----------|

3. Check the cam chain rubbing blades. Renew if worn or damaged.



Caution

Ensure all traces of fluid (coolant, oil etc.) are removed from the threaded holes in the crankcase. Should any fluid remain in any of the threaded holes, severe crankcase damage could result from hydraulic locking of head bolts on assembly of the engine.

Installation

1. Thoroughly clean the upper faces of the crankcase and liners. Also clean the liner to crankcase mating faces.
2. Fit the cylinder liners (see page 5.19).
3. Move the cam chain rubbing blades to a position that allows the head to fit over them.
4. Ensure that both head dowels remain in position in the crankcase.

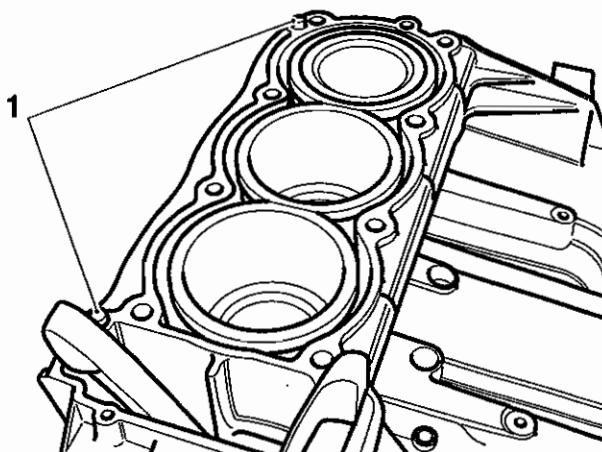

1. Dowels

5. Position a new cylinder head gasket to the crankcase.
6. Lower the cylinder head over the cam chain rubbing blades and locate it onto the dowels.



Caution

Cylinder head bolts must never be reused and must always be replaced if removed or loosened.

Use the correct procedure to tighten the cylinder head bolts carefully following the three-stage procedure below. This will ensure the long-term reliability of the cylinder head gasket.

Failure to follow the correct tightening procedure or reuse of old head bolts may lead to engine damage and premature failure of the cylinder head gasket.

7. In the order shown below, tighten the cylinder head bolts in three stages as follows:

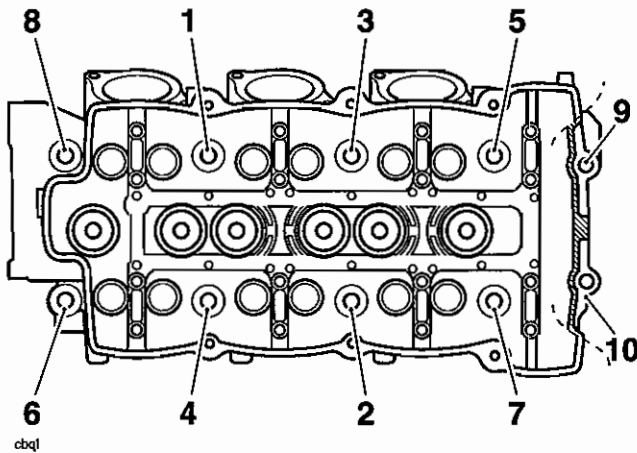

Cylinder head bolt tightening sequence

8. In the sequence shown above, tighten bolts 1 through 8 to **20 Nm**.
9. In the sequence shown above, tighten bolts 1 through 8 to **50 Nm**.
10. In the sequence shown above, tighten bolts 1 through 8 through a further 90° using tool T3880105 or similar to measure the torque-angle.
11. Tighten bolts 9 and 10 to **12 Nm**.
12. Lubricate the tappet buckets with a 50/50 solution of molybdenum disulphide grease and engine oil, then refit them and the valve shims to their original locations in the head.
13. Refit the camshafts (see page 3.12).
14. Check and adjust the valve clearances (see page 3.14).
15. Reconnect the coolant temperature sensor.
16. Refit the bypass and top hoses.
17. Refit the oil tank (see page 9.16).
18. Refit the throttle bodies (see page 11.123).
19. Refit the exhaust system (see page 11.136).
20. Refill the cooling system (see page 12.7).
21. Refit the fuel tank (see page 11.101).
22. Refit both engine in-fill panels, tightening the fixings to **4 Nm**.
23. Start the engine and allow it to idle while checking for air, oil, coolant and exhaust leaks. Rectify as necessary.
24. Check and top up the cooling system (see page 12.5).
25. Check and top up the oil level (see page 9.7).

Valves and Valve Stem Seals

Removal from the cylinder head

1. Remove each valve from the head using a valve spring compressor. The compressor must act on the top cup to allow removal of the valve collets.
2. Once the collets are released, remove the following items:
 - collets
 - valve spring cap
 - valve spring
 - valve stem seal
 - valve spring thrust washer

Installation

1. Apply a thin coat of molybdenum disulphide grease to the valve stem.
2. Install the valve into the valve guide and refit the thrust washer to the valve spring recess (if removed).
3. Fit the valve stem seal over the valve stem and, using a suitable tool, press down fully until the seal is correctly seated over the valve guide.

Note:

- **During fitment of the valve stem seal, two distinctly different degrees of resistance will be noted when the seal is correctly fitted.**
4. Firstly, press the seal down the valve stem until the lower side of the seal comes into contact with the valve guide. Greater resistance is felt at this contact point and further gentle pressure is then required to locate the seal over the top end of the valve guide.
 5. On application of this pressure, the seal can be felt to positively locate over the top face of the valve guide. Once correctly positioned, the seal cannot be pushed down any further.

Caution

Incorrect fitment of the valve stem oil seals could lead to high oil consumption and blue smoke emissions from the exhaust system. Do not use excessive force in fitting the seal as this may break the seal ring.

6. Install the valve spring.

Cylinder Head

7. Compress the valve spring ensuring that the spring is compressed squarely to prevent damage to components.
8. Fit the valve collets ensuring their correct location in the spring cap and valve as the spring compressor is released.



Caution

Always check for correct location of the valve collets during and after assembly. If not fitted correctly, the collets may become dislodged when the engine is running allowing the valves to contact the pistons. Any such valve to piston contact will cause severe engine damage.

Cam Chain

Inspection

An in-situ check can be made as follows:

1. Check for significant blue discolouration of the chain plates indicating excessive heat build-up.
2. Examine all pins for signs of rotation.
3. Check for cracking or deep scratching of the chain plates.
4. Check for severe wear of the inner plates as indicated in the diagram below.

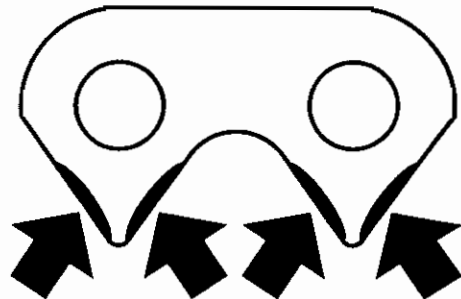

cbqo

For a more thorough check, proceed as follows:

1. Remove the chain from the engine.
2. Suspend the chain from a pin or hook with a 13kg weight attached at the lower end.



cbqo

3. Measure across 23 links as shown in the diagram. If the chain is within limits, the measurement should be no longer than 147.63 mm. Measurements beyond 147.63 mm indicate that the chain must be replaced.

6. Check for severe wear of the plates in the area shown below.

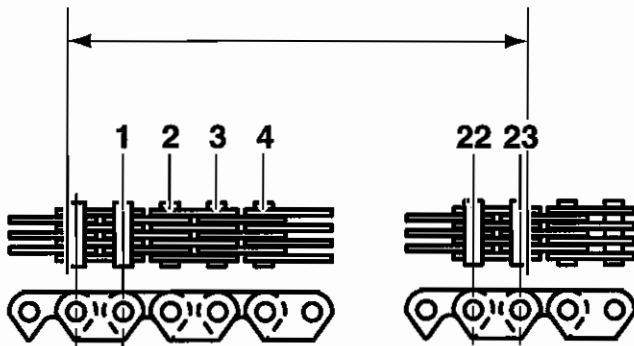

cbqg

4. Check for severe wear of the inner surface of the outer plates at the side-contact points with the sprocket teeth.

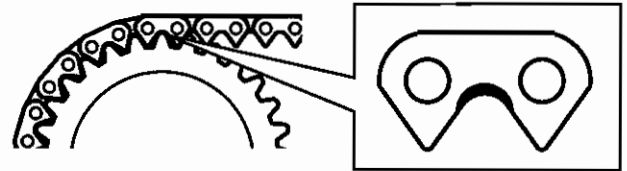

cbqv

If any of these symptoms are evident, the cam chain must be replaced.

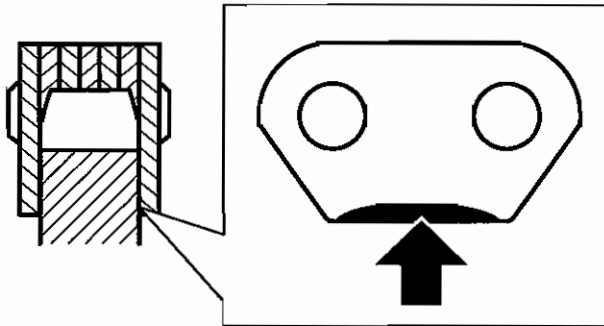

cbqr

5. Check for signs of stiffness or kinking.

This page intentionally left blank

4 Clutch

Table of Contents

| | |
|---------------------------------------|-----|
| Exploded View - Clutch Controls | 4.2 |
| Exploded View - Clutch | 4.3 |
| Exploded View - Clutch Cover | 4.4 |
| Clutch Cable | 4.5 |
| Removal | 4.5 |
| Examination | 4.6 |
| Installation | 4.6 |
| Clutch Cover | 4.7 |
| Removal | 4.7 |
| Installation | 4.7 |
| Clutch | 4.7 |
| Removal | 4.7 |
| Friction Plate Inspection | 4.9 |
| Thickness | 4.9 |
| Assembly | 4.9 |

Exploded View - Clutch

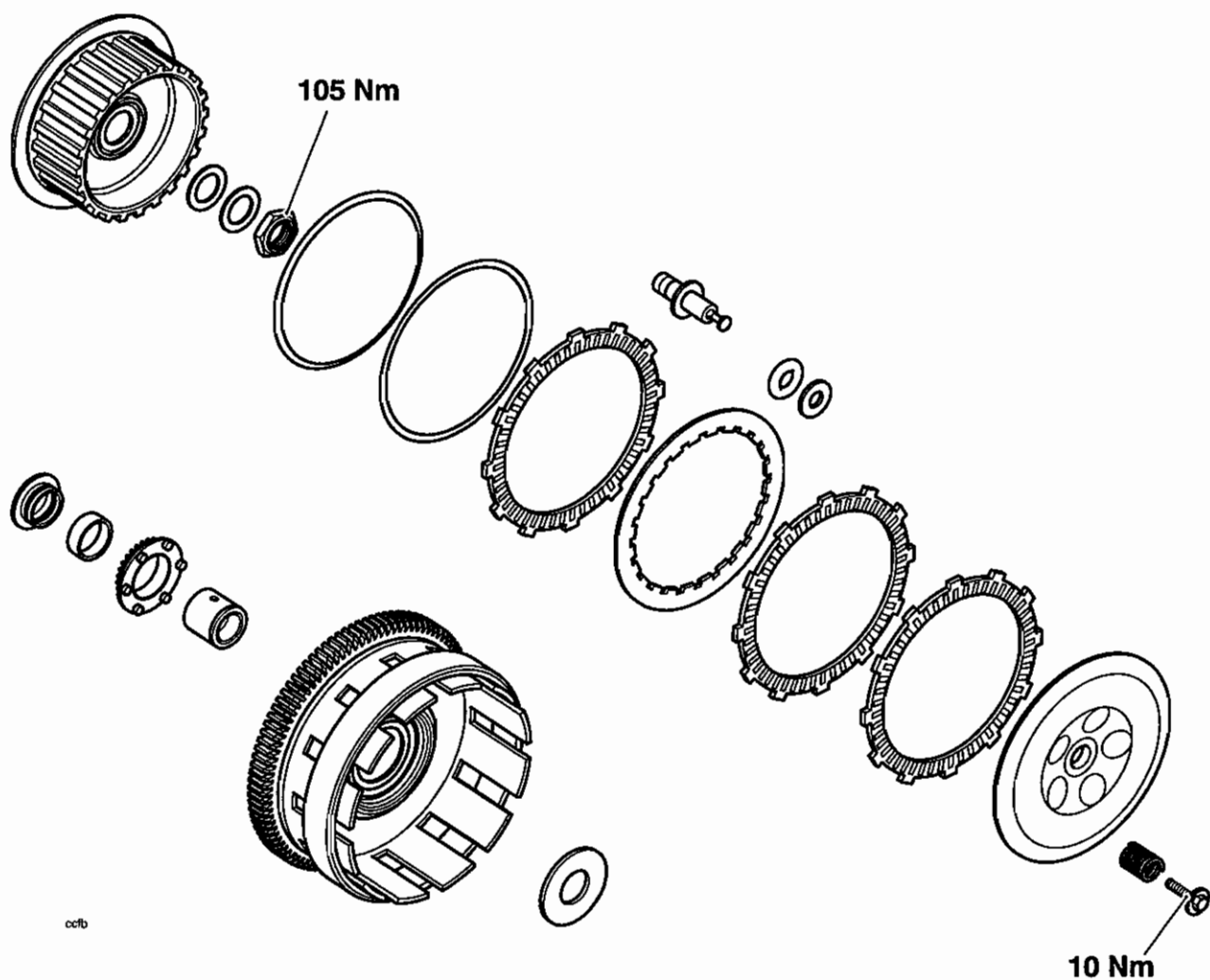

Clutch

Exploded View - Clutch Cover

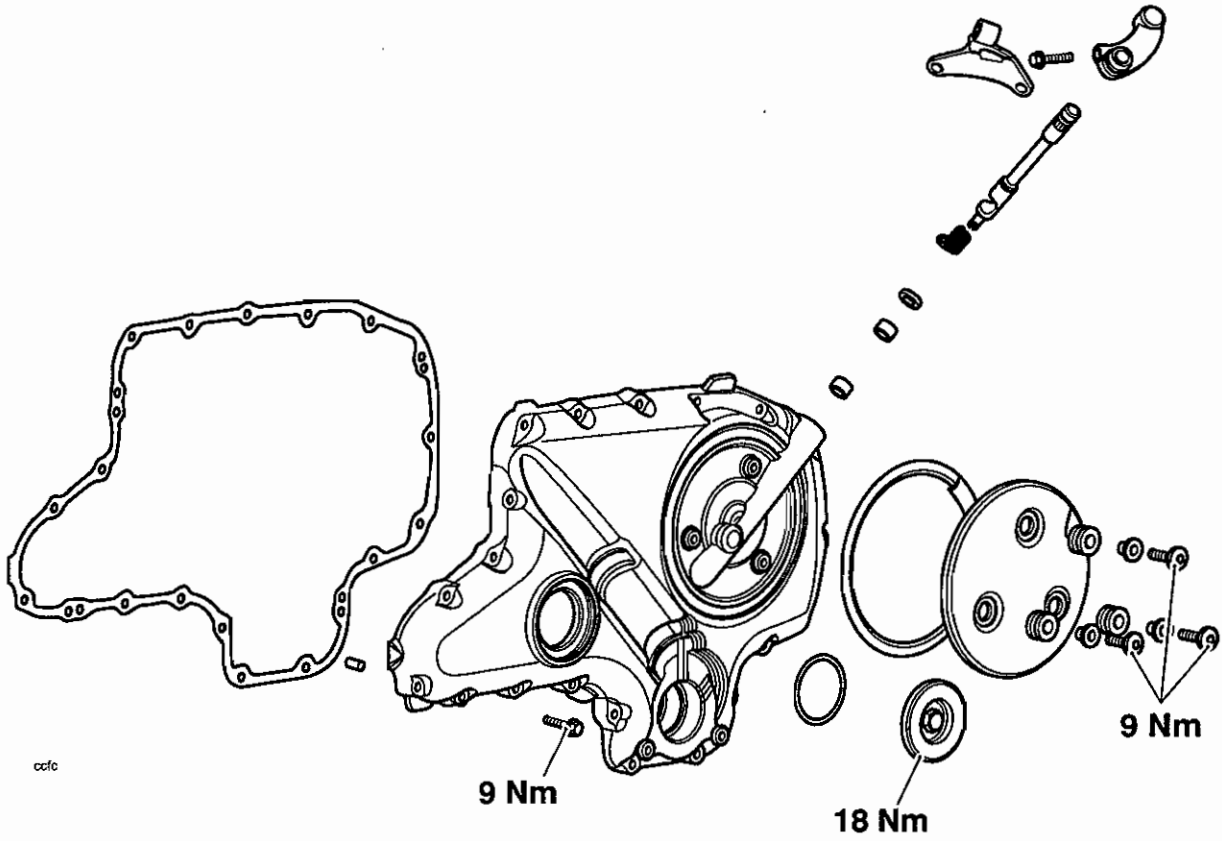

Clutch Cable

Removal

! Before starting work, ensure the motorcycle is stabilised and adequately supported. This will help prevent it from falling and causing injury to the operator or damage to the motorcycle.

1. Remove the rider's seat as described on page 17.9.
2. Disconnect the battery, negative (black) lead first.
3. Slacken the cable locknut and release the adjuster at the engine end to give maximum play in the cable.

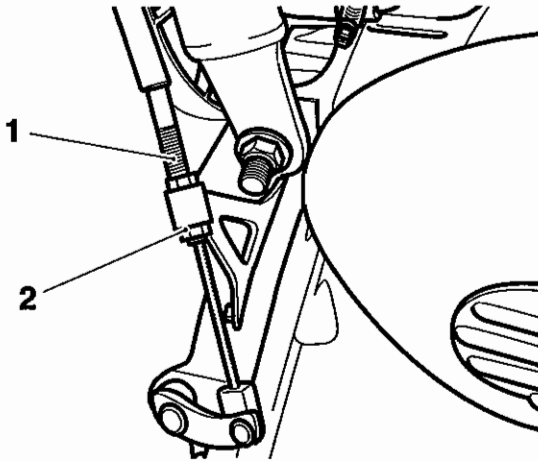

cbwn

1. Clutch Cable
2. Adjuster

4. Release the clutch cable from the actuating arm by pushing the inner cable nipple through the arm and sliding the cable out. Detach the cable from the bracket.

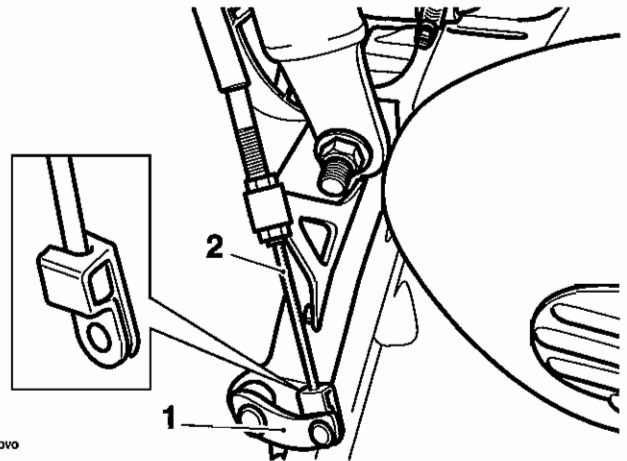

cbvo

1. Actuating Arm
2. Inner Cable

5. Align the slots in the lever adjuster and locknut.

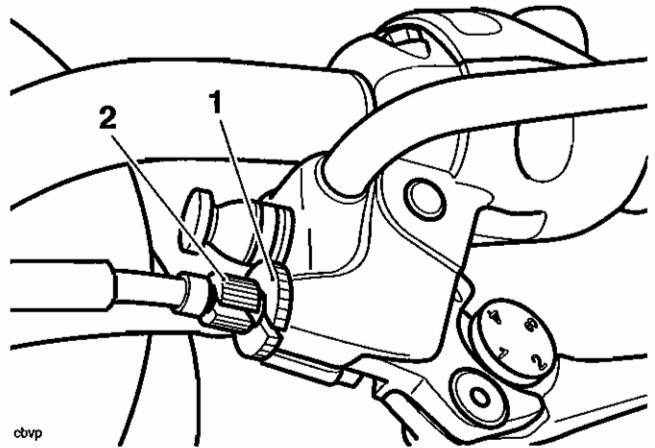

cbvp

1. Locknut
2. Lever adjuster

Clutch

6. Pull in the clutch lever and turn the inner cable, anti-clockwise through the slots in the adjuster and locknut, until the cable can be detached from the lever.

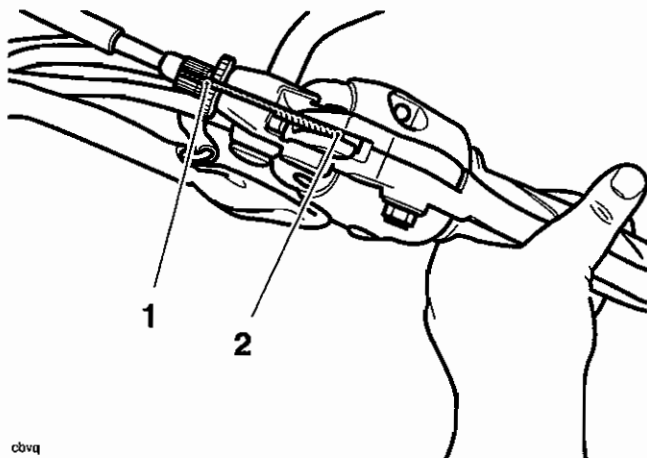

1. Nut/locknut Slots
2. Cable Release Point

7. Remove the cable from the motorcycle noting the cable routing, particularly where it passes through steering area.

Note:

- To ensure the same route can be followed on installation, tie a length of string to one end while pulling the cable through from the other. When installing the new cable, tie the string to one end of the cable and use it to guide the new cable into position.

Examination

1. Check the inner cable for free movement through the outer cable.
2. Examine the inner cable for frayed strands.
3. Examine the two inner cable nipples for signs of looseness and damage. Replace the cable if necessary.

Installation

1. Position the cable to the motorcycle following the same routing as noted during removal.
2. Attach the inner cable to the clutch lever and actuating arm using a reversal of the removal process.
3. Refit the outer cable to the adjuster bracket at the engine end.

Note:

- Ensure that the two adjuster nuts are positioned, one either side of the bracket.
4. Set the lever adjuster to a point where an equal adjustment is possible in both directions.
 5. Set the adjuster at the clutch end to give a preliminary setting of 2-3 mm of free play as measured at the lever.
 6. Operate the clutch lever several times and recheck the amount of free-play present.
 7. Set the final adjustment of the cable to give 2-3 mm of free-play at the lever by turning the adjuster nut and locknut at the lever end. Secure the setting with the knurled locknut.

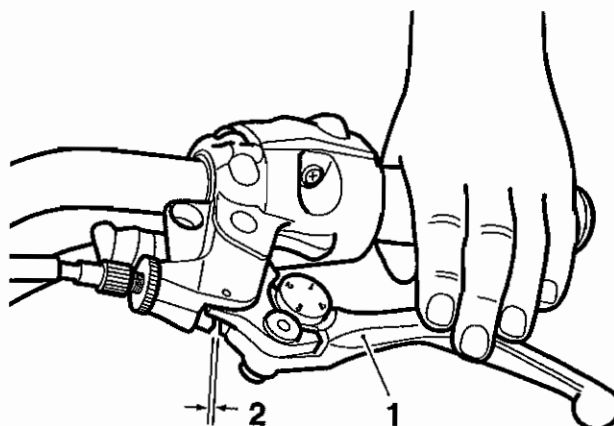

1. Clutch Lever
2. Correct Setting, 2-3 mm

8. Reconnect the battery positive (red) lead first.
9. Refit the rider's seat.

Clutch Cover

Removal

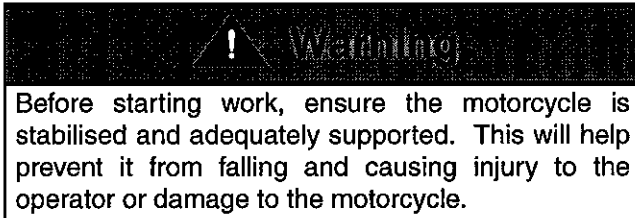

Before starting work, ensure the motorcycle is stabilised and adequately supported. This will help prevent it from falling and causing injury to the operator or damage to the motorcycle.

1. Remove the radiator as described on page 12.11.
2. Remove the water pump as described on page 12.7.
3. Remove the coolant pipe running between the crankcase and water pump.
4. Disconnect the clutch cable as described on page 4.5.
5. Release the ring of bolts securing the clutch cover to the crankcases.
6. Place an oil catch tray beneath the clutch cover to collect any oil that may spill out on removal.
7. Carefully withdraw the cover disengaging the lifter arm as it is eased forward.

Installation

1. Thoroughly clean the cover and crankcase mating faces.
2. Position a new gasket to the crankcase.
3. Refit the cover ensuring that the gasket does not become dislodged.

Note:

- **Ensure that the lifter piece engages correctly with the lifter arm during assembly. It may be necessary to pull the lifter arm forward to allow assembly to take place.**
4. Fit and tighten the bolts to **9 Nm**. Tighten the bolts in a diagonal sequence.
 5. Refit the coolant pipe, tightening its fixing to **9 Nm**.
 6. Refit the water pump as described on page 12.8.
 7. Refit the radiator as described on page 12.13.

Clutch

Removal

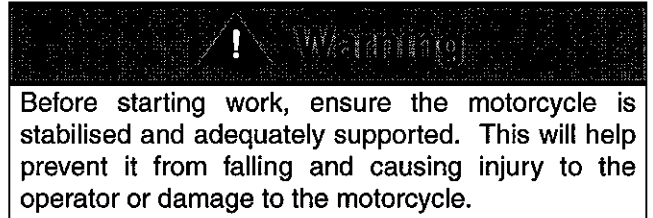

Before starting work, ensure the motorcycle is stabilised and adequately supported. This will help prevent it from falling and causing injury to the operator or damage to the motorcycle.

1. Remove the clutch cover as described on page 4.5.
2. Undo the bolts, withdraw the springs and remove the clutch pressure plate.

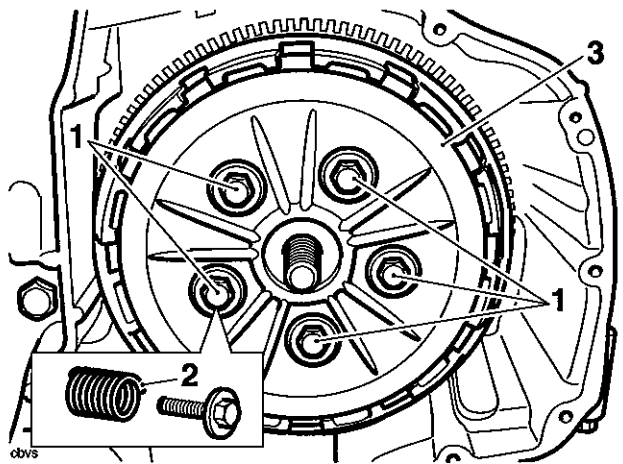

1. Pressure plate bolts
 2. Springs
 3. Pressure plate
3. Remove the lifter piece, needle bearing and thrust washer.

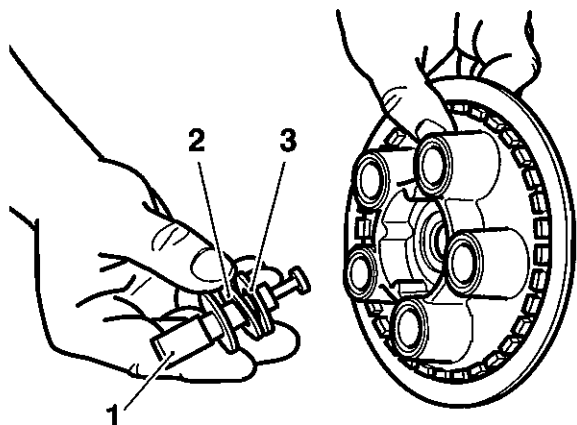

1. Lifter piece
2. Needle bearing
3. Thrust washer

Clutch

- Remove all the clutch friction plates and steel plates together with the anti-judder seat washer and spring. Note the orientation of all components as they are removed.



cbvu

- Friction Plates
- Steel Plate
- Anti-judder Seat Washer
- Anti-judder Spring

Note:

- The inner and outermost friction plates are different to the remainder and are also different to each other. They must not be fitted in any other positions.
 - Refer to the following page of this section for details of clutch friction plate inspection.
 - It is not normally necessary to disassemble the clutch further, but if the clutch inner and outer drums are to be removed, proceed as follows:
- Engage any gear and lock the inner and outer clutch drums together using service tool 3880025-T0301.

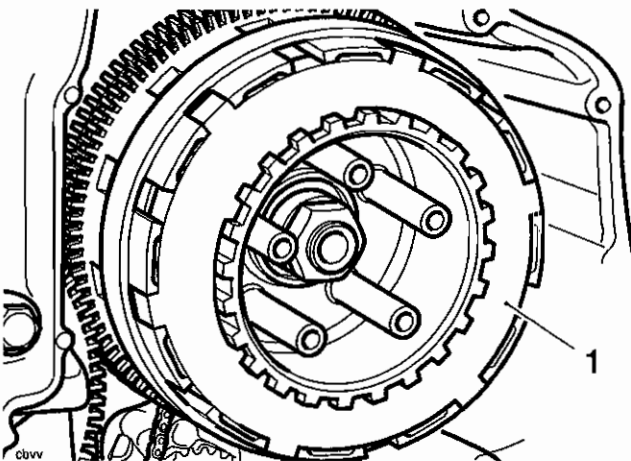

cbvv

- Service tool 3880025-T0301

- Depress the rear brake pedal to prevent the engine from turning, and then release the clutch centre nut.
- Remove the centre nut, Belleville washer, plain washer, clutch inner drum and thrust washer.

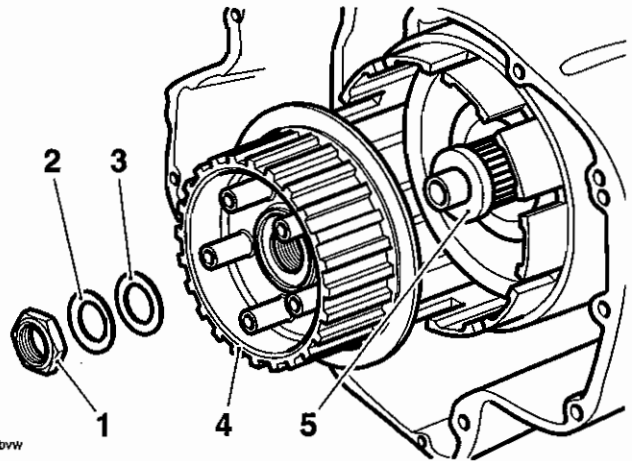

cbvw

- Centre Nut
- Belleville washer
- Plain washer
- Inner Drum
- Thrust Washer

- Slide the clutch outer drum outwards from the engine, collecting the bearing sleeve on removal of the drum.

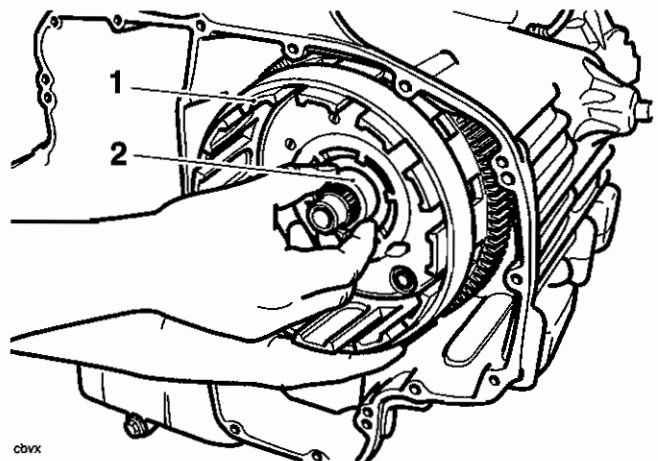

cbvx

- Outer drum
- Bearing sleeve

Friction Plate Inspection

Thickness

1. If any friction plate thickness is outside the service limit, replace the friction plates as a set.

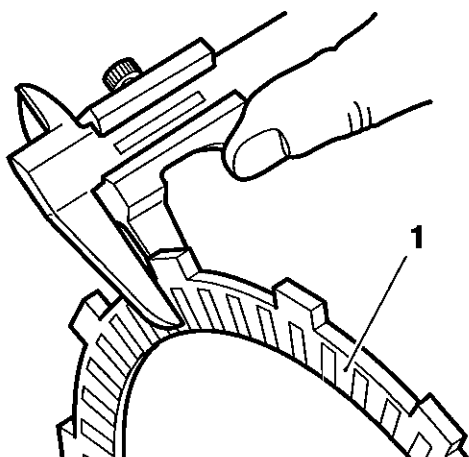

cbvy

1. Clutch friction Plate

| Friction plate thickness - all plates | |
|---------------------------------------|----------------|
| Standard | 3.72 – 3.88 mm |
| Service limit | 3.5 mm |

2. Check all plates for bend and warp as follows: Place the plate being checked on a clean surface plate and attempt to pass a feeler gauge of the maximum service limit thickness between the friction plate and surface plate. If the feeler gauge can be passed beneath the friction plate at any point, renew the plates as a set.

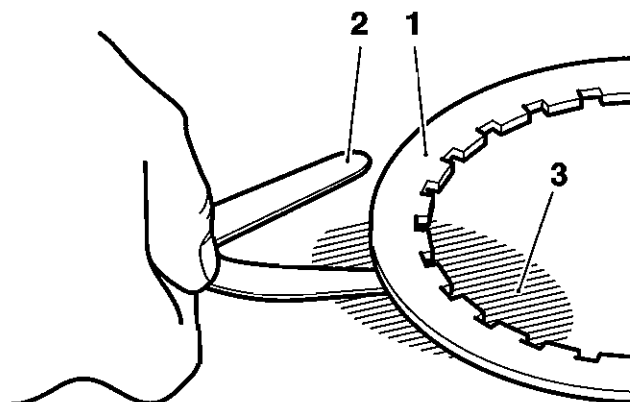

cbvz

1. Friction Plate
2. Feeler Gauge
3. Surface Plate

| Friction plate bend/warp | |
|--------------------------|---------|
| Service limit | 0.30 mm |

Assembly

1. Position the bearing sleeve then the clutch outer drum to the input shaft.
2. Align the oil pump drive pegs with the corresponding holes in the rear of the clutch outer drum.

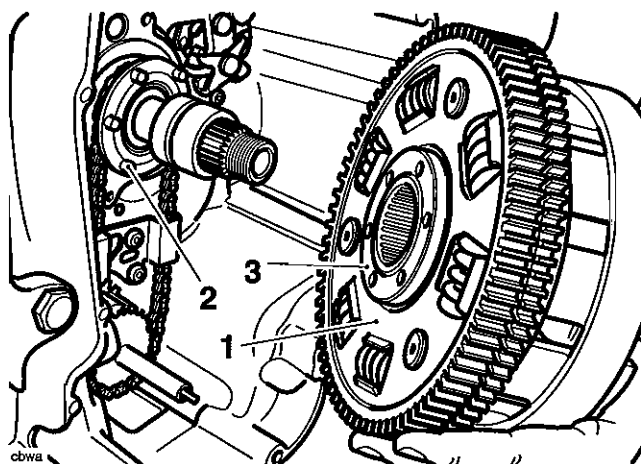

1. Clutch outer drum
2. Oil pump sprocket drive pegs
3. Oil pump drive holes

Clutch

3. Pre-load and align the primary gear and backlash eliminator with the crank gear. Align the gears through the hole arrowed below.

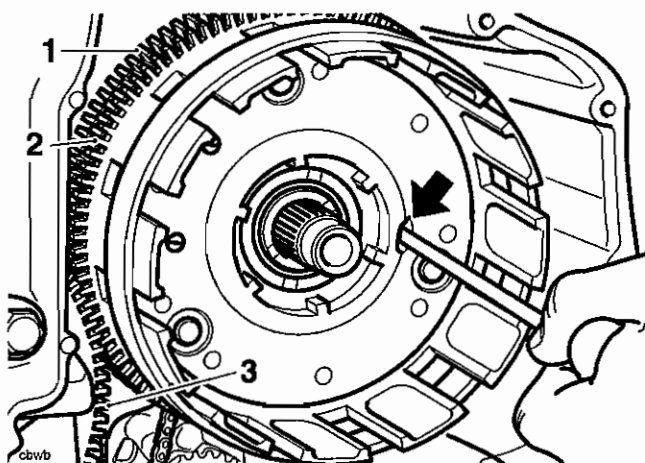

1. Primary gear
2. Backlash eliminator
3. Crank gear
4. Arrowed; alignment hole

Note:

- When the outer drum is correctly fitted and the gears are pre-loaded correctly, the bearing sleeve will be a flush fit with the clutch drum face. In addition, a groove around the input shaft will be visible.
4. Fit the thrust washer to the shaft.

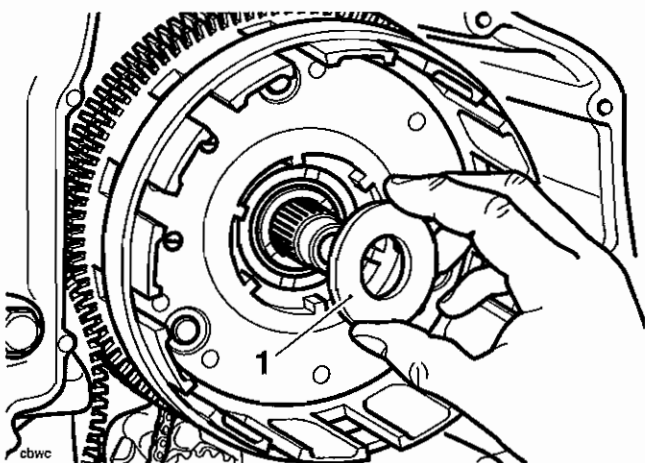

1. Thrust washer
5. Fit the clutch inner drum.
6. Refit the plain washer, fit a new Belleville washer ('out' mark facing outwards), and refit the centre nut.

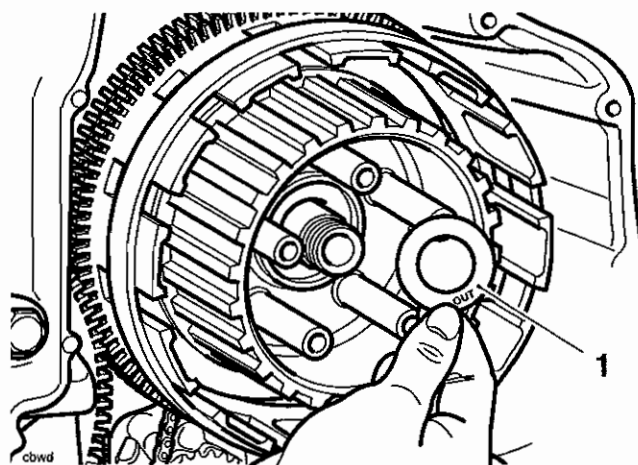

1. Belleville Washer 'Out' Mark

7. Lock the inner and outer drums together using service tool 3880025-T0301. Depress the rear brake pedal to prevent the engine from turning, and tighten the clutch centre nut to **105 Nm**. Remove the service tool,

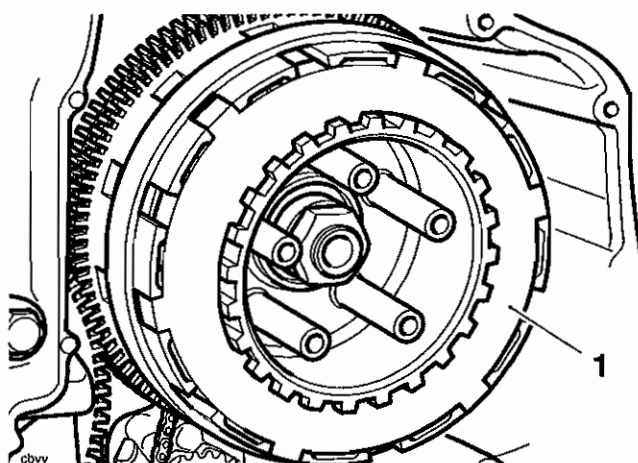

1. 3880025-T0301

8. Disengage second gear and check for free rotation of the clutch inner drum.
9. Coat all clutch friction plates in clean engine oil
10. Fit the friction plates, steel plates, anti-judder seat and spring to the clutch basket, in the same order as noted during removal.

Note:

- The inner and outermost friction plates are different to the remainder and are also different to each other. They must not be fitted in any other positions.

11. Refit the clutch pull rod.
12. Refit the clutch pressure plate together with the springs and bolts. Tighten the bolts to **10 Nm**.

Note:

- **The pull rod should be free to move in and out and also it should be free to turn.**
13. Fit the clutch cover as described on page 4.7.

This page intentionally left blank

5 Crankshaft

Table of Contents

| | |
|--|------|
| Exploded View - Crankshaft, Connecting Rod and Piston | 5-2 |
| Exploded View – Crankcase Fixings | 5-3 |
| Exploded View - Crankcase and Liners | 5-4 |
| Crankcases | 5-5 |
| Removal | 5-5 |
| Disassembly | 5-5 |
| Assembly | 5-7 |
| Crankshaft | 5-9 |
| Removal | 5-9 |
| Installation | 5-9 |
| Connecting Rods | 5-10 |
| Removal | 5-10 |
| Installation | 5-10 |
| Right hand (exhaust) side | 5-11 |
| Connecting Rod Big End Bearing Selection/Crankpin Wear Check | 5-12 |
| Connecting Rod Bearing Selection | 5-13 |
| Crankshaft Main Bearing/Journal Wear | 5-13 |
| Checking crankshaft clearance using Plastigage | 5-13 |
| Crankshaft End Float | 5-14 |
| Pistons | 5-15 |
| Disassembly | 5-15 |
| Piston Wear Check | 5-15 |
| Piston Rings/Ring Grooves | 5-16 |
| Piston Ring Gap | 5-16 |
| Piston Assembly | 5-16 |
| Cylinder Wear | 5-18 |
| Cylinder Liners | 5-18 |
| Removal | 5-18 |
| Installation | 5-19 |

Crankshaft

Exploded View - Crankshaft, Connecting Rod and Piston

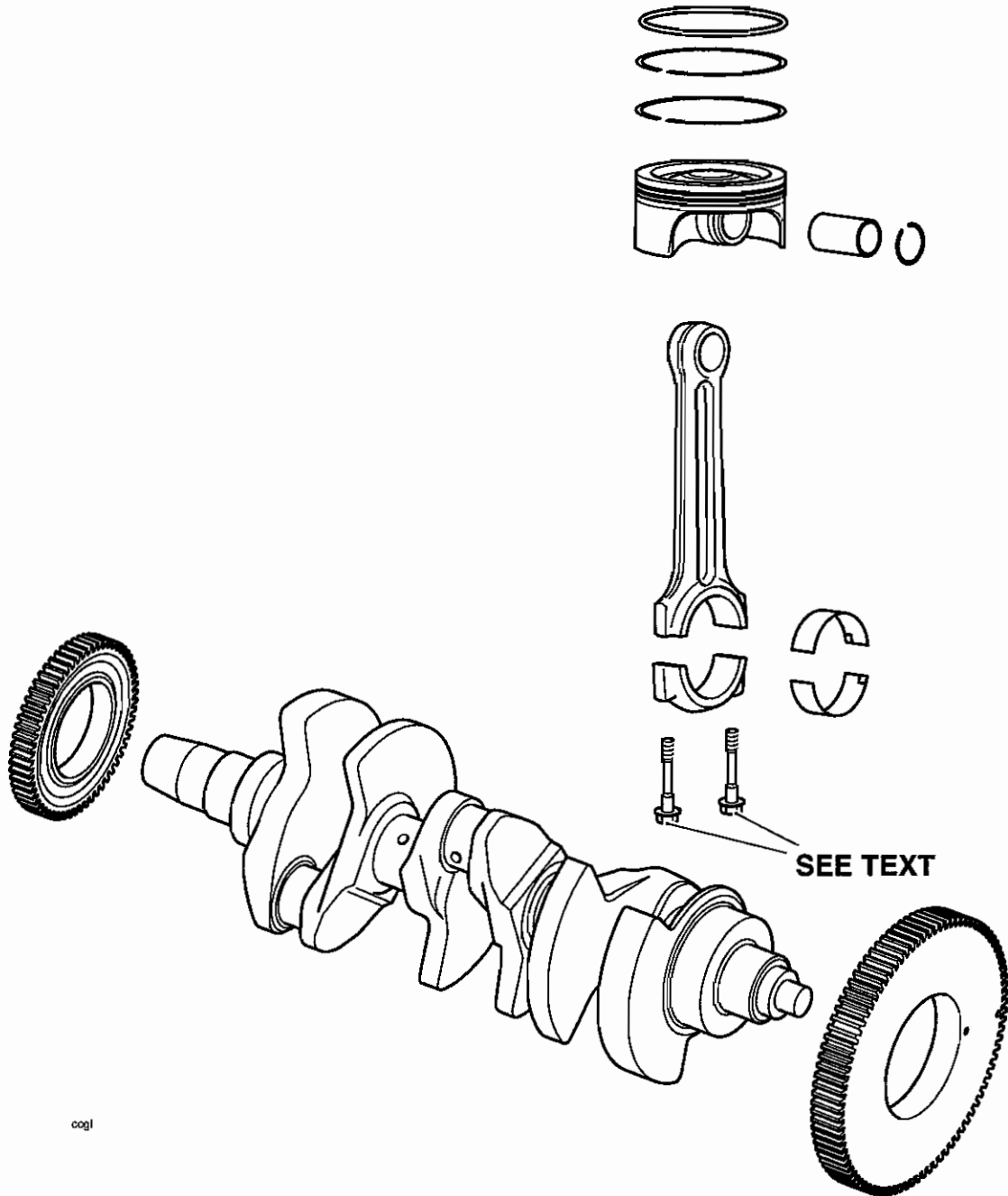

0091

Exploded View – Crankcase Fixings

ALL FIXINGS - SEE TEXT

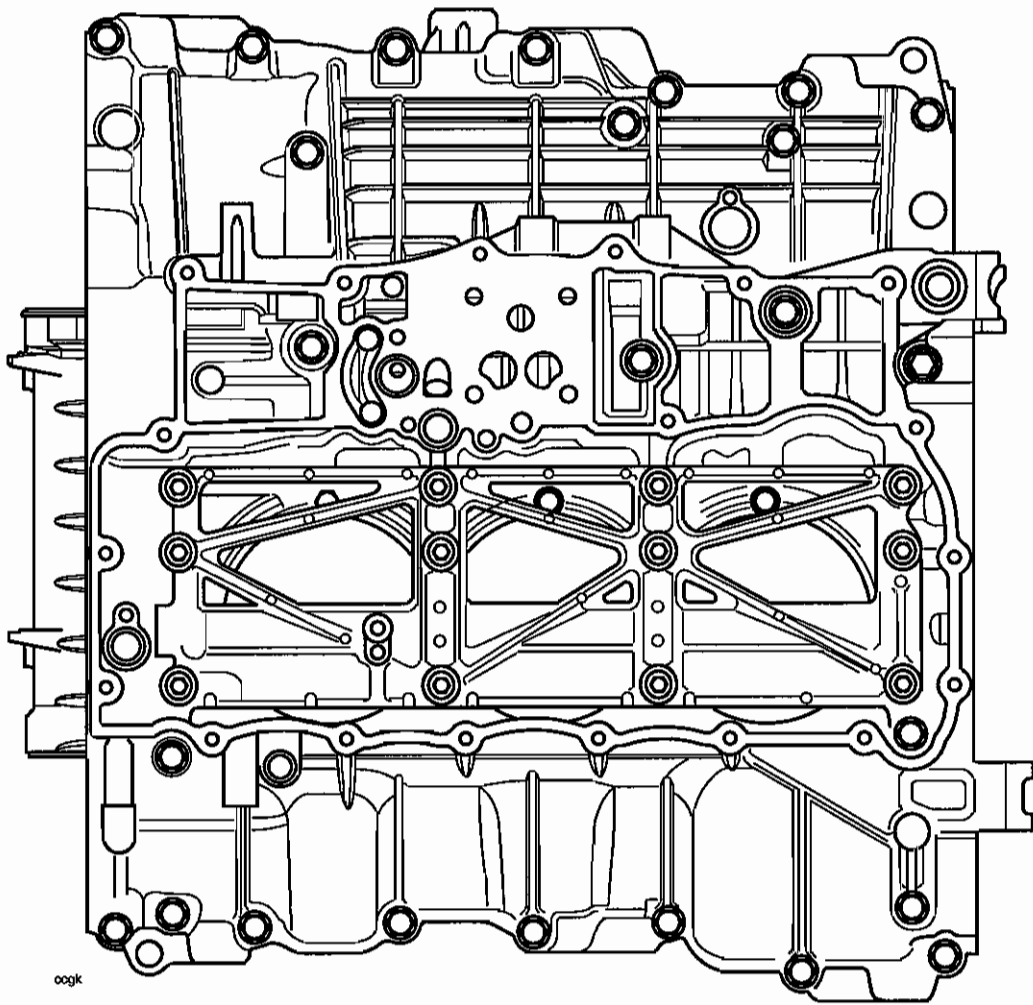

Crankshaft

Exploded View - Crankcase and Liners

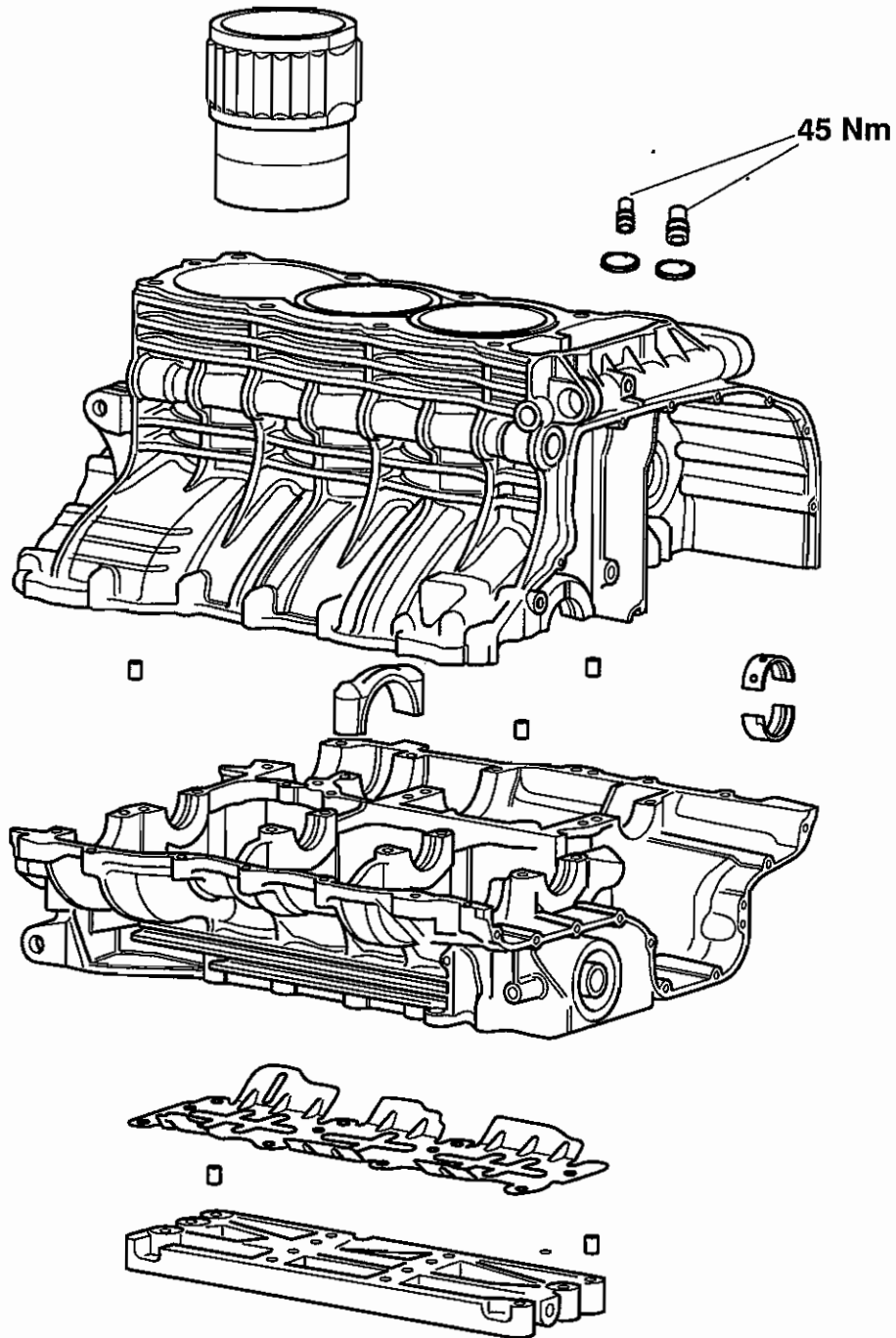

ccgj

Crankcases

Warning

The following procedures often require lifting of heavy components. To avoid injury, always lift heavy components with a hoist or block and tackle and never attempt to manually lift items that are too heavy. Injury may result from failure to use the correct lifting equipment.

Caution

The upper and lower crankcases are machined as a matched set and must never be assembled to non-matching halves. Doing so will cause seizure of the engine.

Note:

- The crankcase halves may be separated with the cylinder head fitted.

Removal

1. Remove the engine from the frame (see page 10.2).
2. Remove the clutch (see page 4.7).
3. Remove the starter motor (see page 18.18).
4. Remove the alternator (see page 18.15).
5. Remove the oil pump drive and pressure oil pump (see page 9.11).
6. Remove the torsional damper shaft (see page 8.11).
7. Remove the sump (see page 9.9).
8. Remove the cam chain (see page 3.6).

Disassembly

1. Remove the oil pipes from the lower crankcase.

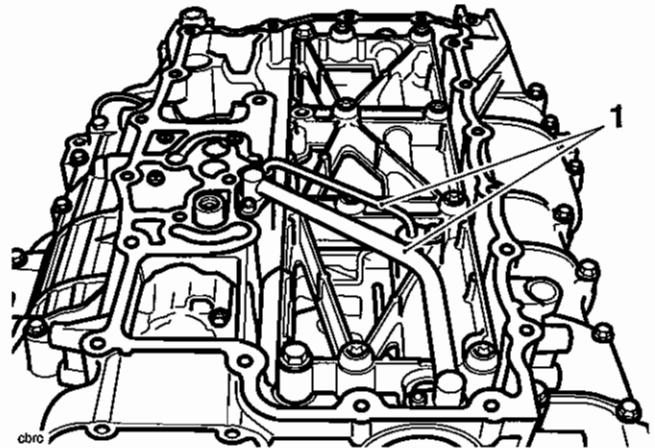

1. Oil pipes

2. Remove the non-return valve from the scavenge oil pump, by gently pulling it outwards from its location.

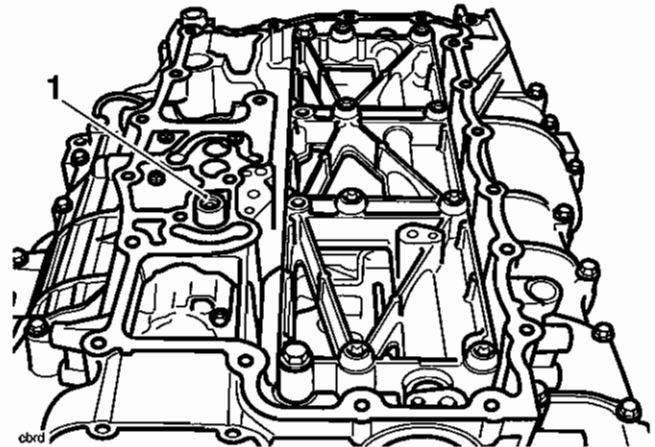

1. Non-return valve

3. In the sequence shown below, release the bolts securing the main bearing ladder to the crankcases.

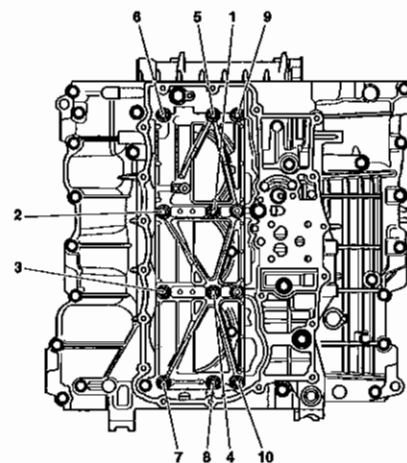

Main bearing ladder bolt release sequence

Crankshaft

4. Collect the bolts, then detach the ladder and baffle plate from the crankcase noting the position of both location dowels, which should be removed for safe-keeping.

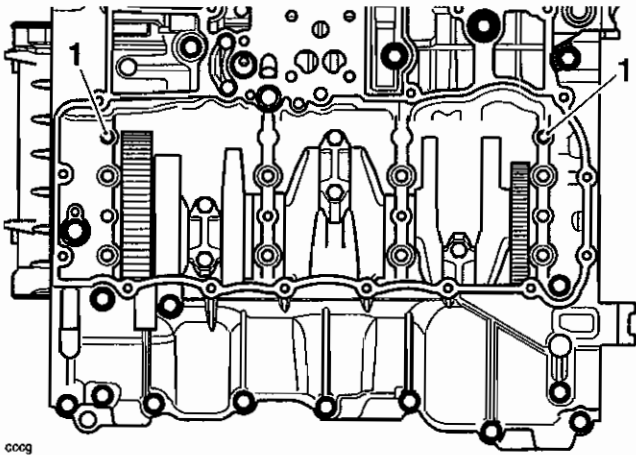

1. Dowels

5. Starting from bolt 11, release the lower crankcase bolts in the sequence shown in the diagram below. Remove and discard the bolts.

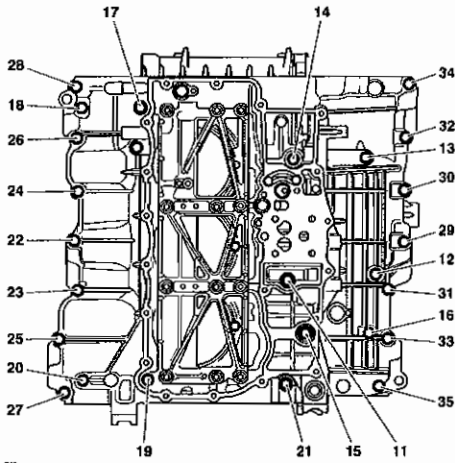

Lower Crankcase Bolt Release Sequence

6. From inside the rear of the crankcases, collect the bearing cap securing the output shaft to the lower crankcase.

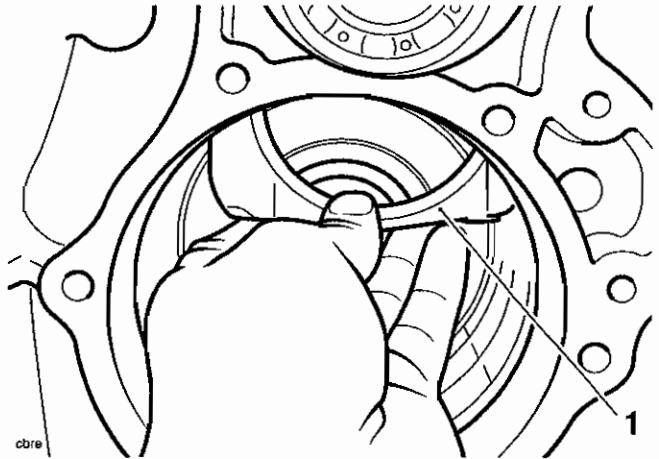

1. Output shaft bearing cap

Note:

- Always check that all bolts have been released before attempting to separate the cases. Bolts are fitted in discreet locations such as under the pressure oil pump and inside hollow bosses.
7. Separate the lower and upper crankcases noting the position of the three location dowels, which should be removed for safe-keeping.

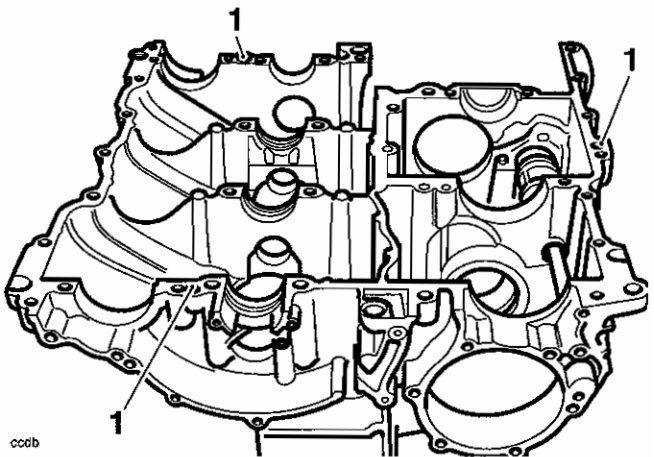

1. Dowel locations

8. At this point, the balancer shaft may be removed. To detach the crankshaft, the big end caps must also be removed (see page 5.10).

Caution

Do not use levers to separate the upper and lower sections of the crankcase as damage to the crankcases could result.

Assembly

1. Use high flash-point solvent to clean the crankcase mating faces. Wipe the surfaces clean with a lint-free cloth.
2. Ensure that the three locating dowels are in position in the upper crankcase.

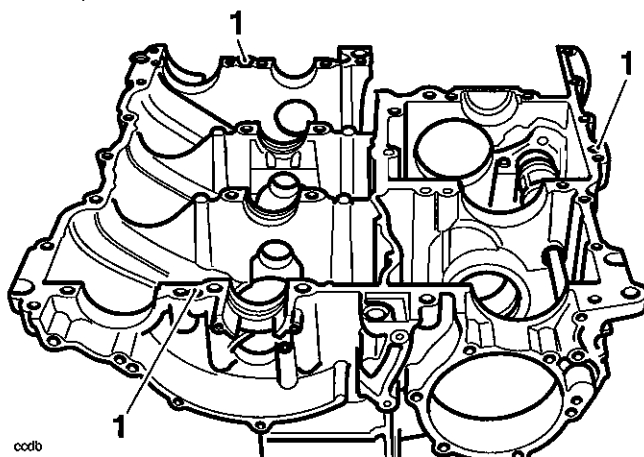

1. Dowels

3. Apply a thin bead of silicone sealant to the lower crankcase mating faces (at the factory, Three Bond 1207B is used).

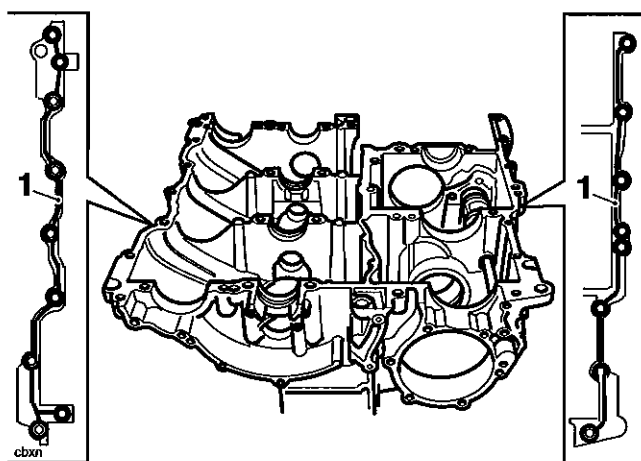

Sealer areas

⚠ Caution

Do not use excessive amounts of sealer. The extra sealer may become dislodged and could block the oil passages in the crankcases, causing severe engine damage.

4. Install and lubricate the crankshaft main bearing shells with clean engine oil (see bearing selection on page 5.13 before proceeding).
5. Install the crankshaft to the upper crankcase.

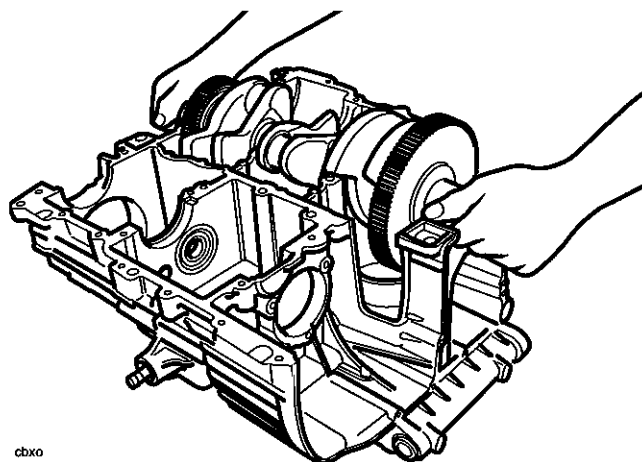

cbxo

Installing the crankshaft

6. Install and lubricate the balancer ensuring it is 'timed' to the crankshaft correctly (see page 7.4).
7. Lubricate the crankshaft journals with clean engine oil.
8. Position the lower crankcase to the upper. An assistant may be required to support the crankcase during alignment.
9. Fit the screws into the lower crankcase and hand tighten them.
10. Position the main bearing ladder and baffle to the crankcase (baffle lugs facing into the engine).

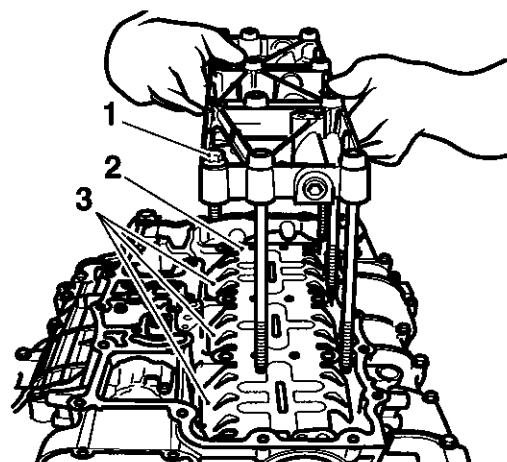

cbxp

1. Main bearing ladder
2. Baffle
3. Baffle lugs

11. Tighten the crankcase screws as follows:

Note:

- The crankcase screws are tightened in stages.

Crankshaft



Caution

Failure to follow the correct screw tightening sequence may result in permanent crankcase damage.

Stage 1 - all screws

In the correct sequence, tighten all crankcase fixings to 10 Nm.

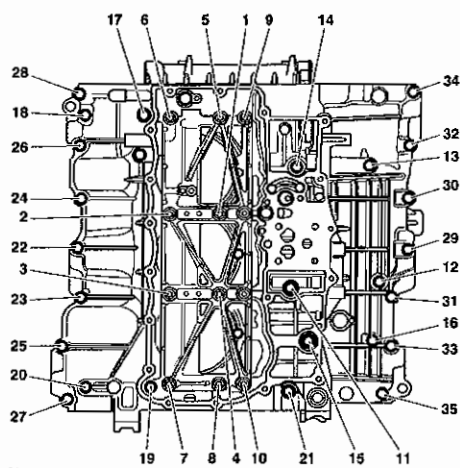

Crankcase fixing tightening sequence, all fixings

Stage 2

In the correct sequence, tighten fixings 1 through 8 to 40 Nm.

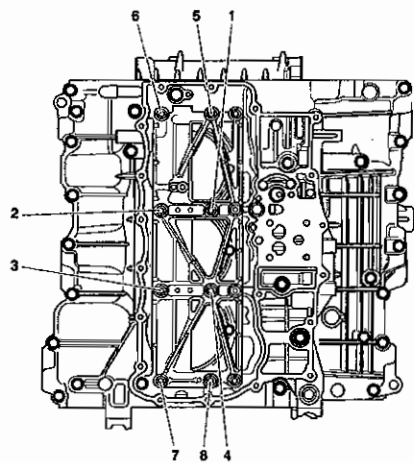

Crankcase bolt tightening sequence, fixings 1-8

Stage 3

In the correct sequence, tighten fixings 9 through 35 to 28 Nm.

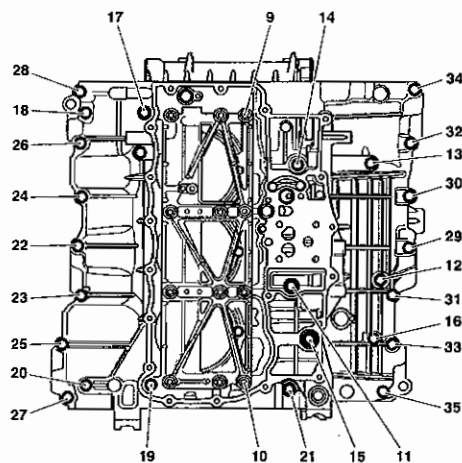

Crankcase fixing tightening sequence, fixings 9-35

Crankshaft

Removal

1. Remove the engine from the frame (see page 10.2).
2. Separate the lower and upper crankcases (see page 5.5).
3. Lift the balancer out of the upper crankcase.

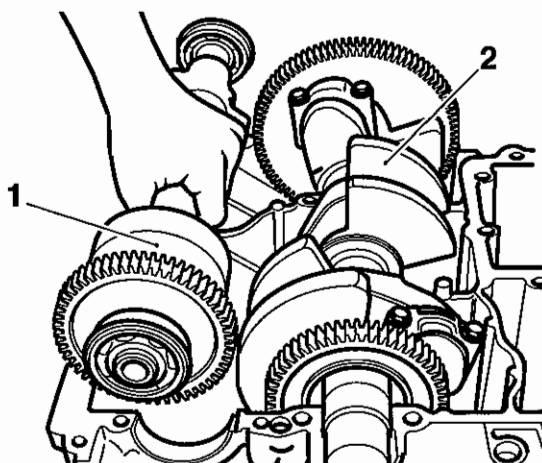

cbri

Removing the balancer

4. Remove the connecting rod big end caps (see page 5.10). Discard the bolts after removal.
5. Lift the crankshaft from the upper crankcase. Support the connecting rods during crankshaft removal to prevent damage to the rods, liners and upper crankcase.

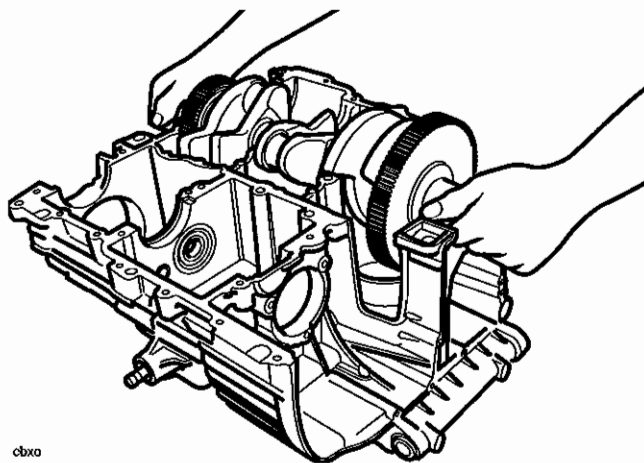

cbxo

Removing the crankshaft

Installation

! Caution

Always check the main bearing journal clearance (see page 5.13), before final assembly of the crankshaft. Failure to correctly select crankshaft bearings will result in severe engine damage.

1. Select and fit new main and big end bearing shells using the selection processes detailed on pages 5.12 and 5.13.
2. Lubricate all bearings with engine oil.
3. Ensure that the crankshaft is clean, and that the oil ways within the crankshaft are clean and free from blockages and debris.
4. Install the crankshaft ensuring that the crankpins align with the corresponding big ends.

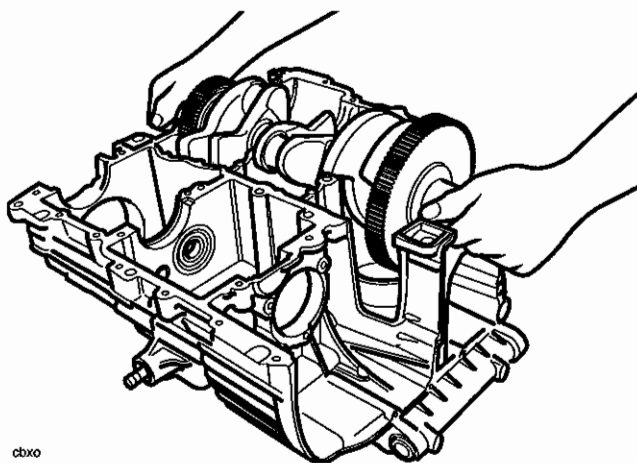

cbxo

Installing the crankshaft

5. Align the connecting rod big ends to the crankpins.
6. Fit the big end caps and tighten them (see page 5.10 for the tightening sequence and torque).
7. Install the balancer (see page 7.4).
8. Assemble the crankcases (see page 5.7).

Crankshaft

Connecting Rods

Removal

Note:

- The connecting rods and cap are etch-marked on one side to identify their correct orientation. However, the cylinder from which they are individually removed should also be identified, using a laundry marker or similar.

1. Remove the engine from the frame (see section 10.2).
2. Separate the lower and upper crankcases (see page 5.5).
3. Remove the cylinder head (see page 3.5).
4. Remove the connecting rod bolts. Discard the bolts.

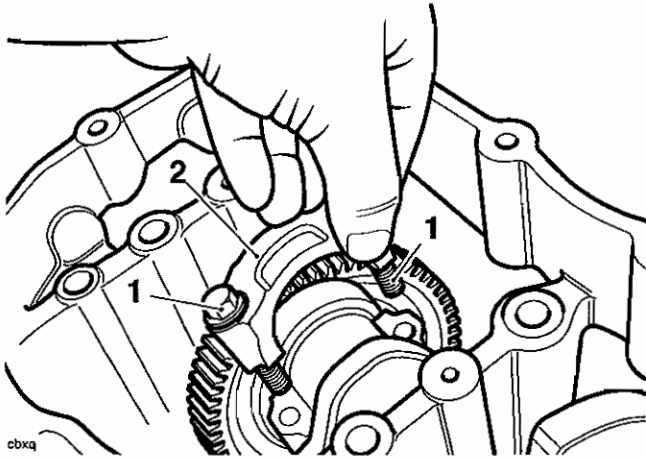

1. Connecting rod bolts

2. Connecting rod cap

5. Collect the big end caps.
6. Push the connecting rod up through the liner and collect the piston and connecting rod from the liner top.
7. Label the assembly to identify the cylinder from which it was removed.
8. Mark the position of each liner in the crankcase to ensure it is reassembled in its original position.
9. Remove the cylinder liners using tool T3880061, (see page 5.18).

Installation

Note:

- Connecting rod bolts and nuts are treated with an anti-rust solution, which must not be removed.

1. Clean the connecting rod with high flash-point solvent.
2. Select new big end bearings (see page 5.12).
3. Fit the selected big end shells to the connecting rods and big end caps.
4. Fit the piston and connecting rod assemblies into the liners as described on page 5.17.
5. Thoroughly clean the liner removing all traces of old silicone sealer.
6. Remove all traces of sealer from the crankcase bores.
7. Apply a thin bead of silicone sealer to the liner to crankcase mating face.

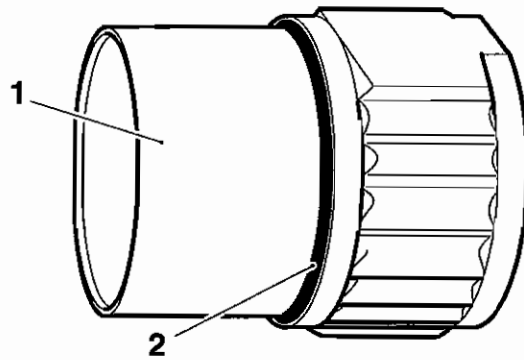

cbxc

1. Liner

2. Sealer Area

8. Fit the liner into the crankcase ensuring that the arrow on the piston faces to the right hand side of the engine/bike (the same side as the exhaust headers).

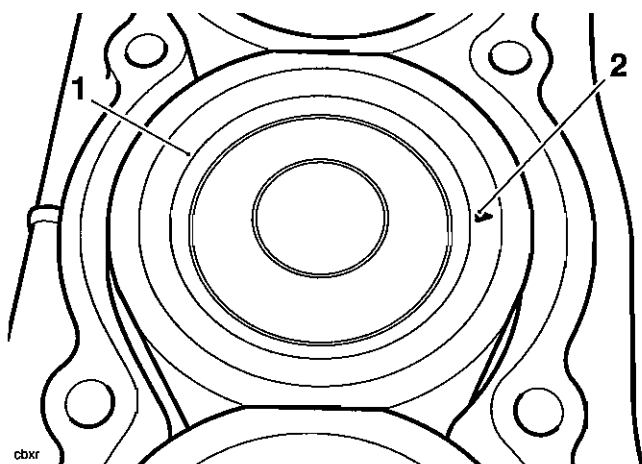

1. Piston
2. Arrow

Right hand (exhaust) side

Note:

- Ensure that the piston/liner/connecting rod assemblies align correctly with the crankpins during assembly into the crankcase.

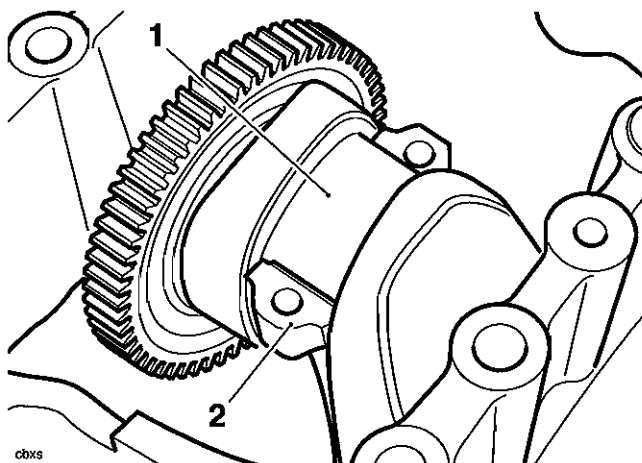

1. Crankpin
2. Big End

9. Align the connecting rod to the crankshaft and fit the big end cap. Tighten the **NEW** cap bolts as follows:

Warning

The torque characteristics of the connecting rod bolts are sensitive to the rate at which they are tightened. If all the torque is applied in one action, the bolts will be stretched beyond their yield point. This may cause bolt breakage resulting in engine damage, loss of motorcycle control and an accident.

Lubricate the under-head and thread areas of the bolts with undiluted molybdenum disulphide grease. Tighten the bolts, in two stages as follows:-

- Tighten to **14 Nm**.
- Tighten through 120° of bolt rotation as measured using the Triumph torque turn gauge 3880105-T0301.

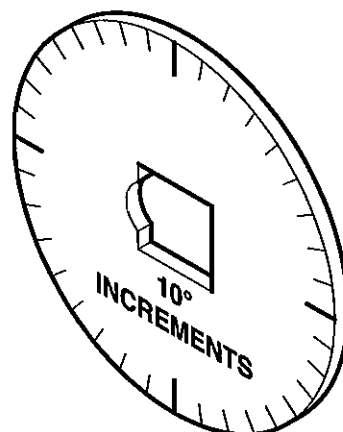

Service Tool 3880105-T0301

Warning

Always renew the big end bolts. The bolts are torqued near to their yield point when first installed and are severely weakened if reused. Re-using the original bolts may cause bolt breakage resulting in engine damage, loss of motorcycle control and an accident.

Crankshaft

Connecting Rod Big End Bearing Selection/Crankpin Wear Check

1. Measure the bearing and crankpin clearance as follows.

Note:

- The crankpin clearances are measured using 'Plastigage' (Triumph part number 3880150-T0301). Do not turn the connecting rod and crankshaft during the clearance measurement as this will damage the 'Plastigage'.
2. Remove the big end cap from the journal to be checked.
 3. Wipe the exposed areas of the crankpin, and the bearing face inside the cap.
 4. Apply a thin smear of grease to the journal and a small quantity of silicone release agent to the bearing.
 5. Trim a length of the Plastigage to fit across the journal. Fit the strip to the journal using the grease to hold the Plastigage in place.
 6. Lubricate the threads of the bolt and under-head area with undiluted molybdenum disulphide grease. Refit the bearing and cap and tighten the big end bolts as described earlier.
 7. Release the bolts and remove the cap being measured. Using the gauge provided with the Plastigage kit, measure the width of the compressed Plastigage.

Note:

- If the measured clearance exceeds the service limit, measure the crankpin diameter.

| Crankpin diameter | |
|-------------------|--------------------|
| Standard | 40.946 – 40.960 mm |
| Service limit | 40.922 mm |

Note:

- If any crankpin has worn beyond the service limit, the crankshaft must be replaced. Due to the advanced techniques used during manufacture, the crankshaft cannot be reground and oversize bearings are not available.

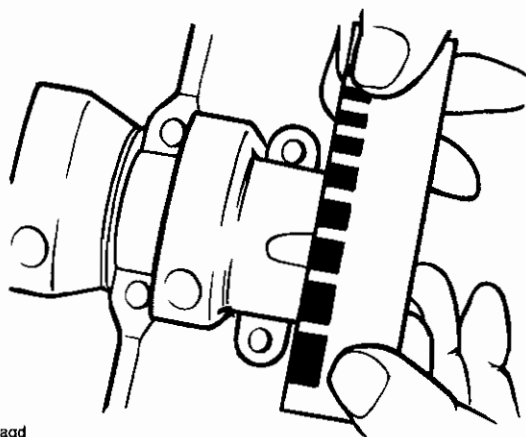

Checking the Measured Clearance

| Con rod big end bearing/crankpin clearance | |
|--|------------------|
| Standard | 0.065 - 0.035 mm |
| Service Limit | 0.100 mm |

Connecting Rod Bearing Selection

Note:

- **Optimum running clearance is achieved by using selective big end bearings. For further information on bearing part number to colour cross-references, refer to the parts information system.**

Select the correct big end bearing shell as follows:

1. Measure each crankpin diameter.
2. Select the correct bearings by matching the information found with the chart below.

Big end bearing selection chart

| Shell Colour | White | Red |
|-------------------|---------------------|---------------------|
| Crankpin diameter | 40.960 to 40.954 | 40.953 to 40.946 |

For instance:

Crankpin diameter 40.958
 Required Bearing White

Note:

- **Repeat the measurements for all connecting rods and their respective crankpins. It is normal for the bearings selected to differ from one connecting rod to another.**

 **Warning**

Always confirm, using the Plastigage method, that the running clearance is correct before final assembly. Severe engine damage could result from incorrect clearance, resulting in loss of motorcycle control and an accident.

Crankshaft Main Bearing/Journal Wear

Using selective bearings compensates for minor differences in crankshaft main bearing journal and crankcase dimensions. For further information on bearing part number to colour cross-references, refer to the parts information system.

1. Measure the bearing to crankshaft main journal clearance using Plastigage (Triumph part number 3880150-T0301). Use the same method as described in connecting rod clearance measurement.

Checking crankshaft clearance using Plastigage

| Crankshaft main bearing/journal clearance | |
|---|------------------|
| Standard | 0.018 – 0.041 mm |
| Service limit | 0.100 mm |

2. If the clearance exceeds the service limit, measure the diameter of the crankshaft main bearing journal.

| Crankshaft main bearing journal diameter | |
|--|--------------------|
| Standard | 43.092 – 43.108 mm |
| Service limit | 43.068 mm |

Note:

- **If any journal has worn beyond the service limit, the crankshaft must be replaced. Due to the techniques used during manufacture, the crankshaft cannot be reground and oversize bearings are not available.**

Select bearings as follows:

1. Measure and record the diameter of each crankshaft main bearing journal.
2. Measure and record each main bearing bore diameter in the crankcase (bearings removed but all crankcase bolts fully torqued (see page 5.8).

Note:

- **The original crankcase bolts may be reused for bearing selection. Do not use new bolts as they may only be used once, even if the single use is related to bearing selection.**

Crankshaft

Compare the data found with the chart above to select bearings individually by journal.

| Shell Colour | White | Red | Red | Blue | Blue | Green |
|-----------------------------|------------------|------------------|------------------|------------------|------------------|------------------|
| Crankcase bore diameter | 46.105 to 46.097 | 46.105 to 46.097 | 46.114 to 46.106 | 46.114 to 46.106 | 46.123 to 46.115 | 46.123 to 46.115 |
| Crankshaft journal diameter | 43.108 to 43.100 | 43.099 to 43.092 | 43.108 to 43.100 | 43.099 to 43.092 | 43.108 to 43.100 | 43.099 to 43.092 |

For example:

Crankcase Bore 46.099 mm

Crankshaft Journal diameter 43.095 mm

Bearing Required BLUE

Note:

- It is normal for the bearings selected to differ from one journal to another.

It is also normal for there to be two options of bearing shell colour. In such cases, pick the shell size that gives the greater running clearance.

Crankshaft End Float

| Crankshaft end float | |
|----------------------|----------------|
| Standard | 0.05 – 0.20 mm |
| Service limit | 0.40 mm |

Note:

- Crankshaft end float is controlled by the tolerances in crankshaft and crankcase machining. Thrust washers are not used. If crankshaft end float is outside the specified limit, the crankshaft and/or the crankcases must be replaced.



Warning

Always confirm, using the Plastigage method, that the running clearance is correct before final assembly. Severe engine damage could result from incorrect clearance resulting in loss of motorcycle control and an accident.

Pistons

Disassembly

1. Remove the cylinder head and liners (see page 3.5).

Caution

The cylinder liners and pistons are made of aluminium alloy and can therefore be easily damaged. Handle the cylinder liner and piston with care, ensuring the internal bore of the liner and the piston skirt are not scratched.

Note:

- It is not necessary to remove the connecting rods from the crankshaft, but the piston should be at the top of its stroke.
2. Remove the gudgeon pin circlip from one side of the piston.

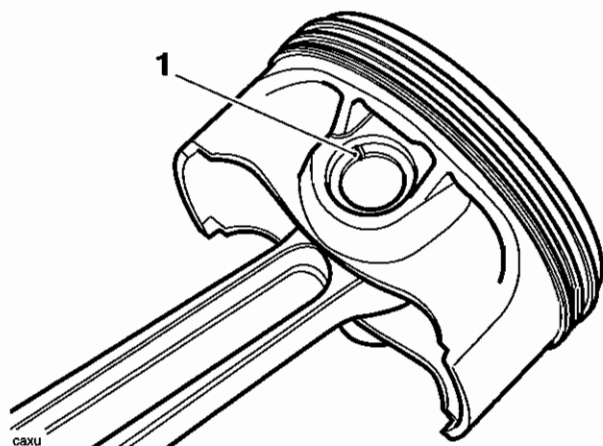

1. Gudgeon pin circlip

3. Remove the gudgeon pin by pushing the pin through the piston and rod toward the side from which the circlip was removed.

Note:

- If the gudgeon pin is found to be tight in the piston, check the piston for a witness mark caused by the circlip. Carefully remove the mark to allow the pin to be removed.
4. With the gudgeon pin removed, the piston can be detached from the con-rod.
 5. Remove the piston rings.

Note:

- The rings may be removed using a proprietary piston ring expander tool or, if a tool is not available, carefully spread the ring opening using thumb pressure then push up on the opposite side of the ring to remove it from the piston.

Piston Wear Check

1. Measure the piston outside diameter, 10 mm up from the bottom of the piston and at 90° to the direction of the gudgeon pin.

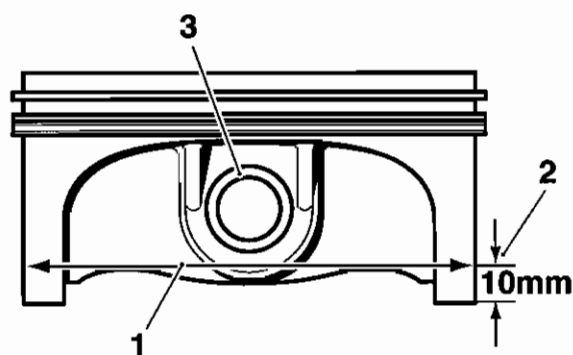

cbxv

1. Piston outside diameter
2. Measurement point (10 mm Up The Piston Skirt)
3. Gudgeon pin

| Piston outside diameter at 90° to Gudgeon Pin | |
|---|----------------------|
| All cylinders | 101.561 – 101.577 mm |
| Service limit | 101.511 mm |

Replace the piston if the measured diameter falls outside the specified limit.

Crankshaft

Piston Rings/Ring Grooves

1. Check the pistons for uneven groove wear by visually inspecting the ring grooves.
2. Clean the piston ring grooves.
3. Fit the piston rings to the pistons. Check, using feeler gauges, for the correct clearance between the ring grooves and the rings. Replace the piston and rings if outside the specified limit.

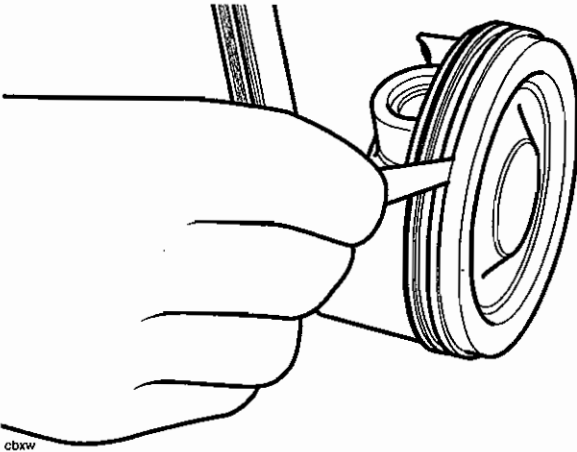

Checking piston ring to groove clearances

| Piston ring/Groove Clearance | |
|------------------------------|----------------|
| Top - standard | 0.02 – 0.06 mm |
| Top - service limit | 0.16 mm |
| Second - standard | 0.02 – 0.06 mm |
| Second - service limit | 0.16 mm |

Piston Ring Gap

Note:

- **Before final assembly the piston ring gap, when fitted in the liner, must first be checked.**

1. Place the piston ring inside the liner.
2. Push the ring into the top of the cylinder, using the piston to hold the ring square with the inside of the bore. Continue to push the ring into the bore until the third groove of the piston is level with the top of the liner around its full circumference.

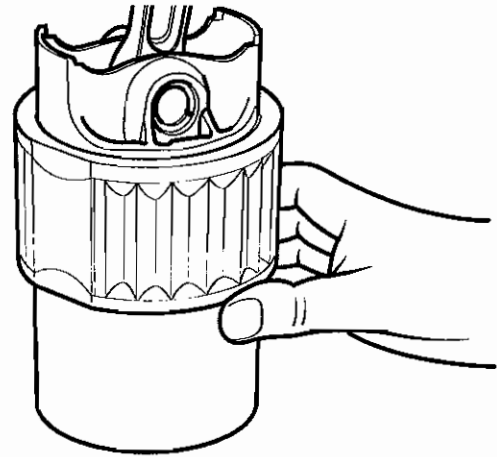

cbxx

Aligning piston rings using the piston

3. Remove the piston and measure the gap between the ends of the piston ring using feeler gauges.

| Piston Ring End Gap Tolerances | |
|--------------------------------|----------------|
| Top - standard | 0.20 – 0.35 mm |
| Top – service limit | 0.55 mm |
| Second - standard | 0.30 – 0.50 mm |
| Second - service limit | 0.675 mm |
| Oil control - standard | 0.20 – 0.70 mm |
| Oil control – service limit | 0.875 mm |

4. If the ring gap is found to be too small, the ring end must be carefully filed until the correct gap is achieved. If the gap is too large, replace the rings with a new set. If the gap remains too large with new rings fitted, both the piston and liner must be replaced.

Piston Assembly

1. Clean the piston ring grooves and fit the piston rings to the piston.

Note:

- **The top ring upper surface is marked 'N' and can be identified by a chamfer on the inside edge.**

The second ring upper surface is marked '2N' but is plain on the inside edge and has a bronze appearance.

All oil control rings can be fitted with either face upward.

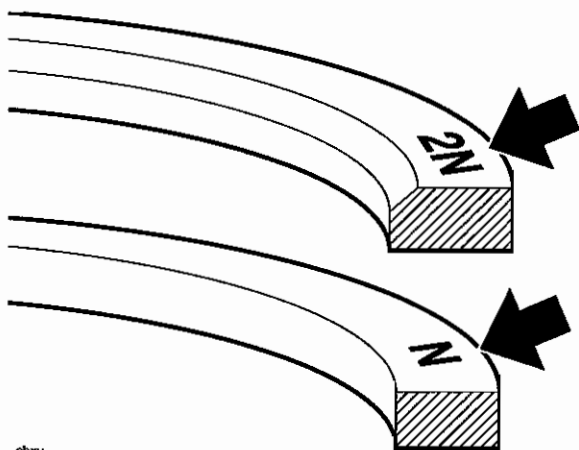

cbxy

Piston ring identification marks

2. Install a new circlip to one side of the piston.
3. Locate the piston to the connecting rod ensuring that the piston direction arrow points to the right hand (exhaust) side of the engine.

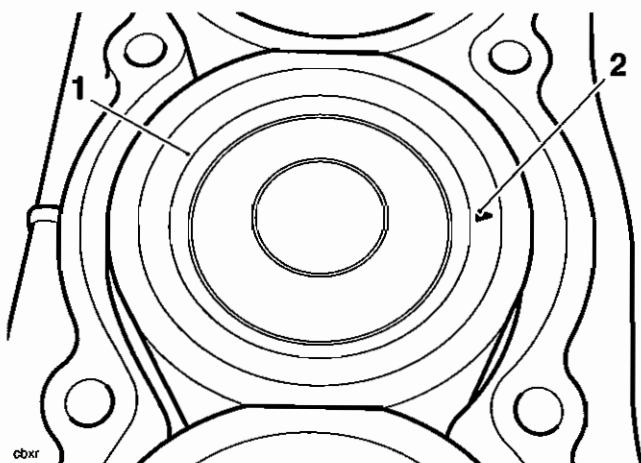

cbxr

1. Piston
2. Direction arrow

4. Align the small end in the connecting rod with the gudgeon pin hole in the piston.
5. Lubricate the piston, small end and gudgeon pin with clean engine oil and fit the gudgeon pin from the opposite side to the installed circlip.
6. Fit a new circlip to the remaining location in the piston then check that both are correctly installed. Rectify if necessary.

Warning

Re-using the original circlips may cause gudgeon pin detachment resulting in engine seizure, loss of motorcycle control and an accident.

7. The piston ring gaps must be arranged as shown in the diagram below.

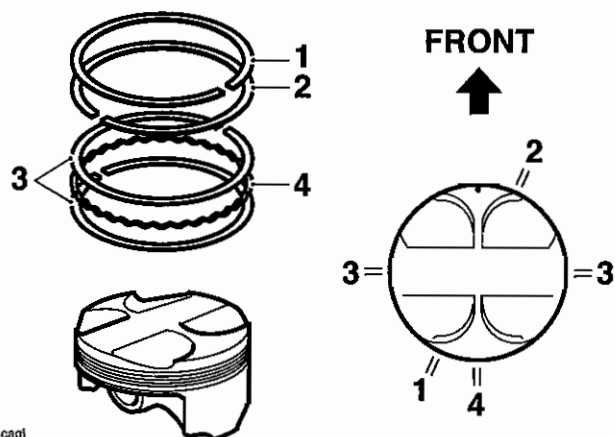

caqj

1. Top Ring
2. Second Ring
3. Steel Oil Control Rings
8. Oil Control Ring Expander

Note:

- The top ring gap should be positioned in the 7 o'clock position, the second ring gap in the 1 o'clock position and the steel oil control ring gaps in the 9 & 3 o'clock positions (one in each position).
9. Fit the piston into the bottom of the liner using a gentle rocking motion to engage the rings in the bore.

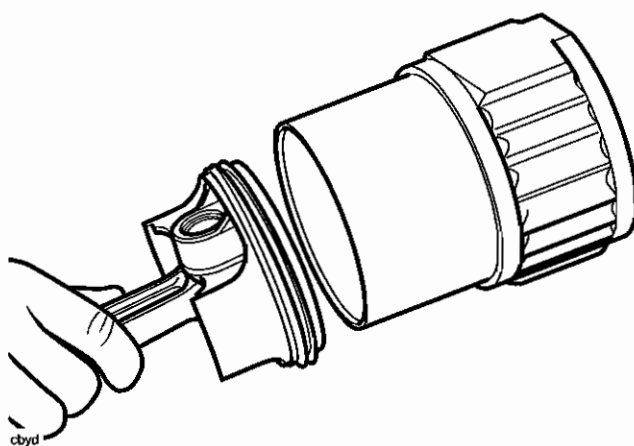

cbzd

Fitting a piston into a liner

Crankshaft

Cylinder Wear

1. Measure the internal diameter of each cylinder liner using an internal micrometer or Mercer gauge. Always check in two places, at 90° to each other, as well as at three heights in the liner.

| Cylinder liner internal diameter | |
|----------------------------------|--------------------|
| Standard | 101.591 – 1.609 mm |
| Service limit | 101.659 mm |

Check the diameter at points 1, 2 and 3.

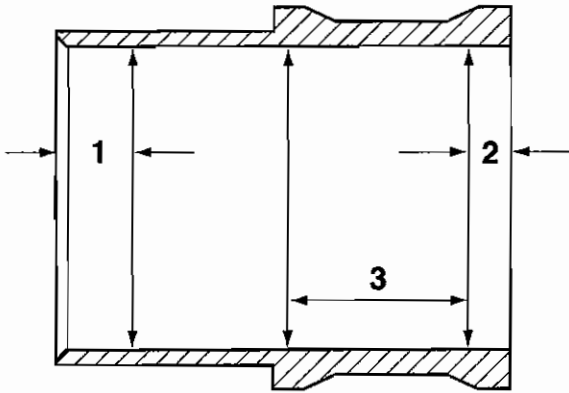

Checking Positions For Bore Wear Check (bore shown in section)

2. If any reading is outside the specified limits, replace the liner and piston as an assembly.

Cylinder Liners

Removal

1. Mark each liner to identify correct orientation and the cylinder number from which it has been removed.
2. Turn the crankshaft until the piston in the liner to be removed is at the bottom of its stroke.
3. Check that the locking nut on tool T3880061 is loose, then fully unscrew the extraction nut.

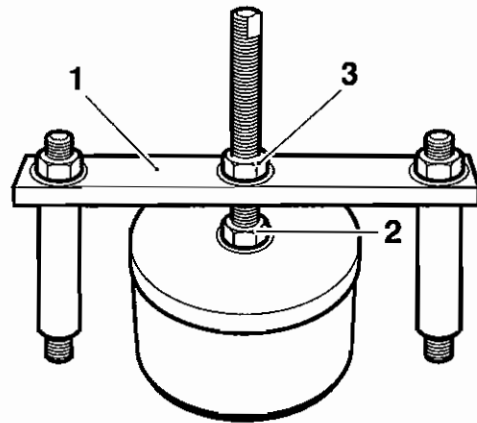

1. Tool T3880061
2. Locking nut
3. Extraction nut



Caution

The cylinder liners and pistons are made of aluminium alloy and can therefore be easily damaged. Handle the cylinder liner and piston with care, ensuring the internal bore of the liner and the piston skirt are not scratched.

- Carefully fit the rubber section of the tool fully into the cylinder liner, positioning studs supplied with the tool diagonally across a pair of head bolt-holes.

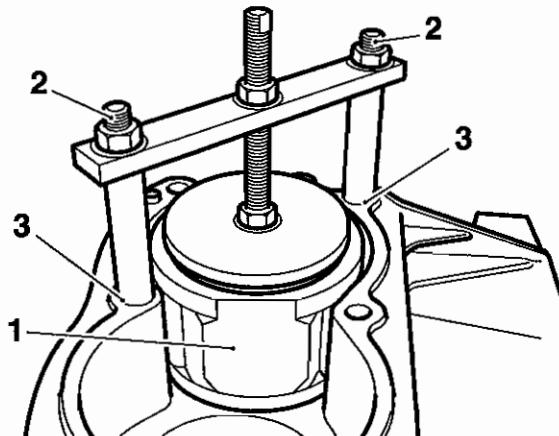

cbya

- Cylinder liner
- Studs
- Head-bolt holes

- Fully engage the bolt threads in the head bolt holes. It is not necessary to fully tighten the bolts.
- Turn the locking nut clockwise until the rubber sleeve on the tool tightly grips the bore of the liner.
- Turn the extraction nut clockwise sufficient to raise the liner and break the seal between the liner and crankcase.

Note:

- It is not necessary (or possible) to fully extract the liner using this tool. Once the seal is broken, the tool must be removed and the liner extracted by hand.
- Turn the locking nut anticlockwise to release the liner.
 - Once the seal on the liner is released, remove the tool and manually remove the liner.

Installation

- Thoroughly clean the liner removing all traces of old silicone sealer.
- Remove all traces of sealer from the crankcase bores.
- Apply a thin bead of silicone sealer to the liner to crankcase mating face.

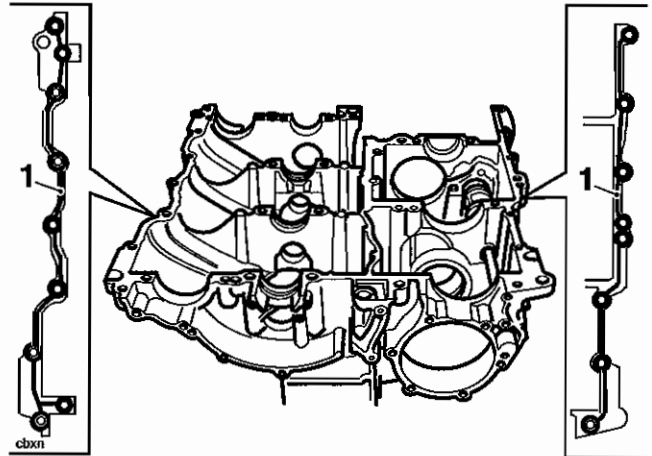

- Liner
- Sealer Area

- Apply a thin bead of silicone sealer to the liner to crankcase mating face.

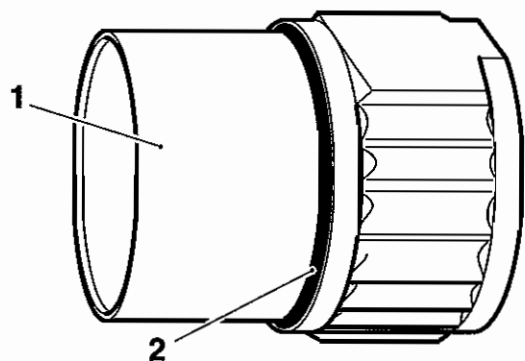

cbyc

- Liner
- Sealer area

Crankshaft

- Carefully fit each liner over the piston using a gentle rocking motion to allow compression of the piston rings.

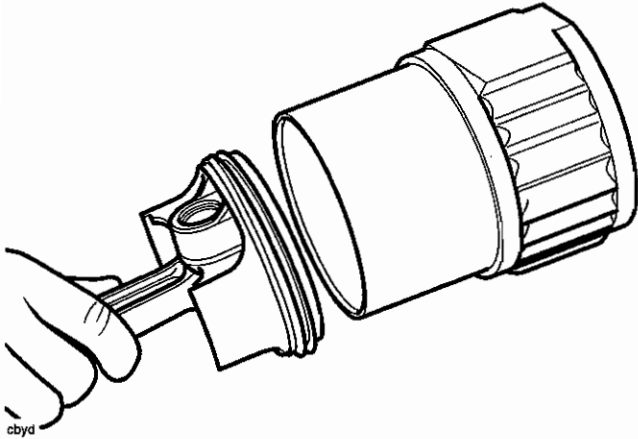

Fitting a piston into a liner

! Caution

Care must be taken when installing liners such that the silicone sealer is not forced out, blocking passageways in the crankcase.

Note:

- The liners have a large chamfer at the bottom of the bore, enabling fitting of the piston without need for a piston ring compressor.

! Caution

Fit each liner over whichever piston is at TDC. When turning the engine, do not allow the pistons to contact the inside of the crankcase and also do not allow fitted liners to lift off the crankcase base.

- Continue fitting each liner in turn until all are fitted and sealed.

Note:

- When the liners have been fitted, they should not be disturbed. If it is necessary to remove the liner after fitting, the sealer must be re-applied.

6 Bevel Box and Drive Shaft

Table of Contents

| | |
|--|-----|
| Sectioned view – bevel box and drive shaft | 6.2 |
| Bevel box and drive shaft specification | 6.3 |
| Bevel box oil specification | 6.3 |
| Bevel box oil level check | 6.3 |
| Bevel box oil change | 6.4 |
| Bevel Box | 6.4 |
| Removal | 6.4 |
| Installation | 6.4 |
| Drive shaft | 6.5 |

Bevel Box and Drive Shaft

Sectioned view – bevel box and drive shaft

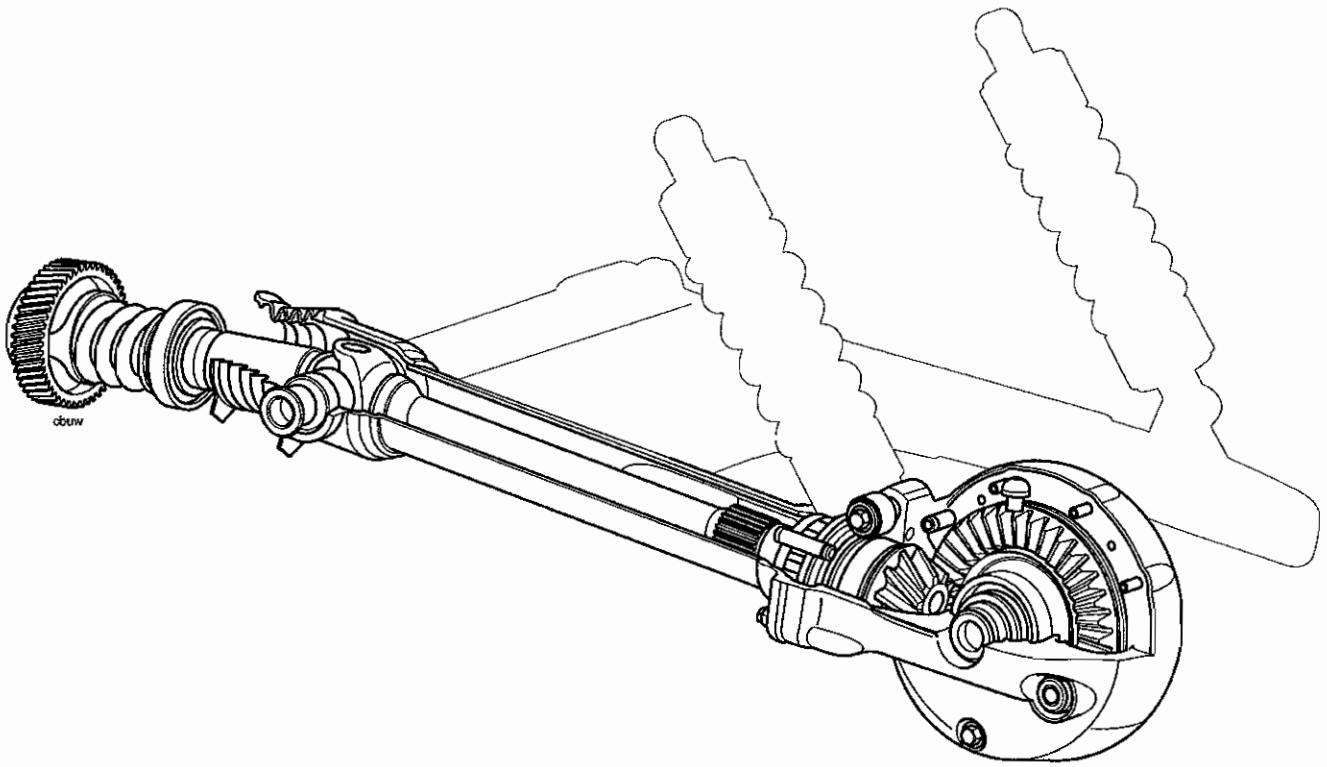

Bevel box and drive shaft specification

The Rocket III is fitted with a shaft drive coupling the transmission to the bevel box at the rear wheel. The drive shaft is fitted with a single Hookes universal joint which requires no maintenance.

The bevel box consists of a crown wheel and pinion arrangement that has no dealer serviceable parts. Maintenance consists solely of routine oil level checks and oil changes.

Warning

Under no circumstances should the final drive unit be disassembled. Failure to observe the above warning could lead to a malfunction of the final drive unit causing lock-up of the rear wheel leading to loss of motorcycle control and an accident.

Bevel box oil specification

The bevel box must be filled and topped up with Mobilube 1 SHC 75W/90 fully synthetic hypoid oil or equivalent.

Warning

Use of an incorrect bevel box lubricant could result in a malfunction of the final drive unit causing lock-up of the rear wheel leading to loss of motorcycle control and an accident.

Bevel box oil level check

Warning

Before starting work, ensure the motorcycle is stabilised and adequately supported. This will help prevent it from falling and causing injury to the operator or damage to the motorcycle.

1. Remove the filler/level plug.

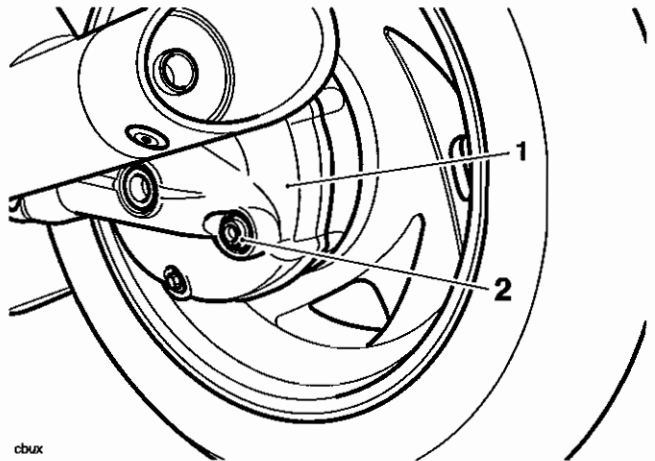

1. Bevel box
2. Filler/level plug

2. Have an assistant stand the bike upright.
3. Fill the bevel box with Mobilube 1 SHC 75W/90 fully synthetic hypoid oil (or equivalent) until the level of oil inside the unit is level with the bottom of the filler.
4. Refit the plug and tighten to 60 Nm.

Bevel Box and Drive Shaft

Bevel box oil change

Warning

Before starting work, ensure the motorcycle is stabilised and adequately supported. This will help prevent it from falling and causing injury to the operator or damage to the motorcycle.

1. Position a container beneath the bevel box drain plug.

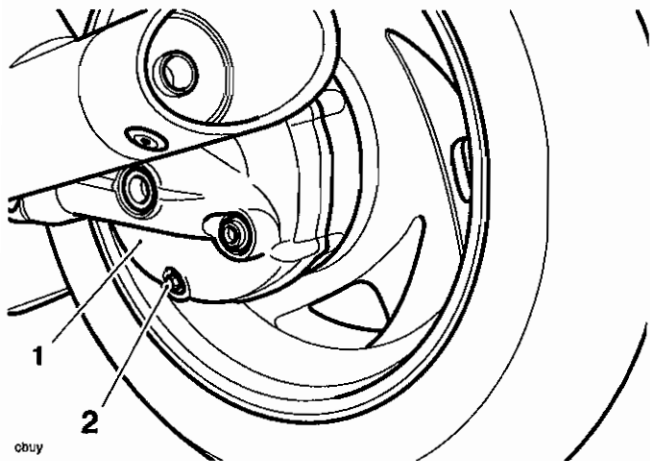

1. Bevel box
2. Drain plug

2. Remove the drain plug and allow the oil to fully drain out.
3. Wipe the drain plug clean then refit and tighten it to **15 Nm**.

Note:

- **The drain plug is magnetic. It is normal for metallic deposits to be attached to the drain plug magnet.**
4. Remove the filler plug.
 5. Have an assistant stand the bike upright during filling.
 6. Fill the bevel box with Mobilube 1 SHC 75W/90 fully synthetic hypoid oil or equivalent until the level of oil inside the unit is level with the bottom of the filler.
 7. Refit the plug and tighten to **60 Nm**.

Bevel Box

Removal

Warning

Before starting work, ensure the motorcycle is stabilised and adequately supported. This will help prevent it from falling and causing injury to the operator or damage to the motorcycle.

1. Support the motorcycle so that the rear wheel is clear of the ground.
2. Remove the rear wheel as described on page 16.8.
3. Remove the left hand rear suspension unit as described on page 13.4.
4. Release the four nuts securing the bevel box to the swinging arm.
5. Ease the bevel box towards the rear of the motorcycle, detaching the pinion coupler from the drive shaft.

Installation

Note:

- **Prior to installation, check that the drive shaft is supported by the sleeve inside the swinging arm. Rectify as necessary.**

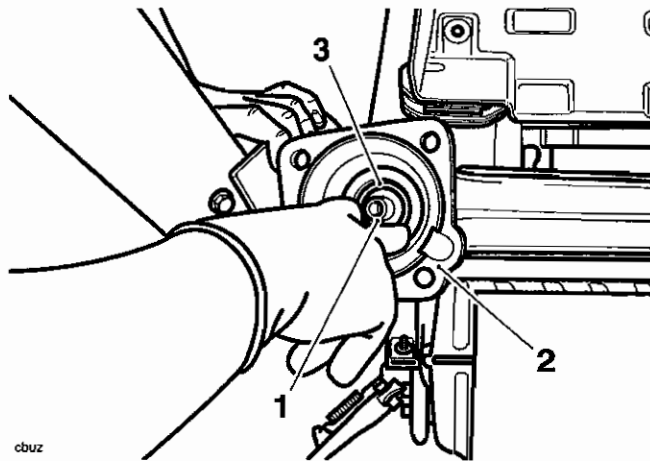

1. Drive shaft
2. Swinging arm
3. Sleeve

1. Apply a smear of Molybdenum Disulphide grease to the drive shaft splines and wheel driven flange.
2. Position the bevel box to the drive shaft engaging the pinion coupler and drive shaft at the same time.

Bevel Box and Drive Shaft

Note:

- Before tightening the bevel box nuts, fully insert the wheel spindle through the swinging arm to ensure it will realign with the swinging arm when the wheel is installed.

Note:

- Bevel box to swinging arm fixings are tightened in two stages and in a specific sequence. Tighten all fixings to the lower torque before progressing to the higher figure.

3. Align the bevel box by fully inserting the wheel spindle through the bevel box and swinging arm then, in the order shown below, tighten all the bevel box nuts to **20 Nm**, then to **64 Nm**.

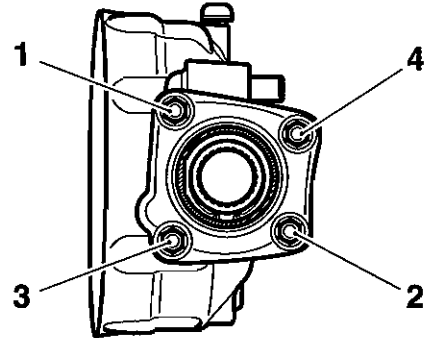

cbva

Bevel box bolt tightening sequence

4. Refit the left hand rear suspension unit as described on page 13.5.
5. Refit the rear wheel as described on page 16.9.
6. Lower the motorcycle to the ground and park it on the side stand.
7. Check and top up the bevel box oil level as described on page 6.3.

Drive shaft

Drive shaft details can be found in the rear suspension section on page 13.5.

This page intentionally left blank

7 Balancer

Table of Contents

| | |
|--------------------------------|-----|
| Exploded View - Balancer | 7-2 |
| Introduction | 7-3 |
| Removal | 7-3 |
| Inspection | 7-4 |
| Assembly/Installation | 7-4 |

Balancer

Exploded View - Balancer

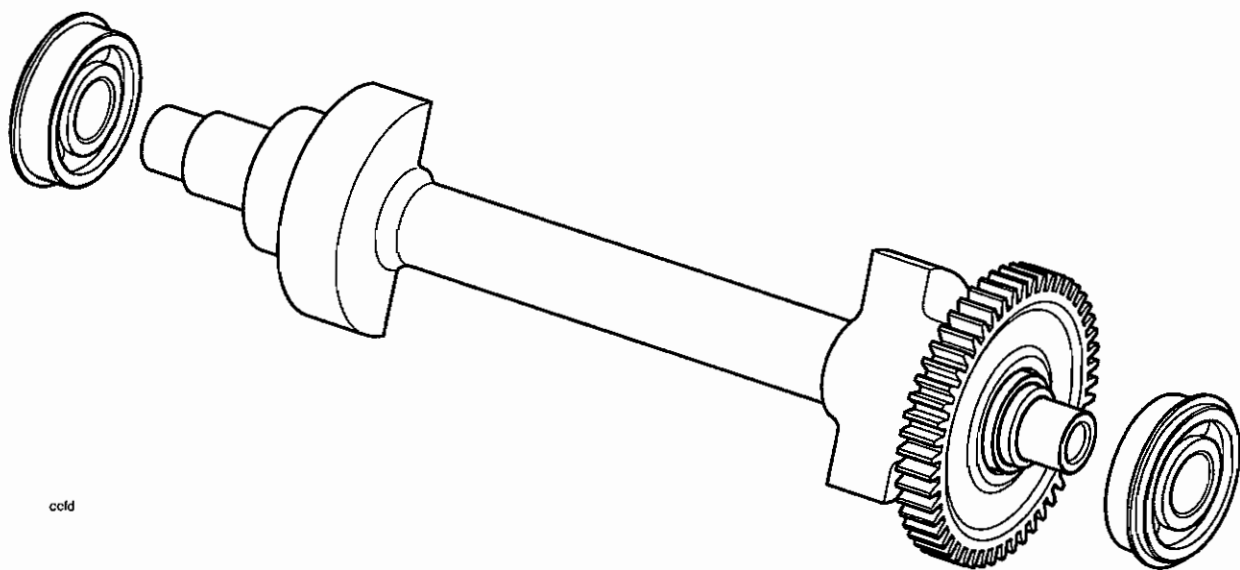

ccfd

Introduction

In an engine with an even number of cylinders (i.e. 2, 4, 6 etc.), a piston on an upward stroke is always counter-balanced by one on a descending stroke. However, in an engine with an odd number of cylinders, such as that fitted to the Rocket III, this natural state of balance does not occur. Therefore a balancer is fitted to the engine in order to control irregular pulses caused by the odd number of cylinders. Without a balancer, the engine would 'pulse' each time the crankshaft rotated. This 'pulsing' would be felt as a vibration which would amplify as engine speed increases.

The balancer has the effect of a pair of counterbalance weights, which create an equal amount of energy in the opposite direction, and at the same time as that produced by the crankshaft, pistons and connecting rods. Because the opposing pulses occur at the same point of crankshaft rotation, and are of an equal magnitude, a state of equilibrium or balance is reached.

Removal



Warning

Before starting work, ensure the motorcycle is stabilised and adequately supported. This will help prevent it from falling and causing injury to the operator or damage to the motorcycle.

1. Remove the engine as described on page 10.2.
2. Separate the crankcase halves as described on page 5.5.
3. With the crankcase halves separated, lift out the balancer shaft complete with the bearings.

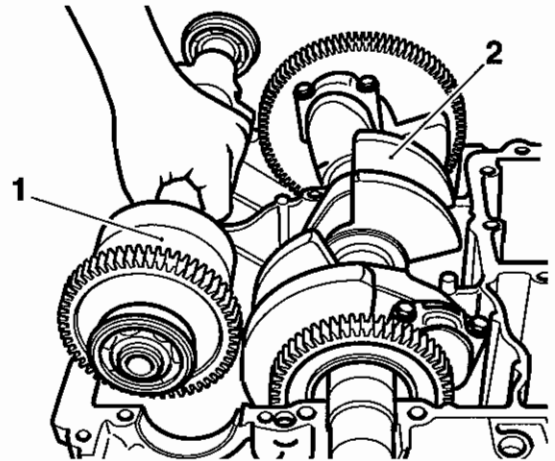

cbf

1. Balancer
2. Crankshaft

4. If necessary, slide off the ball bearing at the end opposite to the drive gear.

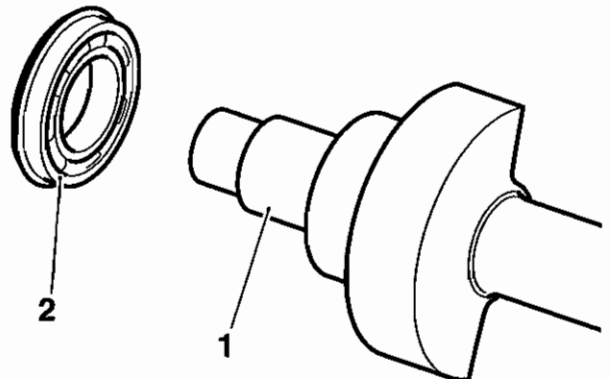

obrg

1. Balancer
2. Bearing

Note:

- The bearing at the gear end can only be removed in a press.

Balancer

Inspection

1. Inspect all gears for chipped or missing teeth and for overheating (blue discolouration).
2. Inspect all bearings for signs of overheating (blue discolouration), seizure and any other damage. Check that all bearings rotate smoothly and without tight spots.

Assembly/Installation

Note:

- Balancer shafts and crankshafts are graded. If the balancer shaft is replaced, it must be grade-matched with the crankshaft. For identification, both are marked adjacent to the alignment dots (see note below) either 'A' or 'B'. Always match an 'A' grade crankshaft with an 'A' grade balancer shaft and vice-versa.

Note:

- A 'B' grade component does not indicate inferior quality to an 'A' grade component.

Note:

- To ensure a correct relationship, the balancer must be installed in a specific orientation relative to the crankshaft. There are dot marks, one on the balancer drive gear (on the crankshaft) and one on the balancer driven gear, which must be in alignment when the balancer shaft is fitted.

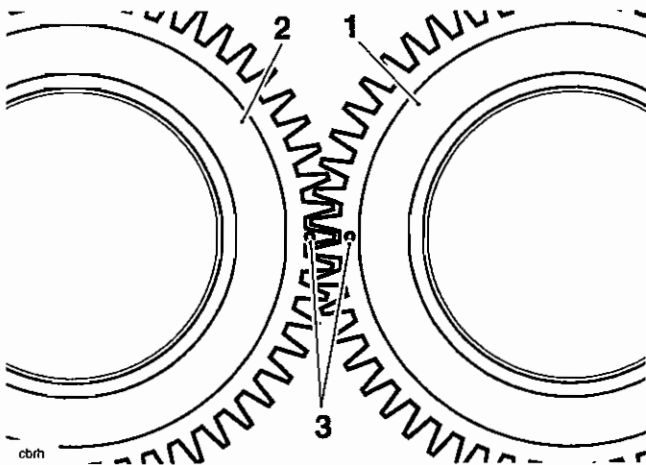

1. Balancer drive gear
2. Balancer driven gear
3. Dot marks

Note:

- A further alignment check can be made if required. When number one cylinder in the engine is on top-dead-centre (TDC), slots on the end of the balancer will align with the split line of the crankcase. This allows a balancer installation check on an installed engine by removing only the clutch cover.

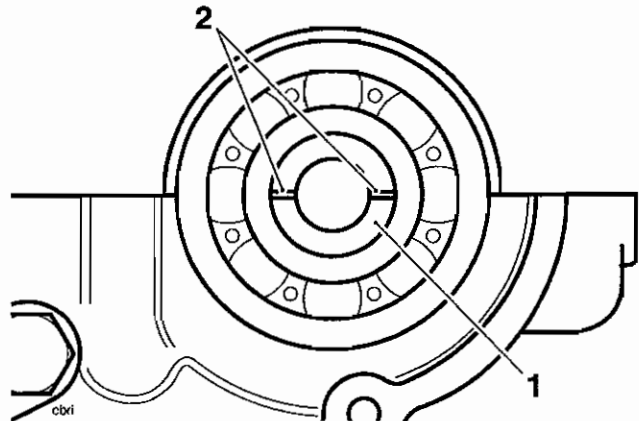

1. Balancer shaft
2. Slot marks

1. Position the balancer to the upper crankcase aligning the dot marks as shown below.

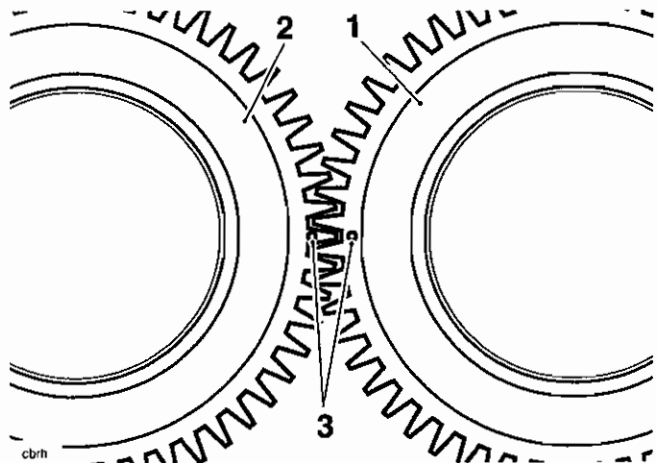

1. Balancer drive gear
2. Balancer driven gear
3. Dot marks

2. Position the balancer bearings such that the dowel pegs locate in slots in the upper crankcase.

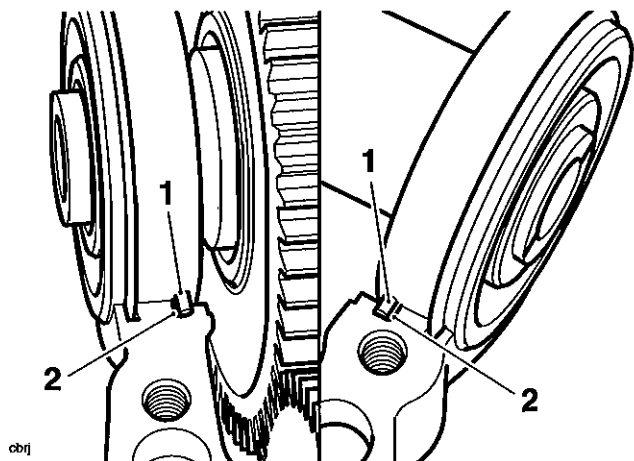

1. Bearing dowels
2. Upper crankcase slots

3. Ensure the circlips fitted to the balancer bearings locate and seat correctly in corresponding grooves, also in the upper crankcase.

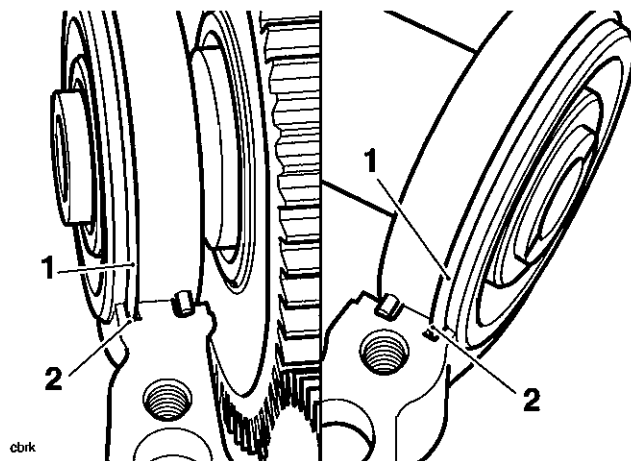

1. Circlips
2. Grooves
4. Check that the balancer and crank dot marks are still in alignment.
5. Assemble the crankcase halves as described on page 5.7.
6. Refit the engine to the frame as described on page 10.5.

This page intentionally left blank

8 Transmission

Table of Contents

| | |
|--|------|
| Exploded View - Input and Output Shafts | 8-2 |
| Exploded View - Gear Change Mechanism | 8-3 |
| Exploded View - Gear Selector Mechanism | 8-4 |
| Exploded View - Torsional Damper Shaft Housing | 8-5 |
| Exploded View - Torsional Damper Shaft | 8-6 |
| Selector Shaft, Selector Forks and Drum | 8-7 |
| Removal | 8-7 |
| Inspection | 8-9 |
| Installation | 8-9 |
| Torsional Damper Shaft | 8-11 |
| Removal | 8-11 |
| Installation | 8-12 |
| Input and Output Shaft Assemblies | 8-12 |
| Removal | 8-12 |
| Installation | 8-13 |
| Output Shaft | 8-14 |
| Disassembly | 8-15 |
| Inspection | 8-15 |
| Assembly | 8-16 |
| Input Shaft | 8-18 |
| Disassembly | 8-19 |
| Inspection | 8-20 |
| Assembly | 8-20 |

Transmission

Exploded View - Input and Output Shafts

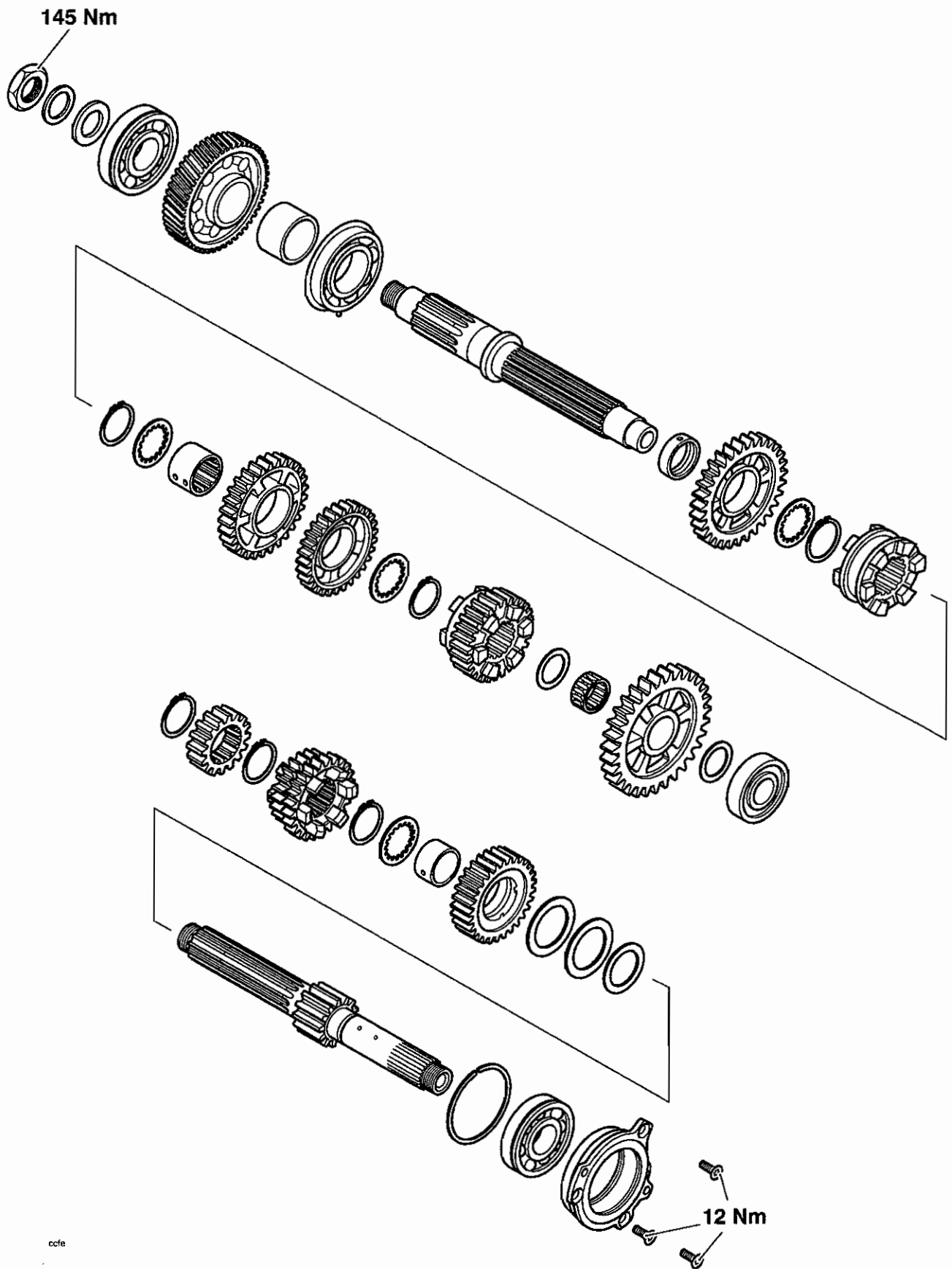

Exploded View - Gear Change Mechanism

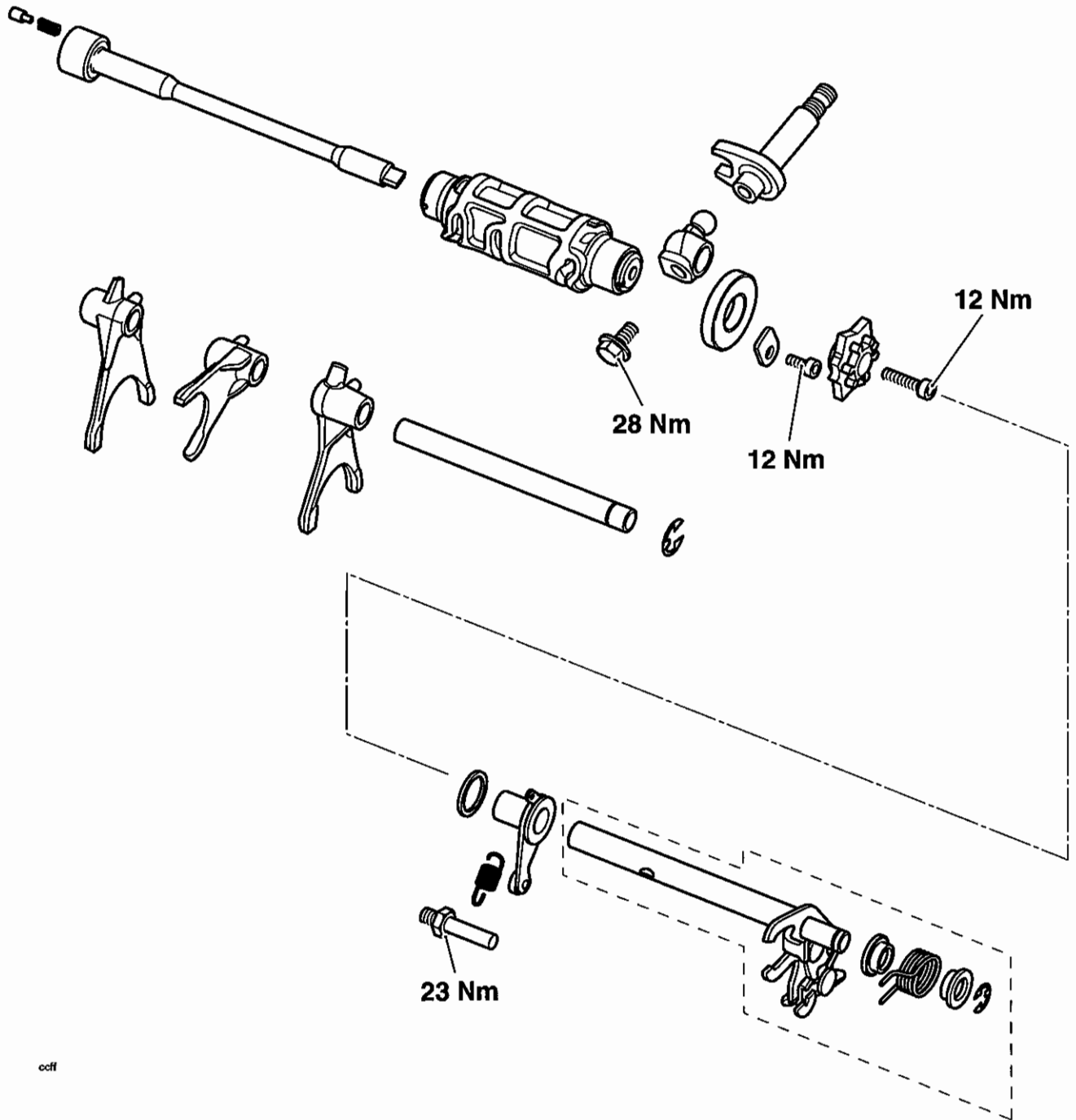

coff

Transmission

Exploded View - Gear Selector Mechanism

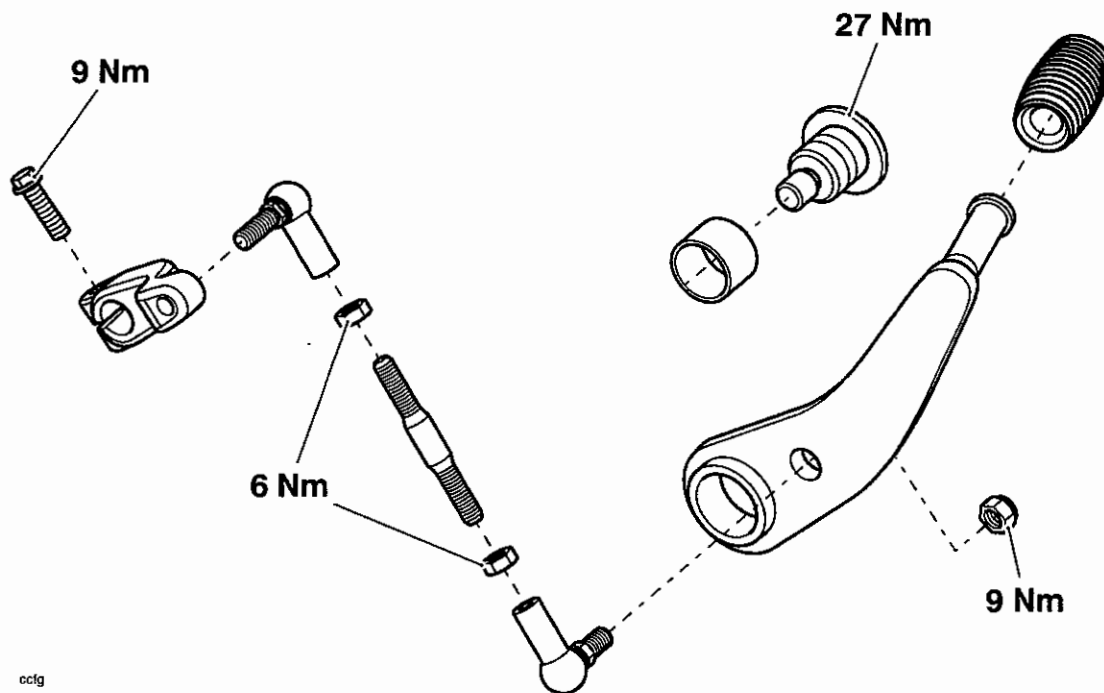

ccfg

Exploded View - Torsional Damper Shaft Housing

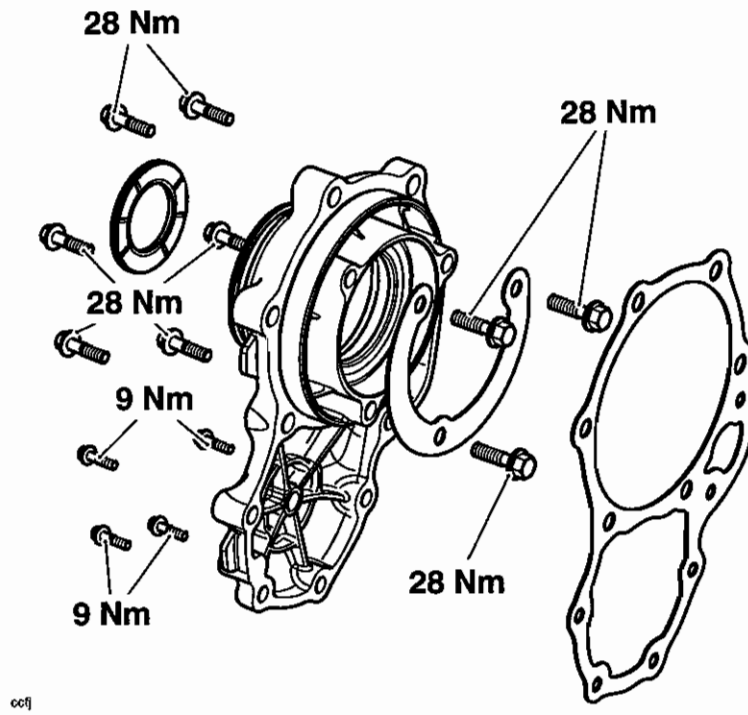

Transmission

Exploded View - Torsional Damper Shaft

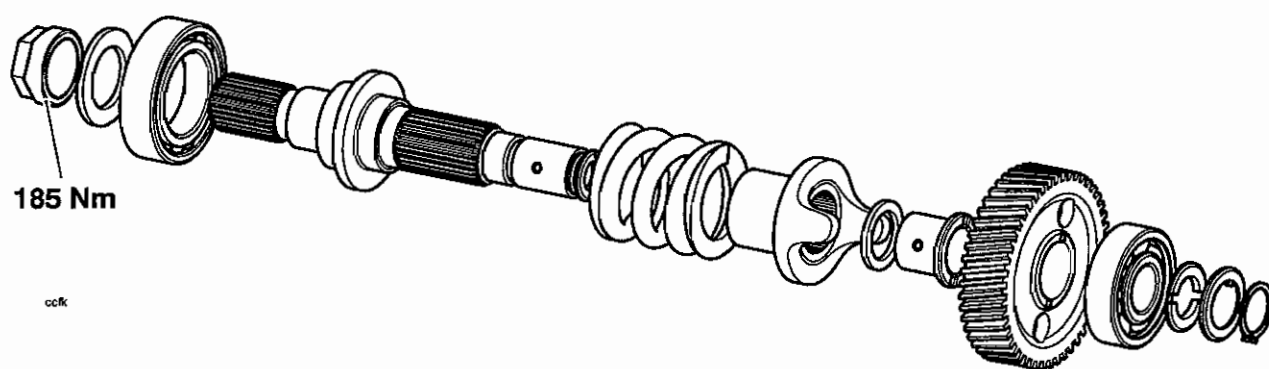

Selector Shaft, Selector Forks and Drum

Removal

Note:

- Prior to removal, mark, or make a note of the relative positions of each selector fork in the selector drum.

1. Remove the engine from the frame as described on page 10.2.
2. Separate the lower crankcase from the upper as described on page 5.5.
3. Remove the output shaft from the crankcase.
4. Remove the 'C' clip from the selector shaft.

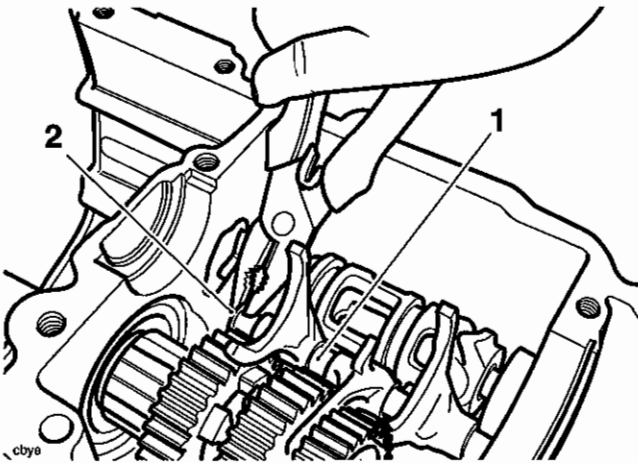

1. Selector shaft
2. 'C' clip

5. Insert an M6 bolt, hand tight only, into the thread at the front end of the selector shaft.

6. Pulling on the inserted bolt, ease the selector shaft out from the crankcase, collecting each selector fork as the exiting shaft releases them.

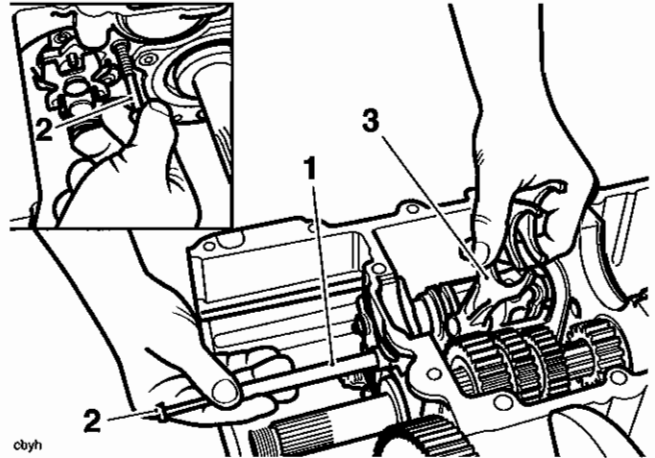

1. Selector shaft
2. Bolt
3. Selector forks

7. Remove the input shaft as described on page 8.12.
8. Remove the bolt securing the gear change actuator arm to the gear change shaft.

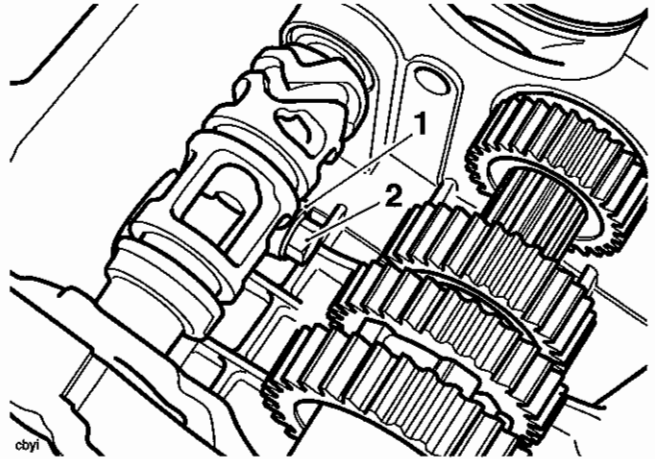

1. Gear change actuator arm
2. Bolt

Note:

- Removal of the gear change shaft will detach the gear change actuator arm as the shaft slides out. Collect the actuator from inside the crankcase as soon as it is released. In addition, the detent spring will also become detached from the spring abutment bolt.

Transmission

9. Slide the gear change shaft out of the crankcase, collecting the gear change actuator arm and detent spring at the same time.

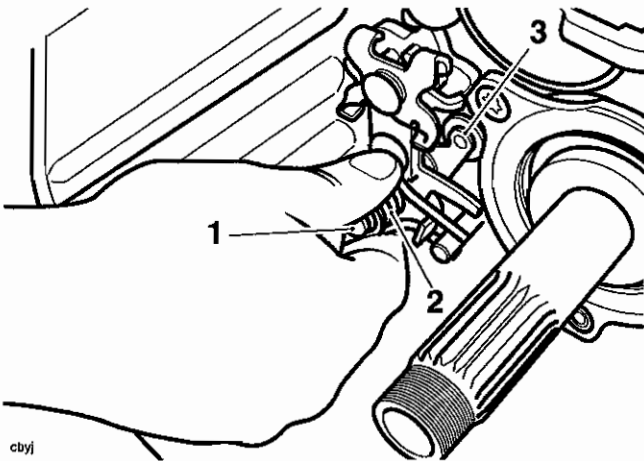

1. Gear change shaft
2. Gear change actuator arm
3. Detent arm

10. Insert a soft-faced implement through the selector drum to prevent it from turning, and then undo the screw securing the detent wheel to the selector drum.

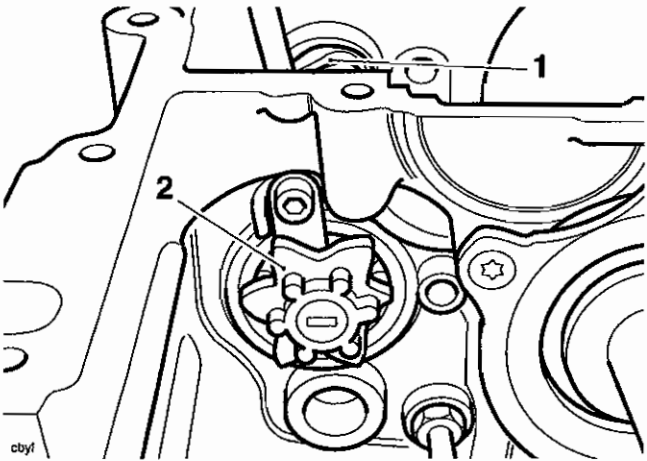

1. Selector drum
2. Detent wheel

11. Release the small screw securing the selector drum, bearing and keeper plate to the crankcase.

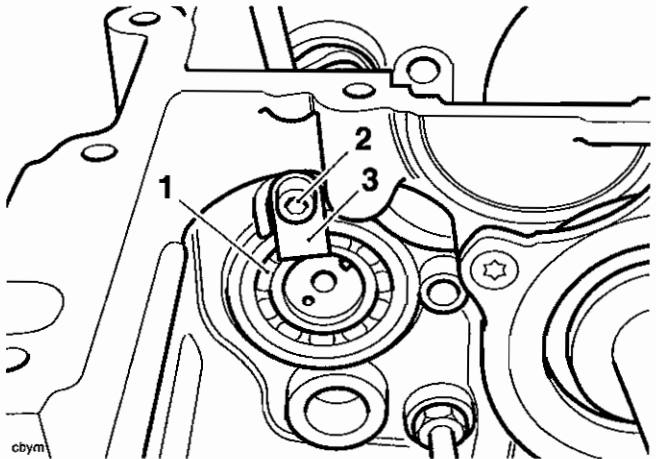

1. Selector drum bearing
2. Screw
3. Keeper plate

12. Pull/push the selector drum out and in to dislodge the bearing, then remove the drum from the crankcase.
13. To remove the actuator shaft, slide it inwards and recover it from inside the crankcase.

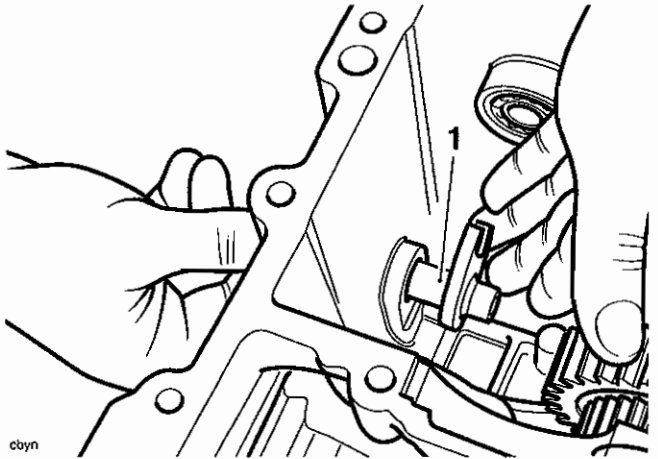

1. Actuator shaft

Note:

- It is not normally necessary to remove the inner selector drum bearing, though it is possible to do so by drifting from behind its recess in the crankcase.

14. If necessary, remove the spring abutment bolt.

Inspection

1. Inspect all springs for over-extension (i.e. abnormal gaps between coils). Replace as necessary.
2. Inspect all seals for damage and distortion. Renew as necessary.
3. Check the selector forks and selector grooves for wear beyond the service limits. Renew components as necessary.

| Item | Standard | Service Limit |
|--------------------------|----------------|---------------|
| Selector fork thickness | 5.90 – 6.00 mm | 5.80 mm |
| Selector groove width | 6.05 – 6.15 mm | 6.30 mm |
| Fork to groove clearance | 0.05 – 0.25 mm | 0.50 mm |

Installation

1. Refit the actuator shaft; ensuring it is pushed fully home in the crankcase.
2. Locate the selector drum to the crankcase and engage it in the inner bearing.

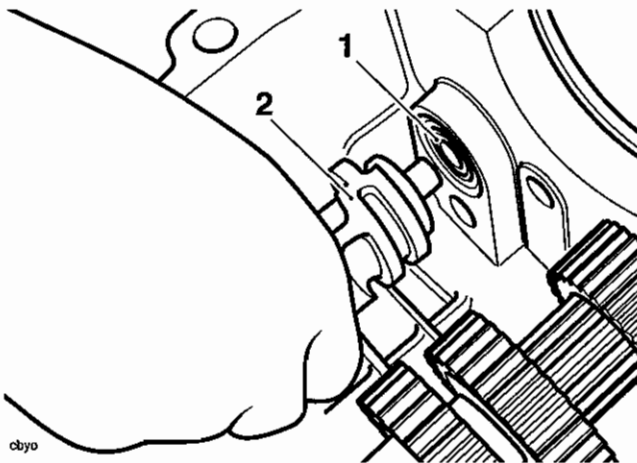

1. Inner bearing
2. Selector drum
3. Fit the selector drum outer bearing, bearing keeper plate and retain the plate using a new screw. Tighten the screw to **12 Nm**.
4. Apply Loctite 1305 to the threads of the spring abutment bolt (if removed). Fit and tighten it to **23 Nm**.

5. Position the detent wheel to the selector drum, engaging the pin on the drum with the corresponding recess in the rear of the wheel.

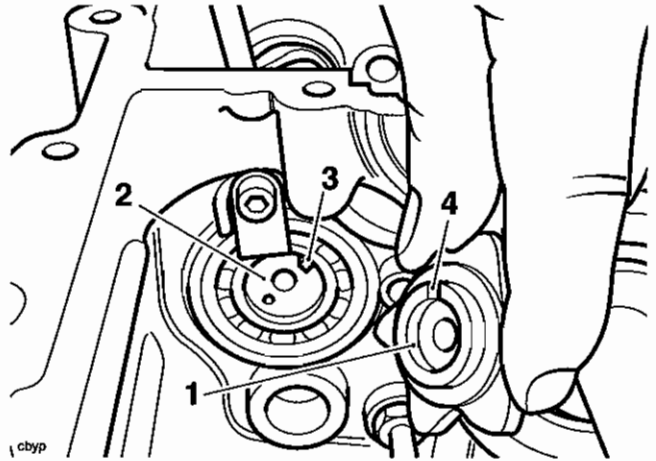

1. Detent wheel
2. Selector Drum
3. Pin
4. Recess

6. Fit a new screw to the detent wheel, prevent the drum from turning using a soft-faced tool, then tighten the screw to **12 Nm**.
7. Slide the detent arm and spring onto the gear change shaft, with the spring eye end of the detent arm entering the shaft first.

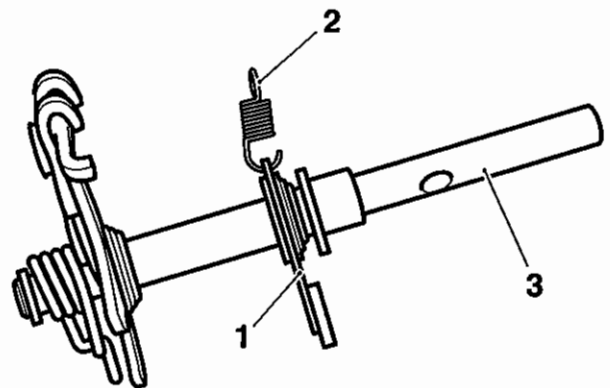

1. Detent arm
2. Spring eye
3. Shaft
8. Position the assembly to the crankcase and part engage it in its hole.
9. Locate and hold the ball-end of the gear change actuator arm in the actuator.

Transmission

10. Feed the gear change shaft through the crankcase, engaging it in the actuator arm and also attaching the free end of the detent arm spring over the spring abutment bolt. Ensure that the gear change return spring also engages over the spring abutment bolt.

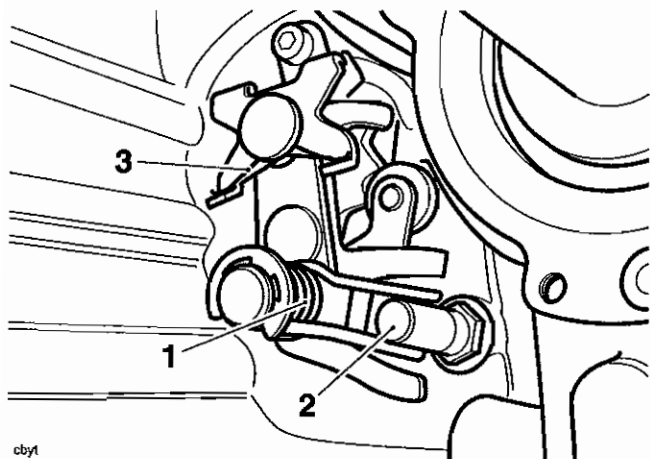

1. Detent arm spring
2. Spring abutment bolt
3. Gear change return spring

11. Fit a new bolt to the gear change actuator and tighten it to 28 Nm.

Note:

- If a new bolt cannot be sourced, clean the threads of the old bolt and apply a spot of three-bond 1305 to the threads before fitting it.

12. Refit the input shaft as described on page 8.13.

Note:

- Selector forks are marked A, B and C. The marking letters always face the clutch end of the input shaft.

13. Place the transmission in neutral. The transmission is in neutral when the wheel of the detent arm rests in a tooth on the detent wheel that has a V-shaped cut-out.

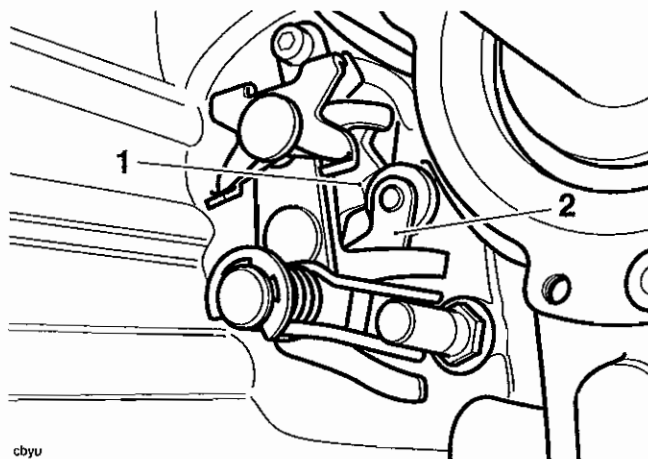

1. V-shaped cut out
2. Detent arm

14. Partially insert the selector shaft into the crankcase.

15. Position and support the selector forks in the selector drum as noted or marked prior to removal.

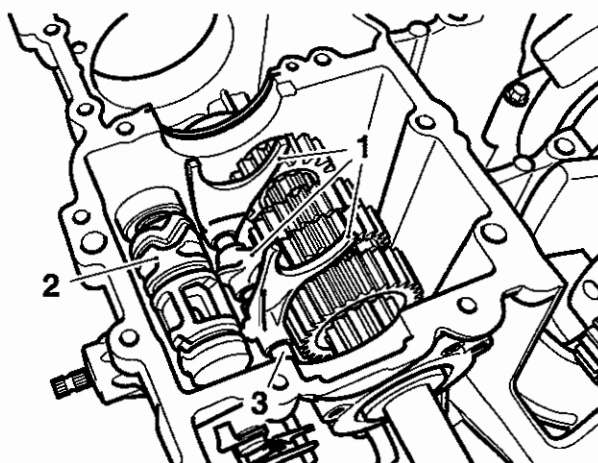

1. Selector forks
2. Selector drum
3. Selector shaft

16. Feed the selector shaft through the selector forks and secure it with a new 'C' clip.

17. Assemble the crankcases as described on page 5.7.

18. Refit the engine as described on page 10.5.

Torsional Damper Shaft

Removal

1. Remove the engine from the frame (see page 10.2).
2. Remove the fixings securing the gear position sensor to the torsional damper shaft housing.
3. Withdraw the sensor and collect its O-ring.

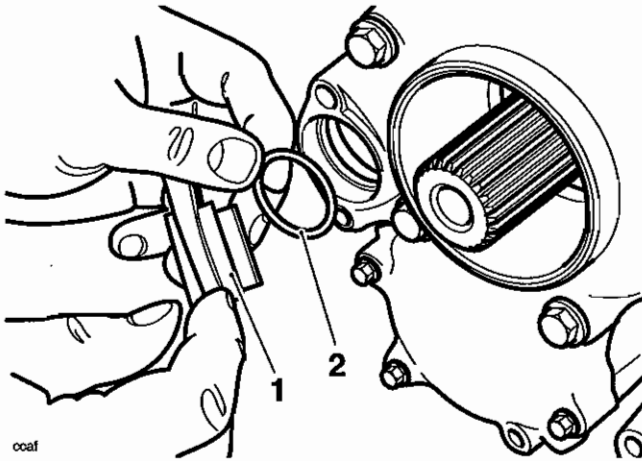

1. Gear position sensor
2. O-ring

4. Release the bolts securing the damper shaft housing to the crankcases.

! Caution

The torsional damper shaft assembly is often a tight fit in the crankcase. Never level or force implements between the crankcase and housing as this will damage both components. Gently use a soft-faced mallet to ease the components apart.

5. Withdraw the damper shaft assembly.

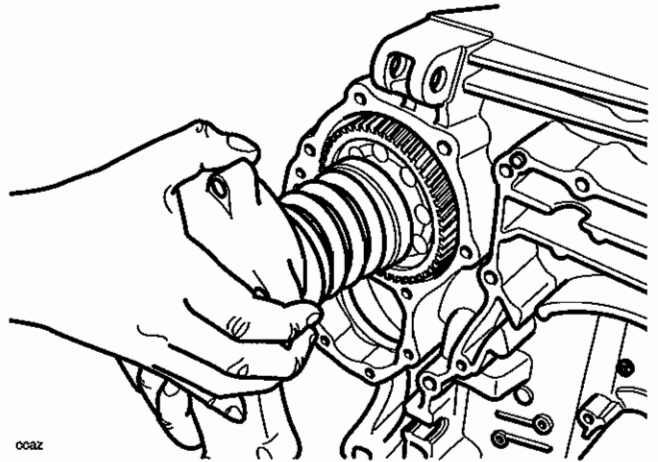

6. Collect the gear position indicator shaft from inside the crankcase, taking care to not drop the spring and plunger from its outer end.

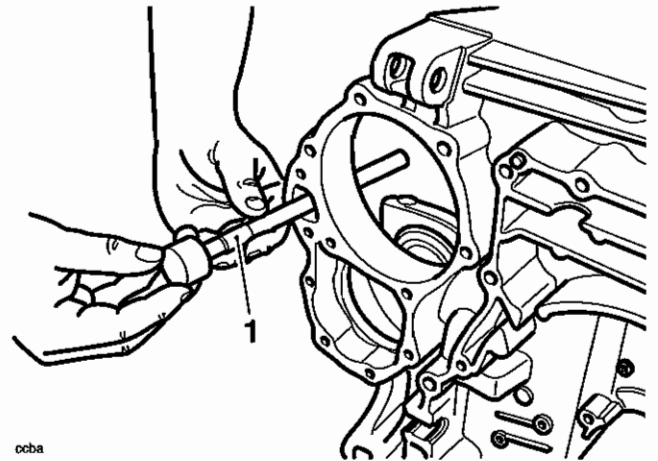

1. Gear position indicator shaft

Transmission

Installation

1. Place a new torsional damper shaft housing gasket over the crankcase.

Note:

- **The gear position indicator shaft can also be fitted after installing the torsional damper shaft housing.**
2. Install the gear position indicator shaft, engaging the inner drive slot with the selector drum.
 3. Locate the damper assembly to the crankcases and push fully home, engaging the meshing gears as you do so.
 4. Fit and tighten the damper housing bolts to **28 Nm**.
 5. Fit a new O-ring to the gear position sensor. Lubricate the O-ring with petroleum jelly.
 6. Fit the gear position sensor and tighten its fixings to **9 Nm**.

Input and Output Shaft Assemblies

Removal

Note:

- **The input and output shafts may be removed from the upper crankcase after first separating the lower crankcase from the upper.**

Note:

- **The rear bearing on the input shaft remains in the crankcase on removal of the shaft.**

1. Remove the engine from the frame as described on page 10.2.
2. Separate the lower crankcase from the upper as described on page 5.5.

Note:

- **The output shaft may be retained in the lower crankcase on separation from the upper. If the output shaft is not retained in the lower crankcase, make a note of the position of each selector fork on the output shaft.**
3. Lift the output shaft from the upper crankcase noting the orientation of each bearing and their circlips.
 4. Remove the selector shaft and forks as described on page 8.7.

Note:

- **The input shaft bearing housing fixings may not be reused but should be retained for use during installation of the input shaft.**

- Release the three Torx fixings securing the input shaft bearing housing to the upper crankcase.

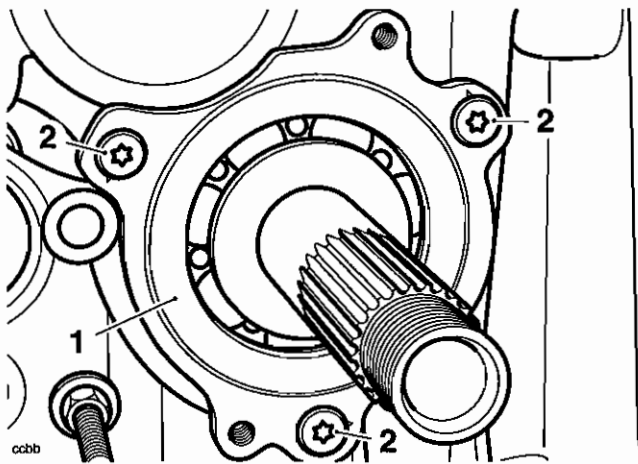

- Input shaft bearing housing
- Torx fixings

- Insert two M6 bolts into the two threaded holes at the periphery of the bearing housing. Evenly and progressively tighten both bolts to draw the bearing housing from the crankcase.

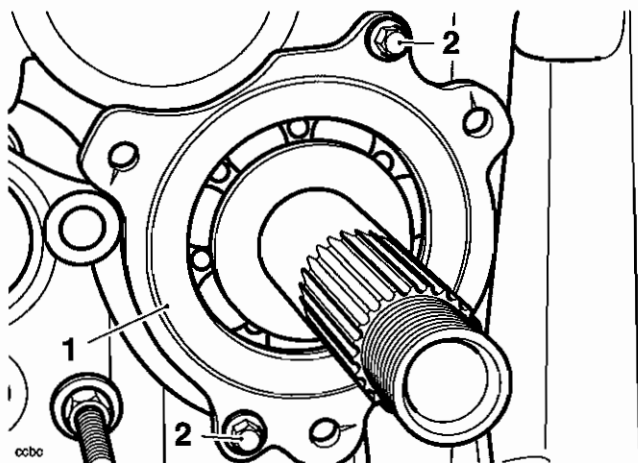

- M6 bolts
- Bearing housing

- With the bearing housing released, withdraw the input shaft through the aperture for the bearing housing.

Installation

- Locate the input shaft to the upper crankcase, installing it through the aperture for the bearing housing.
- Fit the bearing housing into the aperture, by hand, as deeply as possible.
- Using the old Torx fixings, draw the bearing housing into the upper crankcase until fully home. Remove and discard the Torx fixings.

- Fit new Torx fixings to the bearing housing. Tighten them to **12 Nm**.
- Using a small punch, stake the Torx heads to the corresponding notches in the upper crankcase.

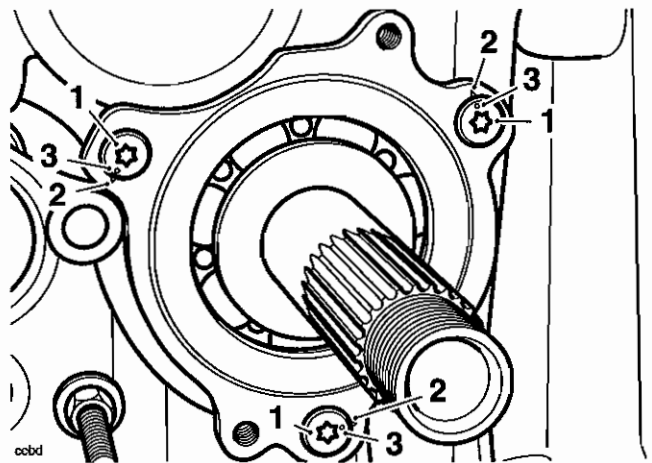

- Torx fixings
- Notches
- Stake marks

- Refit the selectors and shaft as described on page 8.9.
- Refit the output shaft to the crankcase ensuring the snap-ring on the outside of the inner bearing locates in their corresponding groove in the crankcase.

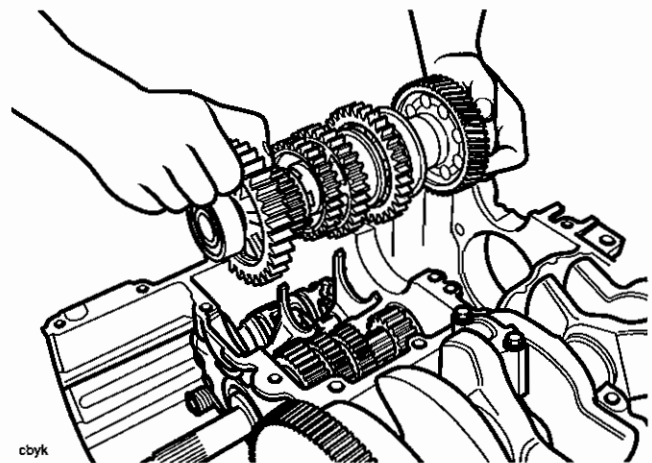

Installing the Output Shaft

- Assemble the crankcases as described on page 5.9.
- Refit the engine to the frame as described on page 10.5.

Transmission

Output Shaft

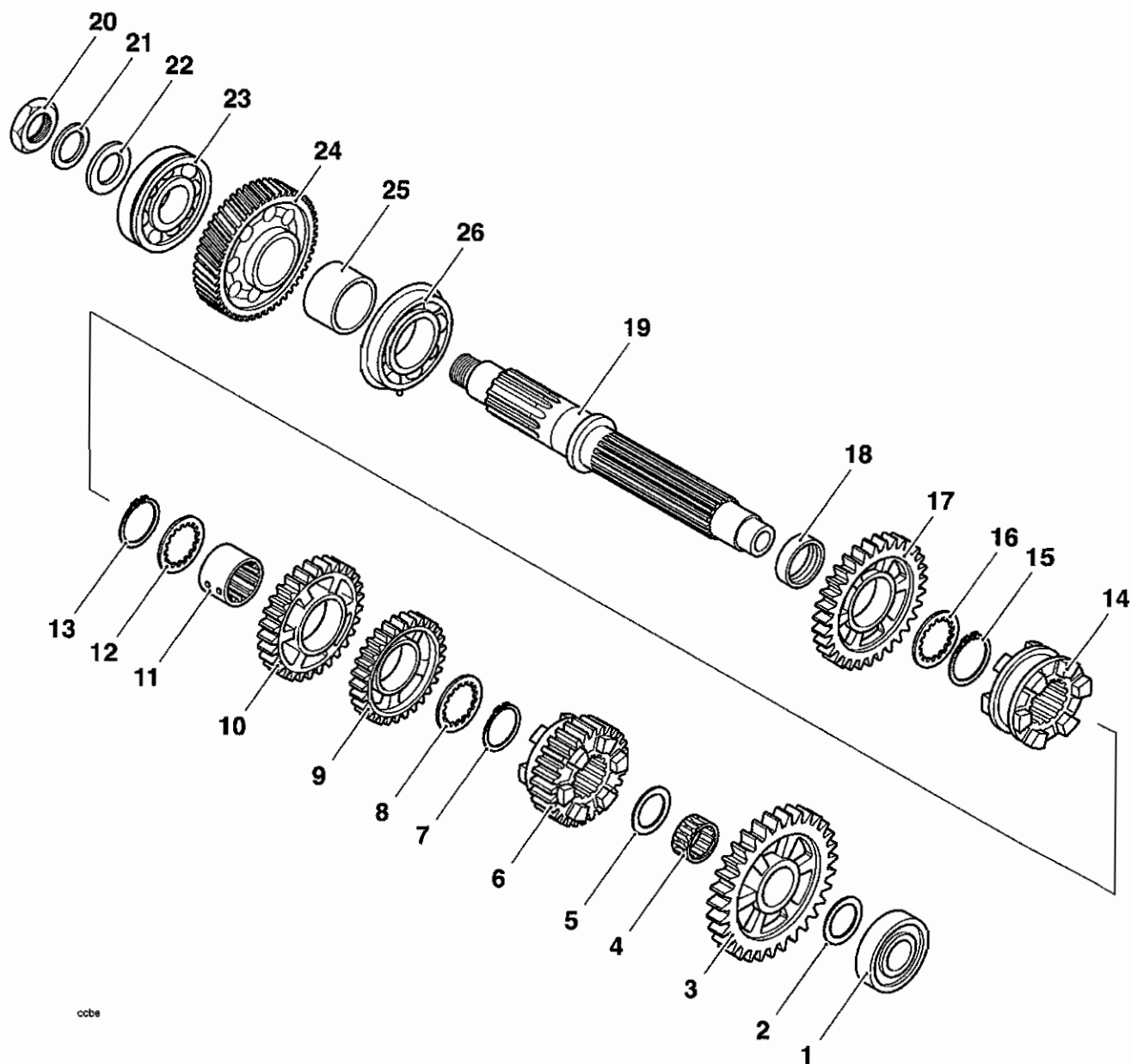

ccbe

1. Ball bearing
2. Thrust washer
3. First gear
4. Needle roller bearing
5. Thrust washer
6. Fifth gear
7. Circlip
8. Thrust washer
9. Fourth gear
10. Third gear
11. Splined bush
12. Thrust washer
13. Circlip

14. Dog ring
15. Circlip
16. Thrust washer
17. Second gear
18. Second gear bush
19. Output shaft
20. Nut
21. 'C' washer
22. Flat washer
23. Ball bearing
24. Output gear
25. Spacer
26. Ball bearing

Disassembly

Note:

- All numbers given within brackets in the procedure below, refer directly to the numbered items in the above diagram.

Make a note or mark the orientation of all parts prior to removal.

1. Remove the ball bearing (1) and washer (2).
2. Remove first gear (3) and its needle roller bearing (4).
3. Remove the first gear thrust washer (5).
4. Remove fifth gear (6), revealing a circlip (7) that secures fourth and third gears.
5. Remove the circlip (7).
6. Slide off the thrust washer (8) from in front of fourth gear (9), then slide off fourth gear.
7. Slide off third gear (10), the splined third/fourth gear bush (11) and the thrust washer (12).
8. Remove the circlip (13) from in front of the splined dog ring (14).
9. Slide off the splined dog ring (14).
10. Remove the circlip (15) from in front of second gear (17).
11. Slide off the second gear thrust washer (16), then second gear (17) and its bush (18).
12. Working now from the other end of the shaft, remove the large nut (20) Bellville washer (21) and flat washer (22).
13. Slide off the ball bearing (23), output gear (24) and spacer (25).

Never wear loose clothing, which could become trapped in the press and cause crushing injury to the hand, arms or other parts of the anatomy.

14. Place the shaft (19) in a press with the threaded end of the shaft facing the press ram. Support the centre bearing (26) on press bars.

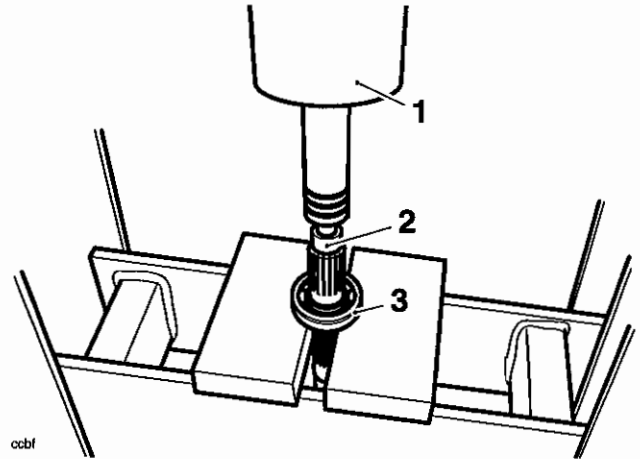

1. Press
2. Output shaft
3. Centre bearing

15. Press the shaft through the bearing.

Inspection

1. Examine all gears, bearings and bushes and thrust washers for damage, distortion, chipped teeth and wear beyond the service limits. Replace all suspect components and always use new circlips to assemble the shaft.

 **Warning**

When using a press, always wear overalls, eye face and hand protection. Objects such as bearings frequently break-up under load and the debris caused during break-up may cause damage and injury to unprotected parts of the body.

Transmission

Assembly

Note:

- Lubricate each gear, thrust washer and bush with clean engine oil during assembly.

Note:

- The circlips used on the output shaft have a flat side and an angled side. Illustrations throughout the assembly text indicate which orientation of each circlip is correct.



Caution

Bushes with oil holes must always be **MISALIGNED** with the corresponding oil holes in the output shaft. Reduced oil pressure and gear lubrication may result from alignment of the oil holes, which would cause premature wear of engine and transmission components.



Warning

When using a press, always wear overalls, eye face and hand protection. Objects such as bearings frequently break-up under load and the debris caused during break-up may cause damage and injury to unprotected parts of the body.

Never wear loose clothing, which could become trapped in the press and cause crushing injury to the hand, arms or other parts of the anatomy.

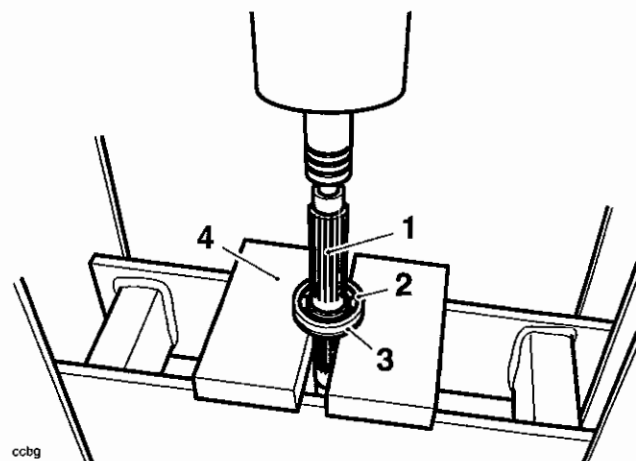

1. Output shaft
2. Bearing
3. Circlip groove
4. Press bars

2. Locate the output shaft (19) to the bearing, with the threaded end pointing through the bearing (i.e. away from the press).
3. Press the output shaft through the bearing until the shoulder in the centre of the shaft contacts the bearing face.
4. Fit the spacer (25) to the shaft, then slide on the output gear (24).
5. Fit the bearing (24) to the shaft and retain with the flat washer (22), Bellville washer (21) and nut (20). Tighten the nut to **145 Nm**.
6. Working from the other end of the shaft, slide on the second gear bush (18).

1. Place the centre output shaft bearing (26) on press bars, ensuring that the press bars support the inner race of the bearing and the circlip groove on the outer race is nearest to the press bars.

7. Fit second gear (17) and thrust washer (16).
8. Fit a new circlip (15), orientating the circlip as shown below.

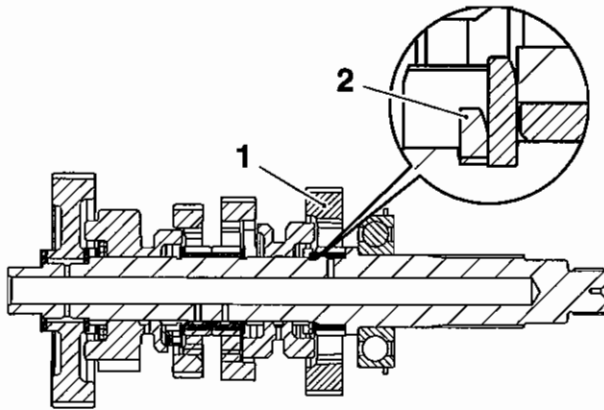

ccbh

1. Second gear
2. Circlip

9. Fit the splined dog ring (14) to the shaft.
10. Retain the dog ring with a new circlip (13), orientating the circlip as shown below.

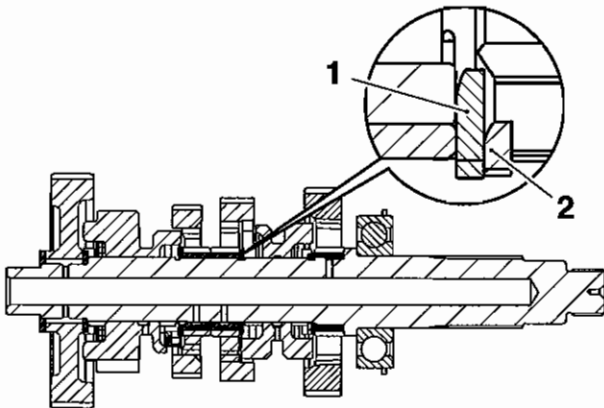

ccbi

1. Dog ring
2. Circlip

11. Fit the thrust washer (12) and splined bush (11).
12. Slide third and fourth gears (10 and 9) onto the splined bush.

13. Fit the thrust washer (8), then a new circlip (7), orientating the circlip as shown below.

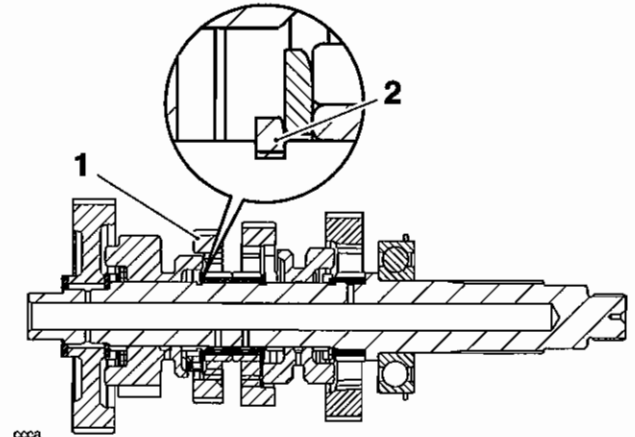

ccca

1. Third/fourth gear
2. Circlip

14. Fit fifth gear (6) to the shaft, followed by the thrust washer (5).
15. To complete assembly of the output shaft, fit the needle roller bearing (4), first gear (3), thrust washer (2) and bearing (1).

Transmission

Input Shaft

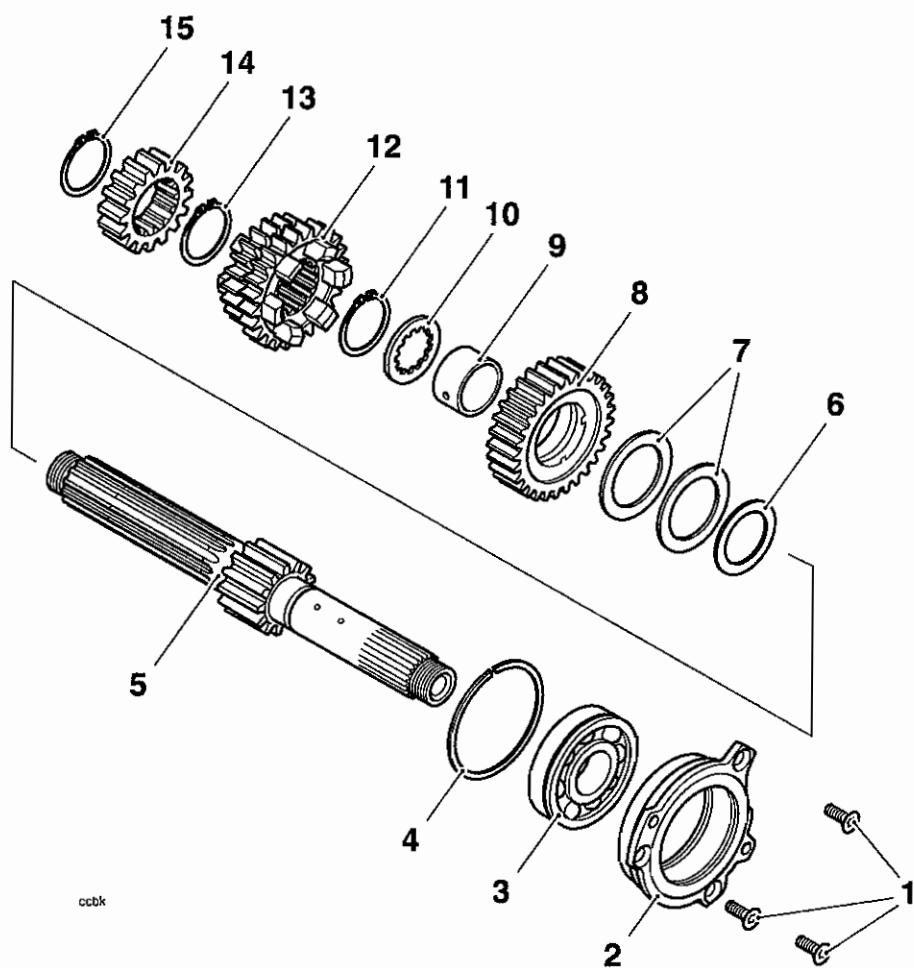

ccb

- 1. Torx screws
- 2. Bearing retainer plate
- 3. Ball bearing
- 4. Retaining ring
- 5. Input shaft
- 6. Thrust washer
- 7. Belleville washers

- 8. Fifth gear
- 9. Fifth gear bush
- 10. Thrust washer
- 11. Circlip
- 12. Third/fourth gear
- 13. Circlip
- 14. Second gear
- 15. Circlip

Disassembly

1. Remove the circlip (15) from in front of second gear (14).
2. Remove second gear (14).
3. Remove the circlip (13) from in front of third/fourth gear (12).
4. Remove third/fourth gear (12).
5. Remove the circlip (11) from in front of fifth gear (8).
6. Remove the thrust washer (10), fifth gear (8) and the fifth gear bush (9).
7. Note (or mark) the orientation of the two Belleville washers (7), then remove them from the shaft.
8. Remove the thrust washer (6).

Note:

- **Unless the bearing at the clutch end of the input shaft is damaged or worn, it is not normally necessary to remove it from the shaft. The bearing is pressed onto the shaft and is also pressed into its housing and retained by a snap-ring. The bearing and housing are removed from the shaft together and are then separated.**

9. Support the bearing and housing on press bars, then press the shaft through the bearing and housing as shown below.

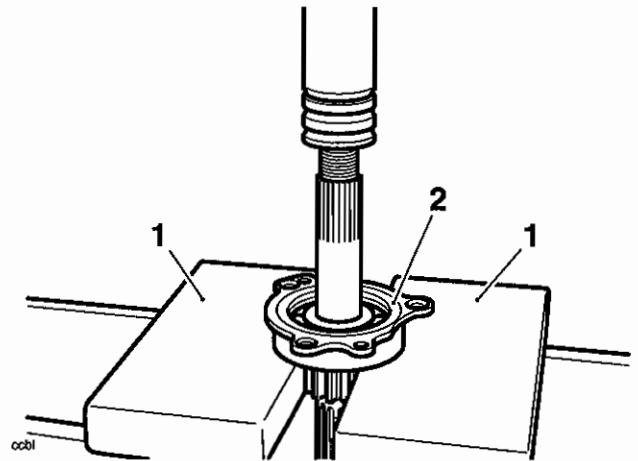

1. Press bars
2. Bearing/housing

10. Remove the snap-ring from the bearing housing.

Caution

When pressing the bearing out of the housing, never support the housing on its peripheral lugs, as they will break under the loads imparted by the press. Always support the housing on its outer circumference ensuring the maximum arc of that circumference is supported.

11. Support the outer circumference of the bearing housing on press bars, then press the bearing through the housing.

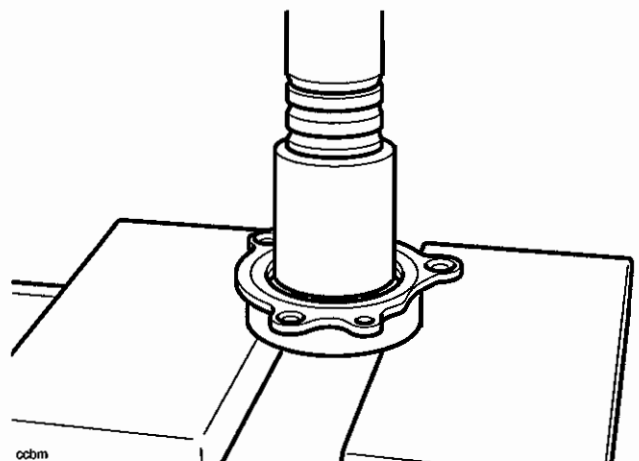

Pressing out the bearing

 **Warning**

When using a press, always wear overalls, eye face and hand protection. Objects such as bearings frequently break-up under load and the debris caused during break-up may cause damage and injury to unprotected parts of the body.

Never wear loose clothing, which could become trapped in the press and cause crushing injury to the hand, arms or other parts of the anatomy.

Transmission

Inspection

1. Examine all gears, bearings and bushes and thrust washers for damage, distortion, chipped teeth and wear beyond the service limits. Replace all defective components and always use new circlips to assemble the shaft.
2. Thoroughly clean the bearing housing and inspect for damage, scoring and cracks. Replace the housing if necessary

Assembly

Note:

- Lubricate each gear, thrust washer and bush with clean engine oil during assembly.

Note:

- The circlips used on the input shaft have a flat side and an angled side. Illustrations throughout the assembly text indicate which orientation of each circlip is correct.

Warning

When using a press, always wear overalls, eye face and hand protection. Objects such as bearings frequently break-up under load and the debris caused during break-up may cause damage and injury to unprotected parts of the body.

Never wear loose clothing, which could become trapped in the press and cause crushing injury to the hand, arms or other parts of the anatomy.

Caution

Bushes with oil holes must always be **MISALIGNED** with the corresponding oil holes in the output shaft. Reduced oil pressure and gear lubrication may result from alignment of the oil holes, which would cause premature wear of engine and transmission components.

Caution

Removing the input shaft bearing from the shaft and its housing will damage the bearing and snap ring. Never re-use removed bearings or snap rings as use of damaged or weakened components could lead to engine and transmission damage. Also, check for damage to the housing itself.

1. Position a new bearing to the housing.

Caution

Press only on the bearing outer race to prevent bearing damage.

2. Support the housing on press bars as shown below and press the bearing fully into the housing in the direction of the arrow.

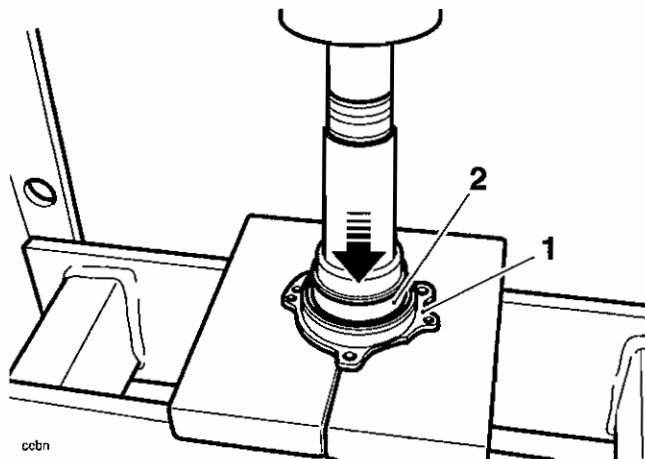

1. Bearing housing

2. Bearing

3. Retain the bearing with a new snap ring.

Caution

Press only on the bearing inner race to prevent bearing damage.

4. Locate the bearing and housing to the input shaft. Support the shaft on the press bed and press the bearing onto the shaft.

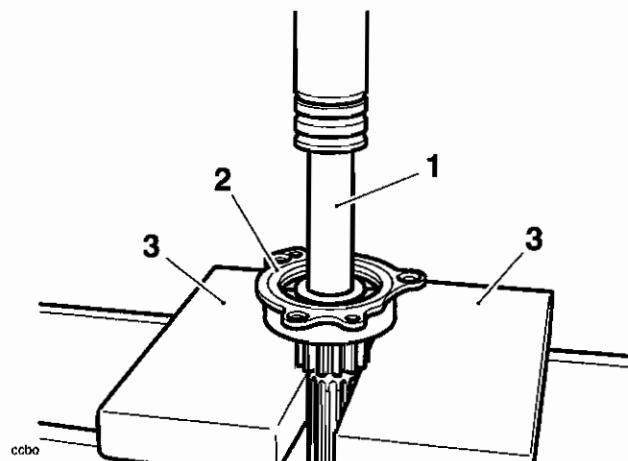

1. Shaft

2. Bearing/housing

3. Press bars

5. Working now on the opposite end to the bearing, slide on the thrust washer (6).

6. Fit the bush (9).
7. Fit the Belleville washers (7) over the bush, arranging them as shown below.

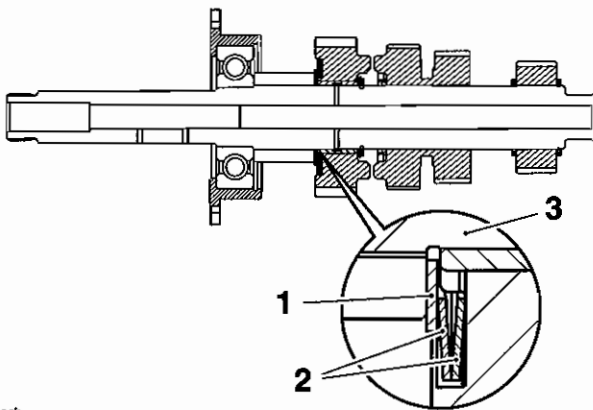

ccb

1. Thrust washer
2. Belleville washers
3. Bush

8. Fit fifth gear (8) and the fifth gear thrust washer (10).
9. Retain the assembly with a new circlip (11), orientating the circlip as shown below.

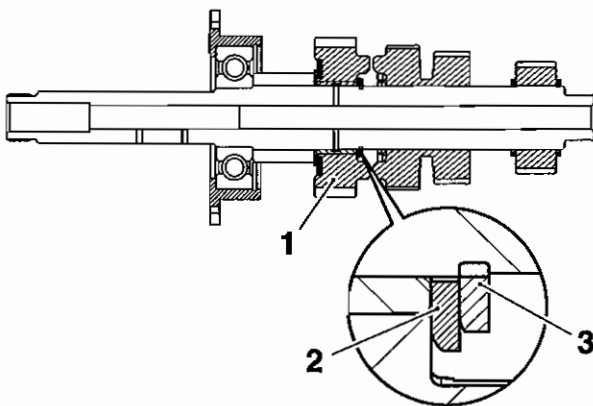

ccb

1. Fifth gear
2. Fifth gear thrust washer
3. Circlip

10. Fit the third/fourth gear (12) to the shaft.

11. Retain third/fourth gear with a new circlip (13), orientating the circlip as shown below.

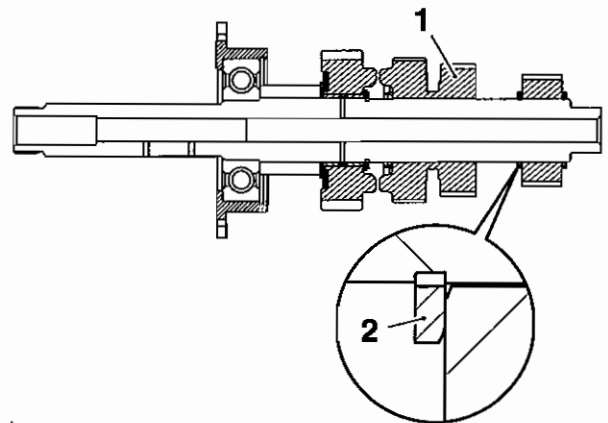

ccbq

1. Third/fourth gear
2. Circlip

12. Slide on second gear (14).

13. Retain second gear with a new circlip (13), orientating the circlip as shown below.

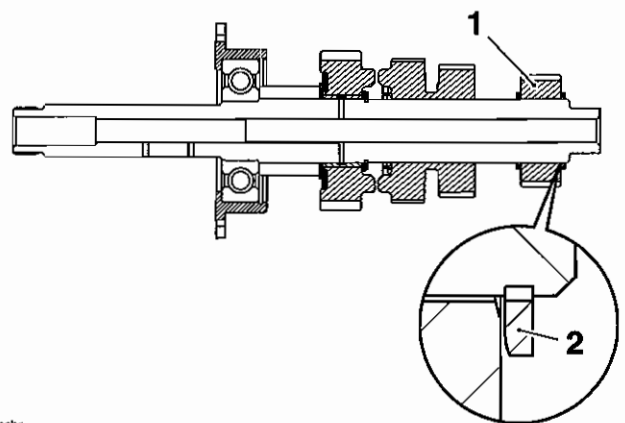

ccbr

1. Second gear
2. Circlip

This page intentionally left blank

9 Lubrication

Table of Contents

| | |
|---|------|
| Exploded View – Sump | 9-2 |
| Exploded View – Oil tank, filter and pumps | 9-3 |
| Oil Circuit | 9-4 |
| General Description | 9-4 |
| Scavenge System | 9-4 |
| Pressure System | 9-4 |
| Engine Oil | 9-6 |
| Specification | 9-6 |
| Triumph Engine Oil | 9-6 |
| Oil Level Inspection | 9-6 |
| Oil and Oil Filter Change | 9-7 |
| Disposal of Used Engine Oil and Oil Filters | 9-8 |
| Low Oil Pressure Warning Light Switch | 9-9 |
| Removal | 9-9 |
| Installation | 9-10 |
| Sump | 9-10 |
| Removal | 9-10 |
| Inspection | 9-10 |
| Installation | 9-11 |
| Oil Pumps | 9-11 |
| Removal | 9-11 |
| Inspection | 9-13 |
| Installation | 9-14 |
| Oil Non-Return Valve | 9-15 |
| Oil Pressure Relief Valve | 9-15 |
| Oil Tank | 9-16 |
| Removal | 9-16 |
| Inspection | 9-16 |
| Installation | 9-16 |
| Oil Transfer Pipes | 9-16 |

Lubrication

Exploded View – Sump

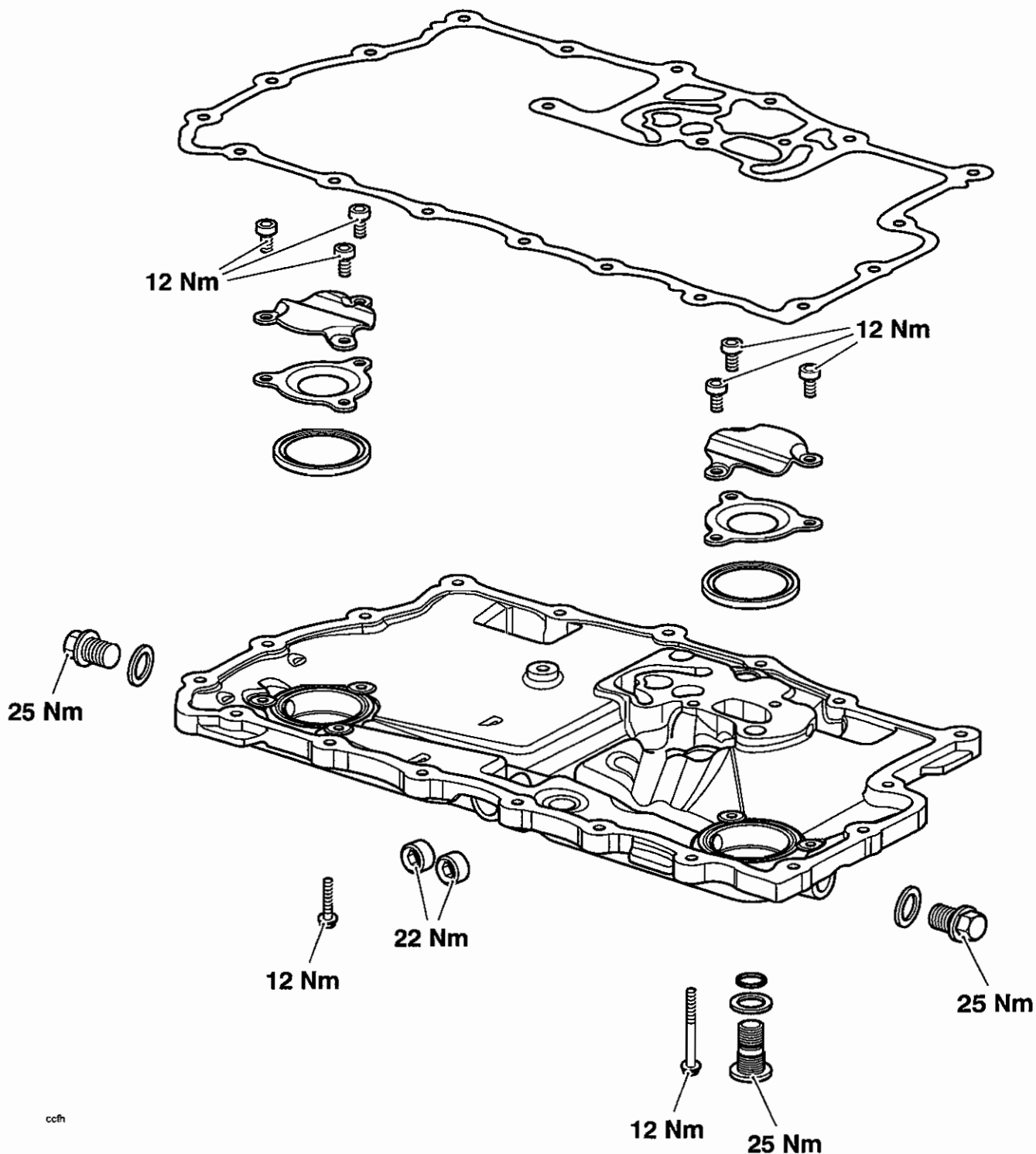

Exploded View – Oil tank, filter and pumps

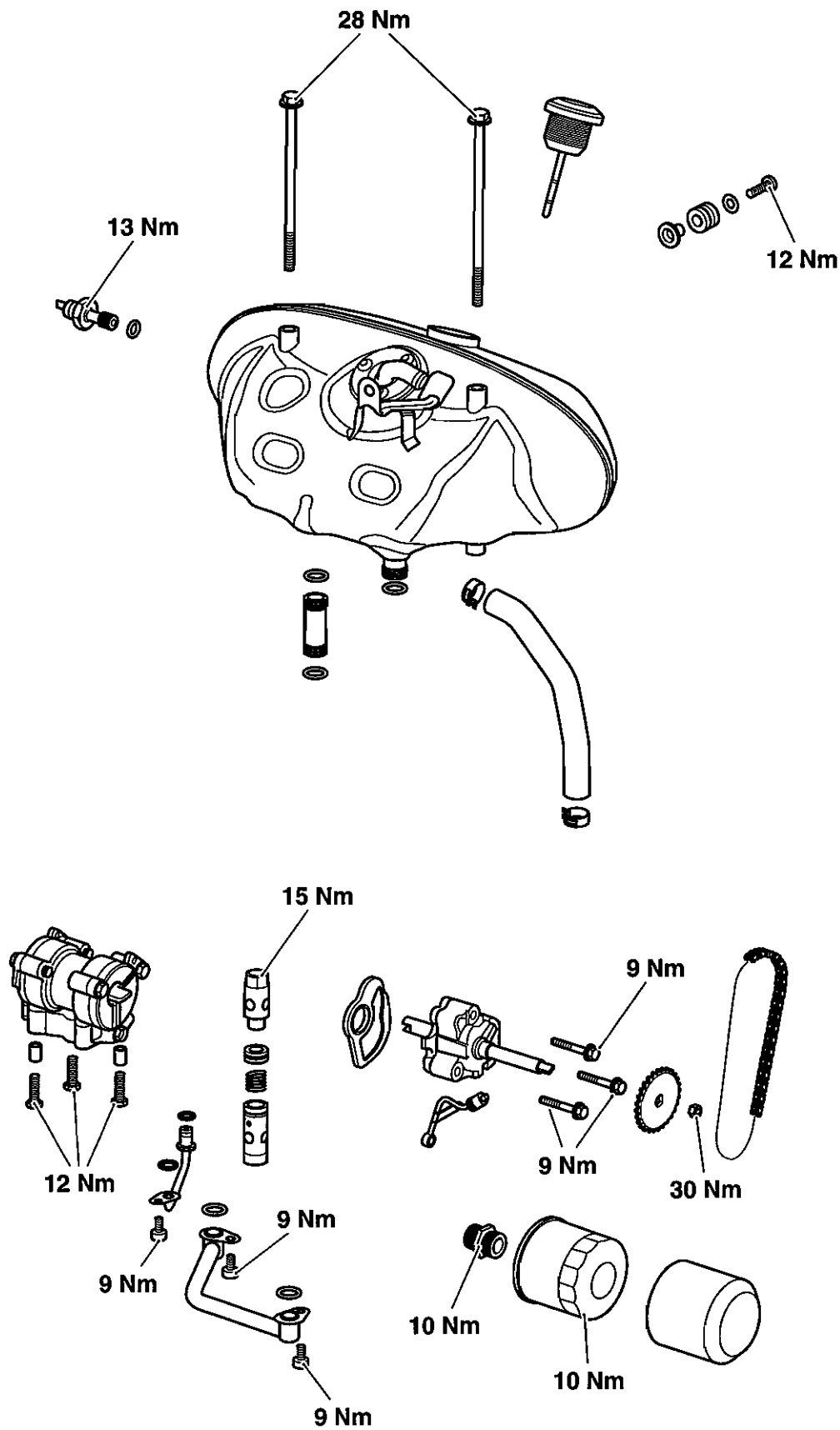

oefh

Lubrication

Oil Circuit

General Description

The Rocket III utilises a dry sump lubrication system whereby a pressure pump takes oil from an oil tank and delivers oil under pressure to the engine and transmission. A scavenge pump collects oil from the sump and returns it to the oil tank.

The oil tank is attached to the upper crankcase on the left hand side of the motorcycle. Situated within the lower crankcase, the pressure pump is gravity fed from the oil tank via an internal drilling. An oil tank drain plug is situated at the lowest point in the drilling, in the sump itself.

Scavenge System

Pickups from the double-ended scavenge pump collect oil from the front and rear of the sump and return it to the oil tank. Further drain plugs are fitted to the front and rear of the sump to drain residual oil from the sump.

Pressure System

From the pressure pump, the oil is delivered along an internal passage, past the oil pressure relief valve. The oil pressure relief valve relieves excess oil pressure by allowing oil to return to the sump. Once past the oil pressure relief valve, the pressurised oil goes through a one-way valve whose purpose is to prevent the oil in the tank from draining into the lower crankcase area.

From the one-way valve, the oil is passed through the oil filter. Filtered oil is fed directly to the main oil gallery for distribution. Drillings from the main oil gallery feed oil to the four crankshaft main bearings. There are also three piston oil jets, located in the main bearing housings which lubricate and cool the pistons.

Oil is also fed from the main oil gallery, through internal drillings and pipes, to the transmission. The transmission input shaft is both drilled through its entire length and cross-drilled. The cross drillings provide oil directly to the gears, selector forks and bearings. Oil flowing through the centre of the shaft exits at the clutch end, to provide oil to the clutch assembly. A spray jet for the outside of the clutch is mounted directly to the pressure pump. The torsional damper shaft is also fed from the input shaft. The torsional damper shaft is cross-drilled to feed the gears, bushes and other running surfaces. An internal passageway carries oil to the output shaft bearing and then on to the output shaft. The output shaft is also cross-drilled to carry oil to the gears, selector forks and bearings.

The cylinder head is fed via an internal drilling coming from number 4 main bearing. Within the cylinder head, a passageway through the cam ladder feeds oil to the camshaft bearings, and spills oil onto the tappet buckets and the valves. Spill oil returns via the cam chain area to the sump, lubricating the cam chain in the process. Also located off the cylinder head supply is an oil jet which cools the alternator. The low oil pressure warning switch is located at the rear of the cylinder head.

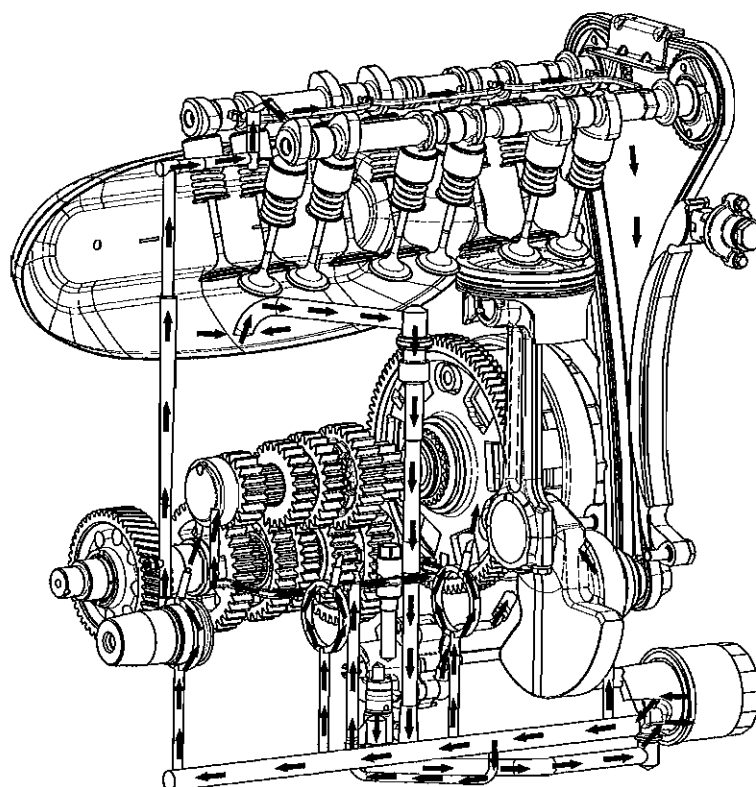

PRESSURE SYSTEM

ccdk

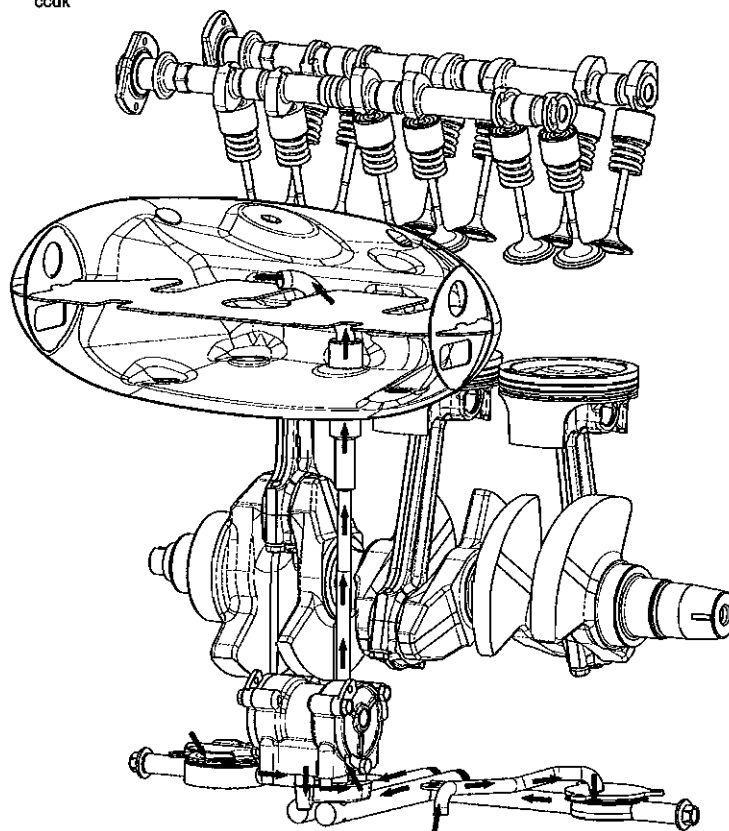

SCAVENGE SYSTEM

Lubrication

Engine Oil

Specification

Use a semi or fully synthetic 10W/40 or 15W/50 motorcycle engine oil which meets specification API SH (or higher) and JASO MA, such as Mobil 1 Racing 4T (fully synthetic) or Mobil Extra 4T (semi synthetic).

! Caution

Triumph high performance fuel injected engines are designed to use semi or fully synthetic motorcycle engine oil that meet specification API SH (or higher) AND JASO MA.

Do not add any chemical additives to the engine oil. The engine oil also lubricates the clutch and any additives could cause the clutch to slip.

Do not use mineral, vegetable, non-detergent oil, castor based oils or any oil not conforming to the required specification. The use of these oils may cause instant, severe engine damage.

Ensure no foreign matter enters the oil tank during an oil change or top-up.

Triumph Engine Oil

Your Triumph Motorcycle is a high-quality product which has been carefully built and tested to exacting standards. Triumph Motorcycles are keen to ensure that you enjoy optimum performance from your machine and with this objective in mind have tested many of the engine lubricants currently available to the limits of their performance.

Mobil 1 Racing 4T consistently performed well during our tests and has become our primary recommendation for the lubrication of all current Triumph motorcycle engines.

Mobil 1 Racing 4T, specially filled for Triumph, is available from your authorised Triumph dealer.

Oil Level Inspection

In order for the engine, transmission, and clutch to function correctly, maintain the engine oil at the correct level, and change the oil and oil filter in accordance with scheduled maintenance requirements.

! Warning

Motorcycle operation with insufficient, deteriorated, or contaminated engine oil will cause accelerated engine wear and may result in engine or transmission seizure. Seizure of the engine or transmission may lead to sudden loss of control and an accident.

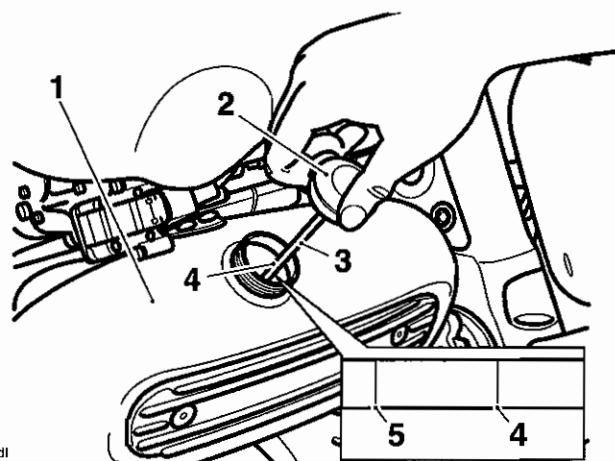

1. Oil tank
2. Oil tank cap
3. Dipstick
4. Maximum mark
5. Minimum mark

! Caution

Ensure no foreign matter or contamination enters the oil tank during an oil change or top-up. Contamination entering the oil tank may lead to engine damage.

1. Allow the engine to idle for one minute, then stop the engine.
2. Remove the filler cap/dipstick from the oil tank, wipe the dipstick clean and refit the filler cap, pushing it fully home.

Note:

- The actual level is indicated when the motorcycle is upright, (not on the side stand) and when the filler cap/dipstick has been pushed fully home.
3. Remove the filler cap/dipstick.

4. The maximum oil level is indicated by marks on the filler cap/dipstick. When the oil level is correct, the indicated oil level must be between the maximum and minimum lines on the dipstick.
5. If the oil level is too low, add oil a little at a time until the correct level is reached.
6. Once the correct level is reached, fit the filler cap/dipstick.

Oil and Oil Filter Change

The engine oil and filter must be replaced in accordance with scheduled maintenance requirements. Because this motorcycle has a dry-sump lubrication system, the oil change procedure differs from those many will be familiar with. This is because the majority of the oil is contained in the oil tank on the left side of the engine, not in the sump. To change the engine oil and filter, follow the instructions below/over.

Warning

Prolonged or repeated contact with engine oil can lead to skin dryness, irritation and dermatitis. In addition, used engine oil contains harmful contamination that can lead to skin cancer. Always wear suitable protective clothing and avoid skin contact with used oil.

Allow the engine to idle briefly, then stop the engine and secure the motorcycle in an upright position.

1. Place an oil drain pan beneath the engine.

Warning

The oil and filter may be hot to the touch. Contact with hot oil may cause the skin to be scalded or burned.

2. Remove the oil tank drain plug from the bottom of the sump and allow the oil tank to drain.

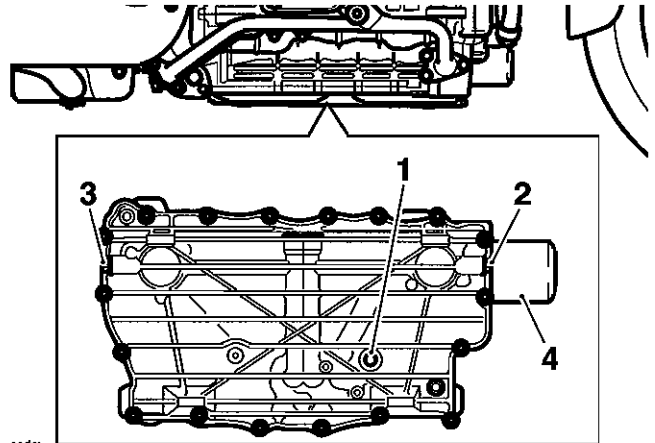

1. Oil tank drain plug
2. Front sump drain plug
3. Rear sump drain plug
4. Oil filter cover

Note:

- **Removal of the oil tank drain plug allows the oil to drain from the oil tank, not the sump. In order to drain the one or two litres of oil left in the sump, the front and rear sump plugs must also be removed.**
3. Incorporating a new washer, refit the oil tank drain plug, tightening it to **25 Nm**.
 4. Position the oil drain pan towards the front of the engine, remove the front sump drain plug and allow the oil to drain. This will drain the oil remaining in the front part of the sump.
 5. Incorporating a new washer, refit the front sump plug, tightening it to **25 Nm**.
 6. Position the oil drain pan towards the rear of the engine, remove the rear sump plug and allow the remaining oil to drain. This will drain any oil remaining in the rear part of the sump.
 7. Incorporating a new washer, refit the rear sump plug. Tighten to **25 Nm**.

Lubrication

- Remove the oil filter cover by pulling it gently towards the front of the motorcycle.

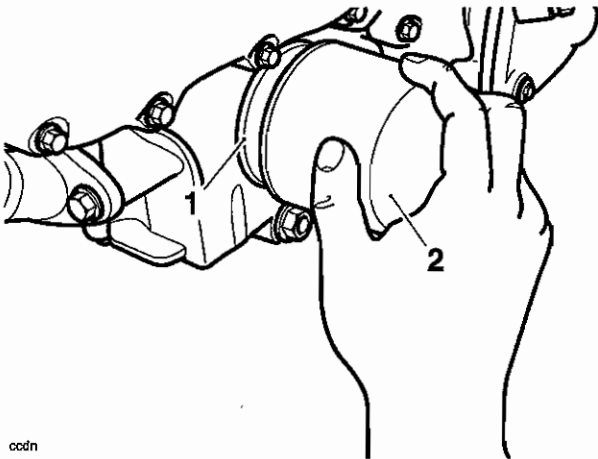

ccdn

- Oil filter
- Oil filter cover

- Position the oil drain pan beneath the oil filter.
- Unscrew and remove the oil filter using Triumph service tool T3880312. Dispose of the old filter in an environmentally friendly way.

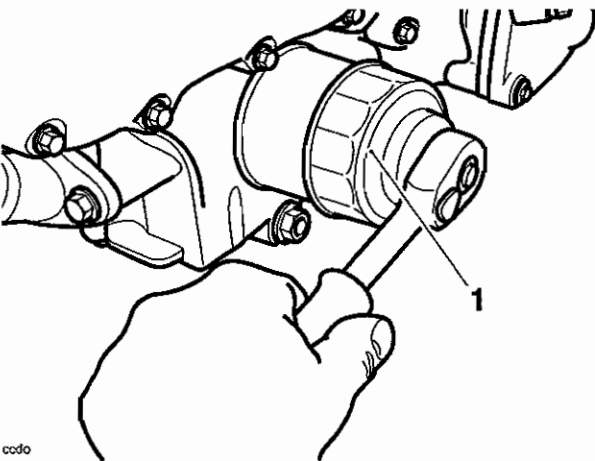

ccdo

- Tool T3880312

- Apply a thin smear of clean engine oil to the sealing ring of the new oil filter. Fit the oil filter and tighten to **10 Nm**.
- Fill the oil tank to the maximum mark with a 10W/40 or 15W/50 semi or fully synthetic motorcycle engine oil that meets specification API SH (or higher) AND JASO MA.
- Start the engine and allow it to idle for a minimum of 30 seconds.

! Caution

Raising the engine speed above idle before the oil reaches all parts of the engine can cause engine damage or seizure. Only raise engine speed after running the engine for a few seconds to allow the oil to circulate fully.

! Caution

If the engine oil pressure is too low, the low oil pressure warning light will illuminate. If this light stays on when the engine is running, stop the engine immediately and investigate the cause. Running the engine with low oil pressure will cause engine damage.

- Ensure that the low oil pressure warning light extinguishes shortly after starting.
- Turn off the ignition, check the oil level using the method previously described, and top-up to between the minimum and maximum marks.

Note:

- When the engine is first started after an oil and filter change, at least 1 to 1.5 litres of oil will be required to top-up the oil tank to the correct level.

Disposal of Used Engine Oil and Oil Filters

To protect the environment, do not pour oil on the ground, down sewers or drains, or into watercourses. Do not place used oil filters in with general waste. If in doubt contact your local authority.

Low Oil Pressure Warning Light Switch

Note:

- The low pressure warning light may be removed after first removing the rider's seat and disconnecting the battery leads, negative (black) lead first. The low oil pressure warning light switch is located at the rear of the cylinder head.

! Warning

Prolonged or repeated contact with engine oil can lead to skin dryness, irritation and dermatitis. Furthermore, used engine oil contains potentially harmful contaminants that can cause cancer. When handling used engine oil, always wear protective clothing and avoid any skin contact with the oil.

! Caution

Do not pour engine oil on the ground, down sewers or drains, or into watercourses. To prevent pollution of watercourses etc., dispose of used oil sensibly. If in doubt contact your local authority.

Removal

- Remove the rider's seat as described on page 17.9.
- Disconnect the battery, negative (black) lead first.
- Remove the right hand engine in-fill panel as described in the body section.
- Remove the fuel tank as described on page 11.99.
- Remove the intake duct as described on page 11.104.

- Withdraw the rubber boot from the low oil pressure warning light switch.

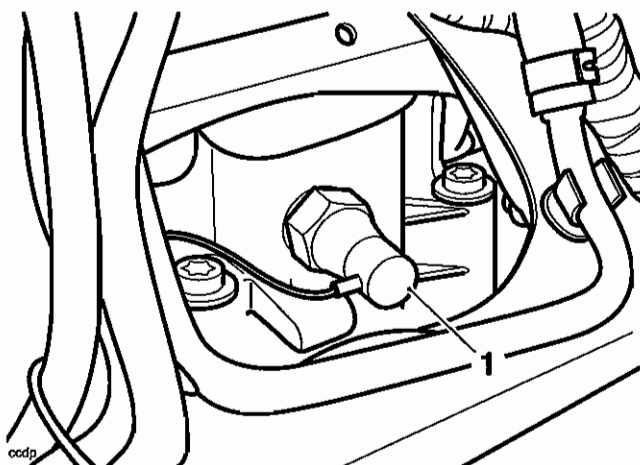

1. Oil pressure switch boot

- Unscrew the electrical connection.

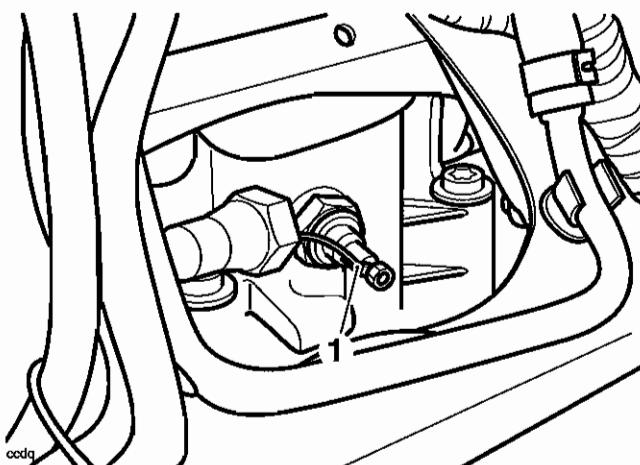

1. Oil pressure switch connection

Note:

- A small amount of oil will drain from the oil gallery when the switch is removed.
- Position a suitable receptacle to collect any displaced oil from the oil gallery.
 - Unscrew and remove the switch.

Lubrication

Installation

1. Incorporating a new sealing washer, fit the low oil pressure light switch, tightening it to **28 Nm**.

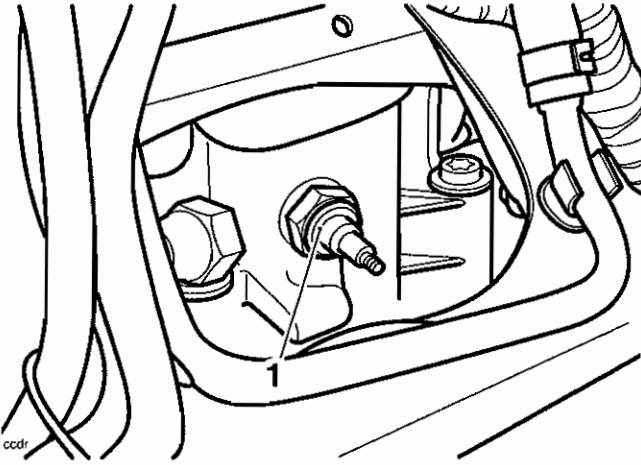

1. **Low oil pressure warning light switch**
2. Connect the wire to the switch and secure with the small screw.
3. Refit the boot.
4. Refit the intake duct as described on page 11.108.
5. Refit the fuel tank as described on page 11.99.
6. Fit the right hand engine infill panel as described on page 17.10.
7. Reconnect the battery, positive (red) lead first.
8. Fit the rider's seat.

Sump

Removal

1. Remove the rider's seat as described on page 17.9.
2. Disconnect the battery, negative (black) lead first.

Warning

Prolonged or repeated contact with engine oil can lead to skin dryness, irritation and dermatitis. Furthermore, used engine oil contains potentially harmful contaminants that can cause cancer. When handling used engine oil, always wear protective clothing and avoid any skin contact with the oil.

Caution

Do not pour engine oil on the ground, down sewers or drains, or into watercourses. To prevent pollution of watercourses etc., dispose of used oil sensibly. If in doubt contact your local authority.

3. Drain the engine oil as described on page 9.7.
4. Remove the sump bolts and lower the sump from the crankcase. Discard the sump gasket.

Inspection

Warning

Ensure the oil pick-ups are clean and free of blockages or restrictions. If the oil flow is restricted, oil pressure will be reduced and may cause severe engine damage.

Caution

If the oil pick-ups are removed, always use new pick-up bolts during reassembly. Use of the original bolts may lead to pick-up detachment leading to severe engine damage.

1. Check the oil pick-ups for blockages or restrictions. Remove and clean if found to be blocked or restricted.

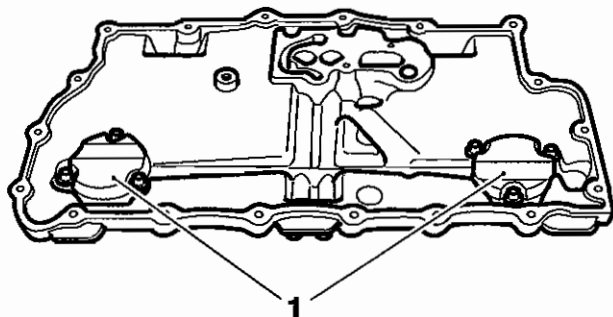

cods

1. Oil pick-ups

Installation

1. Position a new sump gasket to the sump and locate to the crankcase.
2. Fit the bolts to the sump and evenly and progressively tighten them to **12 Nm**.
3. Refill the oil tank as described on page 9.7.
4. Reconnect the battery, positive (red) lead first.
5. Refit the rider's seat.

Oil Pumps

Note:

- Two oil pumps are fitted to this model. A pressure pump to supply oil under pressure to various parts of the engine, and a twin-rotor scavenge pump to return oil to the oil tank from the sump.



Prolonged or repeated contact with engine oil can lead to skin dryness, irritation and dermatitis. Furthermore, used engine oil contains potentially harmful contaminants that can cause cancer. When handling used engine oil, always wear protective clothing and avoid any skin contact with the oil.



Do not pour engine oil on the ground, down sewers or drains, or into watercourses. To prevent pollution of watercourses etc., dispose of used oil sensibly. If in doubt contact your local authority.

Removal

Note:

- Only the pressure pump can be removed with the engine in frame. If removing the pressure pump, remove the clutch cover as described on page 4.7.

Note:

- To remove the scavenge pump, the engine must be removed and the crankcase halves must be separated. The following instructions describe the procedure for removal of both pumps simultaneously.
1. Remove the engine from the frame as described on page 10.2.
 2. Remove the clutch assembly as described on page 4.7.

Lubrication

3. Prevent the oil pump drive sprocket from turning using a hand-hold only. Remove the locknut from the drive sprocket shaft.

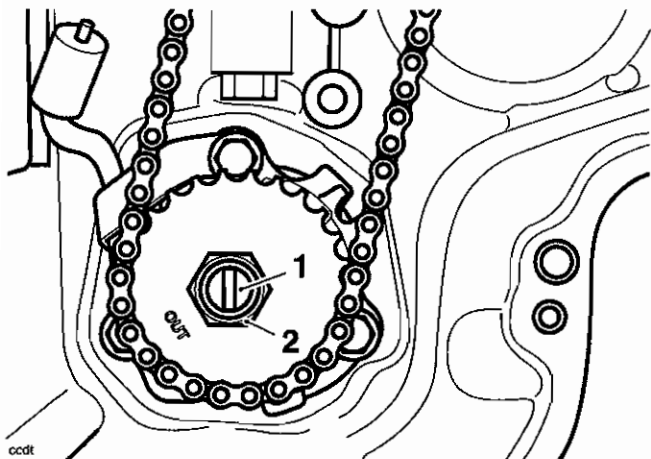

1. Drive sprocket shaft
2. Locknut

4. Remove the pump sprocket, drive sprocket and chain as one item by sliding them forward.
5. Note the position of the spray bar before releasing the bolts securing the pressure pump and spray bar to the crankcase. Withdraw the pressure pump and spray bar.

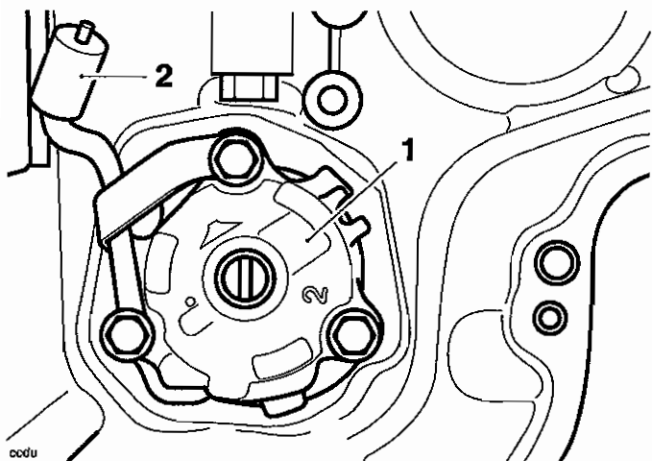

1. Pressure pump bolts
2. Spray bar

6. Recover the mesh filter situated between the pressure pump and crankcase.

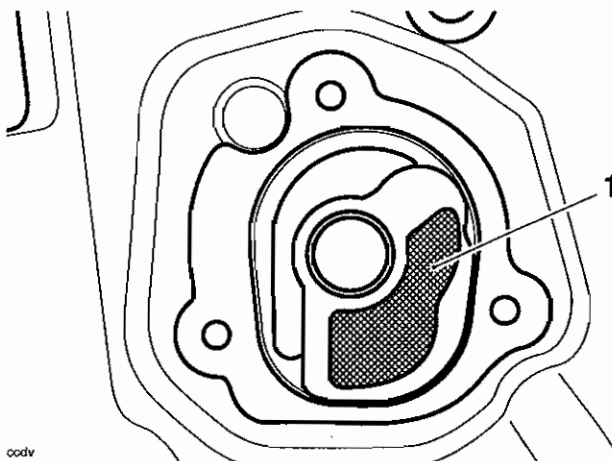

1. Mesh filter

7. Separate the crankcase halves as described on page 5.5.
8. Release the screws that secure the scavenge pump to the lower crankcase.

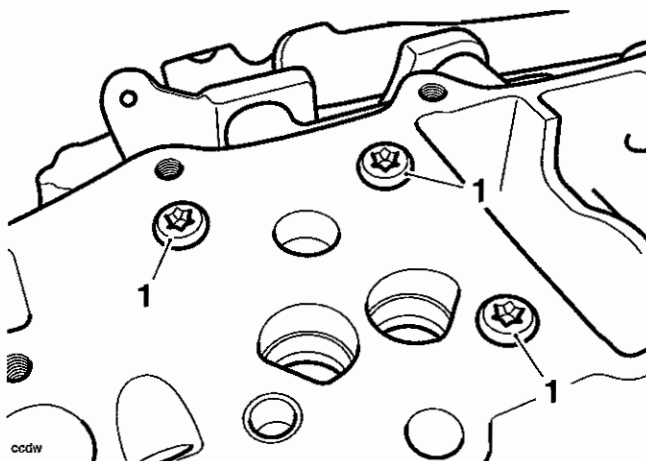

1. Scavenge pump screws

- Ease the pump from its dowels and withdraw it from the crankcase.

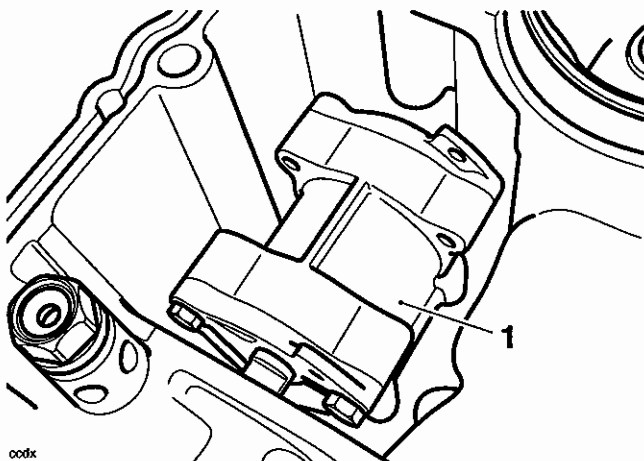

1. Scavenge pump

Inspection

⚠ Caution

If any part of either of the oil pumps is found to be outside the service limit, the complete pump must be replaced. Severe engine damage may result from the continued use of a faulty oil pump.

Clearances

| Item (both pumps) | Standard | Service limit |
|------------------------------|----------------|---------------|
| Oil pump rotor tip clearance | 0.15 mm | 0.30 mm |
| Oil pump body clearance | 0.15 – 0.22 mm | 0.35 mm |
| Oil pump rotor end float | 0.02 – 0.07 mm | 0.10 mm |

- Measure the rotor tip clearance using feeler gauges.

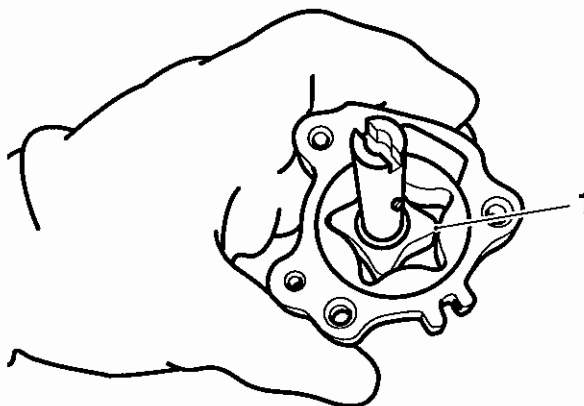

1. Rotor tip clearance

- Measure the pump body clearance using feeler gauges.

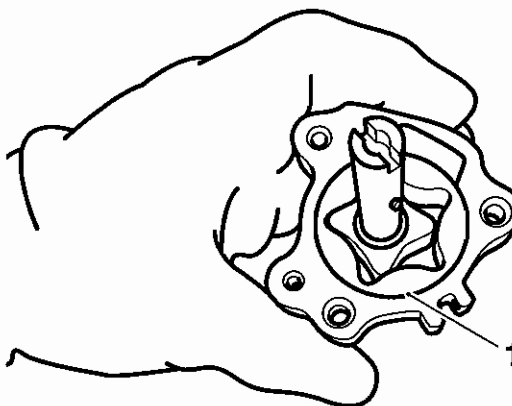

1. Pump body clearance

- Measure the pump end clearance.
- Clearances:
 - If all clearances are within service limits, liberally apply clean engine oil to all internal components and refit the oil pump plate to the oil pump body.
 - If any clearance measured is outside the service limits, renew the complete pump.
- Inspect all the sprocket and chain for wear and/or damage. Replace the sprocket and chain if wear and/or damage is found.

Lubrication

Installation

⚠ Caution

As a precaution, before fitting the oil pumps to the crankcase ensure the pump internal surfaces have been 'wetted' with clean engine oil. The pumps may fail to pick-up oil from the sump if the surfaces have not been 'wetted'. This will cause the engine to run without engine oil pressure and will lead to severe engine damage.

1. Fill the oil pumps with new engine oil, turning the pump rotors as the oil is poured into the pump.
2. Position the scavenge pump to the crankcase and engage it to the mounting dowels. Ensure the drive blade is facing towards the front of the engine.

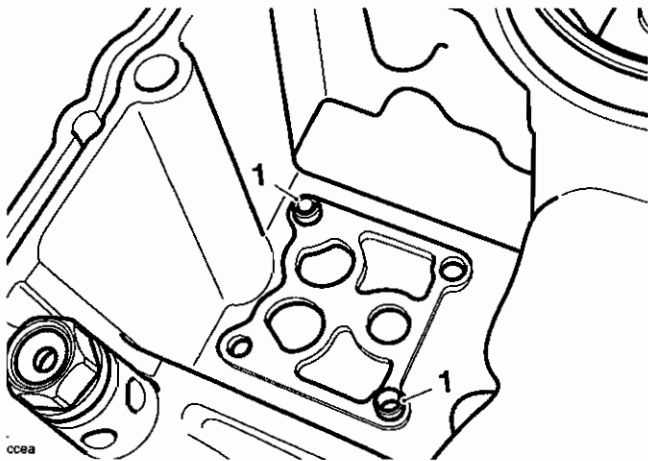

1. Mounting dowels

3. Fit and tighten the scavenge pump screws to **12 Nm**.

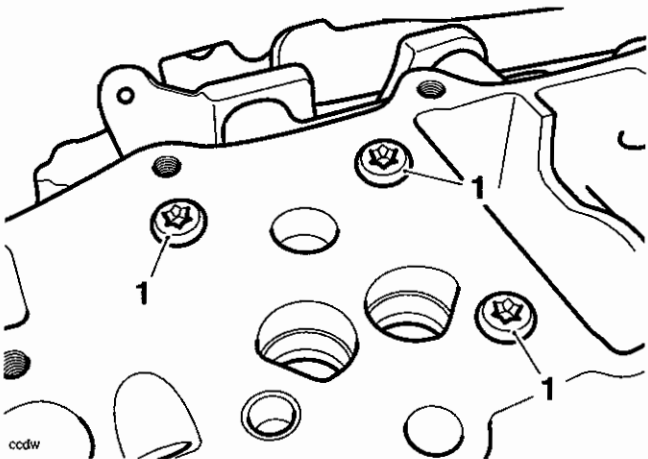

1. Scavenge pump screws

4. Position the pressure pump and spray bar to the crankcase, aligning the drive blade on the scavenge pump with the drive slot on the pressure pump.

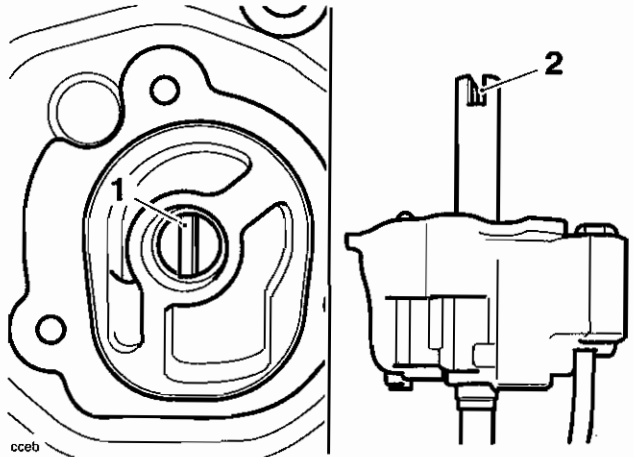

1. Scavenge pump – drive blade

2. Pressure pump – drive slot

5. Clean and examine the mesh filter for the pressure pump before refitting it to the crankcase. Replace the filter if blocked, split or damaged in any way.

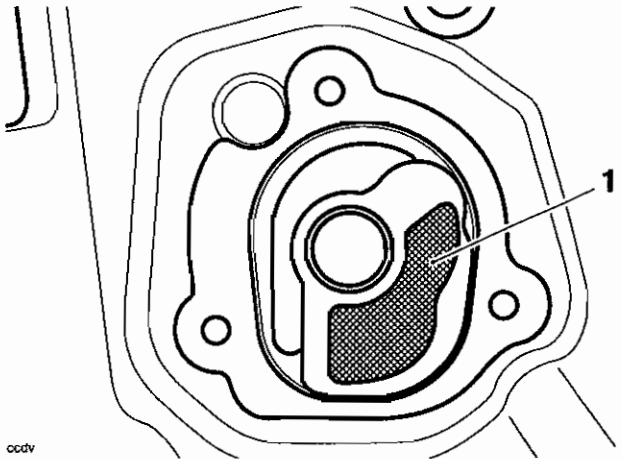

1. Mesh filter

6. Fit and tighten the pressure pump and spray bar screws to **12 Nm**.
7. Assemble the crankcase halves as described on page 5.7.

- Assemble the pump sprocket and drive socket to the chain ensuring the "OUT" mark on the pump socket is facing outwards.

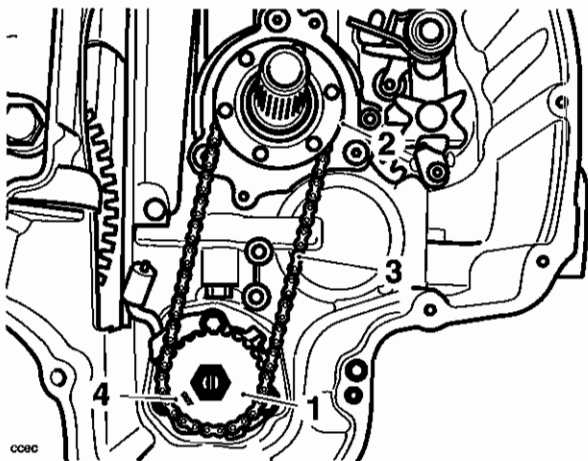

- Pump sprocket
- Drive sprocket
- Chain
- "OUT" mark

- Secure the pump sprocket to the pump shaft with a new locknut. Tighten the nut to **30 Nm**.
- Assemble the crankcase halves as described on page 5.7.
- Install the engine in the frame as described on page 10.5.

Oil Non-Return Valve

The oil non-return valve, which prevents oil from draining from the oil tank while the engine is not running, is located in the upper crankcase. It can be removed by easing it gently from the crankcase against the O-ring that seals it.

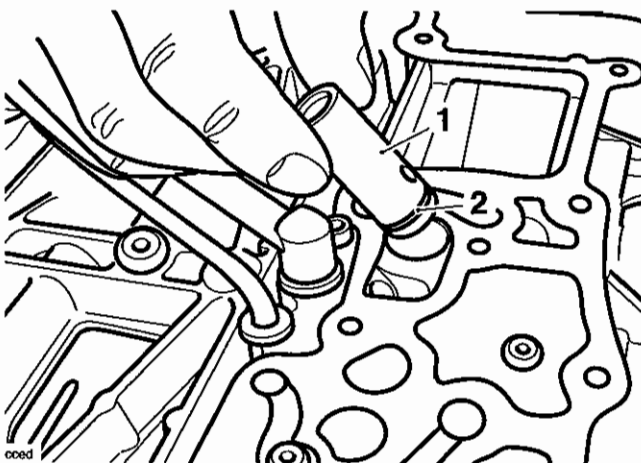

- Oil non-return valve
- O-ring

Oil Pressure Relief Valve

The oil pressure relief valve is located in the lower crankcase, adjacent to the scavenge pump. It is a threaded fit in the crankcase.

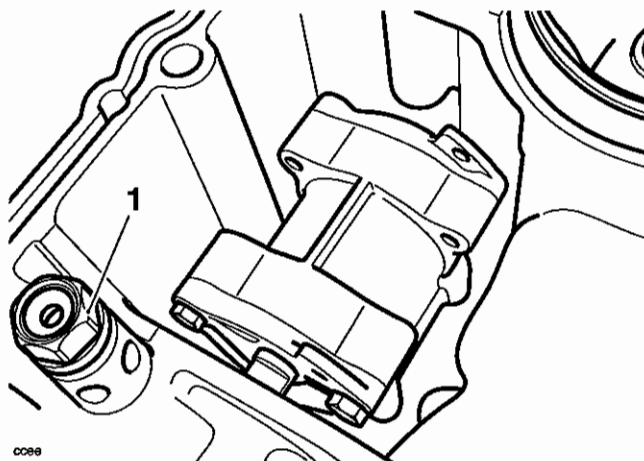

- Oil pressure relief valve

When refitting the valve, tighten it to **15 Nm**.

Lubrication

Oil Tank

Removal

1. Remove the throttle bodies as described on page 11.121.
2. Drain the oil tank as described on page 9.7.
3. Release the spring clip securing the breather hose to the tank. Detach the hose and remove the tank.

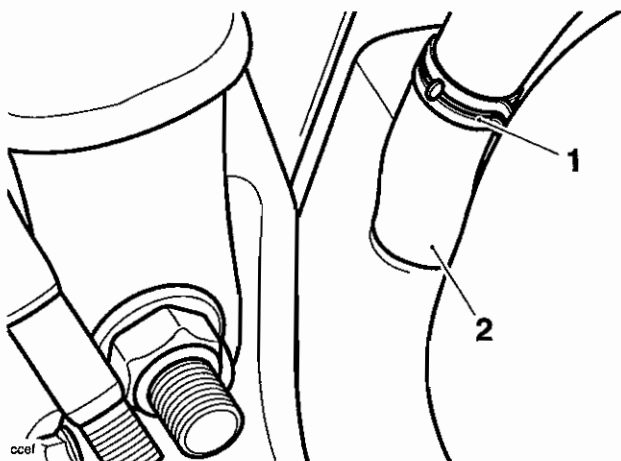

1. Hose clip

2. Hose

4. Release the three bolts securing the oil tank to the upper crankcase.
5. Ease the oil tank upwards to detach it from the gallery in the crankcase.
6. Remove the link tube from the crankcase by pulling gently upwards.

Inspection

1. Check the tank for damage, deformation and splits. Replace the tank as necessary.
2. Check the breather hose for damage, splits and signs of collapse. Replace the hose as necessary.
3. Thoroughly clean the tank inside and out. Ensure no debris remains inside the tank.

Installation

1. Fit a new O-rings to the oil tank outlet and both ends of the link tube. Lubricate the O-rings with engine oil or petroleum jelly.
2. Refit the link tube to the upper crankcase.
3. Position the tank to the upper crankcase and link tube.
4. Locate the oil tank outlet to the link tube ensuring the O-ring is not damaged or dislodged during fitment.
5. Fit and tighten the oil tank screws; to **28 Nm** (vertical fixings) and **12 Nm** (horizontal fixing).
6. Attach the breather hose and attach the spring clip.
7. Refit the throttle bodies as described on page 11.122.
8. Refill the tank and engine with oil as described on page 9.16.

Oil Transfer Pipes

Oil transfer pipes are fitted to the lower crankcase to transfer oil to the transmission.

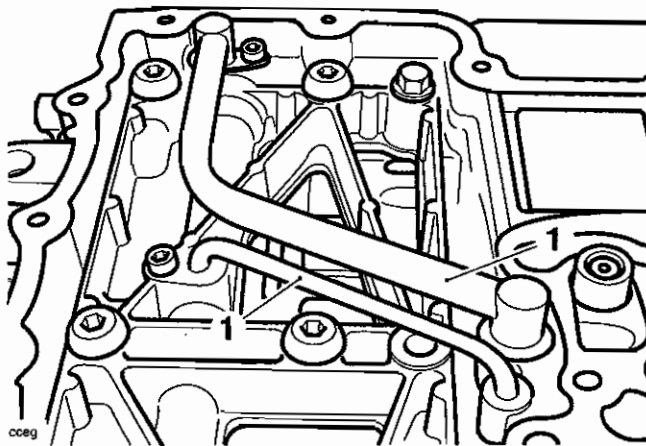

1. Oil transfer pipes

Each pipe is retained by a screw at one end and is sealed at both ends by O-rings. If the pipes are removed, always renew the O-rings and tighten the screws to **9 Nm**.

10 Engine Removal and Refit

Table of Contents

| | |
|--------------------|------|
| Removal | 10.2 |
| Installation | 10.5 |

Engine Removal and Refit

Removal

Warning

Before starting work, ensure the motorcycle is stabilised and adequately supported. This will help prevent it from falling and causing injury to the operator or damage to the motorcycle.

To gain access to the engine for removal:

1. Raise and securely support the motorcycle and engine.
2. Remove the rider's seat.
3. Disconnect the battery, negative (black) lead first, then remove it as described on page 18.9.
4. Remove the left and right side panels as described on page 17.9.
5. Drain the engine oil as described on page 9.7.
6. Remove the fuel tank as described on page 11.99.
7. Disconnect the throttle cables as described on page 11.116.
8. Remove the exhaust header system as described on page 11.133.

Note:

- **The catalyst box and silencers can remain in place.**
9. Remove the radiator as described on page 12.11.
 10. Remove the throttle bodies and intake hose as described on page 11.121.
 11. Remove the oil tank as described on page 9.16.
 12. Remove the rear wheel as described on page 16.8.
 13. Remove the swinging arm, bevel box and rear suspension units as described in section 6.
 14. Remove the front wheel as described on page 16.6.
 15. Remove the front mudguard as described on page 17.10.

16. Remove the rear brake master cylinder heel guard.

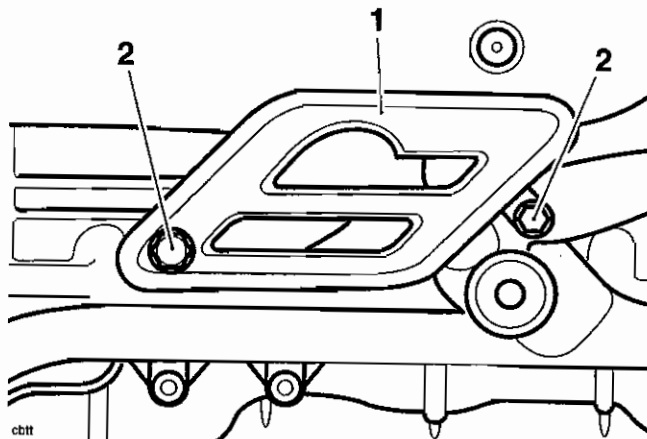

1. Heel guard
2. Heel guard fixings

17. Remove the clip from the rear brake pedal clevis pin. Remove the clevis pin.

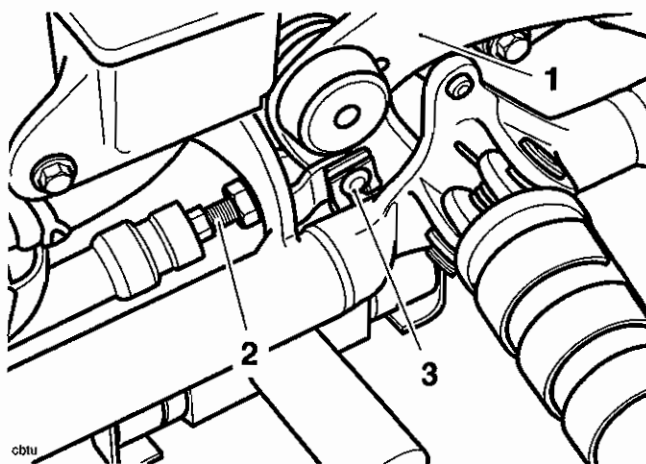

1. Pedal
2. Pushrod
3. Clevis

18. Temporarily support the rear brake master cylinder then remove the bolts securing it to the footrest mounting bar.

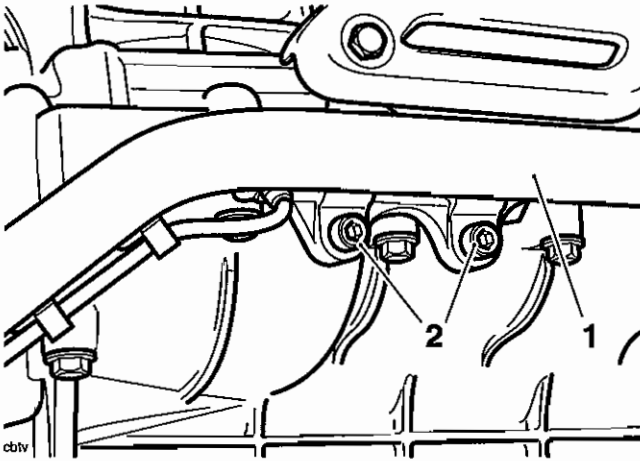

1. Footrest mounting bar
2. Master cylinder bolts

Note:

- It is not necessary to disconnect the brake pipe from the master cylinder.

19. Unclip the brake pipe.

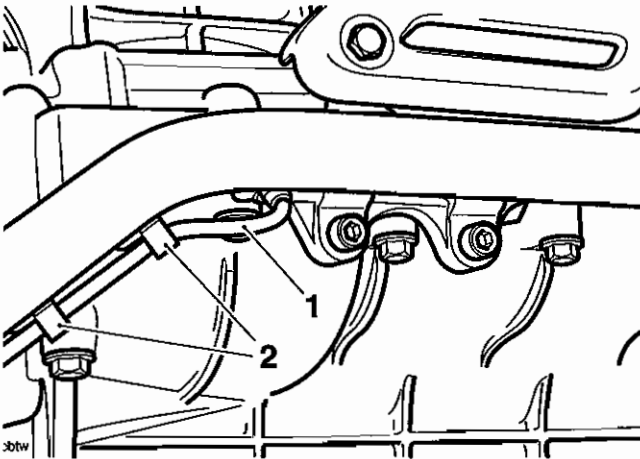

1. Brake Pipe
2. Clips

20. Remove the heat shield from the brake pipe joint.

21. Release the fixing securing the brake pipe joint to the frame outrigger.

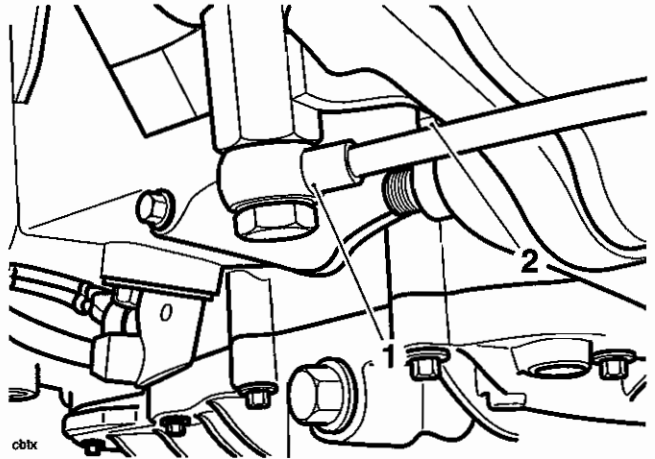

1. Brake pipe joint
2. Bolt

22. Detach the five bolts securing the footrest mounting bar to the frame and crankcase. Detach the bar.

⚠ Caution

When repositioning the rear brake master cylinder, take care to prevent the steel brake pipe from becoming distorted.

23. Position the master cylinder, brake pipe and joint in a safe place, preventing the brake fluid reservoir from becoming inverted.

24. Select neutral and note the position of the gear change crank relative to the selector shaft.

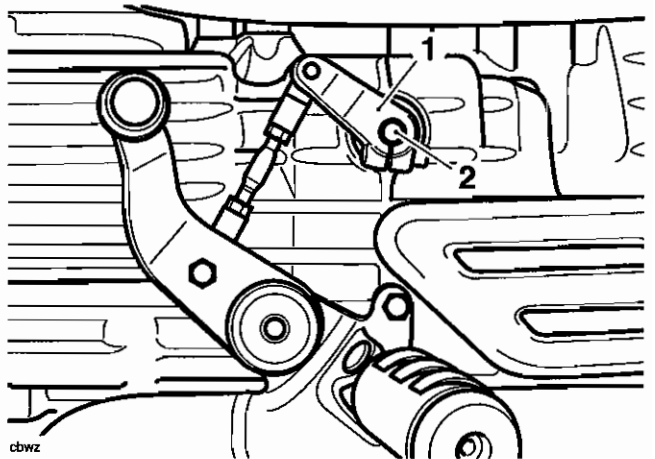

1. Gear change crank
2. Selector shaft

25. Remove the bolt from the gear change crank. Detach the crank.

Engine Removal and Refit

26. Release the bolts securing the left hand footrest mounting bar to the frame and engine. Detach the bar.
27. Noting their respective positions, disconnect the spark plug leads from the spark plugs.
28. Disconnect the side stand switch.
29. Remove the side stand complete with its mounting bracket.

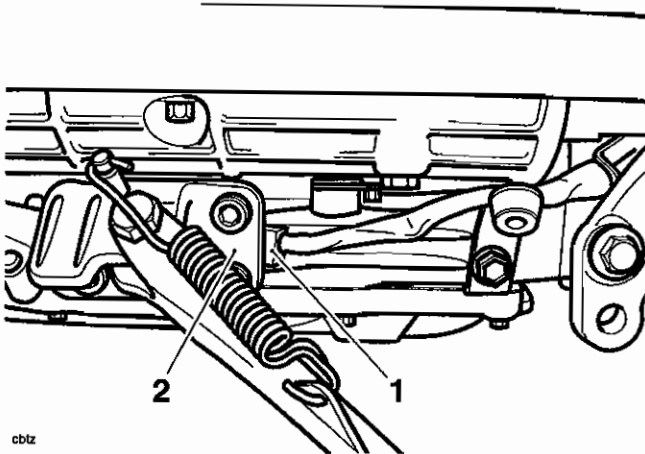

cbtz

1. Side stand switch connections
2. Side stand bracket

30. Release the clip securing the engine breather hose to the engine. Detach the hose.
31. Disconnect all electrical connections to the engine. These include:
 - Low oil pressure warning light switch
 - Crankshaft position sensor
 - Gear position sensor
 - Road speed sensor
 - Coolant temperature sensor
 - Battery earth
 - Starter motor connections
32. Undo the bolts securing the airbox to the frame.
33. Detach the breather hose at the crankcase.

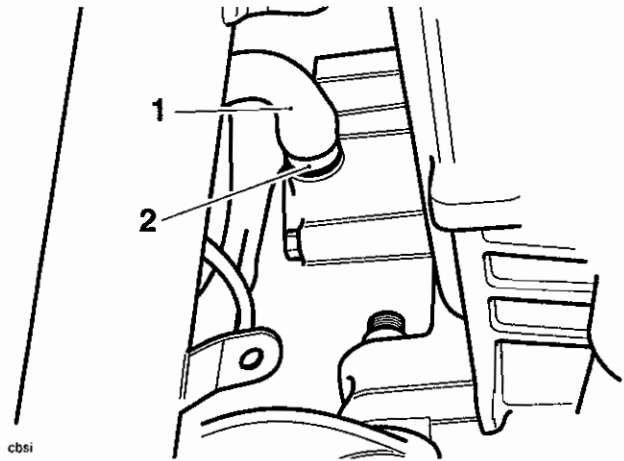

cbxi

1. Breather hose
2. Clip

Note:

- It is not necessary to remove the airbox, but allowing it to float within the frame is helpful.

34. Check that the engine is still securely supported.
35. Undo all engine mounting bolts and nuts, leaving the bolts in place until later.
36. Release the engine mounting adjuster collar and adjusters on the right side of the frame using service tool T3880063.

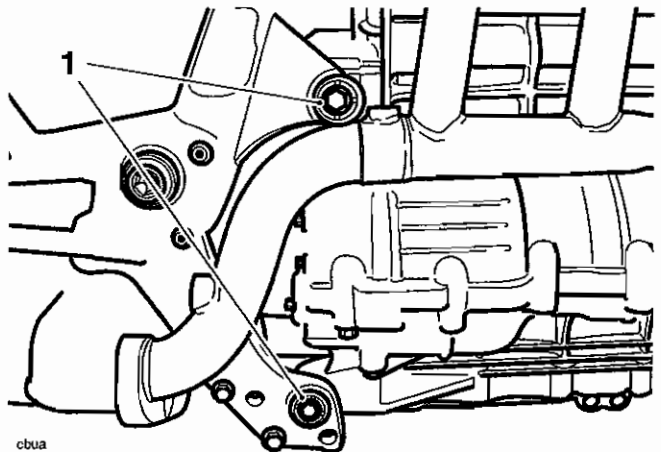

cbua

1. Adjuster collars

37. Have several colleagues support the frame, then remove all engine mounting bolts from the engine mountings.
38. Leaving the engine on its support, lift the frame off the engine.

Installation

Note:

- **As the frame is being lowered onto the engine, reconnect the low oil pressure warning light switch and attach the breather hose.**

1. Locate the frame to the engine aligning the engine mounting points with the corresponding positions on the frame.
2. Install the engine mounting bolts and nuts, but do not tighten any yet.

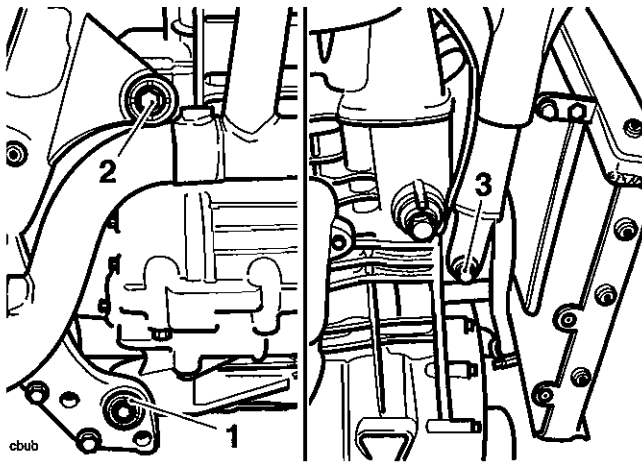

1. Lower rear mounting bolt (one per side)
2. Upper rear mounting bolt (one per side)
3. Front mounting bolt

3. Tighten the engine mounting bolts, nuts, adjusters and adjuster collars in the following sequence:

- Tighten the upper and lower left hand rear engine mounting bolts and nuts to **80 Nm**.
- Support the frame and engine, and temporarily remove the rear right hand mounting bolts.
- Tighten the right hand rear adjusters to **5 Nm**.
- Refit the rear right hand mounting bolts.
- Tighten the upper and lower rear right hand engine mountings to **80 Nm**.
- Using service tool T3880063, tighten the locking collars on both right hand engine mounting adjusters to **55 Nm**.
- Tighten the front engine mounting bolt and nut to **80 Nm**.

4. Reconnect the remaining electrical connections to the engine. These include:
 - Low oil pressure warning light switch
 - Crankshaft position sensor
 - Gear position sensor
 - Road speed sensor
 - Coolant temperature sensor
 - Battery earth
 - Starter motor connections
5. Attach and secure the engine breather hose with its clip.
6. Position the airbox to its mountings, fit and tighten its bolts to **9 Nm**.
7. Refit the side stand, tightening the fixings to **40 Nm**.
8. Reconnect the side stand switch.
9. Reconnect the spark plug leads.
10. Position the left hand footrest mounting bar to the frame and engine.
11. Fit and tighten the bar's mounting bolts to **27 Nm**.

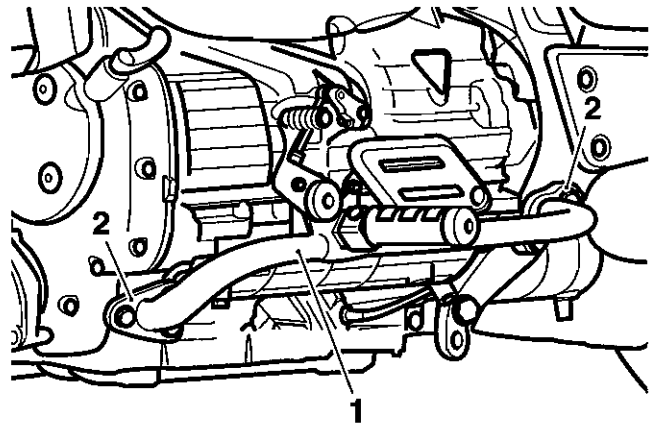

1. Left hand footrest mounting bar
2. Fixings

Engine Removal and Refit

12. Position the gear change crank to the selector shaft engaging the splines as noted during removal.

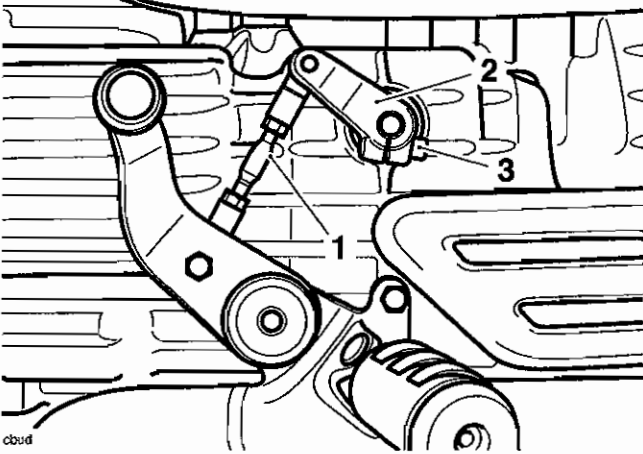

1. Selector rod
2. Gear change crank
3. Pinch bolt

13. Fit the pinch bolt to the crank and tighten it to **9 Nm**.
14. Support the rear brake master cylinder assembly while aligning the brake pipe joint to the frame outrigger. Tighten the bolt retaining the brake pipe joint to **20 Nm**.

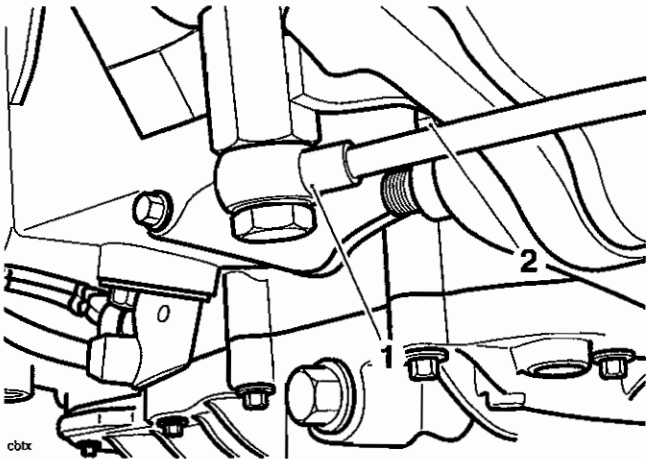

1. Brake pipe joint
2. Fixing

15. Position the right hand footrest mounting bar to the frame and engine.

16. Fit and tighten the bar's mounting bolts to **27 Nm**.

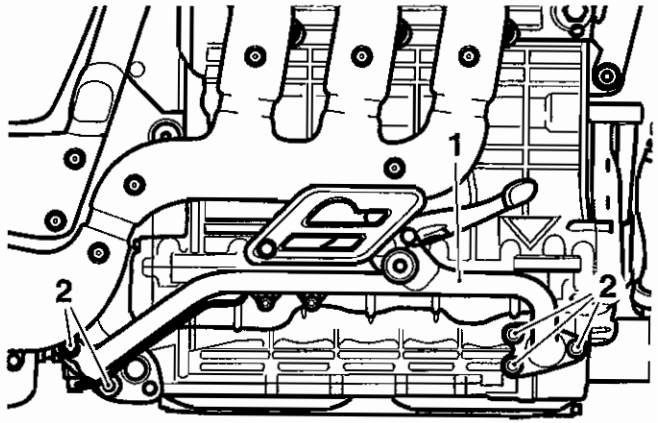

1. Right hand footrest mounting bar
2. Fixings

17. Position the master cylinder to the right hand footrest mounting bar. Fit and tighten the master cylinder bolts to **27 Nm**.
18. Align the brake pedal with the pushrod, engage the clevis and retain it with the clip. Ensure the clip is fitted as shown below.

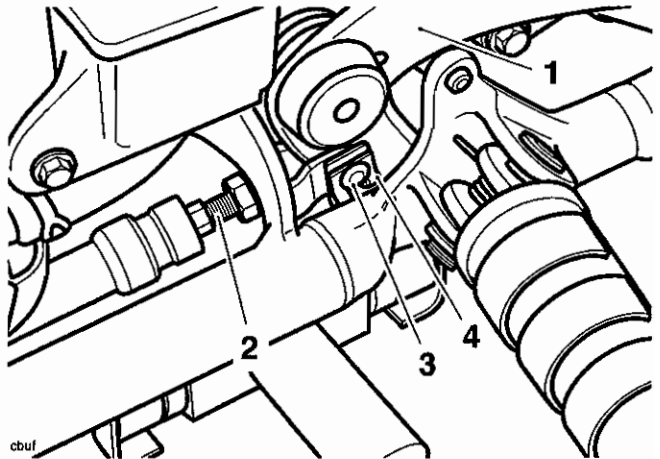

1. Pedal
2. Pushrod
3. Clevis
4. Clip

19. Refit the heel guard tightening the fixings to **9 Nm**.

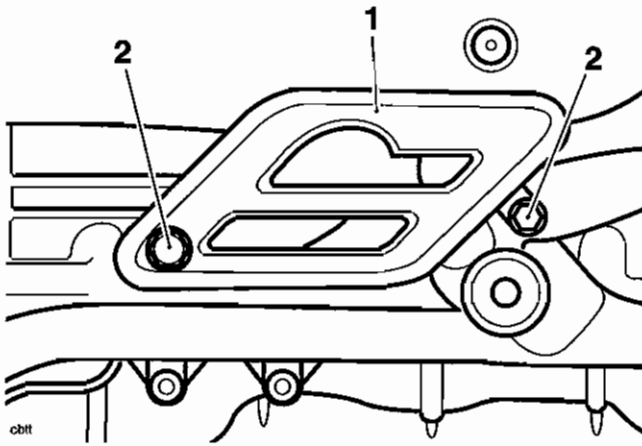

- 1. Heel guard
- 2. Heel guard fixings

20. Fit the brake pipe to its clip.

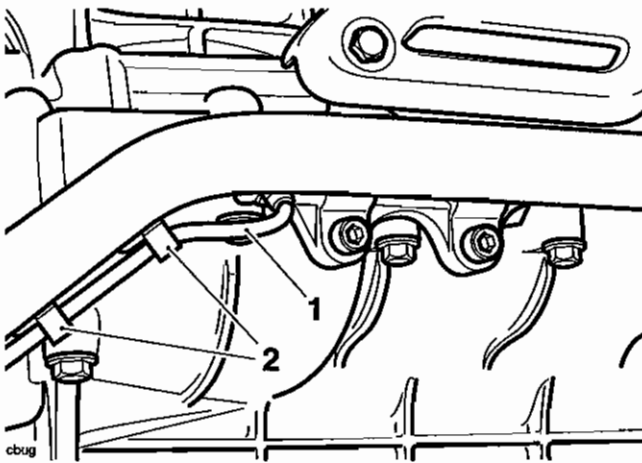

- 1. Brake pipe
- 2. Clip

21. Refit the front mudguard as described on page 17.11.
22. Refit the front wheel as described on page 16.7.
23. Refit the swinging arm, bevel box and rear suspension units as described in section 6.
24. Refit the rear wheel as described on page 16.9.
25. Refit the oil tank as described on page 9.16.
26. Refit the throttle bodies and intake hose as described on page 11.122.
27. Reconnect and adjust the throttle cables as described on page 11.117 and 11.118.
28. Refit the radiator as described on page 12.13.
29. Refit the exhaust headers as described on page 11.135.
30. Refit the fuel tank as described on page 11.100.
31. Refill the engine with oil as described on page 9.8.
32. Reconnect the battery, positive (red) lead first.
33. Refit the rider's seat.
34. Lower the motorcycle to the ground and place it on the side stand.
35. Start the engine and check for oil, coolant and any other leaks.
36. Check and adjust the engine oil level.

This page intentionally left blank

11 Fuel System/Engine Management

| | |
|---|-------|
| Exploded View - Fuel Tank..... | 11.7 |
| Exploded View - Fuel Pump..... | 11.8 |
| Exploded View - Fuel Rail, Throttles and Injectors..... | 11.9 |
| Exploded View - Airbox..... | 11.10 |
| Exploded View - Exhaust System..... | 11.11 |
| Exploded View - Evaporative System..... | 11.12 |
| Fuel Requirements..... | 11.13 |
| Fuel Requirements - all countries except USA..... | 11.13 |
| Fuel Requirements - USA..... | 11.13 |
| Oxygenated Gasoline..... | 11.13 |
| Ethanol..... | 11.13 |
| Methanol..... | 11.13 |
| MTBE (Methyl Tertiary Butyl Ether)..... | 11.13 |
| Glossary of Terms..... | 11.14 |
| Air temperature..... | 11.14 |
| Air temperature sensor..... | 11.14 |
| ATDC..... | 11.14 |
| Barometric pressure..... | 11.14 |
| Battery voltage..... | 11.14 |
| BTDC..... | 11.14 |
| Catalyst..... | 11.14 |
| Closed throttle position..... | 11.14 |
| Coolant temperature..... | 11.14 |
| Coolant temperature sensor..... | 11.14 |
| Cooling fan status..... | 11.14 |
| DTC..... | 11.14 |
| ECM..... | 11.14 |
| Engine speed..... | 11.14 |
| Freeze frame..... | 11.14 |
| Idle fuel trim..... | 11.14 |
| Idle fueling..... | 11.14 |
| Idle reference speed..... | 11.14 |
| Ignition advance..... | 11.14 |
| Ignition switch position..... | 11.14 |

Fuel System/Engine Management

| | |
|---|-------|
| Ignition timing | 11.14 |
| Injector pulse time | 11.14 |
| Long term fuel trim | 11.14 |
| MAP sensor | 11.15 |
| MIL | 11.15 |
| Neutral switch status | 11.15 |
| Off idle fuel trim | 11.15 |
| Open circuit | 11.15 |
| Over temp | 11.15 |
| Primary Throttle Position Sensor | 11.15 |
| Primary Throttle Stepper Motor | 11.15 |
| Purge valve duty cycle | 11.15 |
| Road Speed Sensor | 11.15 |
| Second Throttle Position Sensor | 11.15 |
| Second Throttle Stepper Motor | 11.15 |
| Sensor reference voltage | 11.15 |
| Short circuit | 11.15 |
| Short term fuel trim | 11.15 |
| Sidestand status | 11.15 |
| Target dwell time | 11.15 |
| Throttle position | 11.15 |
| Throttle voltage | 11.15 |
| Vbatt | 11.15 |
| Engine Management System | 11.16 |
| System Description | 11.16 |
| System Sensors | 11.16 |
| Sensor Locations | 11.17 |
| System Actuators | 11.18 |
| Actuator Locations | 11.19 |
| Engine Management Circuit Diagram - Rocket III | 11.20 |
| Circuit Diagram - Engine Management System - Rocket III | 11.21 |
| System Diagnostics | 11.22 |
| On-board Fault Detection System | 11.22 |
| Triumph Diagnostic Tool | 11.22 |
| Current Data | 11.23 |
| Freeze-frame Data | 11.23 |
| Function Tests | 11.24 |
| Checks/Adjustments | 11.24 |
| Adjustments | 11.24 |
| Adaption status | 11.24 |
| Build data | 11.24 |
| Checks | 11.25 |
| Diagnostic Trouble Codes | 11.26 |
| Service Diagnostic Tool | 11.28 |
| Typical screen showing symbol examples | 11.28 |

Fuel System/Engine Management

| | |
|---------------------------------------|-------|
| Tool Keys | 11.28 |
| Electrical Connectors | 11.58 |
| Before Disconnection:..... | 11.58 |
| When Disconnecting a Connector:..... | 11.58 |
| When Inspecting a Connector:..... | 11.58 |
| When Connecting a Connector..... | 11.58 |
| Disconnection of ECM connectors | 11.58 |
| Reconnection of ECM connectors | 11.59 |
| Further Diagnosis | 11.59 |
| Crankshaft Sensor | 11.60 |
| Pinpoint Tests | 11.60 |
| Idle Speed Control | 11.62 |
| Pinpoint Tests | 11.62 |
| Fuel Injectors | 11.64 |
| Pinpoint Tests | 11.64 |
| Throttle Position Sensor | 11.66 |
| Pinpoint Tests | 11.66 |
| Purge Valve | 11.68 |
| Pinpoint Tests | 11.68 |
| Ignition Coils | 11.70 |
| Pinpoint Tests | 11.70 |
| Coolant Temperature Sensor | 11.72 |
| Pinpoint Tests | 11.72 |
| Inlet Air Temperature Sensor | 11.74 |
| Pinpoint Tests | 11.74 |
| Fuel Pump Relay | 11.76 |
| Pinpoint Tests | 11.76 |
| System Voltage..... | 11.77 |
| Pinpoint Tests | 11.77 |
| Cooling Fan Relay | 11.78 |
| Pinpoint Tests | 11.78 |
| Tachometer..... | 11.79 |
| Pinpoint Tests | 11.79 |
| Coolant Temperature Indication | 11.80 |
| Pinpoint Tests | 11.80 |
| Vehicle Speed Output..... | 11.81 |
| Pinpoint Tests | 11.81 |
| Lambda Sensor..... | 11.82 |
| Pinpoint Tests | 11.82 |
| Lambda Sensor Heater..... | 11.83 |

Fuel System/Engine Management

| | |
|--|--------|
| Pinpoint Tests | 11.83 |
| EEPROM Error | 11.84 |
| Fall Detection Switch | 11.85 |
| Pinpoint Tests | 11.85 |
| 2nd Throttle Position Sensor | 11.86 |
| Pinpoint Tests | 11.86 |
| 2nd Throttle Actuator | 11.88 |
| Pinpoint Tests | 11.88 |
| Vehicle Speed Sensor | 11.90 |
| Pinpoint Tests | 11.90 |
| Ambient Pressure Sensor | 11.91 |
| Pinpoint Tests | 11.91 |
| Manifold Absolute Pressure (Map) Sensor | 11.92 |
| Pinpoint Tests | 11.92 |
| Gear Position Sensor | 11.93 |
| Pinpoint Tests | 11.93 |
| Fuel Level Sensor Circuit | 11.94 |
| Pinpoint Tests | 11.94 |
| Fuel Level Warning Light Circuit | 11.95 |
| Pinpoint Tests | 11.95 |
| Fuel Level Gauge | 11.96 |
| Pinpoint Tests | 11.96 |
| Fault Finding - Non Electrical | 11.97 |
| Fuel Tank | 11.98 |
| Fuel tank - raising | 11.98 |
| Fuel tank - lowering and securing | 11.99 |
| Fuel tank – removal | 11.100 |
| Fuel tank - refit | 11.101 |
| Fuel Pump, Filter and Pressure Regulator | 11.101 |
| Removal | 11.101 |
| Inspection | 11.103 |
| Assembly | 11.103 |
| Installation | 11.104 |
| Airbox, Intake Duct and Hoses | 11.105 |
| Removal | 11.105 |
| Electrical connections | 11.106 |
| Installation | 11.109 |
| Air Filter | 11.111 |
| Removal | 11.111 |
| Assembly | 11.112 |

Fuel System/Engine Management

| | |
|---|--------|
| Intake Air Temperature Sensor | 11.112 |
| Removal | 11.112 |
| Installation | 11.112 |
| Manifold Absolute Pressure (Map) Sensor | 11.113 |
| Removal | 11.113 |
| Installation | 11.113 |
| Barometric Pressure Sensor | 11.113 |
| Removal | 11.113 |
| Installation | 11.113 |
| Gear Position Sensor | 11.114 |
| Removal | 11.114 |
| Installation | 11.114 |
| Road Speed Sensor | 11.115 |
| Removal | 11.115 |
| Installation | 11.115 |
| Crankshaft Position Sensor | 11.116 |
| Removal | 11.116 |
| Installation | 11.116 |
| Throttle Cables | 11.117 |
| Removal | 11.117 |
| Examination | 11.118 |
| Installation | 11.118 |
| Throttle cable adjustment | 11.119 |
| Throttle Body Balancing | 11.121 |
| Balance throttles screen | 11.121 |
| Throttle Body | 11.122 |
| Removal | 11.122 |
| Installation | 11.123 |
| Injectors and Fuel Rail | 11.125 |
| Removal | 11.125 |
| Assembly/installation | 11.126 |
| Primary Throttle Potentiometer | 11.126 |
| Removal | 11.126 |
| Installation | 11.127 |
| Secondary Throttle Potentiometer | 11.128 |
| Removal | 11.128 |
| Installation | 11.128 |
| Idle Speed Control Stepper Motor | 11.130 |
| Removal | 11.130 |
| Installation | 11.130 |
| Engine Management Adaption | 11.133 |
| General Information | 11.133 |

Fuel System/Engine Management

| | |
|--|--------|
| Adaption Status | 11.133 |
| Terminology | 11.133 |
| Typical Values | 11.133 |
| Fault Indications | 11.134 |
| Exhaust System | 11.134 |
| Removal | 11.134 |
| Installation | 11.136 |
| Evaporative Loss Control System - California Models Only | 11.138 |
| California Models Only | 11.138 |
| Component Locations (all situated behind the left hand side cover) | 11.138 |
| Evaporative Control System - Engine Off | 11.139 |
| Evaporative Control System - Engine Running | 11.140 |

Fuel System/Engine Management

Exploded View - Fuel Tank

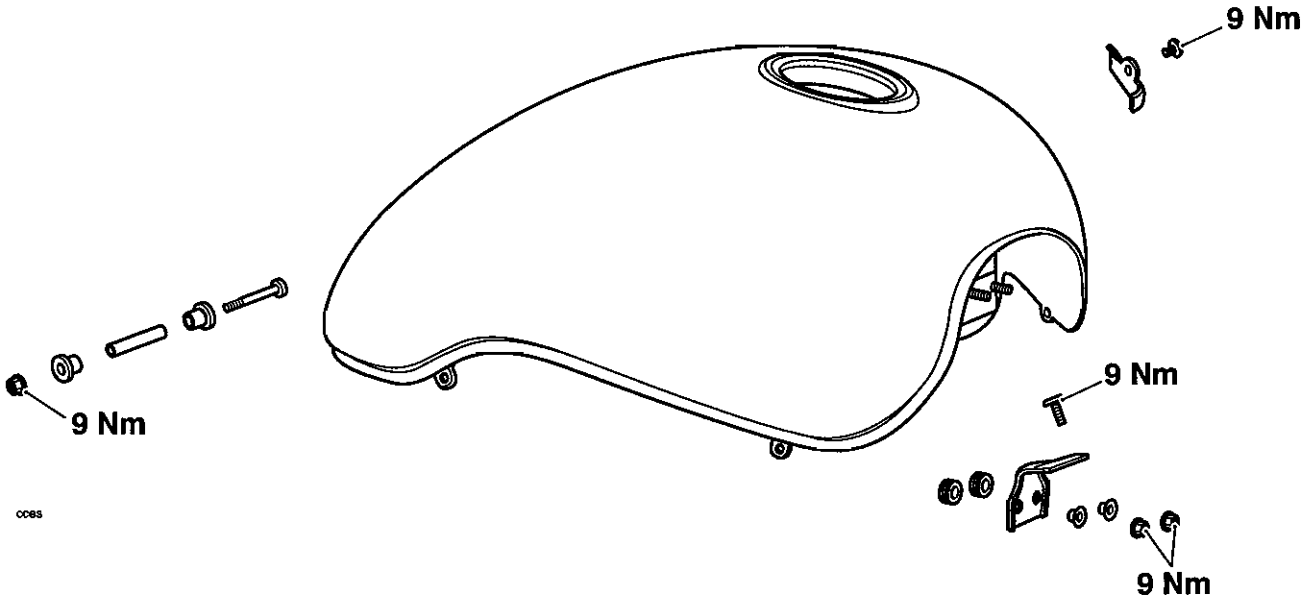

Exploded View - Fuel Pump

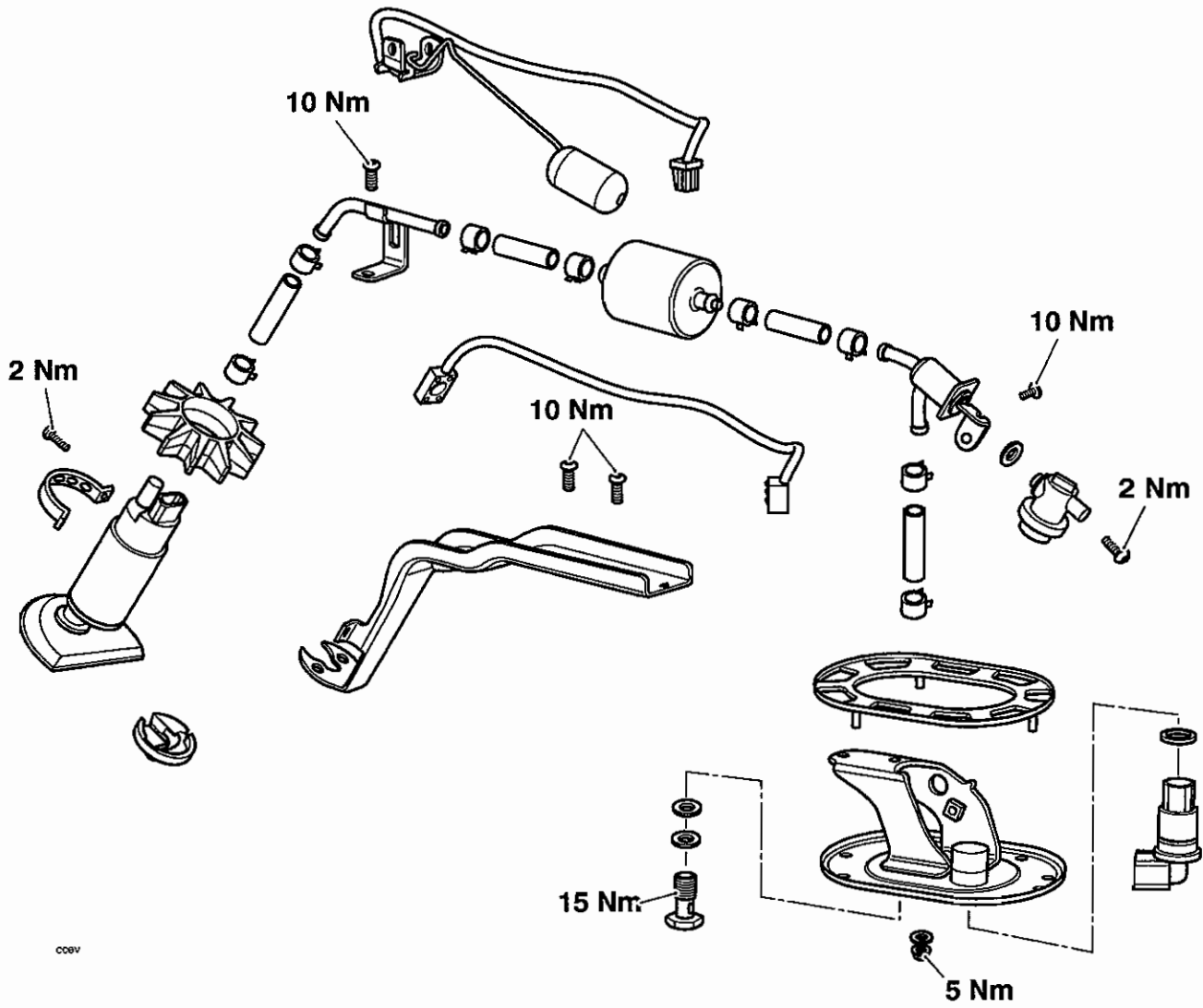

Fuel System/Engine Management

Exploded View - Fuel Rail, Throttles and Injectors

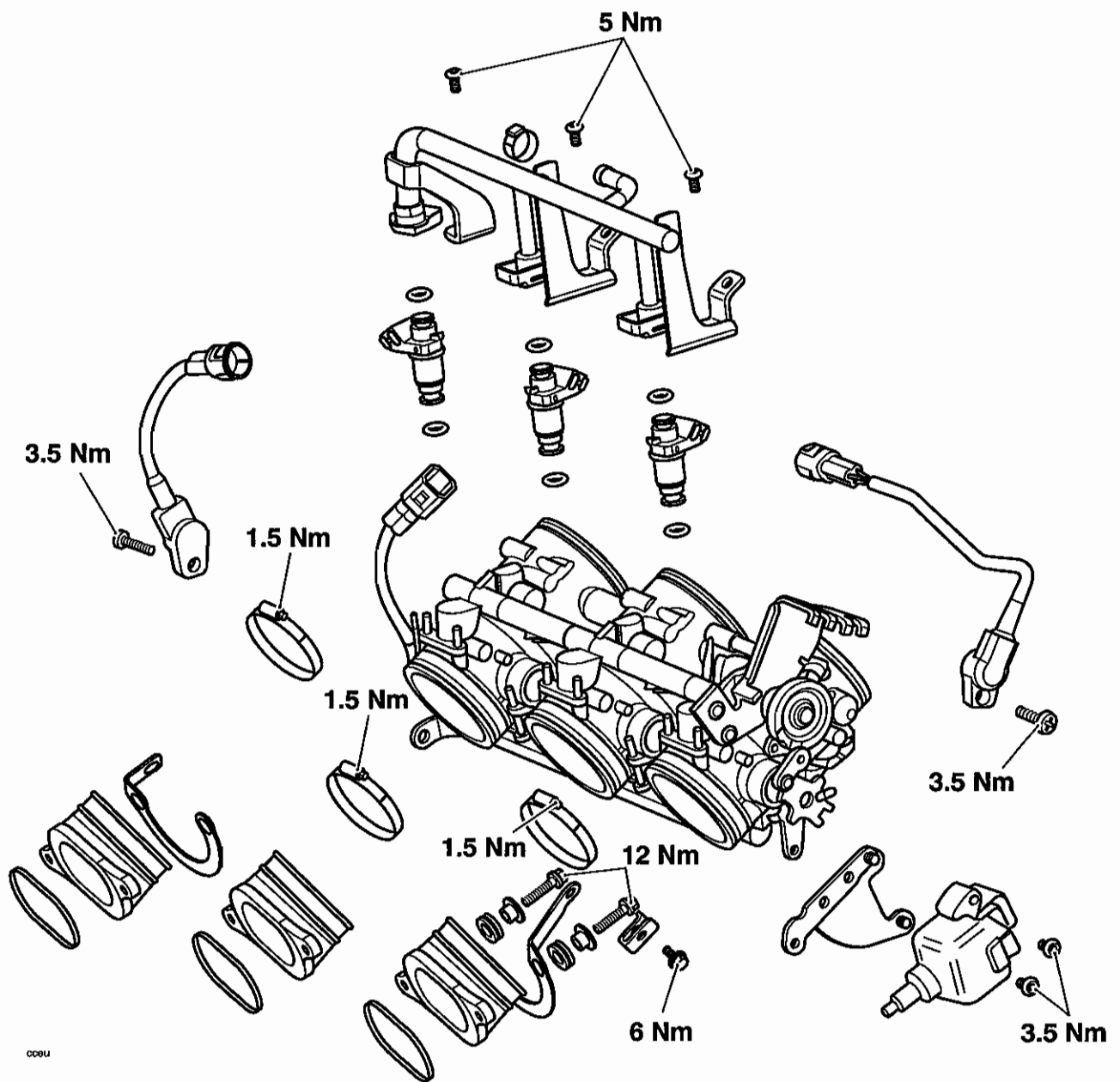

Exploded View - Airbox

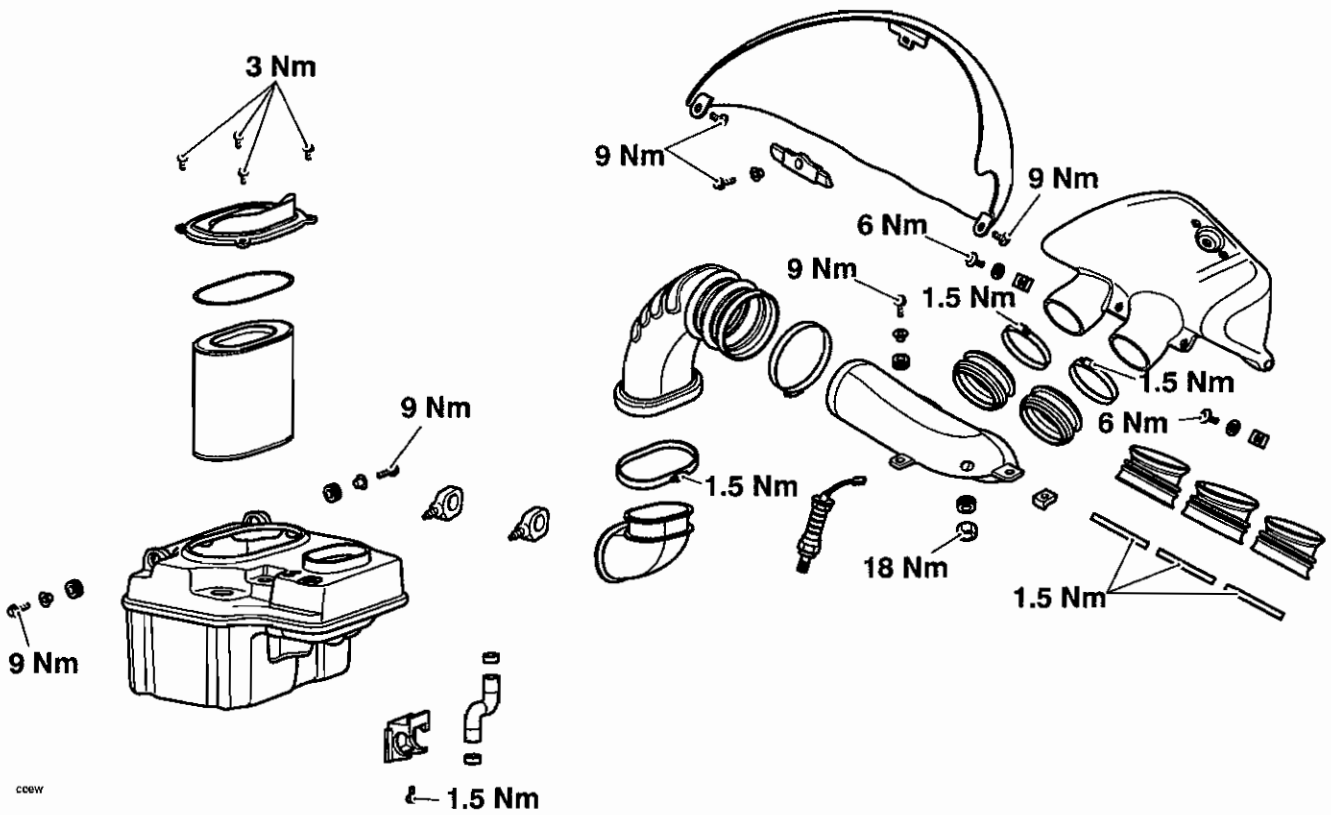

COEY

Exploded View - Exhaust System

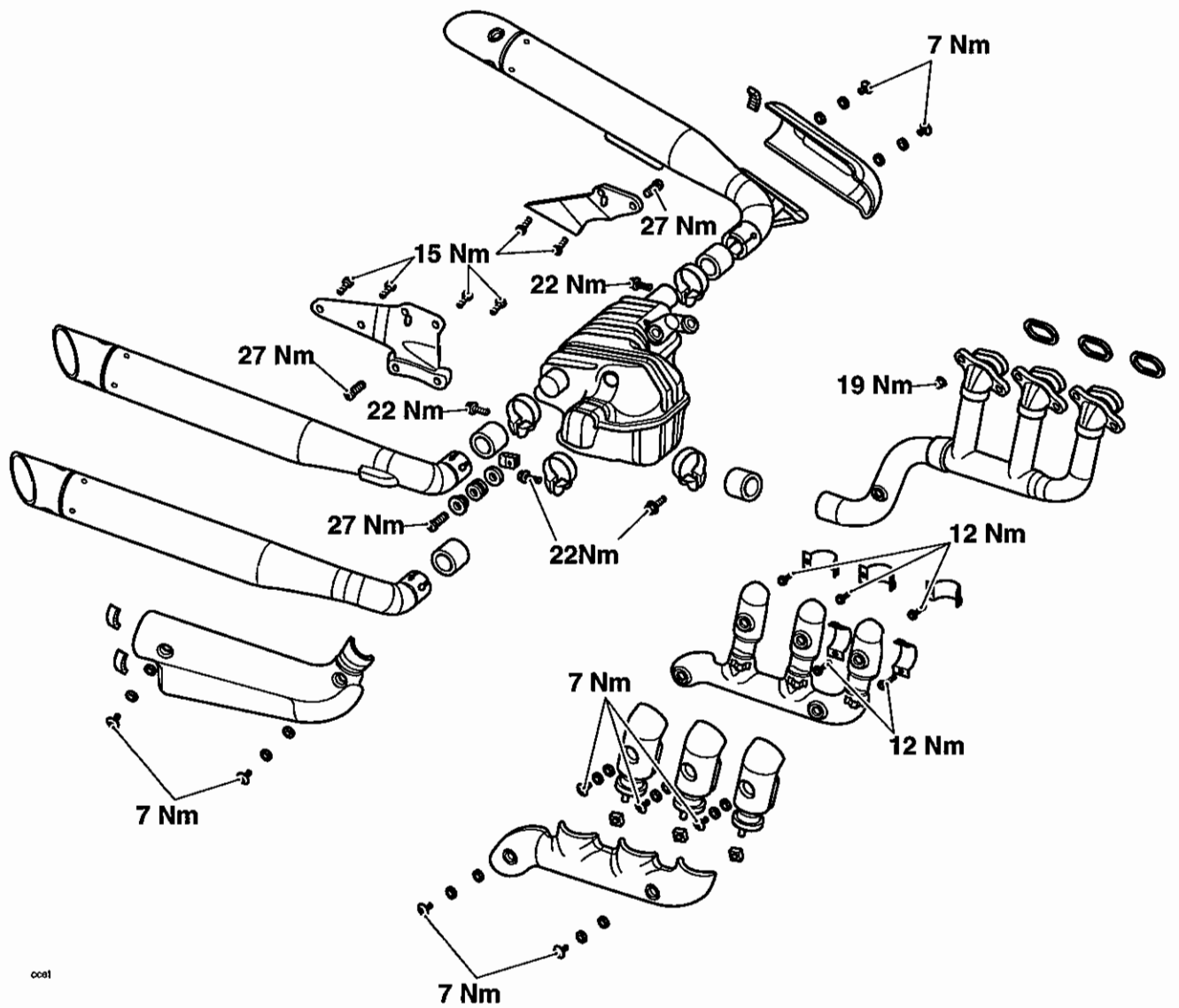

Exploded View - Evaporative System

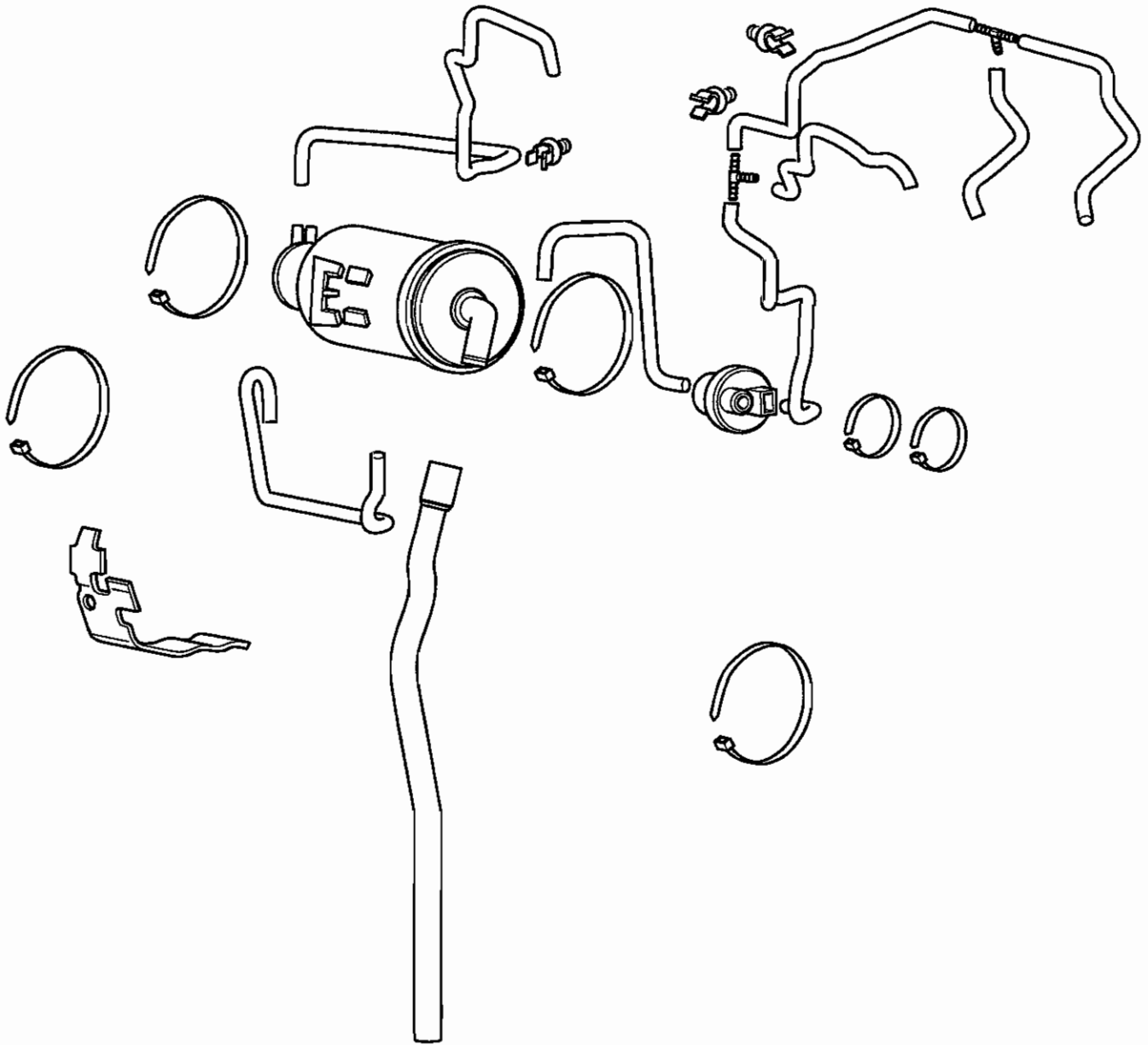

Fuel System/Engine Management

Fuel Requirements

Fuel Requirements - all countries except USA

Outside America, the Rocket III must be run on 95 RON unleaded fuel.

Fuel Requirements - USA

In the United States of America where the octane rating of fuel is measured in a different way, the following information may be applied: the Rocket III is designed to run on unleaded gasoline with a CLC or AKI octane rating $(R+M)/2$ of 89 or higher.

Caution

The use of leaded gasoline is illegal in some countries, states or territories and will invalidate the vehicle and emissions control warranties. Additionally, leaded gasoline will cause damage to emissions control components

Oxygenated Gasoline

To help in meeting clean air standards, some areas of the U.S. use oxygenated gasoline to help reduce harmful emissions. The Rocket III will give best performance when using unleaded gasoline. However, the following should be used as a guide to the use of oxygenated fuels.

Caution

Because of the generally higher volatility of oxygenated fuels, starting, engine response and fuel consumption may be adversely affected by their use. Should any of these difficulties be experienced, run the motorcycle on normal unleaded gasoline.

Ethanol

Ethanol fuel is a mixture of 10% ethanol and 90% gasoline and is often described under the names 'gasohol', 'ethanol enhanced', or 'contains ethanol'. This fuel may be used in Triumph motorcycles.

Methanol

Caution

Fuels containing methanol should not be used in Triumph motorcycles as damage to components in the fuel system can be caused by contact with methanol.

MTBE (Methyl Tertiary Butyl Ether)

The use of gasolines containing up to 15% MTBE (Methyl Tertiary Butyl Ether) is permitted in Triumph motorcycles.

Glossary of Terms

The following terms and abbreviations will be found in this section. Below is given a brief explanation of what some of the more common terms and abbreviations mean.

Air temperature

The air temperature in the air box and intake hose.

Air temperature sensor

Sensor located in the airbox to detect the temperature of the incoming air.

ATDC

After Top Dead Centre.

Barometric pressure

Pressure of the air in the airbox.

Battery voltage

The voltage at the input to the Electronic Control Module (ECM).

BTDC

Before Top Dead Centre (TDC).

Catalyst

Device placed in the exhaust system which reduces exhaust emissions by stimulating secondary combustion of the exhaust gases.

Closed throttle position

Throttle position at idle (i.e. against end stop), measured as a voltage and expressed as percentage.

Coolant temperature

The coolant temperature in the cylinder head.

Coolant temperature sensor

Sensor which detects coolant temperature.

Cooling fan status

The 'on' or 'off' condition of the cooling fan.

DTC

Diagnostic Trouble Code.

ECM

Engine Control Module.

Engine speed

The crankshaft revolutions per minute.

Freeze frame

A data set captured at the time a Diagnostic Trouble Code (DTC) is set.

Idle fuel trim

The percentage above or below the nominal fuel requirement for the volume of air entering at idle.

Idle fueling

Adjustment of fueling at idle to suit the actual air inducted.

Idle reference speed

The target idle speed as determined by the Electronic Control Module (ECM). (It should be the same as the actual idle speed if the motorcycle is operating correctly.)

Ignition advance

The timing of ignition at the spark plug relative to top dead centre.

Ignition switch position

The 'on' or 'off' position of either or both the ignition switch and the engine stop switch.

Ignition timing

Same as 'ignition advance'.

Injector pulse time

The time during which an injector remains open (i.e. delivering fuel).

Long term fuel trim

Fueling after adapting to the engine's long term fueling requirements (closed loop only). See also short term fuel trim.

Fuel System/Engine Management

MAP sensor

Manifold absolute pressure (the air pressure in the intake system).

MIL

Malfunction Indicator Lamp.

Illuminates when most Diagnostic Trouble Codes (DTC's) are set.

Neutral switch status

The 'neutral' or 'in gear' status of the gearchange.

Off idle fuel trim

The percentage above or below the nominal fuel requirement for the volume of air entering at engine speeds other than idle. This function is not currently used in the Triumph system.

Open circuit

A break in an electrical circuit - current cannot flow.

Over temp

High temperature within the Electronic Control Module (ECM) caused by an internal or external failure.

Primary Throttle Position Sensor

Sensor for the primary (lower) throttle position.

Primary Throttle Stepper Motor

Stepper motor used to vary throttle opening at idle and when the engine is cold.

Purge valve duty cycle

The time the purge valve is open in an open / close cycle, expressed as a percentage of the cycle time.

Road Speed Sensor

Gearbox mounted sensor which delivers information to the ECM that is converted to the road speed value that is displayed on the speedometer.

Second Throttle Position Sensor

Sensor for the second (upper) throttle position.

Second Throttle Stepper Motor

Stepper motor used to vary all second throttle positions, on or off idle.

Sensor reference voltage

Supply voltage to the system sensors (nominally 5 volts).

Short circuit

A 'short cut' in an electrical circuit - current by-passes the intended circuit (usually to earth).

Short term fuel trim

A correction applied to the fuel mixture during closed loop catalyst operation. This, in turn has an effect on the long term fuel trim in that, if an engine constantly requires mixture correction, the long term fuel trim will adapt to this requirement thus reducing the need for constant short term adjustment.

Sidestand status

The 'up' or 'down' position of the side stand.

Target dwell time

The actual time from coil 'on' to coil 'off'.

Throttle position

The position of the throttle butterfly given as a percentage of the movement range. When the data is displayed on the tool, fully open need not be 100% nor fully closed 0%.

Throttle voltage

Voltage at the throttle potentiometer.

Vbatt

Battery voltage.

Engine Management System

System Description

The Rocket III is fitted with an electronic engine management system which encompasses control of both ignition and fuel delivery. The electronic control module (ECM) draws information from sensors positioned around the engine, cooling and air intake systems and precisely calculates ignition advance and fueling requirements for all engine speeds and loads.

In addition, the system has an on-board diagnostic function. This ensures that, should a malfunction occur in the engine management system, the malfunction type, and engine data at the time the malfunction occurred, are stored in the ECM memory. This stored data can then be recovered using a special service tool which is mandatory for all Triumph dealers. In this way, precise diagnosis of a fault can be made and the fault quickly rectified.

System Sensors

- **Intake air temperature sensor** - situated at the front of the intake duct, above the cam cover. As the density of the air (and therefore the amount of oxygen available to ignite the fuel) changes with temperature, an intake air temperature sensor is fitted. Changes in air temperature (and therefore air density) are compensated for by adjusting the amount of fuel injected to a level consistent with clean combustion and low emissions.
- **Barometric pressure sensor** - situated beneath the motorcycle seat, in the top of the airbox. The barometric pressure sensor measures atmospheric air pressure. With this information, the amount of fuel per injection is adjusted to suit the prevailing conditions.
- **Manifold Absolute Pressure (MAP) sensor** - situated at the front of the intake duct, above the cam cover, connected to each of the three throttle bodies by equal length tubes. The MAP sensor provides information to the ECM which is used at shallow throttle angles (very small throttle openings) to provide accurate engine load indications to the ECM. This degree of engine load accuracy allows the ECM to make very small adjustments to fuel and ignition which would otherwise not be possible from throttle angle data alone.
- **Clutch switch** - situated on the clutch lever. The clutch must be pulled in for the starter motor to operate.
- **Crankshaft position sensor** - situated in the alternator cover. The crankshaft position sensor detects movement of a toothed wheel attached to the alternator rotor.

The toothed wheel gives a reference point from which the actual crankshaft position is calculated. The crankshaft position sensor information is used by the ECM to determine engine speed and crankshaft position in relation to the point where fuel is injected and ignition of the fuel occurs.
- **Engine coolant temperature sensor** - situated towards the front of the cylinder head, on the left hand side. Coolant temperature information, received by the ECM, is used to optimise fueling at all engine temperatures and to calculate hot and cold start fueling requirements.
- **Primary throttle position sensor** - situated at the rear of the lower throttle spindle. Used to relay throttle position information to the ECM. Throttle opening angle is used by the ECM to determine fueling and ignition requirements for all throttle positions.
- **Secondary throttle position sensor** - situated at the front of the upper throttle spindle. Used to relay secondary throttle position information to the ECM. Secondary throttle angle is used by the ECM to determine secondary throttle opening position under all engine running conditions.
- **Road speed sensor** - situated in the lower crankcase, on the left hand side. The road speed sensor provides the ECM with data from which road speed is calculated and displayed on the speedometer. A vehicle speed limitation device also receives information from the road speed sensor.
- **Lambda sensor** - situated in the exhaust header system upstream of the catalyst box. The lambda sensor constantly feeds information to the ECM on the content of the exhaust gases. Based on this information, adjustments to air/fuel ratio are made.
- **Side stand switch** - situated at the top of the sidestand leg. If the sidestand is in the down position, the engine will not run unless the transmission is in neutral.

Fuel System/Engine Management

Sensor Locations

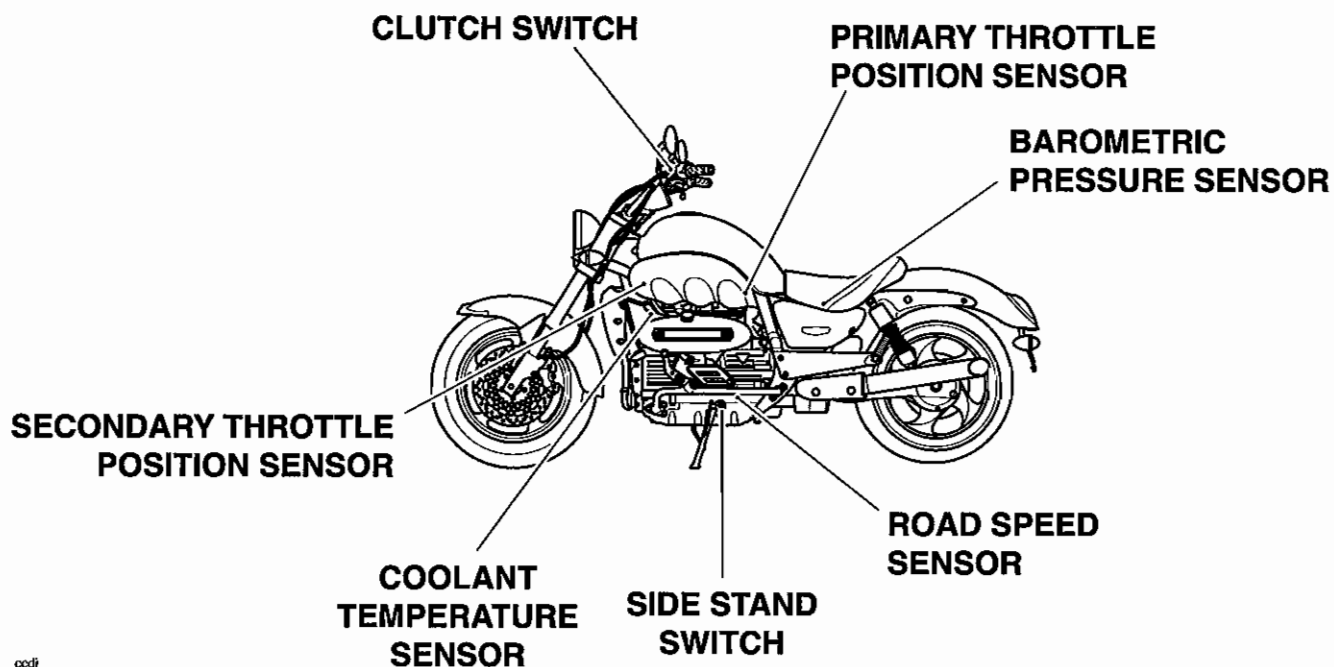

ccdj

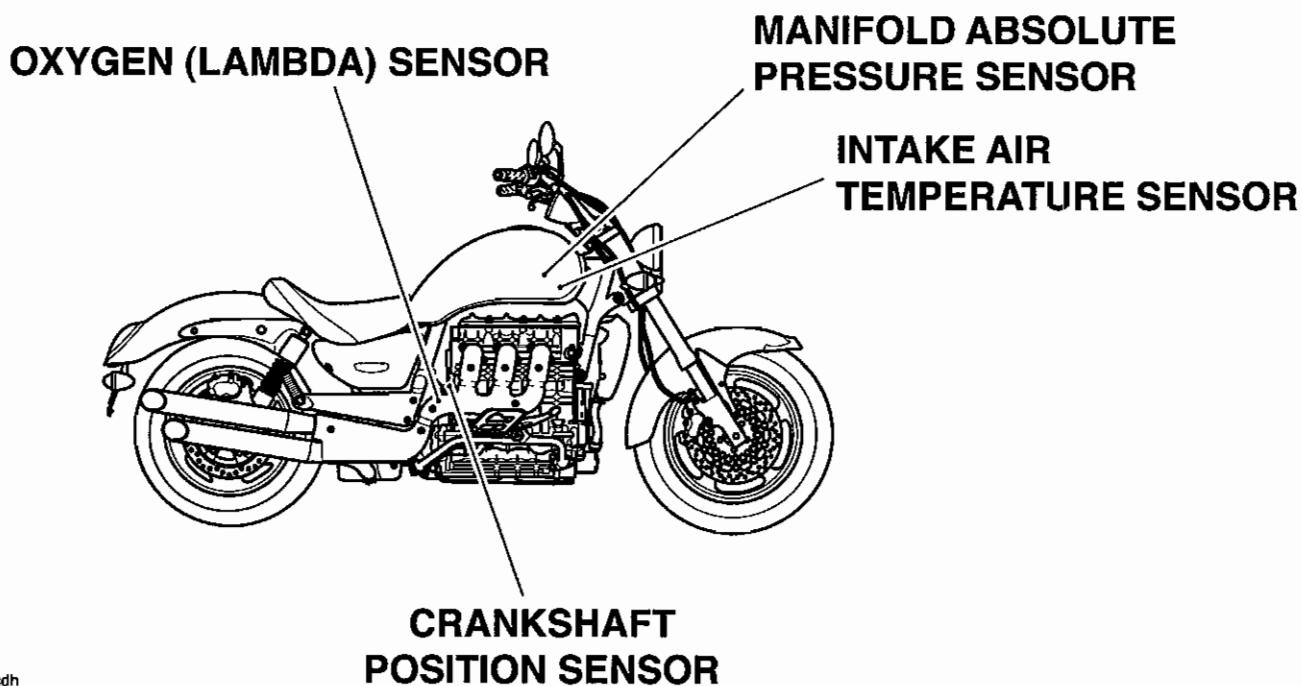

ccdh

Fuel System/Engine Management

System Actuators

In response to signals received from the sensors, the ECM controls and directs messages to a series of electronic and electro-mechanical actuators. The function and location of the actuators is given below.

- **Primary throttle stepper motor** - situated at the front of the throttle bodies. The primary throttle stepper actuates a cam/lever which causes variations in the closed throttle position. Although used primarily to ensure target idle speed is maintained, it also increases throttle opening when the engine is cold.
- **Second throttle stepper motor** - situated between the throttle bodies for numbers one and two cylinders. In response to direction from the ECM, the second throttle stepper motor moves the second throttle spindle to the position directed by the ECM. The second butterfly optimises engine torque by maintaining intake air flow speed. It does not act as a choke for cold start purposes.
- **Canister purge valve (California models only)** - situated in the vapour return line between the carbon canister and the throttle bodies. The purge valve controls the return of vapour which has been stored in the carbon canister during the period when the engine is switched off. The valve is 'pulsed' by the ECM to give control over the rate at which the canister is purged.
- **Injectors** - located in the throttle body assembly. The engine is fitted with three injectors. The spray pattern of the injectors is fixed but the length of time each injector can remain open is variable according to operating conditions. The duration of each injection is calculated by the ECM using data received from the various sensors in the system.
- **Ignition coils** - mounted on a bracket, above the cam cover. There are three coils fitted, one for each pair of spark plugs. The ECM controls the point at which the coils are switched on and off. In calculating the switch-on time, the ECM allows sufficient time for the coils to charge to a level where a spark can be produced. The coils are switched off at the point of ignition, the timing of which is optimised for good engine performance.
- **Fall detection switch** - situated behind the left hand side cover. The fall detection switch will detect if the motorcycle is on its side and will cut power to the ECM immediately. This prevents the engine from running and the fuel pump from delivering fuel. In the event of a fall, the switch is reset by returning the bike to an upright position and switching the ignition off then back on again.

- **Main power relay** - situated behind the left hand side cover. When the ignition is switched on, the main power relay is powered up to provide a stable voltage supply for the ECM.
- **Fuel pump** - located inside the fuel tank. The electric pump delivers fuel into the fuel system, via a pressure regulator, at a constant 3 bar pressure. The pump is run continuously when the engine is operating and is also run briefly when the ignition is first switched on to ensure that 3 bar is available to the system as soon as the engine is cranked. Fuel pressure is controlled by a regulator also situated inside the fuel tank.
- **Cooling fan** - located behind the radiator. The ECM controls switching on and off of the cooling fan in response to a signal received from the coolant temperature sensor. When the coolant temperature rises to a level where the cooling effect of natural airflow is insufficient, the cooling fan is turned on by the ECM. When the coolant temperature falls sufficiently, the ECM turns the cooling fan off. The fan only becomes operational when the engine is running. It will not operate at any other time.

Note:

- **In this system, the starter lockout system (clutch switch, neutral switch, sidestand switch) all operate through the engine management ECM.**

Fuel System/Engine Management

Actuator Locations

**PRIMARY & SECONDARY
THROTTLE STEPPER MOTORS**

INJECTORS

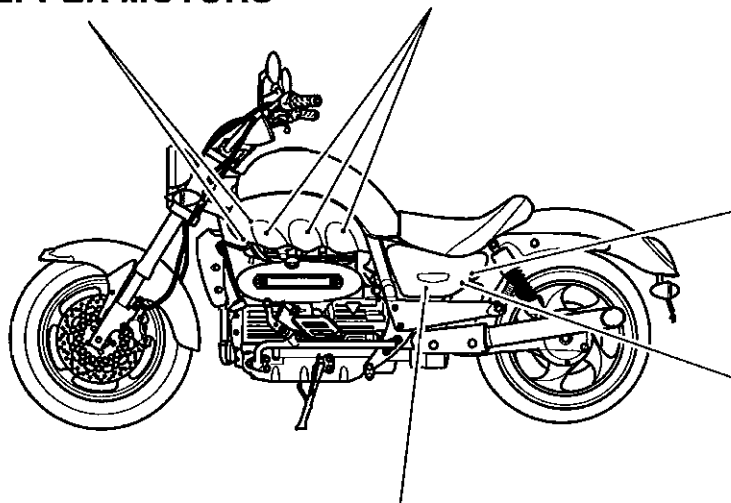

**FALL DETECTION
SWITCH**

**MAIN POWER
RELAY**

**CANISTER PURGE
VALVE**

ccdl

FUEL PUMP

COOLING FAN

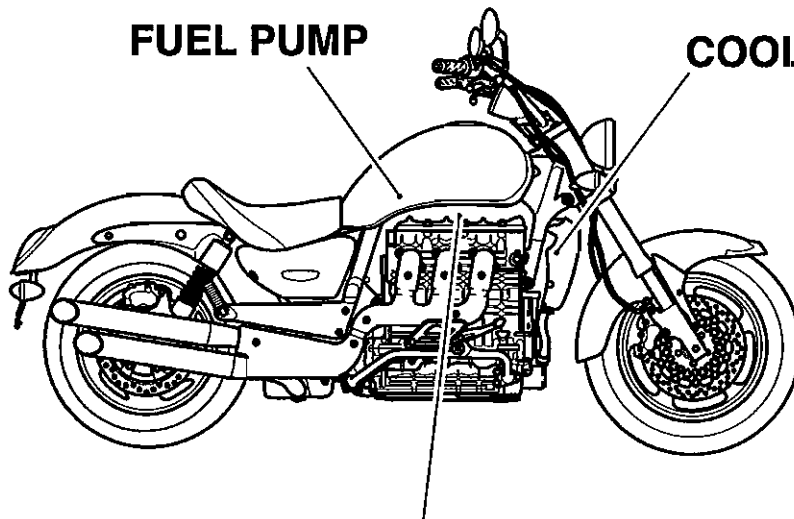

IGNITION COILS

ccdg

Engine Management Circuit Diagram - Rocket III

Key To Wiring Circuit Diagram

| Key | Item Description |
|-----|-------------------------------------|
| 1 | Engine Control Module |
| 2 | Diagnostic Connector |
| 3 | Vehicle Speed Sensor |
| 4 | Sidestand Switch |
| 5 | Instrument Assembly |
| 6 | Accessory Fuel Gauge |
| 7 | Gear Position Sensor |
| 8 | Clutch Switch |
| 9 | Starter Relay |
| 10 | Fall Detection Sensor |
| 11 | Air Pressure Sensor |
| 12 | MAP Sensor |
| 13 | Inlet Air Temperature Sensor |
| 14 | Lambda Sensor |
| 15 | Cooling Fan |
| 16 | Fuel Pump and Level Sender Assembly |
| 17 | Fuel Pump Relay |
| 18 | Cooling Fan Relay |
| 19 | Fuse Box (Fuse 7) |
| 20 | Ignition Coils |
| 21 | Evaporative Purge Valve |
| 22 | Throttle Position Sensor |
| 23 | Second Throttle Position Sensor |
| 24 | Inlet Air Temperature Sensor |
| 25 | Idle Speed Control Stepper Motor |
| 26 | Second Throttle Actuator |
| 27 | Fuel Injectors |
| 28 | Engine Harness Connector |
| 29 | Engine Management System Relay |
| 30 | Crankshaft Sensor |

Key To Wiring Colour Codes

| Code | Wiring Colour |
|------|---------------|
| B | Black |
| U | Blue |
| N | Brown |
| G | Green |
| S | Slate/Grey |
| O | Orange |
| K | Pink |
| R | Red |
| P | Purple |
| W | White |
| Y | Yellow |
| LG | Light Green |
| LU | Light Blue |

ECM Connector Pin Numbering

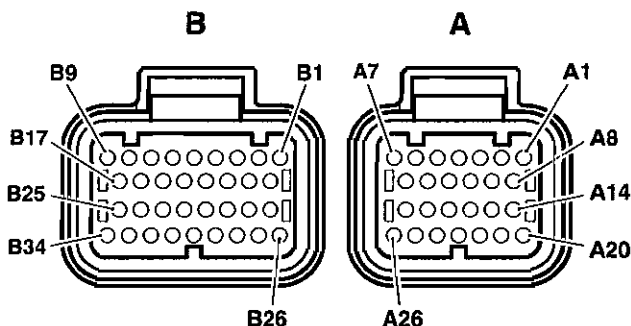

cbhs

The above illustration shows the pin numbering system used in the engine management circuit diagram.

The small connector's pins are prefixed A and the large connector's pins B. As viewed on the mating face with the ECM (as per the illustration), pins are numbered from right to left with number one in the top right corner.

Circuit Diagram - Engine Management System - Rocket III

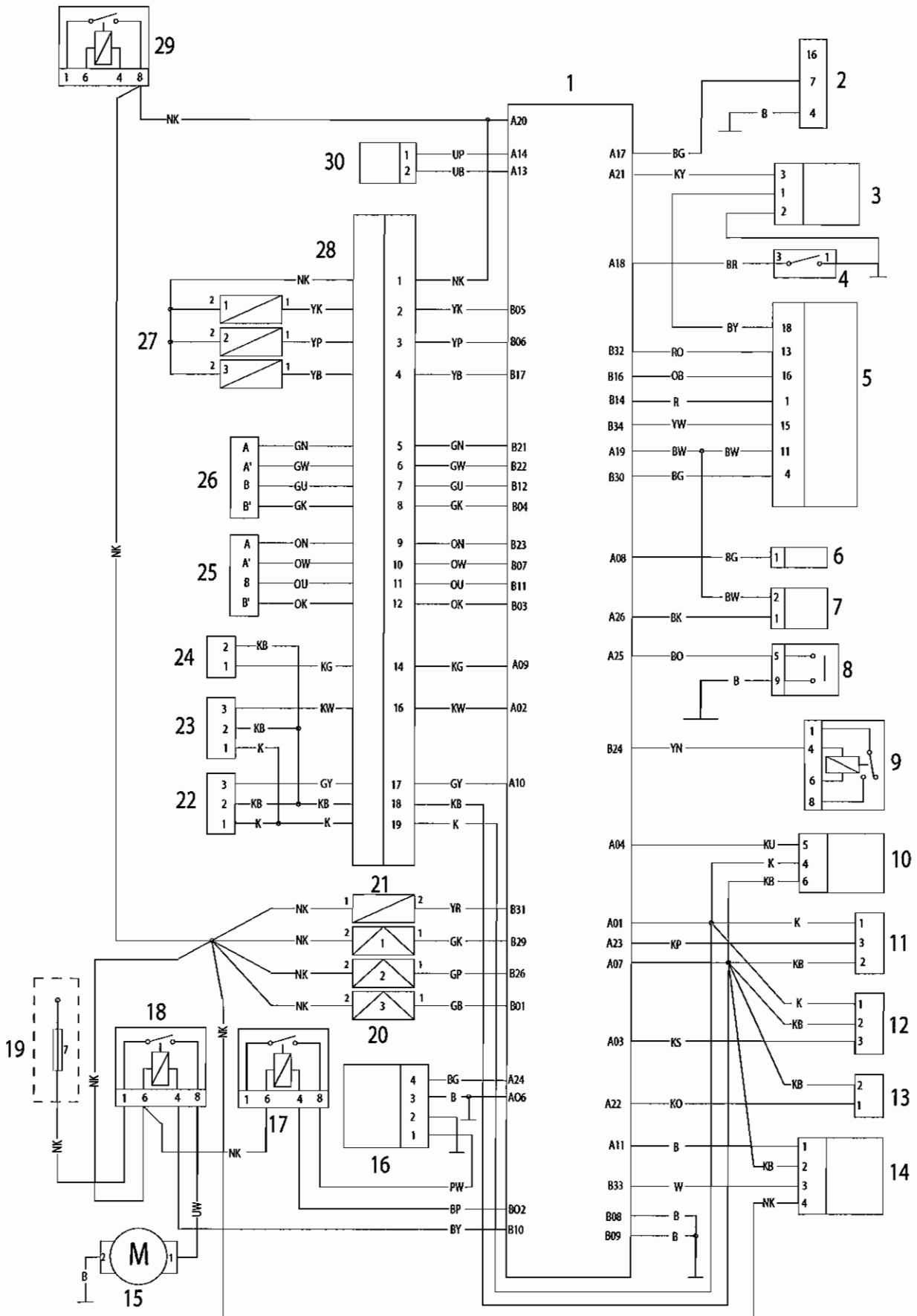

System Diagnostics

The engine management system has an on-board diagnostics feature which allows service technicians to retrieve stored data from the ECM using a Triumph service tool. **Full details of the tool's operation and how to interpret the results are given elsewhere in this section.**

The tool is connected to the motorcycle using a dedicated diagnostic plug situated beneath the seats. By using a dedicated plug, no electrical connectors associated with the system are disturbed, reducing potential connector damage.

The tool allows the user to retrieve data associated with the system sensors and actuators, test various component functions, read build data and make minor adjustments to the set-up of the system. The data and tests available are described on the following pages.

On-board Fault Detection System

The on-board diagnostic system has two stages to fault detection. When a fault is detected, the DSM (Diagnostic Status Manager) raises a flag to indicate that a fault is present and increments a counter. The counter checks the number of instances that the fault is noted. For example, if there is a fault in the crankshaft position sensor, the counter will increment its count each time the crankshaft turns through 360°, provided the fault is still present.

When the count begins, the fault is detected but not confirmed. If the fault continues to be detected and the count reaches a pre-determined threshold, the fault becomes confirmed. If the fault is an emissions related fault or a serious malfunction affecting engine performance, a DTC (Diagnostic Trouble Code) and freeze-frame data will be logged in the ECM's memory and the MIL (Malfunction Indicator Lamp) on the motorcycle instrument panel is illuminated. Once a fault is confirmed, the number of warm-up cycles made by the engine is counted. If the fault clears, the warm-up cycle counter will extinguish the MIL (Malfunction Indicator Lamp) at a pre determined count, and erase the DTC and freeze frame data from the ECM memory at another (higher) count.

A single warm-up cycle is deemed to have taken place when the following criteria have been met:

- The coolant temperature must be raised to 72°C or more.
- The coolant temperature must have risen by 23°C or more from its start temperature, when 72°C is reached.
- A controlled power-down sequence must take place.

Note:

- When a fault has been rectified, the MIL will remain illuminated until sufficient non-fault warm-up cycles have taken place to turn it off. The MIL will be immediately extinguished if, after first rectifying the fault, the DTC (diagnostic trouble code) that caused the MIL illumination is erased from the ECM memory using the Triumph diagnostic tool.

Note:

- In most cases, when a fault is detected, the engine management system will revert to a 'limp-home' mode. In this mode, the engine will still function though the performance and fuel economy may be marginally affected. In some cases, the rider may not notice any appreciable difference from normal operation.



Triumph Diagnostic Tool

Described on the following pages is the range of information which can be retrieved from the ECM's memory and the adjustments which can be performed using the Triumph service diagnostic tool.

The tables indicate which tests are performed by the on-board system and what information can be retrieved by the Triumph diagnostic tool.

Full details of how to operate the tool and how to interpret the data follow later in this section.

Fuel System/Engine Management

Current Data

By using the Triumph diagnostic tool, live engine data (engine running) can be recovered from the motorcycle. The data available is:

| Function Examined | Result Reported (Scale) |
|-------------------------------------|-------------------------------|
| Engine speed | RPM |
| Calculated load | % |
| Coolant temperature | °C |
| Short term fuel trim | % |
| Throttle Position | % |
| Intake air temperature | °C |
| Vehicle speed | km/h |
| Ignition Advance | degrees |
| Heated oxygen sensor output voltage | volts |
| Intake manifold absolute pressure | mm/hg |
| Fuel system status | open or closed loop operation |

Freeze-frame Data

Freeze frame data is stored at the time a DTC is recorded (confirmed) by the ECM. If multiple DTCs are recorded, the freeze-frame data which is stored will relate to the first recorded DTC only.

By calling up freeze frame data associated with the first recorded DTC, the technician can check the engine condition at the time the fault occurred. The data available is:

| Function Examined | Result Reported (Scale) |
|-------------------------------------|-------------------------------|
| Engine speed | RPM |
| Calculated load | % |
| Coolant temperature | °C |
| Short term fuel trim | % |
| Throttle Position | % |
| Intake air temperature | °C |
| Vehicle speed | km/h |
| Ignition Advance | degrees |
| Heated oxygen sensor output voltage | volts |
| Intake manifold absolute pressure | mm/hg |
| Fuel system status | open or closed loop operation |

Fuel System/Engine Management

Function Tests

The system allows the diagnostic tool to perform a series of function tests on various actuators in the engine management system. In some cases it is necessary to make a visual observation of a component and in other, if faults are present, DTCs will be logged.

The function tests available are:

| Function Examined | Report Method |
|------------------------------------|---------------------------------------|
| Instrument panel | Visual inspection of instruments |
| Idle speed control stepper motor | Stored fault code* |
| Purge control valve | Stored fault code* |
| Fuel pump relay | Stored fault code* |
| Fuel pump operation | Stored fault code*/Fuel pressure test |
| Cooling fan | Stored fault code*/fan operation |
| 2nd throttle control stepper motor | Stored fault code* |

* If a fault is detected.

Checks/Adjustments

Adjustments

Using the Triumph diagnostic tool, it is possible to reset the ECU to the factory default settings and to balance the throttle bodies.

Further facilities are provided to allow correct replacement/adjustment of the primary throttle position sensor and the primary throttle stepper motor. These facilities are needed as, after replacement of the parts concerned, adjustments have to be made to specific voltage settings, all with the throttles in a specific position.

Full details of these procedures are provided later in this section.

Adaption status

Because the fuel system is adaptive, the tool is able to automatically adjust to new working conditions. This screen displays information as to the adaption status of the vehicle which will show if it has adapted or not.

| Function Examined | Report Method |
|---|---------------------|
| Closed throttle position reference status | adapted/not adapted |
| Idle speed control adaption status | % |
| Oxygen sensor adaption status (off idle) | % |
| Oxygen sensor adaption range (off idle) | % |
| Oxygen sensor adaption status (idle) | % |
| Oxygen sensor adaption range (idle) | % |

Build data

The following items of build data can also be read.

| Function Examined |
|---------------------------------------|
| Vehicle identification Number (VIN) |
| Triumph ECM part number |
| ECM manufacturer's part number |
| ECM serial number |
| Software version number (tune number) |

Fuel System/Engine Management

Checks

When using this function it is possible to check the status of various sensors and actuators and also check certain items of factory data logged during vehicle assembly.

The data sets are divided into three groups, voltages/pressures, throttles/coils/injectors and other data

The data available under voltages is:

| Item Checked | Result Unit |
|---|-------------|
| Throttle position sensor voltage | Volts |
| Throttle position | % open |
| Manifold absolute pressure sensor voltage | Volts |
| Manifold absolute pressure (one reading per cylinder) | mmHg |
| Atmospheric pressure sensor voltage | Volts |
| Atmospheric pressure | mmHg |
| Battery voltage | Volts |
| Battery voltage scaling | Volts |
| Coolant temperature sensor voltage | Volts |
| Air temperature sensor voltage | Volts |
| Oxygen sensor voltage | Volts |
| Oxygen sensor reading | Volts |
| 2nd throttle position sensor voltage | Volts |
| 2nd throttle position | % open |
| Gear position sensor voltage | Volts |
| Fuel level sensor voltage | Volts |
| Fall detection switch voltage | Volts |
| Fuel sensor voltage | Volts |

The data available under throttles/coils/injectors is:

| Item Checked | Result Unit |
|----------------------------|--------------|
| 2nd throttle current steps | numeric |
| 2nd throttle target steps | numeric |
| Injector 1 pulse time | milliseconds |
| Injector 2 pulse time | milliseconds |
| Injector 3 pulse time | milliseconds |
| Injector 4 pulse time | milliseconds |
| Ignition timing cyl 1 | degrees BTDC |
| Ignition timing cyl 2 | degrees BTDC |
| Ignition timing cyl 3 | degrees BTDC |
| Ignition timing cyl 4 | degrees BTDC |
| Coil 1 dwell time | milliseconds |
| Coil 2 dwell time | milliseconds |
| Coil 3 dwell time | milliseconds |
| Coil 4 dwell time | milliseconds |

The data available under 'other' is:

| Item Checked | Result Unit |
|------------------------------------|----------------|
| Malfunction indicator light status | MIL off/on |
| Fan relay status | Fan off/on |
| Starter relay status | Starter on/off |
| Fall detection status | Normal/over |
| Oxygen sensor heater status | Heater on/off |
| Secondary air injection status | SAI on/off |
| Engine rpm | RPM |
| Vehicle speed | km/h |
| Short term fuel trim | +/-100% |
| Calculated load | % |
| Idle reference speed | RPM |
| Idle speed control target steps | numeric |
| Purge valve duty cycle | % |
| Gear position | numeric value |
| Neutral switch | Gear/neutral |
| Low fuel alarm status | On/off |

Fuel System/Engine Management

Diagnostic Trouble Codes

Diagnostic trouble codes (DTCs) are logged in the ECM memory when there is a confirmed fault in the system. The codes are reported to the Triumph diagnostic tool as a four digit code.

As mentioned earlier, when the system detects a fault, it begins to count the number of times the fault occurs before illuminating the MIL and storing a fault code.

Similarly, if a fault clears, the ECM also records this fact and will turn off the MIL when sufficient no-fault warm-up cycles have taken place. Any fault codes will remain in the ECM memory until the required number of no-fault warm-up cycles have taken place. The number of warm-up cycles required to extinguish the MIL will always be less than the number required to remove a DTC from the ECM memory. DTCs can be removed at any time using the Triumph diagnostic tool

The system will log the diagnostic trouble codes listed below/over:

| Diagnostic Trouble Code (DTC) | Fault Description | Number of no-fault cycles before turning off MIL | Number of no-fault cycles before DTC is erased | MIL illuminated when fault is logged |
|-------------------------------|--|--|--|--------------------------------------|
| P0201 | Injector 1 circuit malfunction | 3 | 40 | Yes |
| P0202 | Injector 2 circuit malfunction | 3 | 40 | Yes |
| P0203 | Injector 3 circuit malfunction | 3 | 40 | Yes |
| P1201 | Injector 1 open circuit/short to ground | 3 | 40 | Yes |
| P1202 | Injector 2 open circuit/short to ground | 3 | 40 | Yes |
| P1203 | Injector 3 open circuit/short to ground | 3 | 40 | Yes |
| P0335 | Crankshaft sensor circuit malfunction | 3 | 40 | Yes |
| P0032 | Oxygen sensor heater short circuit to battery | 3 | 40 | Yes |
| P0031 | Oxygen sensor heater open circuit/short to ground | 3 | 40 | Yes |
| P0030 | Oxygen sensor heater circuit malfunction | 3 | 40 | Yes |
| P0136 | Oxygen sensor circuit malfunction | 3 | 40 | Yes |
| P0122 | Throttle position sensor low input | 3 | 40 | Yes |
| P0123 | Throttle Position sensor high input | 3 | 40 | Yes |
| P0107 | Manifold absolute pressure sensor low voltage | 3 | 40 | Yes |
| P0108 | Manifold absolute pressure sensor high voltage | 3 | 40 | Yes |
| P1105 | Manifold absolute pressure sensor pipe malfunction | 3 | 40 | Yes |
| P1107 | Ambient air pressure sensor circuit low voltage | 3 | 40 | Yes |
| P1108 | Ambient air pressure sensor circuit high voltage | 3 | 40 | Yes |
| P0112 | Intake air temperature too high | 3 | 40 | Yes |
| P0113 | Intake air temperature too low | 3 | 40 | Yes |
| P0117 | Engine coolant temperature too high | 3 | 40 | Yes |
| P0118 | Engine coolant temperature too low | 3 | 40 | Yes |
| P0500 | Vehicle speed sensor malfunction | 3 | 40 | Yes |

Fuel System/Engine Management

| Diagnostic Trouble Code (DTC) | Fault Description | Number of no-fault cycles before turning off MIL | Number of no-fault cycles before DTC is erased | MIL illuminated when fault is logged |
|-------------------------------|--|--|--|--------------------------------------|
| P1552 | Cooling fan short circuit/open circuit | 3 | 40 | Yes |
| P1553 | Cooling fan short to battery voltage/over temperature | 3 | 40 | Yes |
| P1231 | Fuel pump short circuit to ground or open circuit | 3 | 40 | Yes |
| P1232 | Fuel pump relay short circuit to battery | 3 | 40 | Yes |
| P0444 | Purge valve system short circuit to ground or open circuit | 3 | 40 | Yes |
| P0445 | Purge valve system short circuit to battery | 3 | 40 | Yes |
| P0617 | Starter relay short circuit to battery | 3 | 40 | Yes |
| P0616 | Starter relay short circuit to ground or open circuit | 3 | 40 | Yes |
| P0414 | Secondary air injection system short circuit to battery | 3 | 40 | Yes |
| P0413 | Secondary air injection system short circuit to ground or open circuit | 3 | 40 | Yes |
| P0222 | 2nd throttle position sensor system low voltage | 3 | 40 | Yes |
| P0223 | 2nd throttle position sensor high voltage | 3 | 40 | Yes |
| P0638 | 2nd throttle circuit malfunction | 3 | 40 | Yes |
| P0505 | Idle speed control system malfunction | 3 | 40 | Yes |
| P1631 | Fall detection sensor circuit low voltage | 3 | 40 | Yes |
| P1632 | Fall detection sensor circuit high voltage | 3 | 40 | Yes |
| P0560 | System voltage - battery circuit malfunction | 3 | 40 | Yes |
| P1500 | Vehicle speed output circuit malfunction | 0 | 40 | No |
| P0654 | Tachometer circuit malfunction | 0 | 40 | No |
| P1115 | Coolant temperature gauge circuit malfunction | 0 | 40 | No |
| P0460 | Fuel level sensor circuit malfunction | 0 | 40 | No |
| P0705 | Gear position sensor circuit malfunction | 0 | 40 | No |
| P0656 | Fuel gauge circuit malfunction | 0 | 40 | No |
| P1610 | Low fuel output circuit malfunction | 0 | 40 | No |
| P0630 | EEPROM fault | 0 | 40 | No |

Fuel System/Engine Management

Service Diagnostic Tool

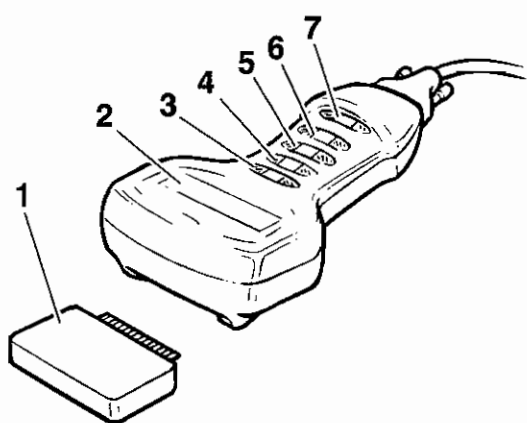

gaj/c

1. Memory card
2. Screen
3. Return key
4. Up key
5. Down key
6. Validate key
7. Help key

The memory card (1) contains all the information necessary to allow the technician to follow a number of different paths to:

- Diagnose faults
- Obtain data
- Make checks / adjustments

It is removable to allow replacement / update cards to be inserted.

The screen comprises four horizontal lines and twenty vertical columns forming a series of boxes into which letters and numbers can be displayed to provide the necessary question, message, answer etc.

At the left of the screen, one or more symbols as detailed below may be displayed.

| | | | | | | | | | | | | | | | | | | | | | |
|---|--|--|---|---|---|---|---|---|---|---|---|---|---|---|---|---|---|---|---|---|---|
| | | | | | | | | | | | D | I | A | G | N | O | S | T | I | C | S |
| | | | | C | U | R | R | E | N | T | | D | A | T | A | | | | | | |
| ▶ | | | R | E | A | D | | S | T | O | R | E | D | | D | T | C | S | | | |
| ▼ | | | F | U | N | C | T | I | O | N | | T | E | S | T | S | | | | | |

Typical screen showing symbol examples

▲▼ Cursors to indicate that further lines of text are available to be seen above and/or below those already in view, by scrolling the text up or down using the 'Up' or 'Down' keys.

▶ Cursor to show which line of text is 'active'.

? Indicates further help/guidance information available on that line by pressing the help key.

Tool Keys

In most cases, the **Return** key (↵) enables the user to return to the screen last displayed.

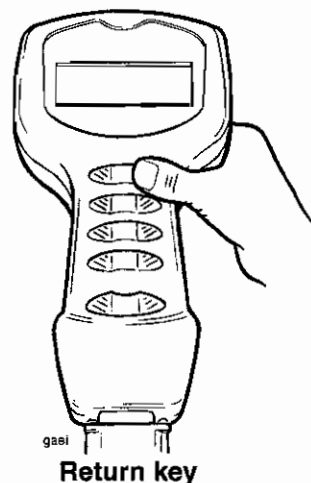

The **Up** and **Down** keys - press to move the lines of text up or down. They are also used to enter the Dealer number and the date.

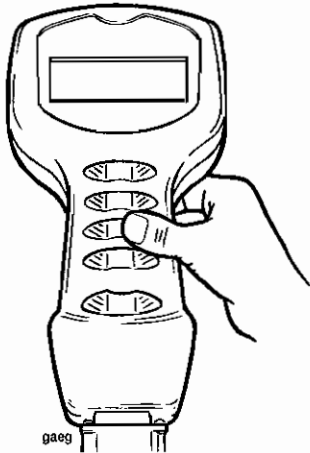

Up/down keys (2 separate keys)

Press the **Validation** key (*) to move on to the next message.



Validation key

The **Help** key can be used when the '?' symbol shows, to get more information about that line of text. To return to the diagnostic screen from the help area, press the help '?' button again.

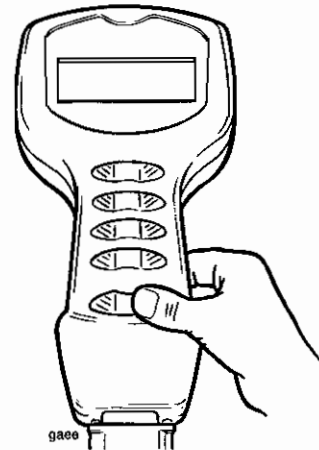

Help key

Test Procedure

The following describes the procedure to follow when using the service diagnostic tool. It does not cover the further diagnosis that must be carried out once a fault area has been identified. For details of the procedure to follow when a fault area or fault code has been identified, refer to the diagnosis details later in this section.

Note:

- The tool does not retain any memory of faults, diagnosis etc. carried out on any particular motorcycle. Any such memory is only retained in the motorcycle's ECM.
- The following five pages describe the tool operations in flow chart form.

Fuel System/Engine Management

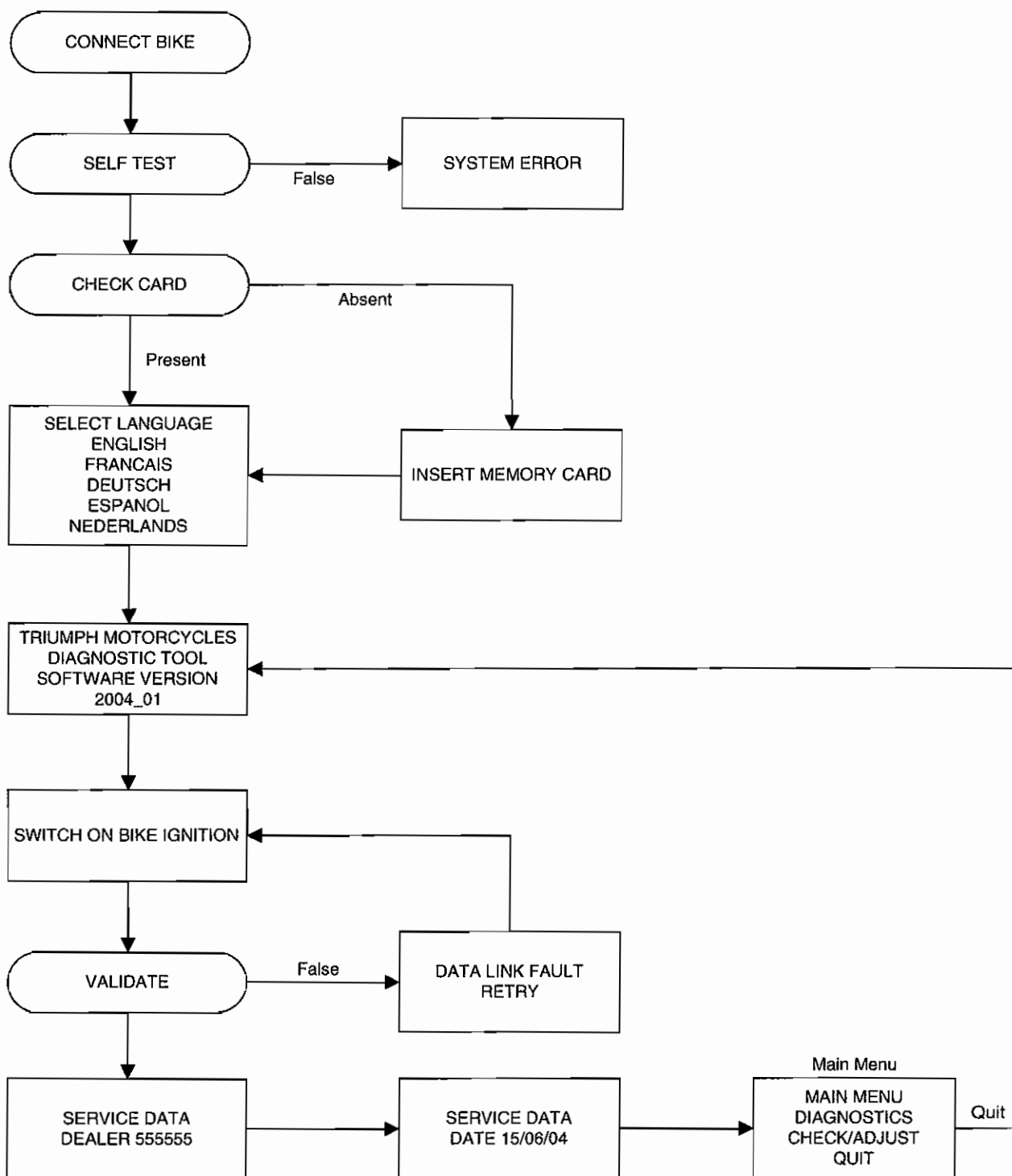

Fuel System/Engine Management

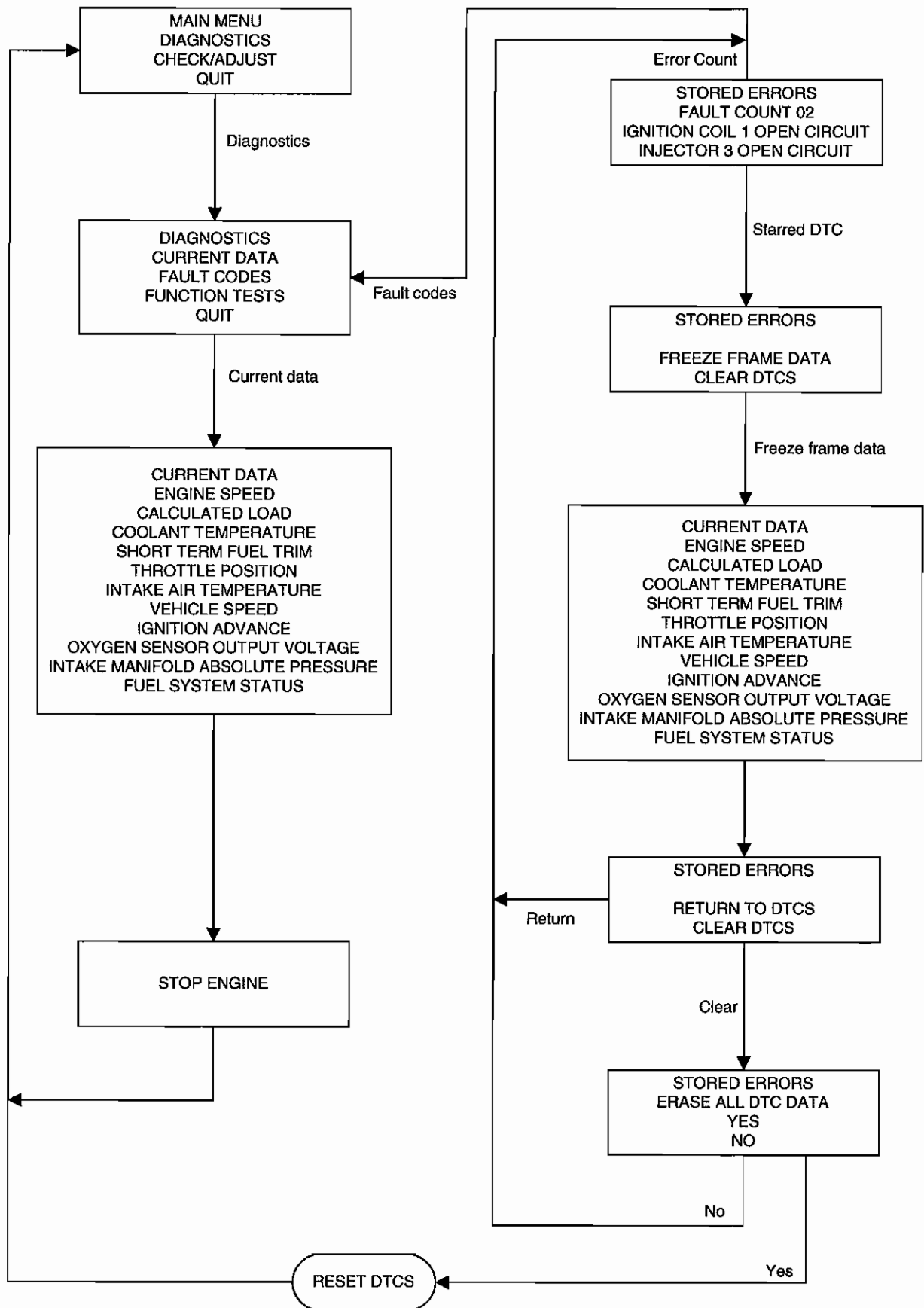

Fuel System/Engine Management

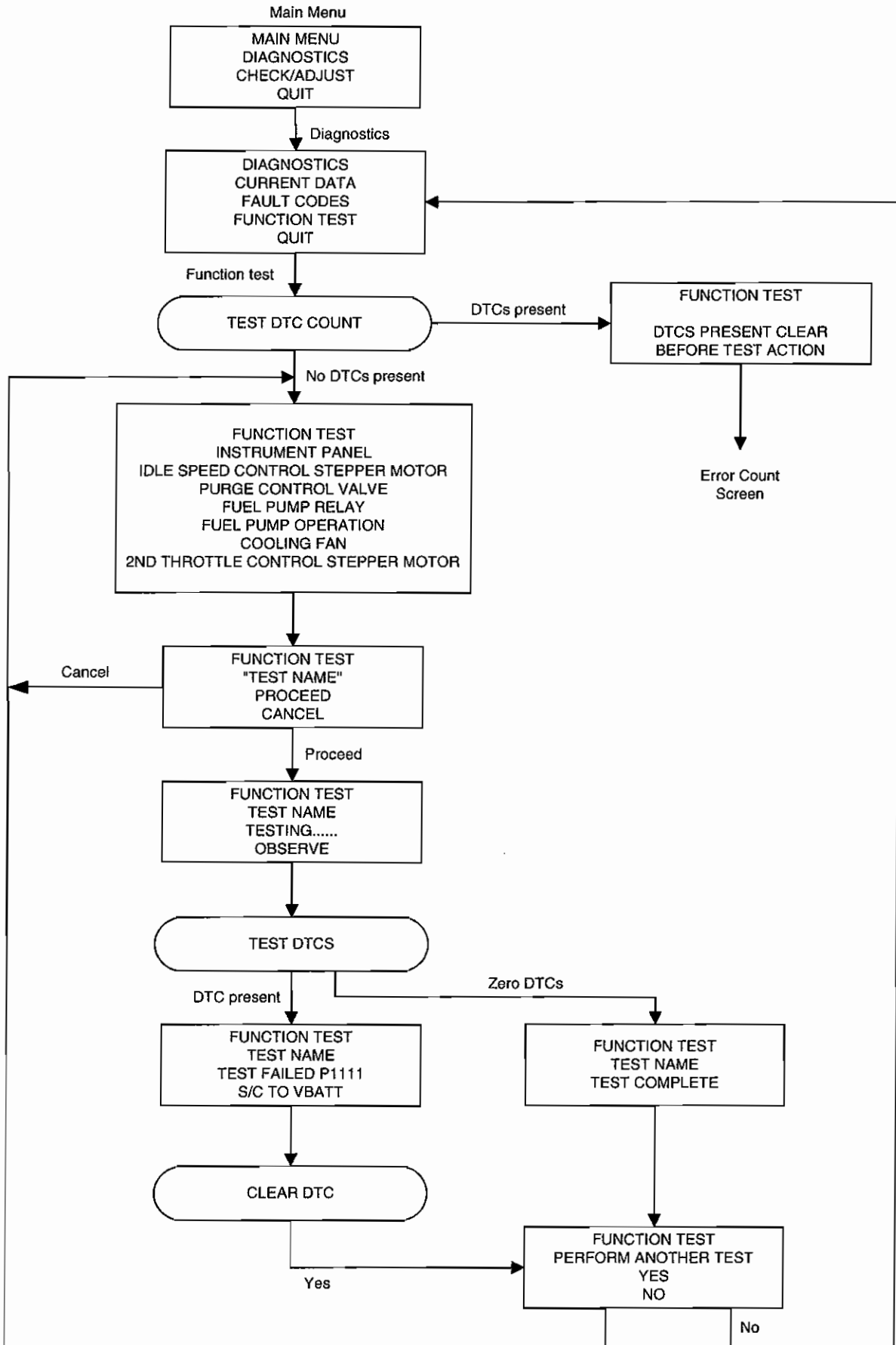

Fuel System/Engine Management

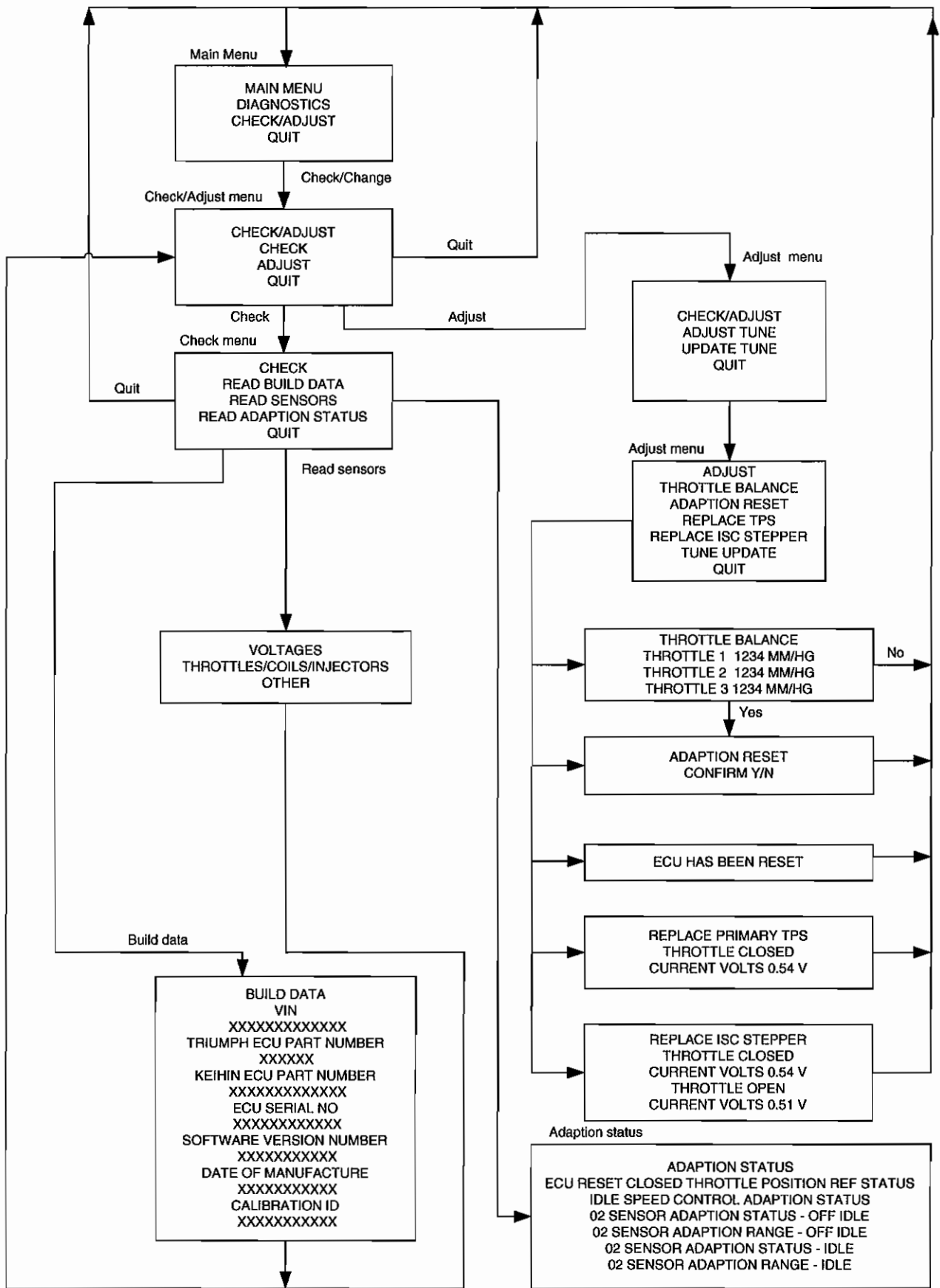

Fuel System/Engine Management

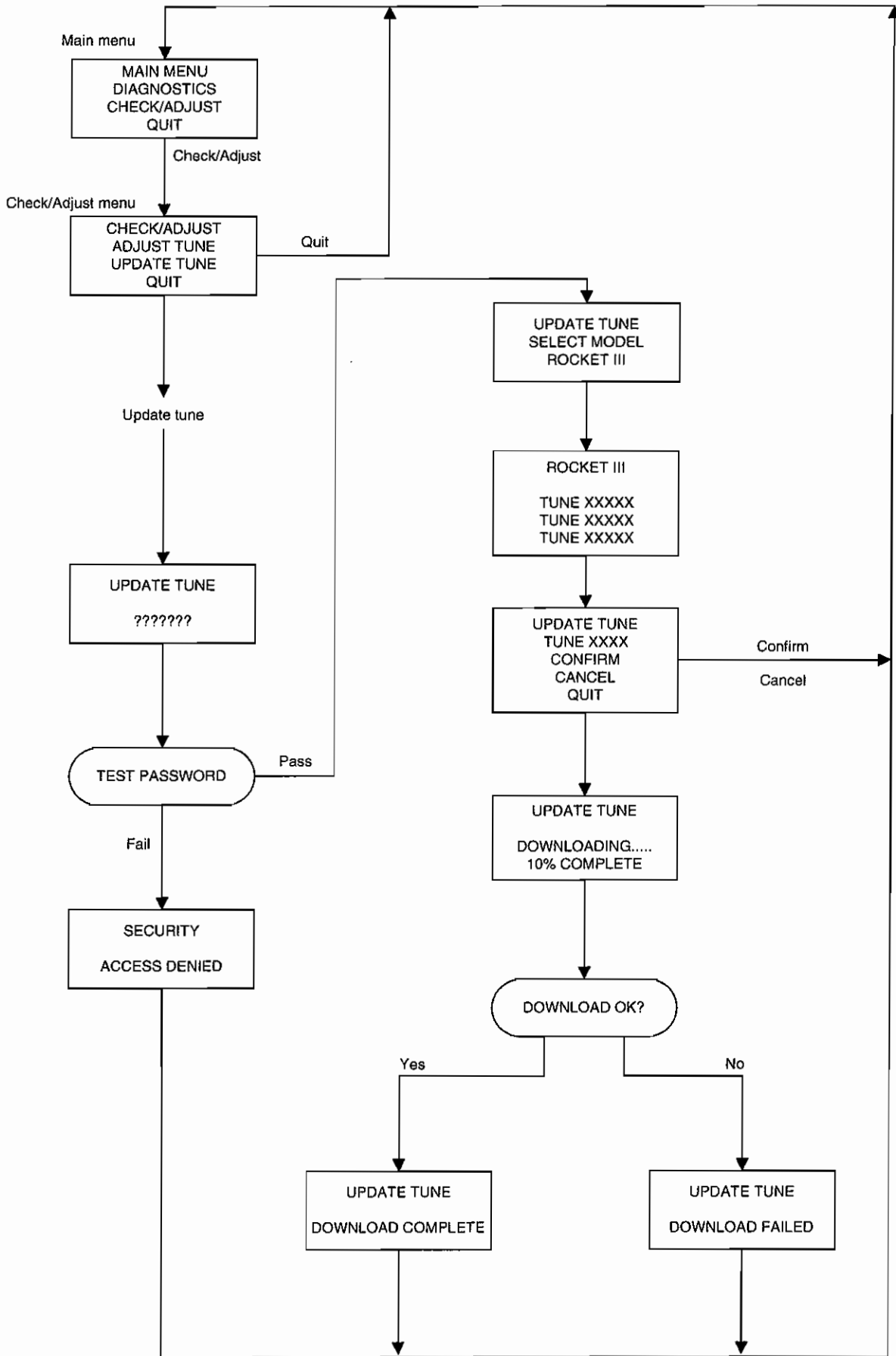

1. Connection and Power-Up

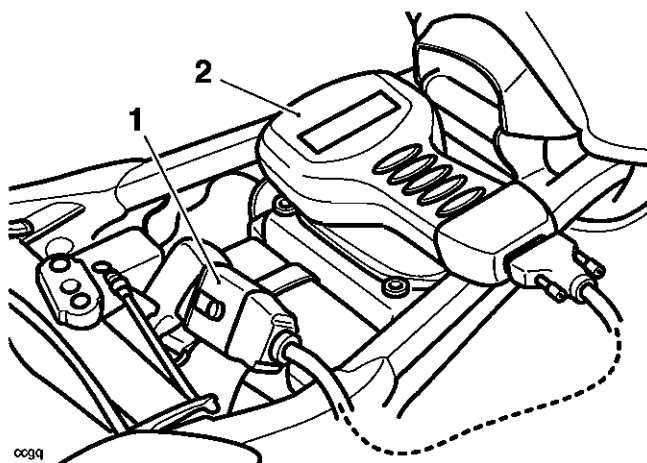

1. Tool

2. Connection to Main Harness

Connect the tool to the dedicated multiplug under the seat.

A message appears on the screen and certain checks are made automatically, e.g. Is the memory card fitted?

'SELECT LANGUAGE' will then be displayed.

2. SELECT LANGUAGE

| | | | | | | | | | | | | | | | | | | | | |
|---|--|--|--|---|---|---|---|---|---|--|---|---|---|---|---|---|---|---|---|---|
| | | | | S | E | L | E | C | T | | L | A | N | G | U | A | G | E | | |
| ▶ | | | | | | | | | | | E | N | G | L | I | S | H | | | |
| | | | | | | | | | | | F | R | A | N | C | A | I | S | | |
| | | | | | | | | | | | D | E | U | T | S | C | H | | | |
| | | | | | | | | | | | E | S | P | A | N | O | L | | | |
| | | | | | | | | | | | I | T | A | L | I | A | N | O | | |
| | | | | | | | | | | | N | E | D | E | R | L | A | N | D | S |

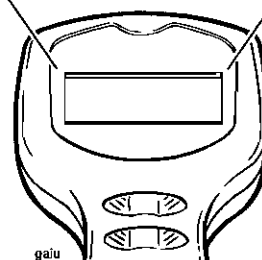

Use the 'Up' and 'Down' keys to move the cursor in column 1 and select the language required.

Note:

- The tool will always select English as the default language, and it is only necessary to use the cursor to select one of the other languages. The entire diagnostic session will then continue in the chosen language.

Press the validation key '*' to move on.

Fuel System/Engine Management

3. TRIUMPH MOTORCYCLES

| | | | | | | | | | | | | | | | | | |
|---|---|---|---|---|---|---|---|---|---|---|---|---|---|---|---|---|---|
| T | R | I | U | M | P | H | M | O | T | O | R | C | Y | C | L | E | S |
| | | | D | I | A | G | N | O | S | T | I | C | T | O | O | L | |
| S | O | F | T | W | A | R | E | V | E | R | S | I | O | N | | | |
| | | | 2 | 0 | 0 | 4 | - | 0 | 1 | | | | | | | | |

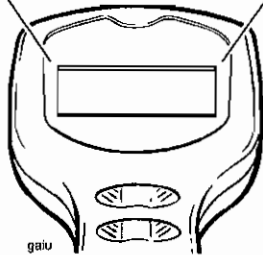

The screen will display the message 'Triumph Motorcycles Diagnostic Tool' and will also give the diagnostic software version and the software release year.

Press the validation key '*' to move on.

If the Return key (↵) is pressed, the tool will return to the '**SELECT LANGUAGE**' display.

4. SWITCH ON BIKE IGNITION

| | | | | | | | | | | | | | | | | | |
|--|--|--|---|---|---|---|---|---|---|---|---|---|---|---|--|--|--|
| | | | | | | | | | | | | | | | | | |
| | | | S | W | I | T | C | H | O | N | B | I | K | E | | | |
| | | | | | | I | G | N | I | T | I | O | N | | | | |
| | | | | | | | | | | | | | | | | | |

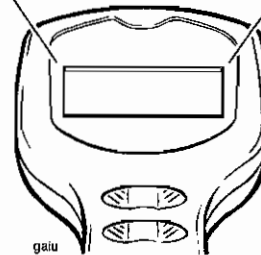

Switch on the ignition. Do NOT start the engine.

Press the validation key '*'. During a short delay period the tool will carry out certain validation checks.

If it detects a problem which will invalidate the test, '**DATA LINK FAULT RETRY?**' will be displayed.

If all is OK, '**SERVICE DATA**' will appear on the screen.

11. STOP ENGINE

| | | | | | | | | | | | | | | | | | | | |
|--|--|--|---|---|---|---|--|---|---|---|---|---|---|--|--|--|--|--|--|
| | | | | | | | | | | | | | | | | | | | |
| | | | S | T | O | P | | E | N | G | I | N | E | | | | | | |
| | | | | | | | | | | | | | | | | | | | |

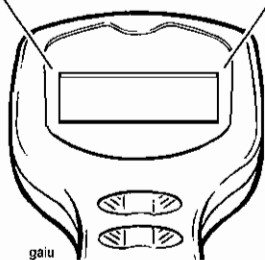

Switch off the engine.

As the tool is powered from the motorcycle, this will end the diagnostic session. To continue, return to the power-up section and select tests as required.

12. To select 'READ STORED DTCS' (Diagnostic Trouble Codes) from the MAIN MENU:

| | | | | | | | | | | | | | | | | | | | | | |
|---|--|--|--|---|---|---|---|---|---|---|---|---|---|---|---|---|--|---|---|---|---|
| | | | | | | | | | | | | | M | A | I | N | | M | E | N | U |
| ▶ | | | | D | I | A | G | N | O | S | T | I | C | S | | | | | | | |
| | | | | C | H | E | C | K | / | A | D | J | U | S | T | | | | | | |
| | | | | | | | | Q | U | I | T | | | | | | | | | | |

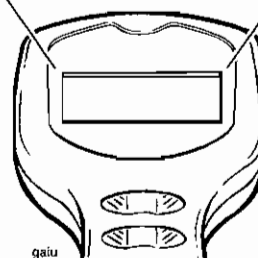

Use the 'Up' and 'Down' keys to position the cursor opposite **DIAGNOSTICS**.

Press the Validation key '*' to display **'DIAGNOSTICS'** menu.

Select **'READ STORED DTCS'**, and press the Validation key '*'.

'STORED DTCS' will be displayed.

17. STORED DTCS, ERASE ALL DTC DATA

| | | | | | | | | | | | | | | | | | | | | | | | | | | | |
|--|---|--|--|--|--|--|--|--|--|---|---|---|---|---|---|---|---|---|---|---|---|---|--|---|---|---|---|
| | | | | | | | | | | S | T | O | R | E | D | | D | T | C | S | | | | | | | |
| | | | | | | | | | | E | R | A | S | E | | A | L | L | | D | T | C | | D | A | T | A |
| | ▶ | | | | | | | | | Y | E | S | | | | | | | | | | | | | | | |
| | | | | | | | | | | N | O | | | | | | | | | | | | | | | | |

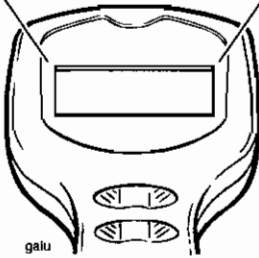

Scroll to position either 'YES' or 'NO' opposite the cursor.

If 'YES' is selected, press the Validation key '*' to erase all DTC data from the memory. 'MAIN MENU' will then be displayed.

Note:

- If you intend to examine the Function Tests, entry will be inhibited unless the DTC's have been erased.

If 'NO' is selected, press the Validation key '*' to return to operation 13.

That completes the DTC cycle.

18. To select 'FUNCTION TESTS' from the MAIN MENU:

| | | | | | | | | | | | | | | | | | | | | | | | | | | | | | | | |
|--|---|--|--|--|--|--|--|--|--|---|---|---|---|---|---|---|---|---|---|---|---|---|---|---|---|---|---|---|---|---|---|
| | | | | | | | | | | | | | | | | | | | | | D | I | A | G | N | O | S | T | I | C | S |
| | | | | | | | | | | C | U | R | R | E | N | T | | | | | D | A | T | A | | | | | | | |
| | ▶ | | | | | | | | | R | E | A | D | | S | T | O | R | E | D | | D | T | C | S | | | | | | |
| | | | | | | | | | | ▼ | | | | | | | | | | | | C | L | E | A | R | | | | | |

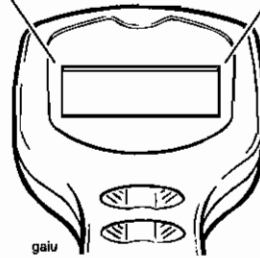

Use 'Up' and 'Down' keys to select 'DIAGNOSTICS' menu.

The following choices are available.

Press the Validation key '*'. 'DIAGNOSTICS' will be displayed.

Select 'FUNCTION TESTS', and press the Validation key '*'.

If no DTC'S are stored, 'FUNCTION TEST' will be displayed (see operation 20.).

If one or more DTC'S are stored, the message 'DTCS PRESENT CLEAR BEFORE TEST ACTION' will be displayed (see operation 19.).

Note:

- The diagnostic tool will not allow Function Tests to be accessed until all DTC's in the memory are removed.

Fuel System/Engine Management

19. FUNCTION TESTS

| | | | | | | | | | | | | | | | | | | |
|---|---|---|---|---|---|---|---|---|---|---|---|---|---|---|---|---|---|---|
| | | | | | | F | U | N | C | T | I | O | N | T | E | S | T | S |
| D | T | C | S | P | R | E | S | E | N | T | C | L | E | A | R | | | |
| B | E | F | O | R | E | T | E | S | T | A | C | T | I | O | N | | | |
| | | | | | | | | | | | | | | | | | | |

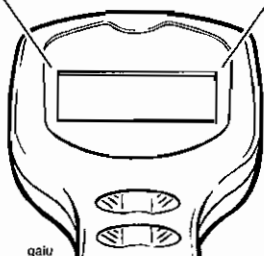

To clear the DTC's, press the Validation key '*'. 'STORED DTCS' will be displayed (see operation 13.).

Proceed as before via operations 14. to 17. Scroll to 'YES' and press the Validation key '*' to erase all DTC data; the **MAIN MENU** will be displayed again.

Note:

- The fault(s) which caused the DTC's to be set must be rectified and cleared before continuing the Function Tests.
- A full list of all the possible DTCs can be found earlier in this section.

Select 'DIAGNOSTICS' menu and 'FUNCTION TESTS' again pressing the Validation key '*' each time.

Because the DTC's have now been erased, 'FUNCTION TEST' (operation 20.) will now be displayed.

20. FUNCTION TEST

| | | | | | | | | | | | | | | | | | | |
|---|---|---|---|---|---|---|---|---|---|---|---|---|---|---|---|---|---|--|
| | | | | | | F | U | N | C | T | I | O | N | T | E | S | T | |
| | | | | | | | | | | | | | | | | | | |
| P | I | N | S | T | R | U | M | E | N | T | P | A | N | E | L | | | |
| ▼ | I | S | C | S | T | E | P | P | E | R | | | | | | | | |

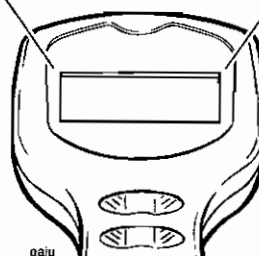

The following can be tested:

- Instrument panel.
- Idle speed control stepper.
- Purge valve.
- Fuel pump prime.
- Cooling fan operation.
- Fuel pump operation.
- Second throttle control stepper motor.

If the fault is electrical, this will then be reported as a DTC.

Instrument Panel test: A signal is sent which should cause the tachometer to read approximately 7,500 RPM, the water temperature gauge to show 100°C* and the speedometer 100 km/h*, all for 10 seconds.

Idle speed control stepper: A signal is sent which should cause the stepper to be driven to the fully closed position, then to the fully open position, pausing briefly in each position. DTCs are set if a malfunction is found.

* Or the imperial equivalents.

Purge valve (California models only): This test allows you to check operation of the valve. To detect valve operation, use a stethoscope to listen for valve operation. DTCs are set if a malfunction is found.

Fuel pump prime: This test provides you with the means to physically check the pump and relay operation. DTCs are set if a malfunction is found.

Cooling fan test: A signal is sent which should cause the fan to operate for a 10 second period. DTCs are set if a malfunction is found.

Fuel pump operation: This test provides you with the means to physically check the pump operation. DTCs are set if a malfunction is found. The pump is energised when the test is confirmed and ended when the Validation key '*' is pressed for a second time.

Second throttle stepper motor: A signal is sent which should cause the 2nd throttle stepper to be driven to the fully closed position, then to fully open. DTCs are set if a malfunction is found.

By pressing the Validation key '*', your selection will be noted and '**FUNCTION TEST**' (operation 21.) will be displayed.

Press the **Help** key (?) for more information.

Note:

- If the **Return** key (↵) is pressed, the tool will return to '**DIAGNOSTICS**' menu (operation 9.).

21. FUNCTION TEST

| | | | | | | | | | | | | | | | | |
|---|---|---|---|---|---|---|---|---|---|---|---|---|---|---|---|---|
| | | | | | F | U | N | C | T | I | O | N | T | E | S | T |
| | I | N | S | T | R | U | N | E | N | T | P | A | N | E | L | |
| ▶ | P | R | O | C | E | E | D | | | | | | | | | |
| | C | A | N | C | E | L | | | | | | | | | | |

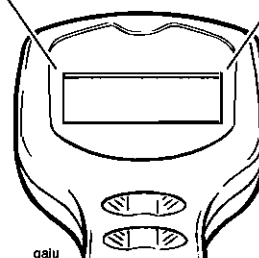

The function selected at operation 20. will now show on line 2. To show an example of this, we have chosen the '**INSTRUMENT PANEL**' test.

If you press the **Help** key (?), help relating to the specific test will be given. In this example, the screen will now read

- TACHOMETER - 7500 RPM
- TEMP GAUGE - not fitted, test will illuminate High Temp warning light.
- SPEEDOMETER - 100 km/h*

* Or the imperial equivalents.

If you wish to cancel that selection, scroll to '**CANCEL**' and press the Validation key '*'. The display will return to operation 20.

If you wish to test the component selected, scroll to '**PROCEED**' and press the Validation key '*'.

22. FUNCTION TEST

| | | | | | | | | | | | | | | | | |
|--|---|---|---|---|---|---|---|---|---|---|---|---|---|---|---|---|
| | | | | | F | U | N | C | T | I | O | N | T | E | S | T |
| | I | N | S | T | R | U | M | E | N | T | P | A | N | E | L | |
| | | T | E | S | T | I | N | G | . | | | | | | | |
| | | O | B | S | E | R | V | E | G | A | U | G | E | S | | |

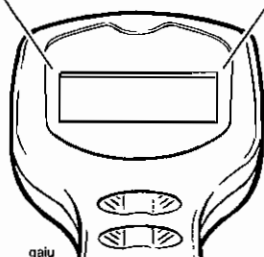

The screen now displayed will be specific to the component being tested:

In the example selected - **'INSTRUMENT PANEL'**, the instruction is to observe the gauges.

After a period of time, the screen will automatically change to either **'TEST COMPLETE'** (see operation 23.) which will indicate a satisfactory completion, or to **'TEST FAILED'** (see operation 25.) which will indicate failure.

23. FUNCTION TEST

| | | | | | | | | | | | | | | | | |
|--|---|---|---|---|---|---|---|---|---|---|---|---|---|---|---|---|
| | | | | | F | U | N | C | T | I | O | N | T | E | S | T |
| | I | N | S | T | R | U | M | E | N | T | P | A | N | E | L | |
| | | T | E | S | T | C | O | M | P | L | E | T | E | | | |
| | | | | | | | | | | | | | | | | |

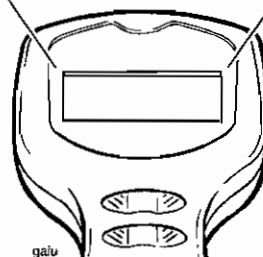

If the test is satisfactory the display will read **'TEST COMPLETE'**. Press the Validation key '*' to display **'FUNCTION TEST'** (operation 24.).

24. FUNCTION TEST

| | | | | | | | | | | | | | | | | | | |
|---|---|---|---|---|---|---|---|---|---|---|---|---|---|---|---|---|---|---|
| | | | | | | | F | U | N | C | T | I | O | N | T | E | S | T |
| P | E | R | F | O | R | M | A | N | O | T | H | E | R | T | E | S | T | |
| ▶ | Y | E | S | | | | | | | | | | | | | | | |
| | N | O | | | | | | | | | | | | | | | | |

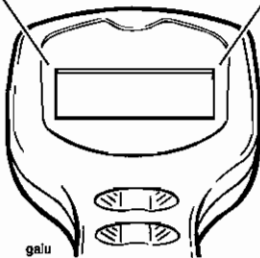

This display allows you to decide whether you wish to test another component.

Either - position the cursor on line 3 '**YES**' and press the Validation key '*' to return to the '**FUNCTION TEST**' selection menu,

or - position the cursor on line 4 '**NO**' and press the Validation key '*' to return to '**DIAGNOSTICS**' menu (operation 9.).

25. FUNCTION TEST

| | | | | | | | | | | | | | | | | | | |
|---|---|---|---|---|---|---|---|---|---|---|---|---|---|---|---|---|---|---|
| | | | | | | | F | U | N | C | T | I | O | N | T | E | S | T |
| I | N | S | T | R | U | M | E | N | T | P | A | N | E | L | | | | |
| T | E | S | T | F | A | I | L | E | D | P | 1 | 1 | 1 | 7 | | | | |
| | | | | | | | | | | | | | | | | | | |

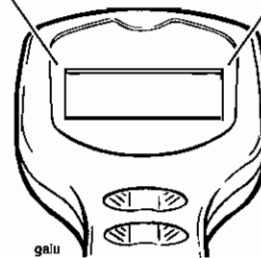

If the test selected at operation 22. is unsatisfactory, a DTC will be displayed on line 3 of this display.

Press the Help key (?) to access the diagnosis information associated with that code.

Press the Validation key '*' if you wish to test another component (operation 24.).

Note:

- Any DTC's logged in the system will be automatically cleared at this point.

To return to the '**DIAGNOSTICS**' menu, Select '**QUIT**' and press the Validation key '*' to return to the '**MAIN MENU**' (operation 8.).

That completes the **FUNCTION TESTS** cycle.

Fuel System/Engine Management

26. To select 'CHECKS/ADJUSTMENTS' from the MAIN MENU (operation 8.):

| | | | | | | | | | | | | | | | | | | |
|---|--|--|--|--|--|---|---|---|---|---|---|---|---|---|---|---|---|---|
| | | | | | | | | | | M | A | I | N | | M | E | N | U |
| | | | | | | | | | | | | | | | | | | |
| | | | | | | D | I | A | G | N | O | S | T | I | C | S | | |
| ▶ | | | | | | C | H | E | C | K | / | A | D | J | U | S | T | |
| | | | | | | | | | | | | | | | | | | |
| | | | | | | | | | | | | | | | | | | |
| | | | | | | | | | | | | | | | | | | |
| | | | | | | | | | | | | | | | | | | |
| | | | | | | | | | | | | | | | | | | |
| | | | | | | | | | | | | | | | | | | |

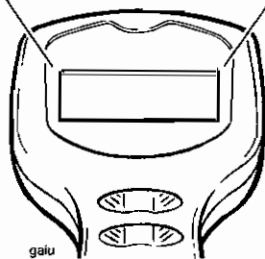

Use the 'Up' and 'Down' keys to position the cursor opposite '**CHECK/ADJUST**'.

Press the Validation key '*'; the '**CHECK/ADJUST**' menu will be displayed.

27. CHECK/ADJUST

| | | | | | | | | | | | | | | | | | | | | | | |
|---|--|--|--|--|--|--|--|--|--|--|---|---|---|---|---|---|---|---|---|---|---|---|
| | | | | | | | | | | | C | H | E | C | K | / | A | D | J | U | S | T |
| ▶ | | | | | | | | | | | C | H | E | C | K | | | | | | | |
| | | | | | | | | | | | | | | | | | | | | | | |
| | | | | | | | | | | | | | | | | | | | | | | |
| | | | | | | | | | | | | | | | | | | | | | | |
| | | | | | | | | | | | | | | | | | | | | | | |
| | | | | | | | | | | | | | | | | | | | | | | |
| | | | | | | | | | | | | | | | | | | | | | | |
| | | | | | | | | | | | | | | | | | | | | | | |
| | | | | | | | | | | | | | | | | | | | | | | |
| | | | | | | | | | | | | | | | | | | | | | | |

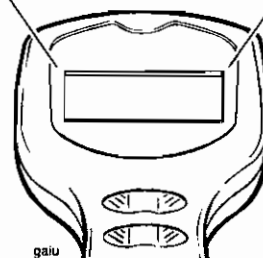

Use the 'Up' and 'Down' keys to position the cursor as follows, and then press the Validation key '*':

Opposite '**CHECK**' - '**CHECKS**' will be displayed (operation 28.).

Opposite '**ADJUST**' - '**ADJUST**' will be displayed (operation 32.).

Opposite '**QUIT**' - to return to '**MAIN MENU**' (operation 8.).

Fuel System/Engine Management

30. SENSOR DATA

| | | | | | | | | | | | | | | | | | | |
|---|---|---|---|---|---|---|---|---|---|---|---|---|---|---|---|---|---|---|
| | | | | | | | | S | E | N | S | O | R | D | A | T | A | |
| | | | | | | | | | | | | | | | | | | |
| P | A | I | R | S | E | N | S | O | R | | | | | | | S | V | |
| ▼ | A | I | R | T | E | M | P | | | | | | | | | I | S | C |

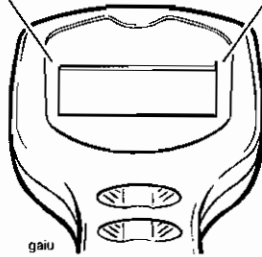

The display can be scrolled to show:

The status of the various sensors and actuators

To obtain further data information, scroll the appropriate line to the help key mark (?) and press the Help key.

Note:

- **The help information shows the likely range of readings for a correctly functioning system at normal operating temperature.**

That completes examination of the Checks.

Press the Validation key '*' to return to '**CHECK/ADJUST**' (operation 27.).

31. ADAPTION STATUS

| | | | | | | | | | | | | | | | | | | | | | |
|--|--|--|--|--|--|--|--|---|---|---|---|---|---|---|---|---|---|---|---|---|---|
| | | | | | | | | A | D | A | P | T | I | O | N | S | T | A | T | U | S |
| | | | | | | | | | | | | | | | | | | | | | |
| | | | | | | | | E | N | G | I | N | E | T | E | M | P | O | U | T | |
| | | | | | | | | O | F | R | A | N | G | E | | | | | | | |
| | | | | | | | | P | L | E | A | S | E | U | R | I | T | | | | |

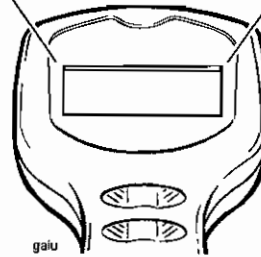

Because adaption only takes place at normal operating temperature, the above screen will be displayed until the engine reaches normal operating temperature.

Until the engine warms or cools to the correct temperature range, the tool will not allow access to any other functions. If you wish to escape from this area (and not carry out the adjustment) switch off the ignition and disconnect the tool.

Once the correct temperature range has been reached, the **ADAPTION STATUS** screen (operation 32.) will automatically be displayed.

Fuel System/Engine Management

| | | | | | | | | | | | | | | | | | | | | | | | | | | | | | |
|---|---|---|---|---|---|--|---|---|---|---|---|---|---|---|--|--|--|---|---|---|---|---|---|--|--|--|---|---|---|
| | | | | | | | A | D | A | P | T | I | O | N | | | | D | A | T | A | | | | | | | | |
| C | L | O | S | E | D | | T | H | R | O | T | T | L | E | | | | | | N | O | | | | | | | | |
| I | S | C | | | | | A | D | A | P | T | I | O | N | | | | | | 7 | 5 | % | | | | | | | |
| O | 2 | | | | | | S | E | N | S | O | R | | | | | | | | A | D | A | P | | | | 5 | 1 | % |

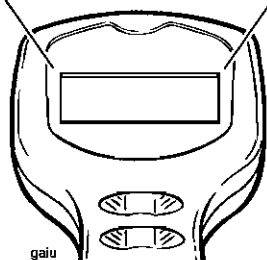

The display can be scrolled to show:

The adaption status of the various sensors and actuators involved in the adaption process will give an indication as to whether or not the vehicle is correctly adapted. If the readings show an incorrect adaption status, refer to the table of contents for the location of further information and the actions necessary to force correct adaption.

See page 8-110 for additional information on forcing adaption.

The data displayed under this option are:

| Function Examined | Report Method |
|---|---------------------|
| Closed throttle position reference status | adapted/not adapted |
| Idle speed control adaption status | % |
| Oxygen sensor adaption status (off idle) | % |
| Oxygen sensor adaption range (off idle) | % |
| Oxygen sensor adaption status (idle) | % |
| Oxygen sensor adaption range (idle) | % |

Note:

- Several forced adaptations may be needed to fully adapt an individual motorcycle.

32. ADJUST

| | | | | | | | | | | | | | | | |
|---|--|--|---|---|---|---|---|---|---|---|---|---|---|--|--|
| | | | | | | | | A | D | J | U | S | T | | |
| ▶ | | | A | D | J | U | S | T | | T | U | N | E | | |
| | | | U | P | D | A | T | E | | T | U | N | E | | |
| | | | | | Q | U | I | T | | | | | | | |

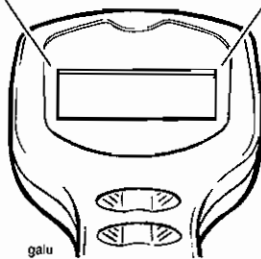

Position the cursor on line 2 '**ADJUST TUNE**' if you wish to check and/or adjust the values of certain tune items. Then press the Validation key '*' to display **ADJUST TUNE** (see operation 33.).

In special circumstances, Triumph will request you to introduce a completely new engine tune. Given this situation, select '**UPDATE TUNE**' and press the Validation key '*' (see operation 36.).

33. ADJUST TUNE

| | | | | | | | | | | | | | | | | | | | |
|--|---|---|---|---|---|---|---|---|---|---|---|---|---|---|---|---|---|---|---|
| | | | | | | | A | D | J | U | S | T | T | U | N | E | | | |
| | | R | E | S | E | T | | A | D | A | P | T | I | O | N | S | | | |
| | | B | A | L | A | N | C | E | | T | H | R | O | T | T | L | E | S | |
| | ▶ | T | H | R | O | T | T | L | E | | P | O | T | | R | E | N | E | W |
| | | I | S | C | | S | T | E | P | P | E | R | | R | E | N | E | W | |

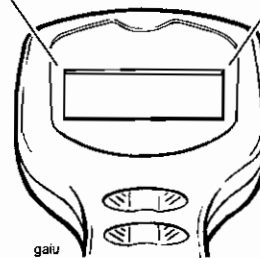

The following allow adjustments to be made to items which affect the engine operation

Position the cursor opposite the setting you wish to adjust and press the Validation key '*'.

RESET ADAPTIONS. - See operation 34.

BALANCE THROTTLES. - See operation 35.

THROTTLE POT RENEW. - See page 8-102 for details on when and how to use this function.

IDLE SPEED CONTROL STEPPER RENEW - See page 8-106 for details on when and how to use this function.

34. ADJUST TUNE (adaption reset)

| | | | | | | | | | | | | | | | | | | | | | | |
|---|--|--|--|--|--|--|--|---|---|---|---|---|---|---|---|---|---|---|---|---|--|--|
| | | | | | | | | A | D | A | P | T | I | O | N | R | E | S | E | T | | |
| | | | | | | | | | | | | | | | | | | | | | | |
| | | | | | | | | C | O | N | F | I | R | M | | | | | | | | |
| ▶ | | | | | | | | Y | E | S | | | | | | | | | | | | |
| | | | | | | | | N | O | | | | | | | | | | | | | |

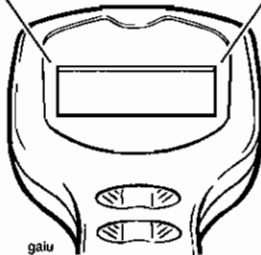

After selecting the adaption reset option, confirm or reject the option by positioning the cursor opposite the option chosen and press the Validation key '*'.
 If YES is chosen, a screen will confirm that adaptations have been reset.

If NO is chosen, you will be returned to the adjust tune menu.

If NO is chosen, you will be returned to the adjust tune menu.

Note:

- Resetting the adaption values does not adapt the motorcycle. This can only be done by the method explained later in this section. Adaption reset only returns adaption values to their 'start' point.

35. BALANCE THROTTLES

| | | | | | | | | | | | | | | | | | | | | | | |
|--|--|--|--|--|--|--|--|--|--|--|--|--|--|--|--|--|--|--|--|--|--|--|
| | | | | | | | | | | | | | | | | | | | | | | |
| | | | | | | | | | | | | | | | | | | | | | | |
| | | | | | | | | | | | | | | | | | | | | | | |
| | | | | | | | | | | | | | | | | | | | | | | |
| | | | | | | | | | | | | | | | | | | | | | | |

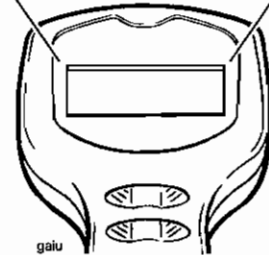

Using the **BALANCE THROTTLES** command, the throttles may be balanced without the need to connect an external device to measure the vacuum levels in each throttle body. The diagnostic tool displays data taken from the manifold absolute pressure sensor reading for each throttle.

Once throttle imbalance has been reduced to a pre-determined level, the top line of information will display the word ***BALANCED***. Under any other conditions where imbalance is detected, nothing will be displayed indicating that the throttles require balancing.

38. UPDATE TUNE

| | | | | | | | | | | | | | | | | | | | | | |
|---|---|---|---|---|---|---|--|--|--|--|--|---|---|---|---|---|---|---|---|---|---|
| | | | | | | | | | | | | U | P | D | A | T | E | T | U | N | E |
| | S | E | L | E | C | T | | | | | | M | O | D | E | L | | | | | |
| ▶ | R | O | C | K | E | T | | | | | | | | | | | | | | | |
| | | | | | | | | | | | | | | | | | | | | | |

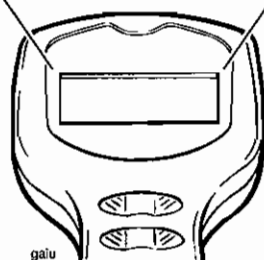

Align the cursor with the model to which a tune is to be downloaded and, when satisfied that the selection is correct, press the validation key '*'.

Once a model has been selected and the validation key pressed, screen 38. will be displayed.

39. UPDATE TUNE

| | | | | | | | | | | | | | | | | | | | | | | | | | | | | | |
|--|--|--|--|--|--|--|--|--|--|--|--|--|--|--|--|--|--|--|---|---|---|---|---|---|---|---|---|---|---|
| | | | | | | | | | | | | | | | | | | | R | O | C | K | E | T | 3 | | | | |
| | | | | | | | | | | | | | | | | | | | | T | U | N | E | | 2 | X | X | X | X |
| | | | | | | | | | | | | | | | | | | | | T | U | N | E | | 2 | X | X | X | X |
| | | | | | | | | | | | | | | | | | | | | T | U | N | E | | 2 | X | X | X | X |

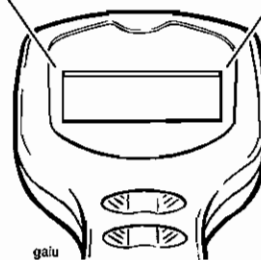

Scroll to the tune required and press the Validation key '*' to move on to operation 39.

Press the help key for information on the applicability of each tune number.

Fuel System/Engine Management

40. UPDATE TUNE

| | | | | | | | | | | | | | | | | | | |
|---|---|---|---|---|---|---|---|---|---|---|---|---|---|---|---|---|---|---|
| | | | | | | | | | U | P | D | A | T | E | T | U | N | E |
| | T | U | N | E | 2 | X | X | X | X | | | | | | | | | |
| ▶ | | | | | C | O | N | F | I | R | M | | | | | | | |
| ▼ | | | | | C | A | N | C | E | L | | | | | | | | |

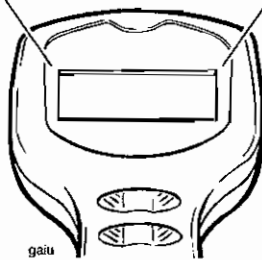

Scroll to either **'CONFIRM'**, **'CANCEL'** or **'QUIT'** (quit option will not be visible until the text has been scrolled) then press the Validation key '*'.

If **'QUIT'** has been selected - this will return to **MAIN MENU** (operation 8.)

If **'CANCEL'** has been selected - return to operation 38.

If **'CONFIRM'** has been selected, downloading will begin.

41. UPDATE TUNE (confirm selected)

| | | | | | | | | | | | | | | | | | | | | | | | | | | | | | | |
|--|--|--|--|--|---|---|---|---|---|---|---|---|---|---|---|---|---|---|---|---|---|---|---|---|---|---|---|---|--|--|
| | | | | | | | | | | | | | | | | | | | U | P | D | A | T | E | T | U | N | E | | |
| | | | | | D | O | W | N | L | O | A | D | I | N | G | . | . | . | . | . | . | | | | | | | | | |
| | | | | | 1 | 0 | % | C | O | M | P | L | E | T | E | | | | | | | | | | | | | | | |
| | | | | | | | | | | | | | | | | | | | | | | | | | | | | | | |

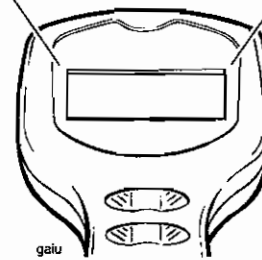

The screen will show **'DOWNLOADING'**, and the selected software will be automatically downloaded into the ECM.

When complete, the screen will display **'DOWNLOAD COMPLETE'**.

Press the Validation key '*' to return to the **'MAIN MENU'** (operation 8.).

If downloading has been unsuccessful the screen will display **'DOWNLOAD FAILED'**. Should this message appear, refer to 41., restarting tune download.

Press the Validation key '*' to return to the **'MAIN MENU'** (operation 8.).

Note:

- **A TUNE DOWNLOAD CAN TAKE UP TO 15 MINUTES TO COMPLETE.**

42. RESTARTING TUNE DOWNLOAD

Caution

If, for any reason downloading is interrupted, the ECM will not function and tune download cannot be restarted in the normal way. This is because the tool's operating system has been erased from the ECM's memory and has not yet been fully replaced.

Download interruption can occur for a variety of reasons such as, accidental disconnection of the tool, a flat battery, turning the ignition switch to OFF during download etc.

In these circumstances, a special-tool key-press-sequence must be followed which is described below

To restart download, switch the motorcycle ignition to OFF and disconnect the tool. Reconnect the tool, switch the motorcycle ignition to ON, and scroll through to the screen shown below.

| | | | | | | | | | | | | | | | | | | |
|---|---|---|---|---|---|---|---|---|---|---|---|---|---|---|---|---|---|---|
| T | R | I | U | M | P | H | | N | O | T | O | R | C | Y | C | L | E | S |
| | | | D | I | A | G | N | O | S | T | I | C | | T | O | O | L | |
| S | O | F | T | W | A | R | E | | V | E | R | S | I | O | N | | | |
| | | | | | 2 | 0 | 0 | 4 | - | 0 | 1 | | | | | | | |

From this screen, use the following button press sequence:

HELP (?) - HELP (?) - RETURN (↵) - HELP (?) VALIDATE (*).

The dealer log-in screen will then be displayed. From that screen, download can be restarted in the normal way.

Note:

- **The software version number is not relevant to this procedure. All versions of the diagnostic software will operate in the way described.**

Fuel System/Engine Management

Electrical Connectors

Before beginning any diagnosis, the following connector related information should be noted:

Note:

- A major cause of hidden electrical faults can be traced to faulty electrical connectors. For example:
- Dirty/corroded terminals.
- Damp terminals.
- Broken or bent cable pins within multi-plugs.

For example, the electronic control module (ECM) relies on the supply of accurate information to enable it to plan the correct fuelling and ignition timing. One dirty terminal will cause an excessive voltage drop resulting in an incorrect signal to the ECM.

If, when carrying out fault diagnosis, a fault appears to clear by simply disconnecting and reconnecting an electrical plug, examine each disconnected plug for the following.

Before Disconnection:

- If testing with a voltmeter, the voltage across a connector should be virtually battery volts (unless a resistor is fitted in the circuit). If there is a noticeable change, suspect faulty/dirty connections.

When Disconnecting a Connector:

- Check for a security device that must be released before the connector can be separated. E.G. barb, hook and eye etc.

When Inspecting a Connector:

- Check that the individual pins have not been bent.
- Check for dampness/dirt/corrosion.
- Check cables for security.
- Check cable pin joints for damage.

When Connecting a Connector.

- Ensure there is no dirt around the connector/seal.
- Push together squarely to ensure terminals are not bent or incorrectly located.
- Push the two halves together positively.

Disconnection of ECM connectors

Note:

- Two different sized connectors are used in the ECM, which ensures correct connection is always made.

! Caution

When disconnecting a connector, never pull directly on the wires as this may result in cable and connector damage.

! Caution

Never disconnect an ECM when the ignition switch is in the ON position as this may cause multiple fault codes to be logged in the ECM memory.

Always disconnect an ECM after disconnecting the battery negative (black) lead first.

1. Press down on the locking device and gently pull back on the connector to release it from the ECM.

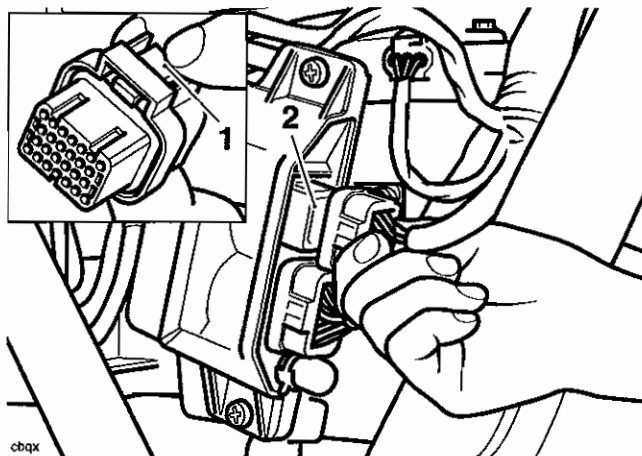

cbqx

1. Locking device (inset)
2. Socket

Reconnection of ECM connectors

Caution

Damage to the connector pins may result if an attempt to fit the connectors incorrectly is made.

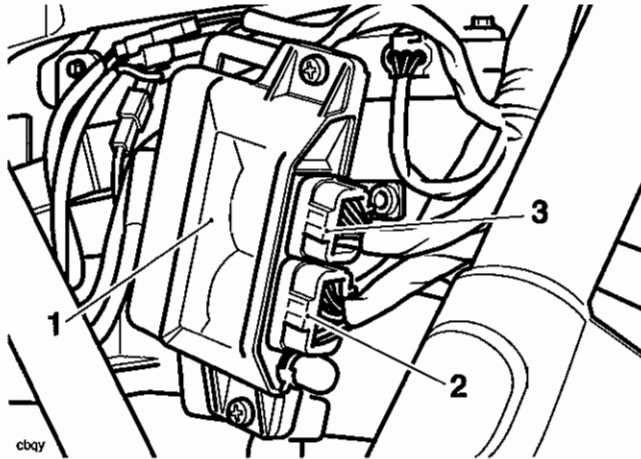

1. ECM

2. Large connector

3. Small connector

2. Fit the connector into its socket and, whilst holding the connector in place, insert it fully into the ECM until the locking device retains it.

Further Diagnosis

The tables that follow will, if used correctly, help to pinpoint a fault in the system once a diagnostic trouble code has been stored.

Fuel System/Engine Management

Crankshaft Sensor

| Fault Code | Possible cause | Action |
|------------|--------------------------------|--|
| P0335 | Crankshaft sensor system fault | View & note diagnostic tool 'freeze frame' data if available. Ensure sensor is fitted correctly and connector is secure. Disconnect ECM and proceed to pinpoint test 1 |

Pinpoint Tests

| Test | Result | Action |
|---|---------------------|--|
| 1 Check terminal and cable integrity: - ECM pin A13 - ECM pin A14 | OK | Disconnect sensor and proceed to test 2 |
| | Faulty | Rectify fault, proceed to test 6 |
| 2 Check cable for short circuit: - ECM pin A13 to earth - ECM pin A14 to earth | OK | Proceed to test 3 |
| | Short circuit | Locate and rectify wiring fault, proceed to test 6 |
| 3 Check cable continuity: - ECM pin A14 to sensor pin 1 - ECM pin A13 to sensor pin 2 | OK | Proceed to test 4 |
| | Open circuit | Locate and rectify wiring fault, proceed to test 6 |
| 4 Check cable for short circuit: - ECM pin A13 to ECM pin A14 | OK | Renew crankshaft sensor, proceed to test 6 |
| | Short circuit | Locate and rectify wiring fault, proceed to test 6 |
| 5 Check crank toothed wheel: - Damage to teeth - magnetic debris contamination | OK | Proceed to test 6 |
| | Faulty | Clean / renew toothed wheel, proceed to test 6 |
| 6 Reconnect harness, clear fault code and run engine to verify fault cleared | OK | Action complete - quit test |
| | Fault still present | Contact Triumph service |

Circuit Diagram

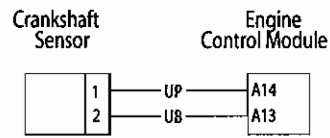

Fuel System/Engine Management

Idle Speed Control

| Fault Code | Possible cause | Action |
|------------|----------------------------------|--|
| P0505 | ISC stepper motor / wiring fault | View & note diagnostic tool 'freeze frame' data if available. View & note diagnostic tool 'sensor' data. Ensure sensor connector is secure. Disconnect ECM and proceed to pinpoint test 1 |

Pinpoint Tests

| Test | Result | Action |
|---|---------------|--|
| 1 Check cable and terminal integrity: - ECM pin B23 - ECM pin B07 - ECM pin B11 - ECM pin B03 | OK | Proceed to test 2 |
| | Faulty | Rectify fault, proceed to test 7 |
| 2 Check resistance value: - ECM pin B23 to ECM pin B07 - ECM pin B11 to ECM pin B03 | 4Ω to 12Ω | Disconnect stepper motor and proceed to test 3 |
| | Open circuit | Proceed to test 4 |
| | Short circuit | Disconnect stepper motor and proceed to test 5 |
| 3 Check cable for short circuit: - ECM pin B23 to earth - ECM pin B07 to earth - ECM pin B11 to earth - ECM pin B03 to earth | OK | Proceed to test 7 |
| | Short circuit | Locate and rectify wiring fault, proceed to test 7 |
| 4 Check cable continuity: - ECM pin B23 to stepper motor pin A - ECM pin B07 to stepper motor pin A1 - ECM pin B11 to stepper motor pin B - ECM pin B03 to stepper motor pin B1 | OK | Proceed to test 6 |
| | Open circuit | Locate and rectify wiring fault, proceed to test 7 |
| 5 Check cable for short circuit: - ECM pin B23 to ECM pin B07 - ECM pin B11 to ECM pin B03 | OK | Proceed to test 6 |
| | Short circuit | Locate and rectify wiring fault, proceed to test 7 |
| 6 Check stepper motor resistance: - Motor pin A to motor pin A1 - Motor pin B to motor pin B1 | 4Ω to 12Ω | Proceed to test 7 |
| | Faulty | Renew stepper motor, proceed to test 7 |
| 7 Reconnect harness, clear fault code and run diagnostic tool function test to visually verify operation of stepper motor | OK | Action complete - quit test |
| | Fault | Contact Triumph service |

Circuit Diagram

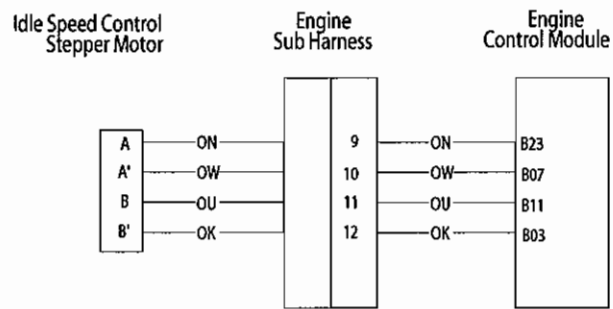

Fuel System/Engine Management

Fuel Injectors

| Fault Code | Possible cause | Action |
|-------------|---|--|
| P0201/02/03 | Injection system fault - Injector 1/2/3 - Misfire indicates open circuit - Flooding indicates short circuit | View & note diagnostic tool 'freeze frame' data if available. Ensure relevant injector connector is secure. Disconnect ECM and proceed to pinpoint test 1 |

Pinpoint Tests

| Test | Result | Action |
|--|---------------------|--|
| 1 Check cable and terminal integrity: - ECM pin B05 - ECM pin B06 - ECM pin B17 | OK | Proceed to test 2 |
| | Faulty | Rectify fault, proceed to test 7 |
| 2 Check resistance value: - ECM pin A20 to ECM pin B05 (injector 1) - ECM pin A20 to ECM pin B06 (injector 2) - ECM pin A20 to ECM pin B17 (injector 3) | 12.5Ω to 14.0Ω | Proceed to test 3 |
| | Open circuit | Disconnect relevant injector and proceed to test 4 |
| | Short circuit | Disconnect relevant injector and proceed to test 5 |
| 3 Check cable for short circuit to ground: - ECM pin B05 to earth - ECM pin B06 to earth - ECM pin B17 to earth | OK | Proceed to test 7 |
| | Short circuit | Locate and rectify wiring fault, proceed to test 7 |
| 4 Check cable continuity: - ECM pin A20 to relevant injector pin 2 - ECM pin B05 to injector 1 pin 1 - ECM pin B06 to injector 2 pin 1 - ECM pin B17 to injector 3 pin 1 | OK | Proceed to test 6 |
| | Open circuit | Locate and rectify wiring fault, proceed to test 7 |
| 5 Check cable for short circuit to supply box: - ECM pin A20 to ECM pin B05 (inj 1) - ECM pin A20 to ECM pin B06 (inj 2) - ECM pin A20 to ECM pin B17 (inj 3) | OK | Proceed to test 6 |
| | Short circuit | Locate and rectify wiring fault, proceed to test 7 |
| 6 Check relevant injector resistance: - Injector pin 1 to injector pin 2 | 12.5Ω to 14.0Ω | Proceed to test 7 |
| | Faulty | Renew relevant injector, proceed to test 7 |
| 7 Reconnect harness, clear fault code and run engine to verify fault cleared | OK | Action complete - quit test |
| | Fault still present | Contact Triumph service |

Circuit Diagram

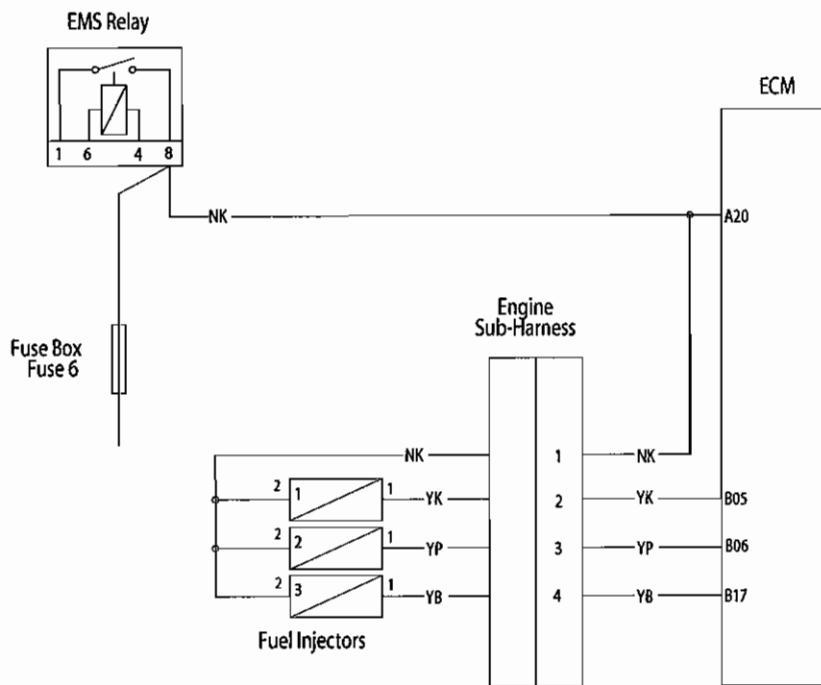

Fuel System/Engine Management

Throttle Position Sensor

| Fault Code | Possible cause | Action |
|----------------|--|--|
| P0122 P0123 | Throttle position sensor low input voltage (short to ground or open circuit) Throttle position sensor high input voltage (short circuit to sensor supply) | View & note diagnostic tool 'freeze frame' data if available. View & note diagnostic tool 'sensor' data. Ensure sensor connector is secure. Disconnect ECM and proceed to pinpoint test 1 |

Pinpoint Tests

| Test | Result | Action |
|--|---------------------|--|
| 1 Check cable and terminal integrity: - ECM pin A01 - ECM pin A07 - ECM pin A10 | OK | Disconnect sensor and proceed to test 2 |
| | Faulty | Rectify fault, proceed to test 5 |
| 2 Check cable for short circuit: - ECM pin A10 to ground | OK | Proceed to test 3 |
| | Short circuit | Locate and rectify wiring fault, proceed to test 5 |
| 3 Check cable continuity: - ECM pin A01 to sensor pin 1 - ECM pin A07 to sensor pin 2 - ECM pin A10 to sensor pin 3 | OK | Proceed to test 4 |
| | Open circuit | Locate and rectify wiring fault, proceed to test 5 |
| 4 Check cable for short circuit: - ECM pin A10 to ECM pin A01 - ECM pin A10 to ECM pin A07 | OK | Renew throttle position sensor, proceed to test 5 |
| | Short circuit | Locate and rectify wiring fault, proceed to test 5 |
| 5 Reconnect harness, clear fault code and run engine to verify fault cleared | OK | Action complete - quit test |
| | Fault still present | Contact Triumph service |

Circuit Diagram

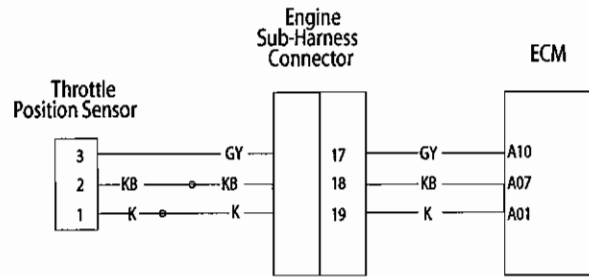

Fuel System/Engine Management

Purge Valve

| Fault Code | Possible cause | Action |
|------------|--|---|
| P0444 | Open circuit or short circuit to earth | View & note diagnostic tool 'sensor' data. Ensure purge valve connector is secure. Disconnect ECM and proceed to pinpoint test 1 |
| P0445 | Short circuit to battery+ | Disconnect purge valve and proceed to pinpoint test 5 |

Pinpoint Tests

| Test | Result | Action |
|---|---------------|--|
| 1 Check cable and terminal integrity: - ECM pin B31 | OK | Proceed to test 2 |
| | Faulty | Rectify fault, proceed to test 7 |
| 2 Check resistance value: - ECM pin A20 to ECM pin B31 | 24Ω to 28Ω | Disconnect purge valve and proceed to test 3 |
| | Open circuit | Proceed to test 4 |
| | Short circuit | Disconnect purge valve and proceed to test 5 |
| 3 Check cable for short circuit: - ECM pin B31 to earth | OK | Proceed to test 7 |
| | Short circuit | Locate and rectify wiring fault, proceed to test 7 |
| 4 Check cable continuity: - ECM pin B31 to valve pin 2 - ECM pin A20 to valve pin 1 | OK | Proceed to test 6 |
| | Open circuit | Locate and rectify wiring fault, proceed to test 7 |
| 5 Check cable for short circuit: - ECM pin A20 to ECM pin B31 | OK | Proceed to test 6 |
| | Short circuit | Locate and rectify wiring fault, proceed to test 7 |
| 6 Check purge valve resistance: - Valve pin 1 to valve pin 2 | 24Ω to 28Ω | Proceed to test 7 |
| | Faulty | Renew purge valve, proceed to test 7 |
| 7 Reconnect harness, clear fault code and run diagnostic tool function test to visually verify operation of purge valve | OK | Action complete - quit test |
| | Fault | Contact Triumph service |

Circuit Diagram

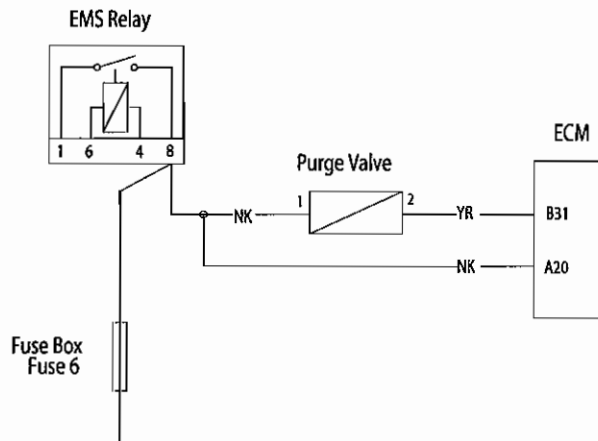

Fuel System/Engine Management

Ignition Coils

| Fault Code | Possible cause | Action |
|-------------|--|--|
| P0351/52/53 | Ignition system fault - Ign coil 1/2/3 | View & note diagnostic tool 'freeze frame' data if available. Ensure relevant ign coil connector is secure. Disconnect ECM and proceed to pinpoint test 1:- |

Pinpoint Tests

| Test | Result | Action |
|---|---------------------|---|
| 1 Check cable and terminal integrity: - ECM pin B29 - ECM pin B26 - ECM pin B01 | OK | Proceed to test 2 |
| | Faulty | Rectify fault, proceed to test 7 |
| 2 Check resistance value: ECM pin A20 to - ECM pin (ign coil 1) B29 - ECM pin (ign coil 2) B26 - ECM pin (ign coil 3) B01 | 1.4Ω to 1.8Ω | Proceed to test 3 |
| | Open circuit | Disconnect relevant ignition coil and proceed to test 4 |
| | Short circuit | Disconnect relevant ignition coil and proceed to test 5 |
| 3 Check cable for short circuit: - ECM pin to earth B29 - ECM pin to earth B26 - ECM pin to earth B01 | OK | Proceed to test 7 |
| | Short circuit | Locate and rectify wiring fault, proceed to test 7 |
| 4 Check cable continuity: Power latch relay pin 8 to any ign coil pin 2 - ECM pin B29 to ign coil 1 pin 1 - ECM pin B26 to ign coil 2 pin 1 - ECM pin B01 to ign coil 3 pin 1 | OK | Proceed to test 6 |
| | Open circuit | Locate and rectify wiring fault, proceed to test 7 |
| 5 Check cable for short circuit: ECM pin A20 to - ECM pin (ign coil 1) B29 - ECM pin (ign coil 2) B26 - ECM pin (ign coil 3) B01 | OK | Proceed to test 6 |
| | Short circuit | Locate and rectify wiring fault, proceed to test 7 |
| 6 Check relevant ign coil resistance: - Ign coil pin 1 to ign coil pin 2 | 1.4Ω to 1.8Ω | Proceed to test 7 |
| | Faulty | Renew relevant ignition coil, proceed to test 7 |
| 7 Reconnect harness, clear fault code and run engine to verify fault cleared | OK | Action complete - quit test |
| | Fault still present | Contact Triumph service |

Circuit Diagram

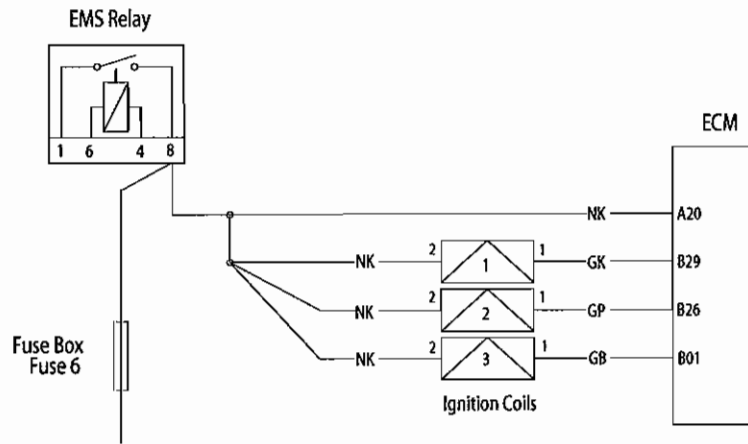

Fuel System/Engine Management

Coolant Temperature Sensor

| Fault Code | Possible cause | Action |
|------------|--|--|
| P0118 | Open circuit, or short circuit to battery+ | View & note diagnostic tool 'freeze frame' data if available. View & note diagnostic tool 'sensor' data. Ensure sensor connector is secure. Disconnect ECM and proceed to pinpoint test 1:- |
| P0117 | Short circuit to ground | Disconnect sensor and proceed to test 6 |

Pinpoint Tests

| Test | Result | Action |
|---|---------------|--|
| 1 Check cable and terminal integrity: - ECM pin A09 - ECM pin A07 | OK | Proceed to test 2 |
| | Faulty | Rectify fault, proceed to test 7 |
| 2 Check resistance value: - ECM pin A09 to ECM pin A07 (Temperature dependent, -see below) | OK | Disconnect temp sensor and proceed to test 6 |
| | Open circuit | Disconnect sensor and proceed to test 3 |
| | Short circuit | Disconnect temp sensor and proceed to test 4 |
| 3 Check cable continuity: - ECM pin A09 to sensor pin 1 - ECM pin A07 to sensor pin 2 | OK | Proceed to test 5 |
| | Open circuit | Locate and rectify wiring fault, proceed to test 7 |
| 4 Check cable for short circuit: - ECM pin A09 to ECM pin A07 | OK | Proceed to test 5 |
| | Short circuit | Locate and rectify wiring fault, proceed to test 7 |
| 5 Check sensor resistance: - Sensor pin 1 to sensor pin 2 (Temperature dependent, -see below) | OK | Proceed to test 7 |
| | Faulty | Renew temp sensor, proceed to test 7 |
| 6 Check cable for short circuit: - ECM pin A09 to ground | OK | Proceed to test 7 |
| | Short circuit | Locate and rectify wiring fault, proceed to test 7 |
| 7 Reconnect harness, clear fault code and run engine to verify fault cleared | OK | Action complete - quit test |
| | Fault | Contact Triumph service |

Circuit Diagram

Resistance data under typical conditions:

Warm engine: 200 to 400Ω

Cold engine:

20°C ambient 2.35 to 2.65KΩ

-10°C ambient 8.50 to 10.25KΩ

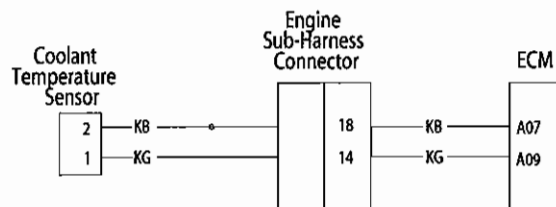

Fuel System/Engine Management

Inlet Air Temperature Sensor

| Fault Code | Possible cause | Action |
|------------|--|--|
| P0113 | Open circuit, or short circuit to battery+ | View & note diagnostic tool 'freeze frame' data if available. View & note diagnostic tool 'sensor' data. Ensure sensor connector is secure. Disconnect ECM and proceed to pinpoint test 1:- |
| P0112 | Short circuit to ground | Disconnect sensor and proceed to pinpoint test 6 |

Pinpoint Tests

| Test | Result | Action |
|---|---------------|--|
| 1 Check cable and terminal integrity: - ECM pin A22 - ECM pin A07 | OK | Proceed to test 2 |
| | Faulty | Rectify fault, proceed to test 7 |
| 2 Check resistance value: - ECM pin A22 to ECM pin A07 (Temperature dependent—see below) | OK | Disconnect temp sensor and proceed to test 6 |
| | Open circuit | Disconnect temp sensor and proceed to test 3 |
| | Short circuit | Disconnect temp sensor and proceed to test 4 |
| 3 Check cable continuity: - ECM pin A22 to sensor pin 1 - ECM pin A07 to sensor pin 2 | OK | Proceed to test 5 |
| | Open circuit | Locate and rectify wiring fault, proceed to test 7 |
| 4 Check cable for short circuit: - ECM pin A22 to ECM pin A07 | OK | Proceed to test 5 |
| | Short circuit | Locate and rectify wiring fault, proceed to test 7 |
| 5 Check sensor resistance: - Sensor pin 1 to sensor pin 2 (Temperature dependent—see below) | OK | Proceed to test 7 |
| | Faulty | Renew temp sensor, proceed to test 7 |
| 6 Check cable for short circuit: - ECM pin A22 to ground | OK | Proceed to test 7 |
| | Short circuit | Locate and rectify wiring fault, proceed to test 7 |
| 7 Reconnect harness, clear fault code and run engine to verify fault cleared | OK | Action complete - quit test |
| | Fault | Contact Triumph service |

Circuit Diagram

If engine is warm, remove sensor and allow time to cool to ambient prior to test.

Resistance data:

| Ambient temp | Resistance value |
|--------------|------------------|
| 80°C | 200 to 400Ω |
| 20°C | 2.35 to 2.65KΩ |
| -10°C | 8.50 to 10.25KΩ |

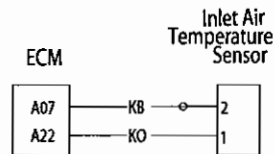

Fuel System/Engine Management

Fuel Pump Relay

| Fault Code | Possible cause | Action |
|------------|--|--|
| P1231 | Fuel pump relay open circuit, or short circuit to ground | Check if pump runs briefly when ignition is switched on. Ensure fuel pump relay connector is secure. Disconnect ECM and proceed to pinpoint test 1:- |
| P1232 | Short circuit to battery+ | Disconnect fuel pump relay and proceed to pinpoint test 4 |

Pinpoint Tests

| Test | Result | Action |
|---|---------------------|--|
| 1 Check cable and terminal integrity: - ECM pin B02 | OK | Disconnect fuel pump relay and proceed to test 2 |
| | Faulty | Rectify fault, proceed to test 5 |
| 2 Check cable for short circuit: - ECM pin B02 to earth | OK | Proceed to test 3 |
| | Short circuit | Locate and rectify wiring fault, proceed to test 5 |
| 3 Check cable continuity: - ECM pin B02 to fuel pump relay pin 4 - Fuel pump relay pin 6 to EMS relay pin 8 | OK | Proceed to test 4 |
| | Open circuit | Locate and rectify wiring fault, proceed to test 5 |
| 4 Check cable for short circuit: - ECM pin B02 to ECM pin A20 | OK | Proceed to test 5 |
| | Short circuit | Locate and rectify wiring fault, proceed to test 5 |
| 5 Reconnect harness, clear fault code and run diagnostic tool function test to verify fault cleared | OK | Action complete - quit test |
| | Fault still present | Contact Triumph service |

Circuit Diagram

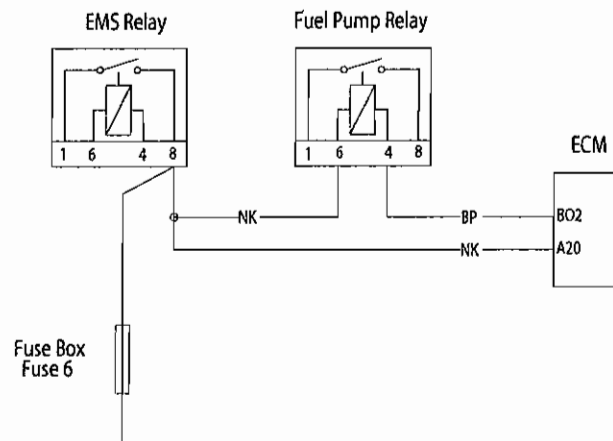

System Voltage

| Fault Code | Possible cause | Action |
|------------|---------------------------|--|
| P0560 | Bike voltage system fault | View & note diagnostic tool 'sensor' data. Ensure voltage across battery is acceptable, note voltage. |
| | | Disconnect ECM and proceed to pinpoint test 1 |

Pinpoint Tests

| Test | Result | Action |
|--|------------------------------------|--|
| 1 Check cable and terminal integrity: - ECM pin A20 | OK | Proceed to test 2 |
| | Faulty | Rectify fault, proceed to test 3 |
| 2 With Ignition 'on', check voltage at: - ECM pin A20 | Same as 'across battery' voltage | Proceed to test 3 |
| | Less than 'across battery' voltage | Locate and rectify wiring fault, proceed to test 3 |
| 3 Reconnect harness, clear fault code and run engine to verify fault cleared | OK | Action complete - quit test |
| | Fault still present | Contact Triumph service |

Circuit Diagram

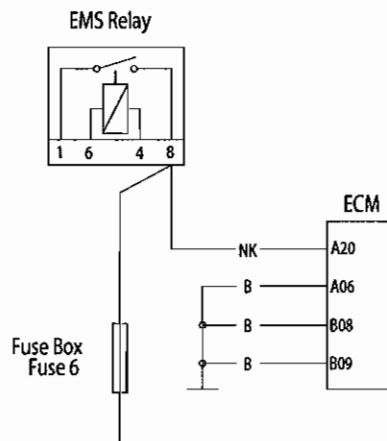

Fuel System/Engine Management

Cooling Fan Relay

| Fault Code | Possible cause | Action |
|------------|--|--|
| P1552 | Fan relay open circuit, or short circuit to ground | View & note diagnostic tool 'sensor' data. Ensure fan relay connector is secure. Disconnect ECM and proceed to pinpoint test 1:- |
| P1553 | Short circuit to battery+ | Disconnect fan relay and proceed to pinpoint test 4 |

Pinpoint Tests

| Test | Result | Action |
|---|---------------------|--|
| 1 Check cable and terminal integrity: - ECM pin B10 | OK | Disconnect fan relay and proceed to test 2 |
| | Faulty | Rectify fault, proceed to test 5 |
| 2 Check cable for short circuit: - ECM pin B10 to ground | OK | Proceed to test 3 |
| | Short circuit | Locate and rectify wiring fault, proceed to test 5 |
| 3 Check cable continuity: - Fan relay pin 4 to ECM pin B10 - Fan relay pin 6 to EMS relay pin 8 | OK | Proceed to test 4 |
| | Open circuit | Locate and rectify wiring fault, proceed to test 5 |
| 4 Check cable for short circuit: - ECM pin B10 to ECM pin A20 | OK | Proceed to test 5 |
| | Short circuit | Locate and rectify wiring fault, proceed to test 5 |
| 5 Reconnect harness, clear fault code and run diagnostic tool function test to visually verify operation of cooling fan | OK | Action complete - quit test |
| | Fault still present | Contact Triumph service |

Circuit Diagram

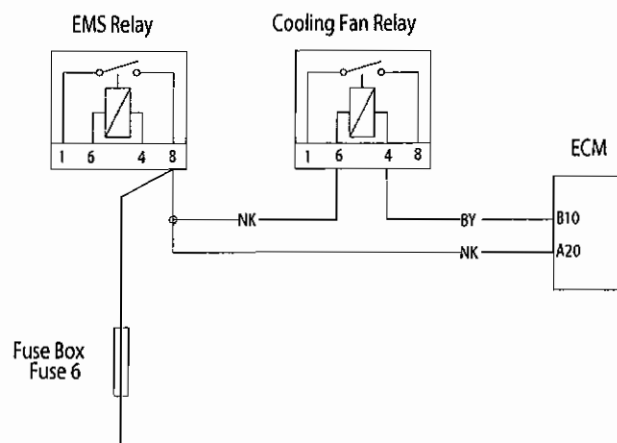

Tachometer

| Fault Code | Possible cause | Action |
|------------|-------------------------|--|
| P0654 | Tachometer system fault | View & note 'freeze frame' data if available. View & note 'sensor' data. Ensure instrument connector is secure. Disconnect ECM and proceed to pinpoint test 1:- |

Pinpoint Tests

| Test | Result | Action |
|---|---------------------|--|
| 1 Check cable and terminal integrity: - ECM pin B14 | OK | Disconnect instrument and proceed to test 2 |
| | Faulty | Rectify fault, proceed to test 5 |
| 2 Check cable for short circuit: - ECM pin B14 to ground | OK | Proceed to test 3 |
| | Short circuit | Locate and rectify wiring fault, proceed to test 5 |
| 3 Check cable continuity: - Instrument pin 1 to ECM pin B14 - Instrument pin 10 to earth - Instrument pin 2 to alarm control unit pin1 | OK | Proceed to test 4 |
| | Open circuit | Locate and rectify wiring fault, proceed to test 5 |
| 4 Check cable for short circuit: - ECM pin B14 to ECM pin A20 | OK | Renew instruments, proceed to test 5 |
| | Short circuit | Locate and rectify wiring fault, proceed to test 5 |
| 5 Reconnect harness, clear fault code and run diagnostic tool function test to visually verify operation of tachometer | OK | Action complete - quit test |
| | Fault still present | Contact Triumph service |

Circuit Diagram

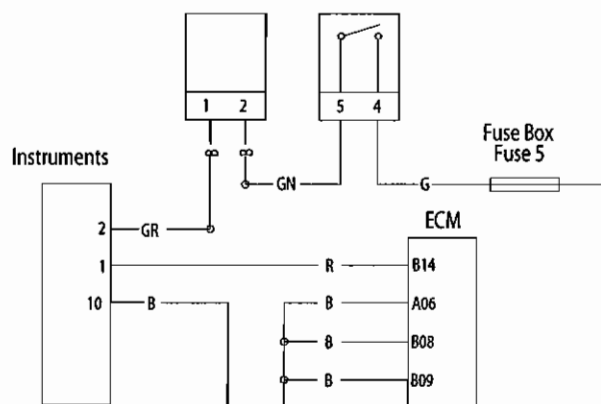

Fuel System/Engine Management

Coolant Temperature Indication

| Fault Code | Possible cause | Action |
|------------|-------------------------------------|--|
| P1115 | Temperature Indication system fault | View & note 'freeze frame' data if available. View & note 'sensor' data. Ensure instrument connector is secure. Disconnect ECM and proceed to pinpoint test 1:- |

Pinpoint Tests

| Test | Result | Action |
|--|---------------------|--|
| 1 Check cable and terminal integrity: - ECM pin B08 - ECM pin A06 - ECM pin B09 - ECM pin B34 | OK | Disconnect instruments and proceed to test 2 |
| | Faulty | Rectify fault, proceed to test 5 |
| 2 Check cable for short circuit: - ECM pin B34 to ground | OK | Proceed to test 3 |
| | Short circuit | Locate and rectify wiring fault, proceed to test 5 |
| 3 Check cable continuity: - Instrument pin 15 to ECM pin B34 - Instrument pin 10 to ground - Instrument pin 2 to alarm control unit pin 1 | OK | Proceed to test 4 |
| | Open circuit | Locate and rectify wiring fault, proceed to test 5 |
| 4 Check cable for short circuit: ECM pin B34 to ECM pin A20 | OK | Renew instruments, proceed to test 5 |
| | Short circuit | Locate and rectify wiring fault, proceed to test 5 |
| 5 Reconnect harness, clear fault code and run diagnostic tool function test to visually verify operation of instruments | OK | Action complete - quit test |
| | Fault still present | Contact Triumph service |

Circuit Diagram

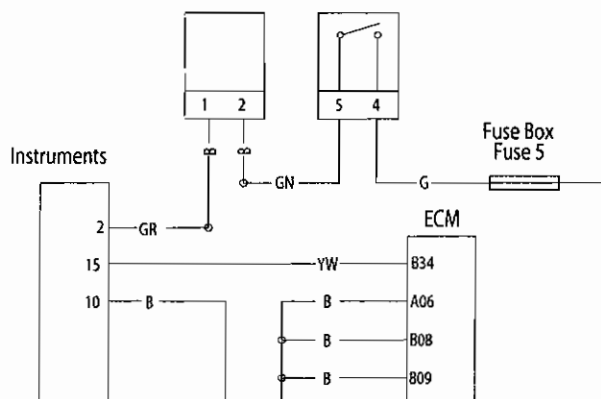

Vehicle Speed Output

| Fault Code | Possible cause | Action |
|------------|-----------------------------|--|
| P1500 | Vehicle Speed Circuit Fault | View & note 'freeze frame' data if available. View & note 'sensor' data. Ensure instrument connector is secure. Disconnect ECM and proceed to pinpoint test 1:- |

Pinpoint Tests

| Test | Result | Action |
|--|---------------------|--|
| 1 Check cable and terminal integrity: - ECM pin B32 - ECM pin B08 - ECM pin B09 - ECM pin A06 | OK | Disconnect instruments and proceed to test 2 |
| | Faulty | Rectify fault, proceed to test 5 |
| 2 Check cable for short circuit: - ECM pin B32 to ground | OK | Proceed to test 3 |
| | Short circuit | Locate and rectify wiring fault, proceed to test 5 |
| 3 Check cable continuity: - Instrument pin 13 to ECM pin B32 - Instrument pin 10 to ground - Instrument pin 2 to alarm control unit pin 1 | OK | Proceed to test 4 |
| | Open circuit | Locate and rectify wiring fault, proceed to test 5 |
| 4 Check cable for short circuit: ECM pin A20 to ECM pin B32 | OK | Renew instruments, proceed to test 5 |
| | Short circuit | Locate and rectify wiring fault, proceed to test 5 |
| 5 Reconnect harness, clear fault code and run diagnostic tool function test to visually verify operation of speedometer. | OK | Action complete - quit test |
| | Fault still present | Contact Triumph service |

Circuit Diagram

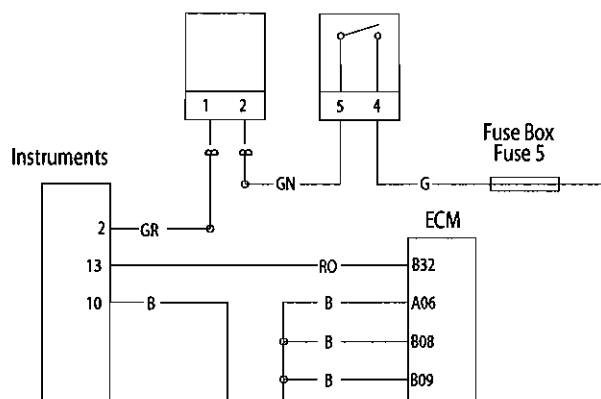

Fuel System/Engine Management

Lambda Sensor

| Fault Code | Possible cause | Action |
|------------|------------------------------|---|
| P0130 | Lambda sensor circuit fault. | View & note "freeze frame" data if available. View & note "sensor" data. Ensure sensor connector is secure. Disconnect ECM and proceed to pinpoint test 1: |

Pinpoint Tests

| Test | Result | Action |
|--|---------------------|--|
| 1 Check cable and terminal integrity: - ECM pin A11 - ECM pin A07 | OK | Disconnect lambda sensor and proceed to test 2 |
| | Faulty | Rectify fault, proceed to test 4 |
| 2 Check cable for short circuit: - ECM pin A11 to ECM pin A07 - ECM pin A11 to ECM pin A20 | OK | Proceed to test 3 |
| | Short circuit | Locate and rectify wiring fault, proceed to test 4 |
| 3 Check cable continuity: - ECM pin A11 to sensor pin 1 - ECM pin A11 to sensor pin 2 | OK | Proceed to test 4 |
| | Open circuit | Locate and rectify wiring fault, proceed to test 4 |
| 4 Reconnect harness, clear fault code and run engine. Check adaptation status. | OK | Action complete - quit test |
| | Fault still present | Contact Triumph service |

Circuit Diagram

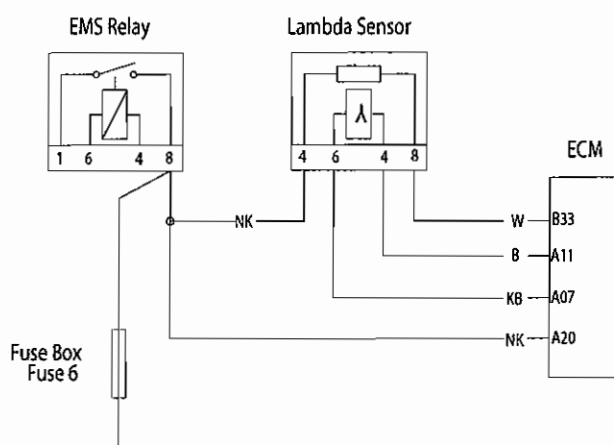

Lambda Sensor Heater

| Fault Code | Possible cause | Action |
|------------|---|---|
| P0031 | Lambda sensor heater circuit short circuit to ground or open circuit. | View & note "freeze frame" data if available. View & note "sensor" data. Ensure sensor connector is secure. Disconnect ECM and proceed to pinpoint test 1: |
| P0032 | Lambda sensor heater circuit, short circuit to battery. | Disconnect lambda sensor and proceed to pinpoint test 4 |

Pinpoint Tests

| Test | Result | Action |
|---|---------------------|--|
| 1 Check cable and terminal integrity: - Ecm pin B33 | OK | Disconnect lambda sensor and proceed to test 2 |
| | Faulty | Rectify fault, proceed to test 5 |
| 2 Check cable for short circuit: - ECM pin A33 to ground | OK | Proceed to test 3 |
| | Short circuit | Locate and rectify wiring fault, proceed to test 5 |
| 3 Check cable continuity: - ECM pin B33 to sensor pin 3 - ECM pin A20 to sensor pin 4 | OK | Proceed to test 5 |
| | Open circuit | Locate and rectify wiring fault, proceed to test 5 |
| 4 Check cable for short circuit: - ECM pin B33 to ECM pin A20 | OK | Renew lambda sensor and proceed to test 5 |
| | Short circuit | Locate and rectify wiring fault, proceed to test 5 |
| 5 Reconnect harness, clear fault code and run engine. Check adaption status. | OK | Action complete, quit test |
| | Fault still present | Contact Triumph service |

Circuit Diagram

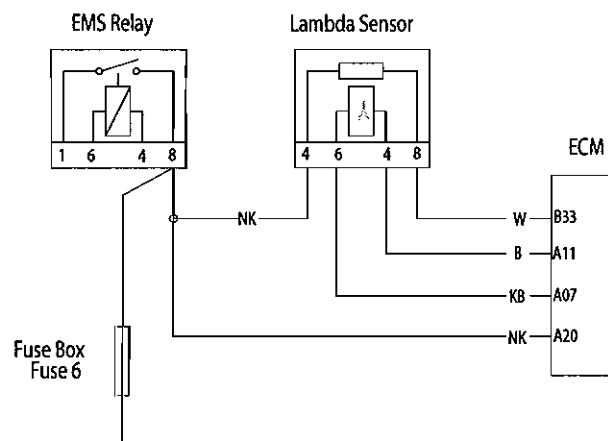

Fuel System/Engine Management

EEPROM Error

| Fault Code | Possible cause | Action |
|------------|----------------|--|
| P0603 | EEPROM error | View & note "freeze frame" data if available. No tests available - contact Triumph service. |

Fall Detection Switch

| Fault Code | Possible cause | Action |
|------------|--|--|
| P1631 | Fall detection switch low input voltage | View & note "freeze frame" data if available. |
| P1632 | Fall detection switch high input voltage or open circuit | View & note "sensor" data Ensure switch connector is secure. Disconnect ECM and proceed to pinpoint test1: |

Pinpoint Tests

| Test | Result | Action |
|--|-----------------------|--|
| 1 Check cable and terminal integrity: - ECM pin A04 | OK | Disconnect sensor and proceed to test 2 |
| | Faulty | Rectify fault, proceed to test 6 |
| 2 Check cable for short circuit: - ECM pin A04 to ground - ECM pin A04 to ECM pin A20 | OK | Proceed to test 3 |
| | Short circuit | Locate and rectify wiring fault, proceed to test 6 |
| 3 Check cable continuity: - ECM pin A01 to sensor pin 4 - ECM pin A04 to sensor pin 5 - ECM pin A07 to sensor pin 6 | OK | Proceed to test 4 |
| | Open circuit | Locate and rectify wiring fault, proceed to test 6 |
| 4 Check cable for short circuit: - Sensor pin 4 to sensor pin 5 - Sensor pin 4 to sensor pin 6 | OK | Proceed to test 5 |
| | Short circuit | Locate and rectify wiring fault, proceed to test 6 |
| 5 Check voltage (with ignition on): - Sensor pin 4 | 12V (battery voltage) | Renew fall detection switch and proceed to test 6 |
| | Less than 12V | Locate and rectify wiring fault, proceed to test 6 |
| 6 Reconnect harness, clear fault code. | OK | Action complete, quit test |
| | Fault still present | Contact Triumph service |

Circuit Diagram

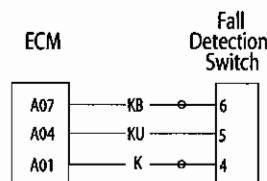

Fuel System/Engine Management

2nd Throttle Position Sensor

| Fault Code | Possible cause | Action |
|------------|---|---|
| P0222 | 2nd throttle position sensor low voltage. (short circuit to ground or open circuit) | View & note "freeze frame" data if available. |
| P0223 | | View & note "sensor" data Ensure sensor connector is secure. |
| | 2nd throttle position sensor high voltage. (short circuit to sensor supply) | Disconnect ECM and proceed to pinpoint test1: |

Pinpoint Tests

| Test | Result | Action |
|--|---------------------|--|
| 1 Check cable and terminal integrity: - ECM pin A01 - ECM pin A07 - ECM pin A02 | OK | Disconnect sensor and proceed to test 2 |
| | Faulty | Rectify fault, proceed to test 5 |
| 2 Check cable for short circuit: - ECM pin A02 to ground | OK | Proceed to test 3 |
| | Short circuit | Locate and rectify wiring fault, proceed to test 5 |
| 3 Check cable continuity: - ECM pin A01 to sensor pin 1 - ECM pin A07 to sensor pin 2 - ECM pin A02 to sensor pin 3 | OK | Proceed to test 4 |
| | Open circuit | Locate and rectify wiring fault, proceed to test 5 |
| 4 Check cable for short circuit: - ECM pin A02 to ECM pin A01 - ECM pin A02 to ECM pin A07 | OK | Renew 2nd throttle position sensor and proceed to test 5 |
| | Short circuit | Locate and rectify wiring fault, proceed to test 5 |
| 5 Reconnect harness, clear fault code. | OK | Action complete, quit test |
| | Fault still present | Contact Triumph service |

Circuit Diagram

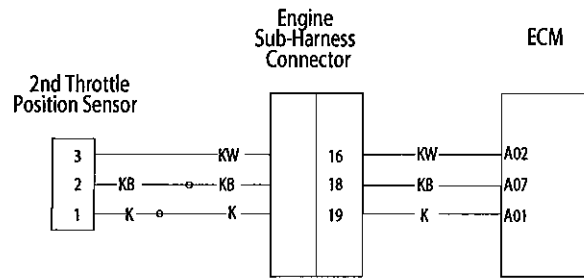

Fuel System/Engine Management

2nd Throttle Actuator

| Fault Code | Possible cause | Action |
|------------|--|---|
| P0638 | 2nd throttle actuator motor / wiring fault | View & note "freeze frame" data if available. View & note "sensor" data Ensure actuator connector is secure. Disconnect ECM and proceed to pinpoint test1: |

Pinpoint Tests

| Test | Result | Action |
|---|---------------------|--|
| 1 Check cable and terminal integrity: - ECM pin B21 - ECM pin B22 - ECM pin B12 - ECM pin B04 | OK | Proceed to test 2 |
| | Faulty | Rectify fault, proceed to test 7 |
| 2 Check resistance value: - ECM pin B21 to ECM pin B22 - ECM pin B12 to ECM pin B04 | 4Ω to 10Ω | Disconnect actuator and proceed to test 3 |
| | Open circuit | Proceed to test 4 |
| | Short circuit | Disconnect actuator and proceed to test 5 |
| 3 Check cable continuity: - ECM pin B21 to ground - ECM pin B22 to ground - ECM pin B12 to ground - ECM pin B04 to ground | OK | Proceed to test 7 |
| | Short circuit | Locate and rectify wiring fault, proceed to test 7 |
| 4 Check cable continuity: - ECM pin B21 to actuator pin A - ECM pin B22 to actuator pin A - ECM pin B12 to actuator pin B - ECM pin B04 to actuator pin B | OK | Proceed to test 6 |
| | Open circuit | Locate and rectify wiring fault, proceed to test 7 |
| 5 Check cable for short circuit: - ECM pin B21 to ECM pin B22 - ECM pin B12 to ECM pin B04 | OK | Proceed to test 6 |
| | Short circuit | Locate and rectify wiring fault, proceed to test 7 |
| 6 Check actuator resistance: - Sensor pin A to sensor pin A - Sensor pin B to sensor pin B | 4Ω to 10Ω | Proceed to test 7 |
| | | renew actuator and proceed to test 7 |
| 7 Reconnect harness, clear fault code. Run diagnostic tool function test to visually verify operation of actuator | OK | Action complete, quit test |
| | Fault still present | Contact Triumph service |

Circuit Diagram

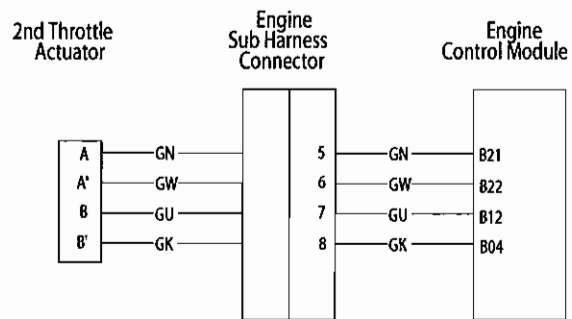

Fuel System/Engine Management

Vehicle Speed Sensor

| Fault Code | Possible cause | Action |
|------------|------------------------------------|---|
| P0500 | Vehicle speed sensor circuit fault | View & note "freeze frame" data if available. View & note "sensor" data Ensure sensor connector is secure. Disconnect ECM and proceed to pinpoint test1: |

Pinpoint Tests

| Test | Result | Action |
|--|---------------------|--|
| 1 Check cable and terminal integrity: - ECM pin A21 - Instrument pin 18 | OK | Disconnect ambient pressure sensor and proceed to test 2 |
| | Faulty | Rectify fault, proceed to test 4 |
| 2 Check cable for short circuit: - ECM pin A21 to ground - ECM pin A21 to ECM pin A01 - ECM pin A21 to battery | OK | Proceed to test 3 |
| | Faulty | Locate and rectify wiring fault, proceed to test 4 |
| 3 Check cable for continuity: - ECM pin A21 to sensor pin 3 - Sensor pin 2 to ground - Instruments pin 18 to sensor pin 1 | OK | Renew vehicle speed sensor and proceed to test 4 |
| | Open circuit | Locate and rectify wiring fault, proceed to test 4 |
| 4 Reconnect harness, clear fault code and run engine. | OK | Action complete, quit test |
| | Fault still present | Contact Triumph service |

Circuit Diagram

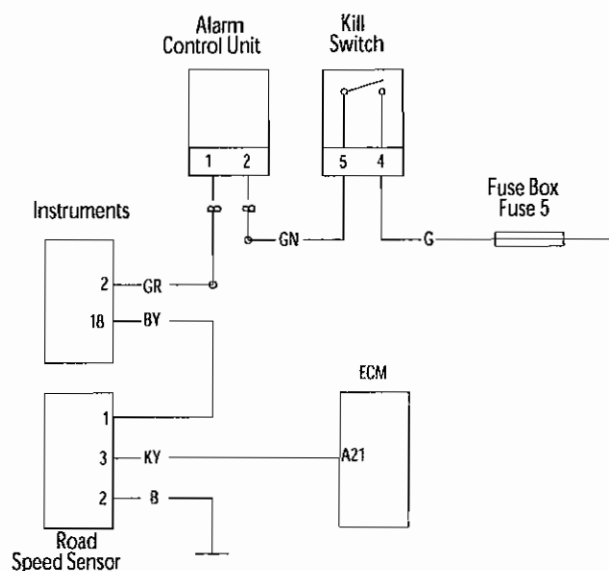

Ambient Pressure Sensor

| Fault Code | Possible cause | Action |
|------------|--|---|
| P1107 | Ambient pressure sensor circuit short circuit to ground | View & note "freeze frame" data if available. View & note "sensor" data. Ensure sensor connector is secure. Disconnect ECM and proceed to pinpoint test 1: |
| P1108 | Ambient pressure sensor circuit, short circuit to supply or open circuit | Disconnect ambient pressure sensor and proceed to pinpoint test 4. |

Pinpoint Tests

| Test | Result | Action |
|--|---------------------|--|
| 1 Check cable and terminal integrity: - ECM pin A23 - ECM pin A07 - ECM pin A01 | OK | Disconnect ambient pressure sensor and proceed to test 2 |
| | Faulty | Rectify fault, proceed to test 5 |
| 2 Check cable for short circuit: - ECM pin A23 to ECM A07 | OK | Proceed to test 3 |
| | Short circuit | Locate and rectify wiring fault, proceed to test 5 |
| 3 Check cable for continuity: - ECM pin A23 to sensor pin 3 - ECM pin A07 to sensor pin 2 - ECM pin A01 to sensor pin 1 | OK | Renew ambient pressure sensor and proceed to test 5 |
| | Open circuit | Locate and rectify wiring fault, proceed to test 5 |
| 4 Check cable for short circuit: - ECM pin A23 to ECM pin A01 | OK | Renew ambient pressure sensor and proceed to test 5 |
| | Short circuit | Locate and rectify wiring fault, proceed to test 5 |
| 5 Reconnect harness, clear fault code and run engine | OK | Action complete, quit test |
| | Fault still present | Contact Triumph service |

Circuit Diagram

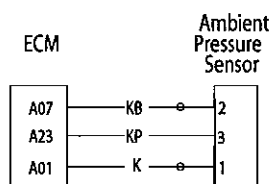

Fuel System/Engine Management

Manifold Absolute Pressure (Map) Sensor

| Fault Code | Possible cause | Action |
|------------|---|---|
| P0107 | MAP sensor circuit short circuit to ground | View & note "freeze frame" data if available. View & note "sensor" data Ensure sensor connector is secure. Disconnect ECM and proceed to pinpoint test1: |
| P0108 | MAP sensor circuit, short circuit to supply or open circuit | Disconnect MAP sensor and proceed to test 4 |
| P1105 | MAP sensor pipe fault | Check connection/condition of pipe from MAP sensor to throttle body |

Pinpoint Tests

| Test | Result | Action |
|--|---------------------|--|
| 1 Check cable and terminal integrity: - ECM pin A03 - ECM pin A07 - ECM pin A01 | OK | Disconnect MAP sensor and proceed to test 2 |
| | Faulty | Rectify fault, proceed to test 5 |
| 2 Check cable for short circuit: - ECM pin A03 to ECM A07 | OK | Proceed to test 3 |
| | Short circuit | Locate and rectify wiring fault, proceed to test 5 |
| 3 Check cable for continuity: - ECM pin A03 to sensor pin 3 - ECM pin A07 to sensor pin 2 - ECM pin A01 to sensor pin 1 | OK | Renew MAP sensor and proceed to test 5 |
| | Open circuit | Locate and rectify wiring fault, proceed to test 5 |
| 4 Check cable for short circuit: - ECM pin A03 to ECM pin A01 | OK | Renew MAP sensor and proceed to test 5 |
| | Short circuit | Locate and rectify wiring fault, proceed to test 5 |
| 5 Reconnect harness, clear fault code and run engine | OK | Action complete, quit test |
| | Fault still present | Contact Triumph service |

Circuit Diagram

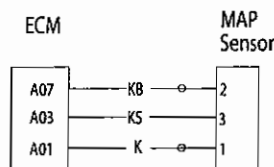

Gear Position Sensor

| Fault Code | Possible cause | Action |
|------------|------------------------------------|---|
| P0705 | Gear position sensor circuit fault | View & note "freeze frame" data if available. View & note "sensor" data Ensure sensor connector is secure. Disconnect ECM and proceed to pinpoint test1: |

Pinpoint Tests

| Test | Result | Action |
|---|---------------------|--|
| 1 Check cable and terminal integrity: - ECM pin A26 | OK | Disconnect sensor and proceed to test 2 |
| | Faulty | Rectify fault, proceed to test 5 |
| 2 Check cable for short circuit: - ECM pin A26 to ground | OK | Proceed to test 3 |
| | Short circuit | Locate and rectify wiring fault, proceed to test 5 |
| 3 Check cable continuity: - ECM pin A26 to sensor pin 1 - ECM pin A19 to sensor pin 2 | OK | Proceed to test 4 |
| | Open circuit | Locate and rectify wiring fault, proceed to test 5 |
| 4 Check cable for short circuit: - Sensor pin 1 to sensor pin 2 | OK | Renew gear position sensor and contact pin and proceed to test 5 |
| | Short circuit | Locate and rectify wiring fault, proceed to test 5 |
| 5 Reconnect harness, clear fault code. | OK | Action complete, quit test |
| | Fault still present | Contact Triumph service |

Circuit Diagram

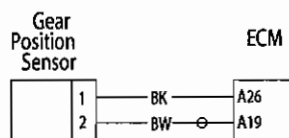

Fuel System/Engine Management

Fuel Level Sensor Circuit

| Fault Code | Possible cause | Action |
|------------|---------------------------------|---|
| P0460 | Fuel level sensor circuit fault | View & note "freeze frame" data if available. View & note "sensor" data Ensure sensor connector is secure. Disconnect ECM and proceed to pinpoint test1: |

Pinpoint Tests

| Test | Result | Action |
|---|---------------------|--|
| 1 Check cable and terminal integrity: - ECM pin A24 - ECM pin A06 | OK | Disconnect sensor and proceed to test 2 |
| | Faulty | Rectify fault, proceed to test 6 |
| 2 Check cable for short circuit: - ECM pin A24 to ground | OK | Proceed to test 3 |
| | Short circuit | Locate and rectify wiring fault, proceed to test 5 |
| 3 Check cable continuity: - ECM pin A24 to sensor pin 4 - ECM pin A06 to sensor pin 3 | OK | Proceed to test 4 |
| | Open circuit | Locate and rectify wiring fault, proceed to test 5 |
| 4 Check cable for short circuit: - Sensor pin 3 to sensor pin 4 | OK | Renew fuel level sensor and proceed to test 5 |
| | Short circuit | Locate and rectify wiring fault, proceed to test 5 |
| 5 Reconnect harness, clear fault code. | OK | Action complete, quit test |
| | Fault still present | Contact Triumph service |

Circuit Diagram



Fuel Level Warning Light Circuit

| Fault Code | Possible cause | Action |
|------------|----------------------------|---|
| P1610 | Low fuel alarm light fault | Ensure instrument connector is secure. Disconnect ECM and proceed to pinpoint test1: |

Pinpoint Tests

| Test | Result | Action |
|---|---------------------|--|
| 1 Check cable and terminal integrity: - ECM pin A30 - Instrument pin 4 | OK | Proceed to test 2 |
| | Faulty | Rectify fault, proceed to test 4 |
| 2 Check cable for short circuit: - ECM pin A30 to ground | OK | Disconnect instrument assembly and proceed to test 3 |
| | Short circuit | Locate and rectify wiring fault, proceed to test 4 |
| 3 Check cable continuity: - ECM pin A30 to instrument pin 4 - Instrument pin 10 to ground - Instrument pin 2 to alarm control unit pin 1 | OK | Renew instruments and proceed to test 4 |
| | Open circuit | Locate and rectify wiring fault, proceed to test 4 |
| 4 Reconnect harness, clear fault code and run diagnostic tool function test to visually verify operation of instruments | OK | Action complete, quit test |
| | Fault still present | Contact Triumph service |

Circuit Diagram

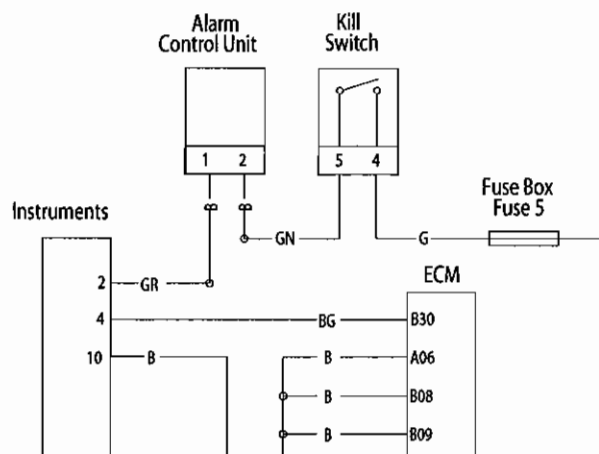

Fuel System/Engine Management

Fuel Level Gauge

| Fault Code | Possible cause | Action |
|------------|--|---|
| P0656 | Accessory fuel level gauge circuit fault | Ensure fuel level gauge connector is secure. Disconnect ECM and proceed to pinpoint test1: |

Pinpoint Tests

| Test | Result | Action |
|--|---------------------|--|
| 1 Check cable and terminal integrity: - ECM pin A08 - Gauge pin 1 | OK | Disconnect gauge and proceed to test 2 |
| | Faulty | Rectify fault, proceed to test 4 |
| 2 Check cable for short circuit: - ECM pin A08 to ground - ECM pin A08 to ECM pin A20 | OK | Proceed to test 3 |
| | Short circuit | Locate and rectify wiring fault, proceed to test 4 |
| 3 Check cable continuity: - ECM pin A08 to gauge pin 1 - Gauge pin 2 to earth - Gauge pin 3 to alarm control unit pin 1 | OK | Renew gauge and proceed to test 4 |
| | Open circuit | Locate and rectify wiring fault, proceed to test 4 |
| 4 Reconnect harness, clear fault code. | OK | Action complete, quit test |
| | Fault still present | Contact Triumph service |

Circuit Diagram

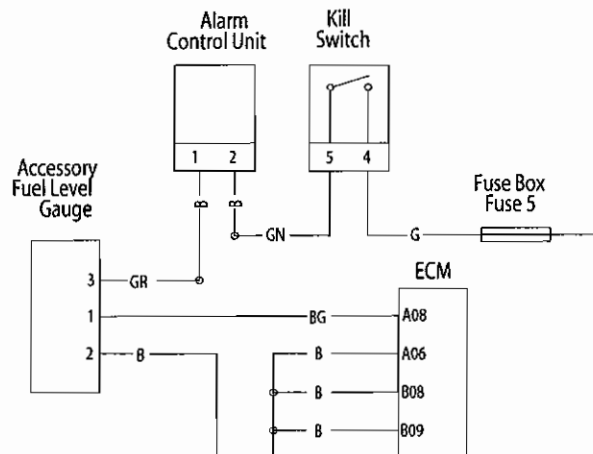

Fault Finding - Non Electrical

| Symptom | Possible cause(s) |
|---|--|
| Poor throttle response at low RPM | Low fuel pressure caused by filter blockage/leaks |
| | Low fuel pressure caused by loose fuel pipes to the fuel pump and filter |
| Cutting out at idle | Throttle bodies out of balance |
| | ISC (Idle Speed Control) actuator inoperative |
| | Low fuel pressure caused by loose fuel pipes to the fuel pump and filter. |
| | Low fuel pressure |
| | Weak mixture caused by air leak at the throttle body/ transition piece to cylinder head face |
| Idle speed too low/high | ISC (Idle Speed Control) actuator sticking |
| | Incorrect closed throttle position setting |
| | Mechanical fault with the throttle linkage |
| Diagnostic tool malfunctions during tune download procedure | Low battery voltage |
| Throttle hang-up | Incorrect closed throttle position setting |
| Bike will start but cuts out immediately | Low fuel pressure caused by loose fuel pipes to the fuel pump and filter. |
| | Low fuel pressure due to split fuel filter |
| | ISC motor stuck |
| Abnormally high fuel pressure | Fuel pressure regulator inoperative. |
| Temperature gauge reads cooler than normal | Cooling system air-locked resulting in coolant temperature sensor operating in air instead of coolant. |

Fuel System/Engine Management

Fuel Tank

Note:

- The fuel tank may be raised without being removed completely, for access to the top of the engine, ignition coils, spark plugs etc.

Warning

Observe the warning advice given in the general information section on the safe handling of fuel and fuel containers.

A fire, causing personal injury and damage to property could result from spilled fuel or fuel not handled or stored correctly.

Fuel tank - raising

1. Remove the rider's seat.
2. Disconnect the battery negative (black) lead first.
3. Release the two fixings securing the instrument pack to the handlebar clamp cover.

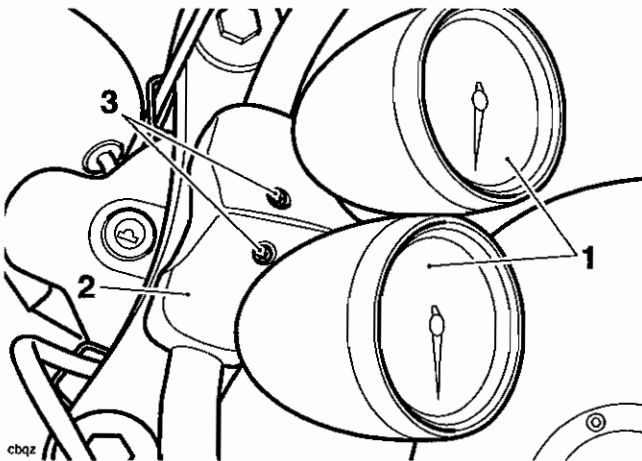

- cbqz
1. Instrument pack
 2. Handlebar clamp cover
 3. Fixings

4. Tilt the instruments forward.

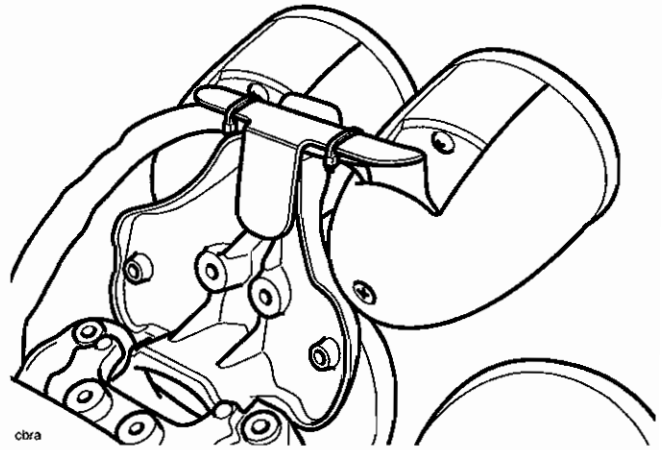

- cbra
5. Remove the intake cover from the left hand side of the tank as follows, release the two screws from its front and rear edges and then slide it downwards to release it from two support studs in its centre.

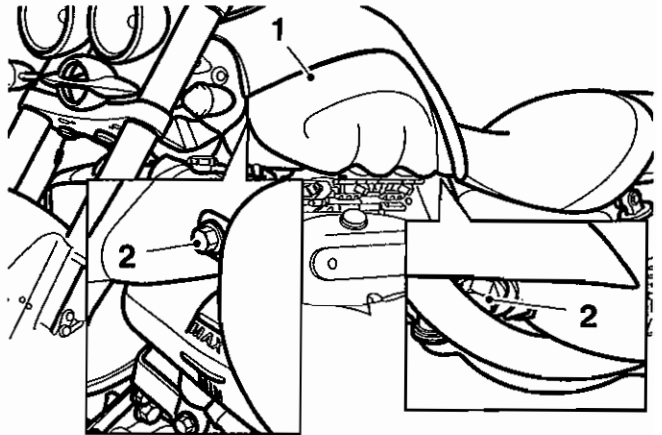

- cbrb
1. Intake cover
 2. Intake cover screws

6. Release the single fixing from the front of the fuel tank.

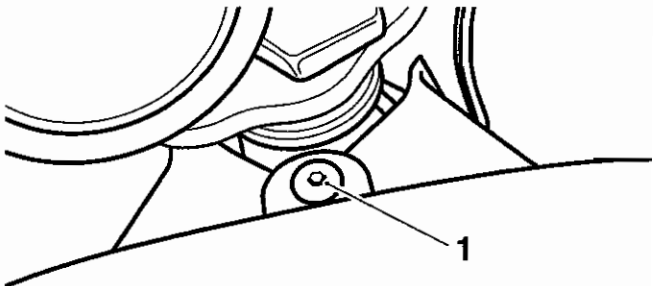

- cbrl
1. Fixing

- Pivot the fuel tank upwards at the front, support the tank while detaching the tank prop from two clips on the outside of the coil bracket.

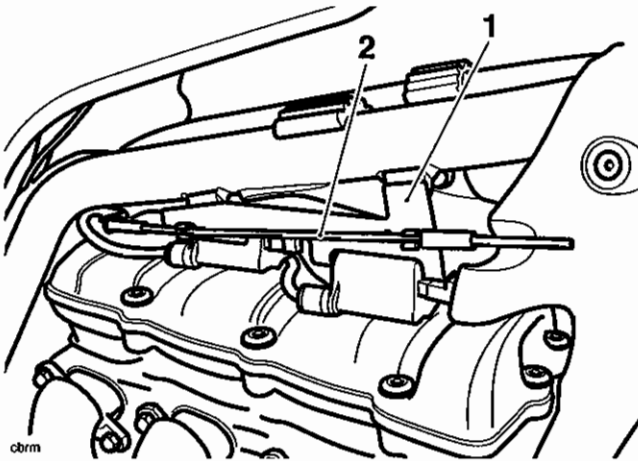

- Coil bracket
- Fuel tank prop

- Locate the plain end of the prop in the fuel tank fixing hole and the spherical end in the fixing bracket on the tank.

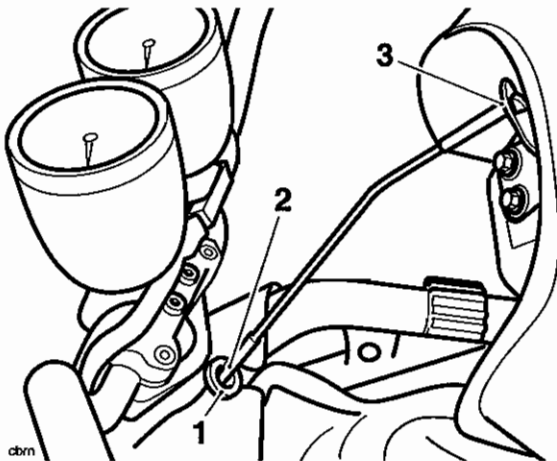

- Fuel tank fixing hole
- Prop – plain end
- Prop- ball end

Fuel tank - lowering and securing

- Support the tank and remove the tank prop.
- Continue to support the tank while refitting the prop to the two clips on the outside side of the coil bracket.

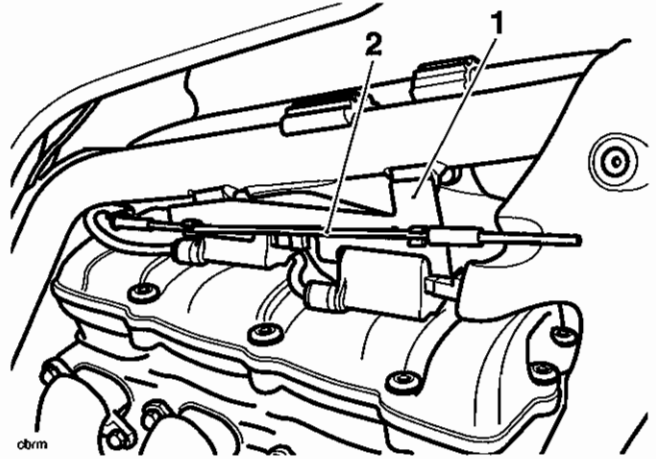

- Coil bracket
- Fuel tank prop

- Lower the tank into position and secure with the forward fixing. Tighten the fixing to **9 Nm**.
- Refit the intake cover as follows; align the cover to the centre studs and ease it into place. Fit and tighten the two screws to **9 Nm**.
- Pivot the instruments into place. Fit the two screws and tighten to **3 Nm**.
- Reconnect the battery, positive (red) lead first.
- Refit the rider's seat as described on page 17.9.

Fuel System/Engine Management

Fuel tank – removal

1. Raise and prop the tank as described on page 11.98.
2. Make a note of, or mark the position of the two breather hoses at the front left side of the tank, before disconnecting both hoses.

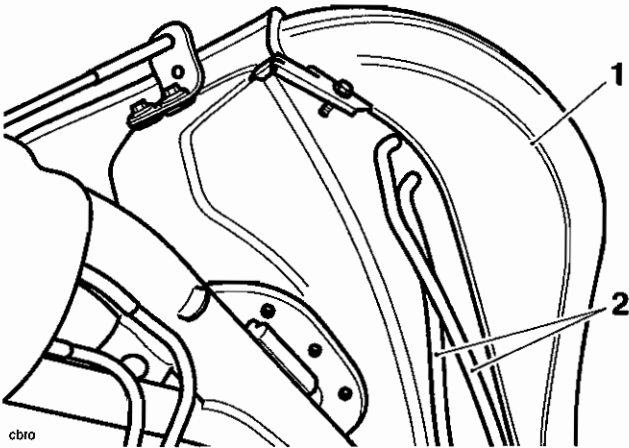

1. Fuel tank
2. Breather hoses

Warning

The fuel pipe will contain fuel under pressure. When releasing the fuel pipe union, wear eye protection and protective clothing and ensure that the pressurised fuel is not exposed to naked flames, light bulbs, etc. A fire, causing personal injury and damage to property, may result from fuel exposure to naked flames, light bulbs and any other source of ignition.

Note:

- The fuel supply system is fitted with a check valve to prevent fuel flow from the tank when the hose is disconnected. It is not necessary to plug the connection.

3. Disconnect the fuel pipe from the fuel pump plate in the base of the tank and discard the sealing washers. Drain the pipe contents into a suitable fuel container.

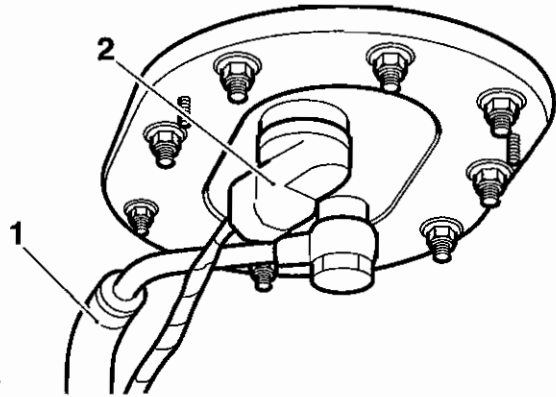

1. Fuel hose
2. Electrical connection

4. Disconnect the electrical connection from the fuel pump plate.
5. Support the fuel tank while removing the rear mounting bolt.

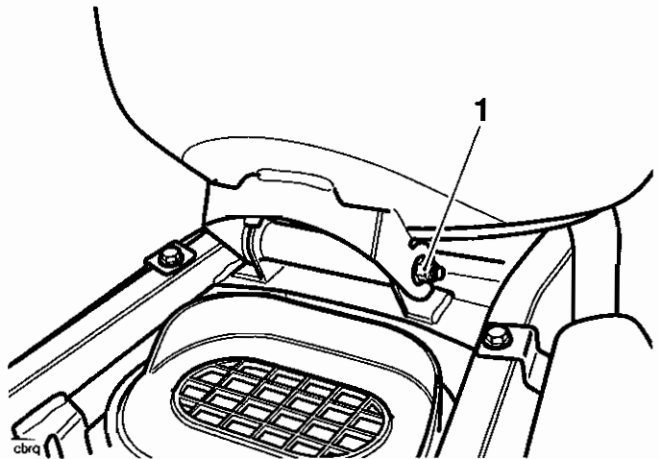

1. Rear mounting bolt

6. Raise the tank from the frame and have a colleague collect the tank prop.

Note:

- Store the tank prop in a convenient place, ready for when the tank is refitted.
7. Place the fuel tank in a safe place.

Fuel tank - refit

1. Position the fuel tank to the frame and install the rear mounting bolt.
2. Pivot the front of the tank upwards at the front and refit the tank prop to the frame and tank
3. Tighten the rear fuel tank mounting bolt to **9 Nm**.
4. Incorporating new washers, refit the fuel hose and tighten the union to **15 Nm**.
5. Reconnect the electrical supply to the fuel pump plate.
6. Connect the breather hoses as noted/marked prior to removal.
7. Lower and secure the fuel tank as described on page 11.99.

Fuel Pump, Filter and Pressure Regulator

Removal

1. Remove the fuel tank as described on page 11.100.



Observe the warning advice given in the general information section on the safe handling of fuel and fuel containers.

A fire, causing personal injury and damage to property could result from spilled fuel or fuel not handled or stored correctly.



Never drain fuel from the tank using non-approved, non-professional standard fuel handling equipment. A fire causing destruction of property and injury to persons may result from use of non-approved fuel handling equipment.

2. Using proprietary professional automotive workshop equipment approved for fuel handling, drain all fuel from the fuel tank.
3. Invert the fuel tank and place on a protective surface to prevent paint damage.
4. Release the ring of nuts securing the fuel pump mounting plate to the tank.

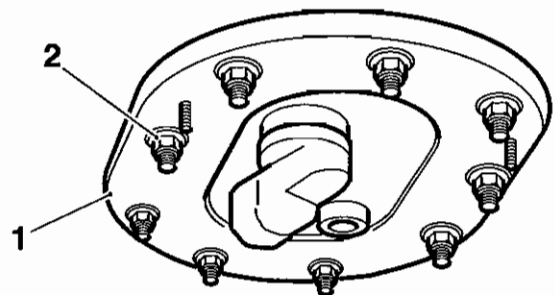

obs

1. Fuel pump mounting plate
2. Nuts

Fuel System/Engine Management

5. Separate the pump/filter/regulator assembly from the fuel tank. Discard the pump plate seal.

Caution

Ensure that the fuel level sensor's float arm is not damaged during removal of the fuel pump mounting plate. A damaged float arm will result in an incorrectly operating low fuel warning light.

Note:

- To remove the pressure regulator, filter and pump, components must be removed in sequence, as follows below/over.
6. Release the screw securing the pressure regulator to the mounting bar.

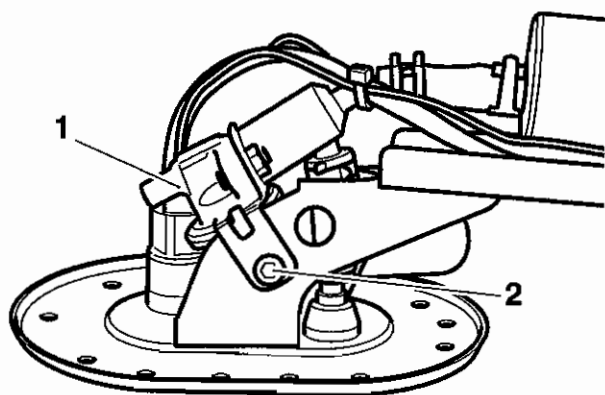

cbpa

1. Screw
2. Pressure regulator

Note:

- Unless it cannot be avoided, do not cut the tie securing the internal wiring to the fuel pressure regulator. Instead, release the two wiring connectors from the pump plate (note or mark their positions before removal).

7. To release the pressure regulator, release the hose clips from the pump plate and filter then gently ease the regulator, link pipe and hoses upwards. Place the regulator aside.

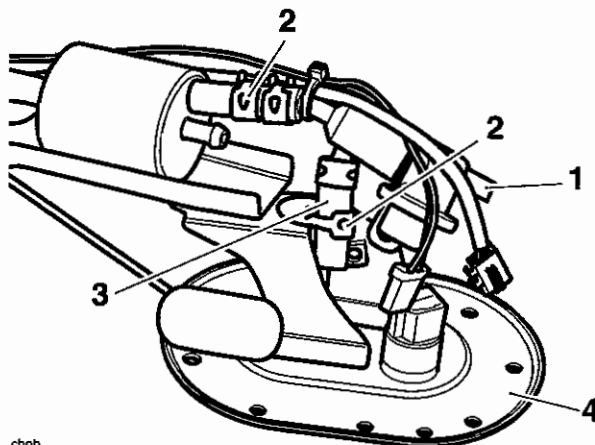

cbpb

1. Pressure regulator
2. Hose clips
3. Link pipe
4. Pump mounting plate

Note:

- Prior to removing the filter, note the direction of the arrow on the side of the filter. The arrow should point away from the fuel pump, towards the pressure regulator.
8. To release the filter, release the hose clip and gently ease the filter from the inlet hose.

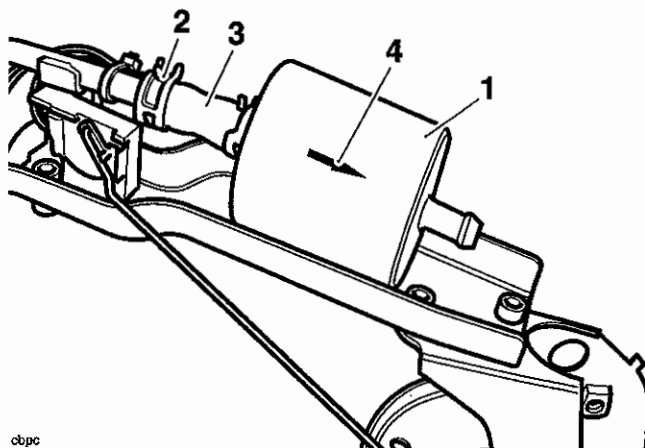

cbpc

1. Filter
2. Clip
3. Inlet hose
4. Filter arrow

9. Release the screw securing the fuel pipe bracket and fuel level sensor to the mounting bar.

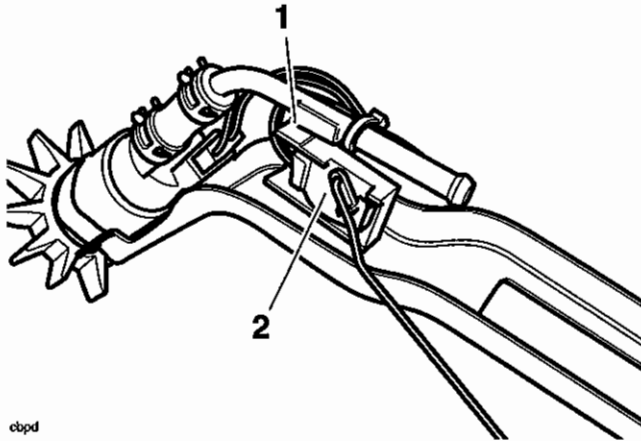

cbpd

1. Fuel pipe bracket
2. Fuel level sensor

10. Disconnect the electrical connection from the pump.

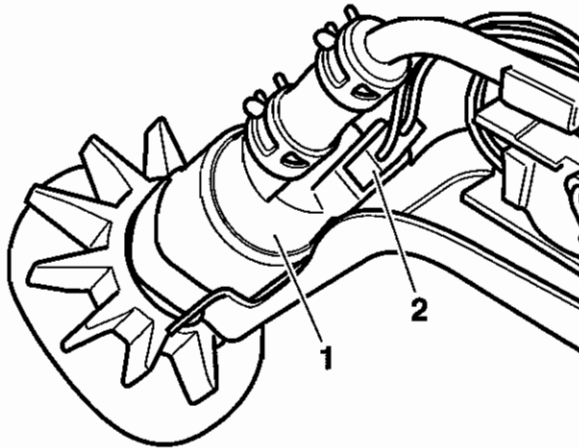

cbpe

1. Fuel pump
2. Electrical connection

11. Release the clip securing the remaining fuel hose to the pump, then ease the fuel pipe away from the filter.

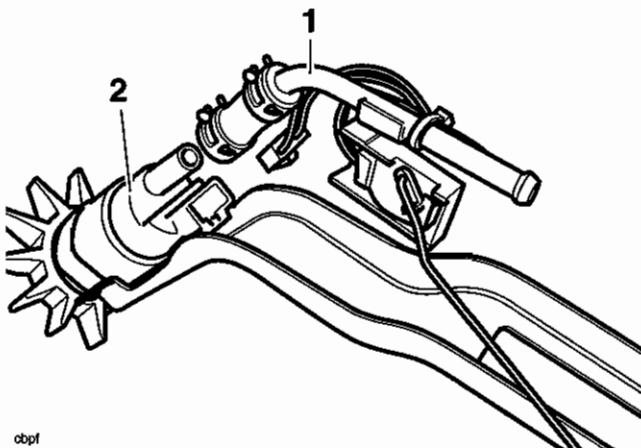

cbpf

1. Fuel pipe
2. Pump

12. Release the screw securing the fuel pump clamp to its mounting bar. Discard the screw after removal.

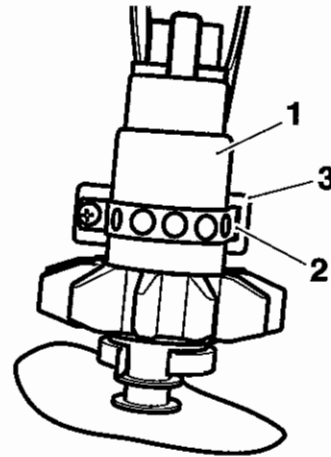

cbpg

1. Fuel pump
2. Fuel pump clamp
3. Mounting bar

13. The pump may now be removed.

Inspection

1. Inspect all hoses for cracks, splits, fraying and other damage. Replace as necessary.
2. Check all hose clips for cracks and signs of distortion. Replace as necessary.

Assembly

1. Position the fuel pump to the mounting bar, ensuring the feet of the rubber isolator engage correctly in the fork.

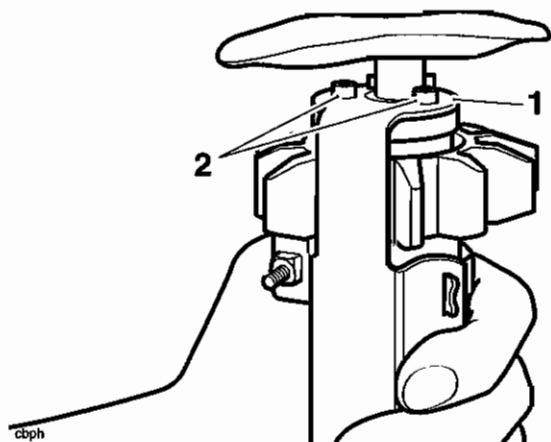

cbph

1. Fork
2. Isolator feet

Fuel System/Engine Management

2. Refit the pump clamp and tighten a new screw to **2 Nm**.

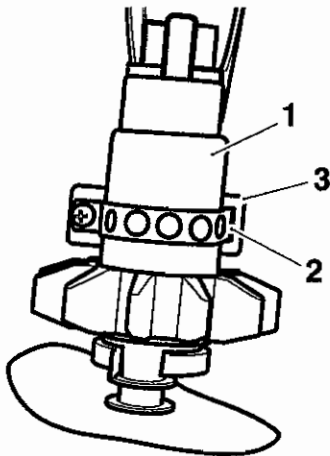

cbpg

1. Fuel pump
2. Fuel pump clamp
3. Mounting bar

3. Locate the fuel pipe and hose to the pump outlet.
4. Making sure that the anti-rotation tab is located in its slot, align the fuel pipe and fuel level sender to the screw hole in the mounting bar. Fit a new screw and tighten it to **10 Nm**.
5. Position the hose clip on the fuel pipe to the outlet spigot on the pump.
6. Refit/replace the filter (arrow pointing away from the pump) by engaging it with the hose on the fuel pipe.

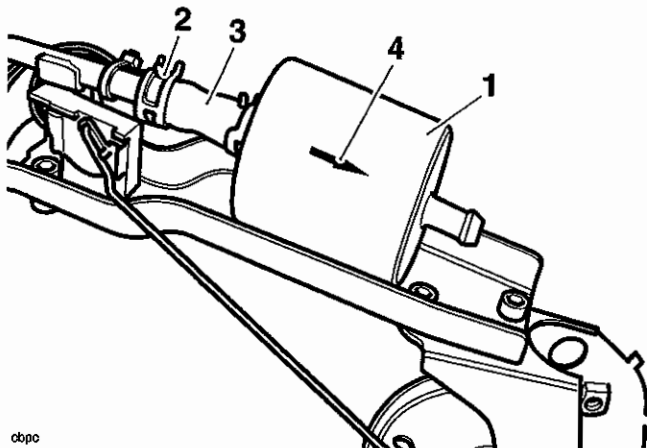

cbpc

1. Filter
2. Clip
3. Inlet hose
4. Filter arrow

7. Position the hose clip to the filter inlet.
8. Refit the pressure regulator and hoses to the filter and pump plate. Engage the hoses with the filter outlet and pump plate.
9. Secure the regulator to the mounting bar with a new screw, tightening it to **10 Nm**.
10. Position the hose clips to the filter outlet and pump plate.

11. Reconnect the two electrical connections to the pump plate, in the positions noted/marked prior to removal.

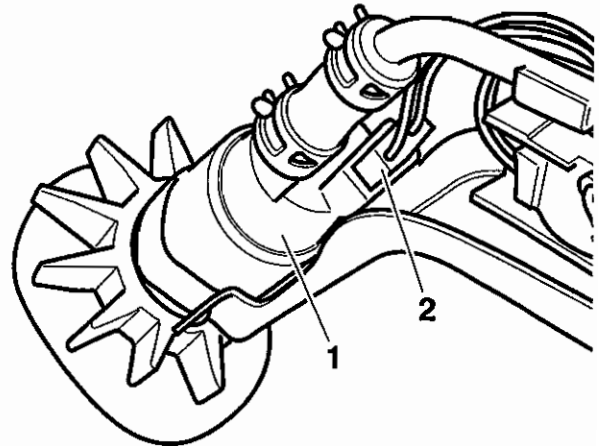

cbpe

1. Fuel pump
2. Electrical connection

12. Check that the fuel level sender arm moves freely along its full range of travel, and comes to rest on the pump plate. Rectify as necessary.

Installation

1. Position a new 'O'-ring seal to the fuel tank opening.
2. Refit the fuel pump assembly to the tank. Fit and tighten the nuts to **5 Nm** working on diagonally opposite nuts to spread the clamping load evenly.
3. Refit the fuel tank as described on page 11.101.

Airbox, Intake Duct and Hoses

Removal

1. Remove the rider's seat as described on page 17.9.
2. Disconnect and remove the battery as described on page 18.9.
3. Remove the fuel tank as described on page 11.100.
4. Remove both side covers as described on page 17.9.
5. Remove the rear wheel as described on page 16.8.
6. Remove the rear mudguard as described on page 17.12.
7. From the left hand side, detach the roll over valve from its clip, then release the two screws that secure the relay pack to the airbox side.

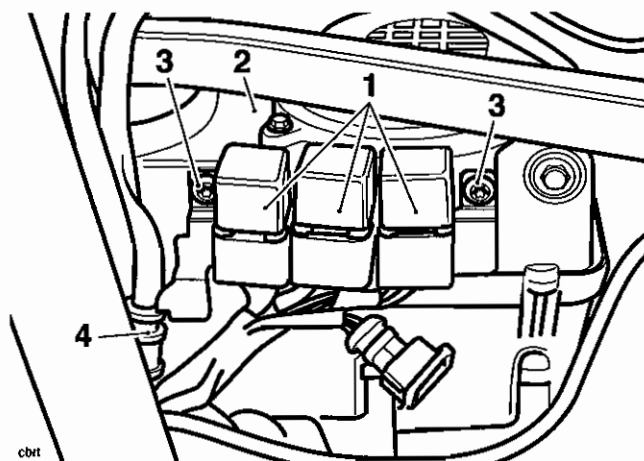

- cbtt
1. Relay pack
 2. Airbox
 3. Screws
 4. Roll-over valve

8. Ease the relay pack from the airbox.

Note:

- It is not necessary to disconnect or remove the relays or disconnect the roll-over valve hoses
9. If an evaporative canister is fitted, cut the cable ties securing it to the airbox.

10. Make a note of (or mark) the hose locations before disconnecting them from the evaporative canister.

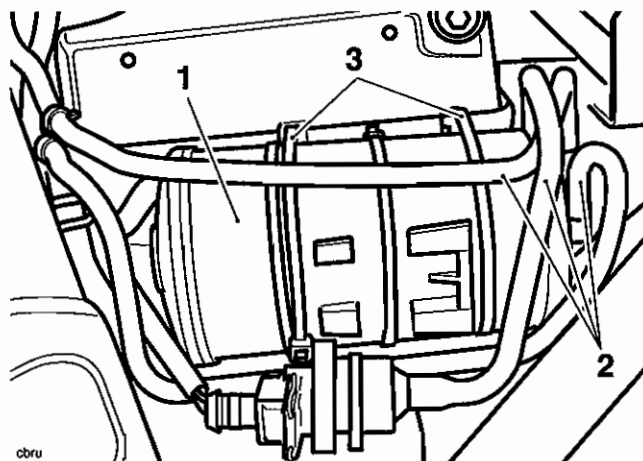

- cbtu
1. Evaporative canister
 2. Hoses
 3. Cable ties

11. Remove the canister.
12. Disconnect the electrical connections to the fall detection switch and alternator rectifier.

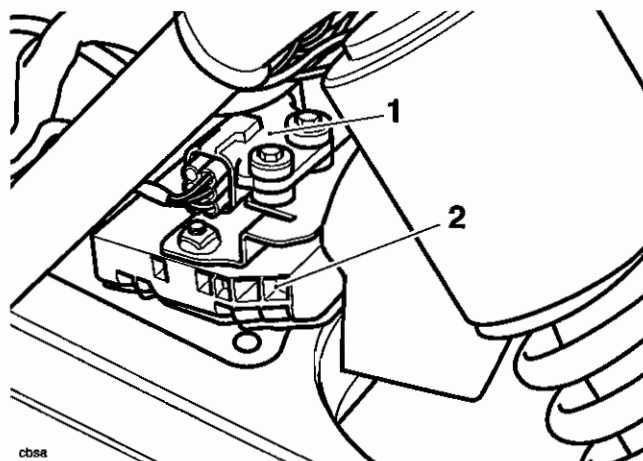

- cbss
1. Fall detection switch
 2. Alternator rectifier

Fuel System/Engine Management

13. Release the fir-tree plugs securing the fuse box to the battery box.

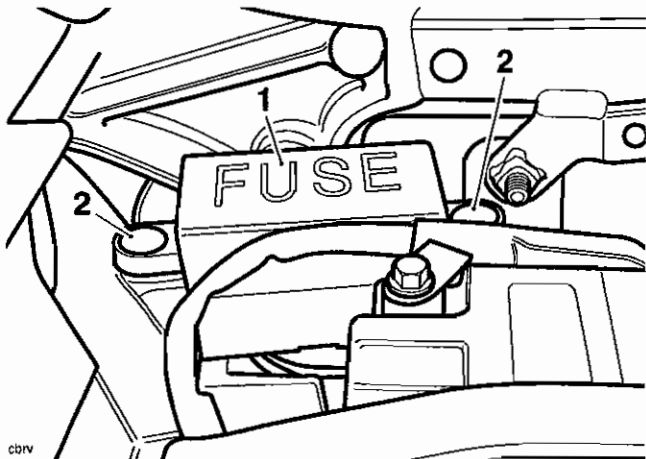

- cbrv
1. Fuse box
2. Fir-tree plugs

14. Manoeuvre the relay pack, fuse box and other electrical connectors aside.

Note:

- Before proceeding, make a note of the cable routings around the ECM and ECM bracket.

15. Working on the right hand side, remove the screws securing the engine management ECM to its bracket.

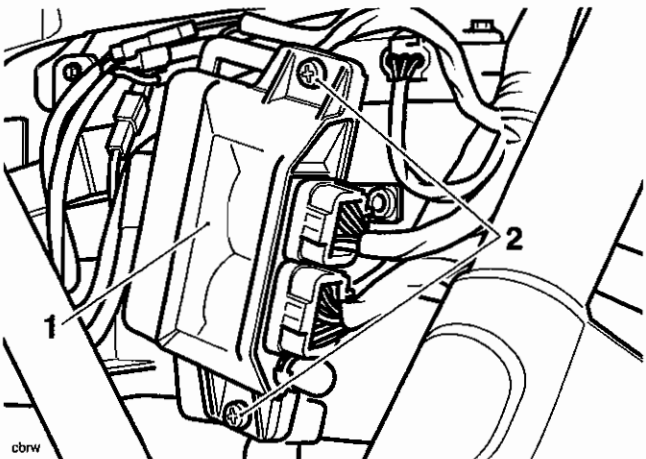

- cbrw
1. ECM
2. Screws

16. Ease the ECM from its bracket then disconnect the two electrical connections.

Electrical connections

17. Place the ECM to one side.

18. Remove the three screws from the ECM bracket, then detach the bracket.

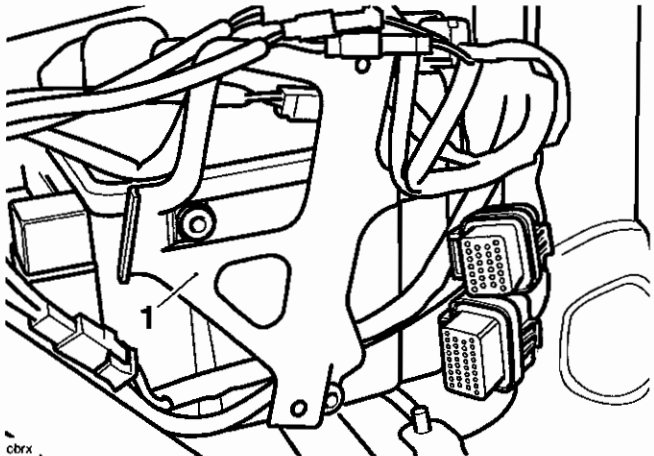

- cbrx
1. ECM bracket

19. Ease the two relay connectors from the battery box by pushing them upwards.

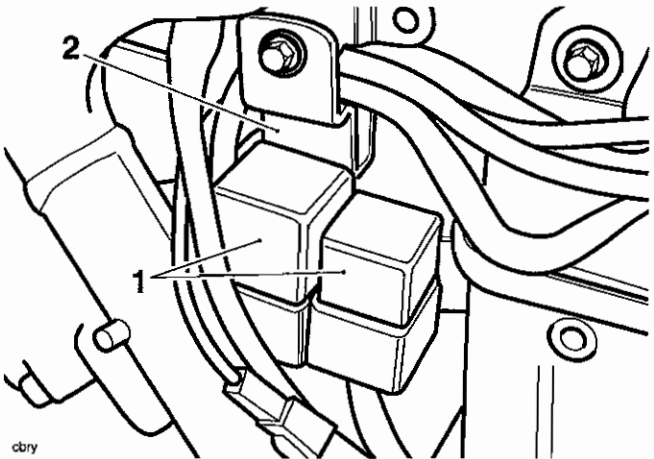

- cby
1. Relays
2. Battery box

20. Disconnect the barometric pressure sensor.

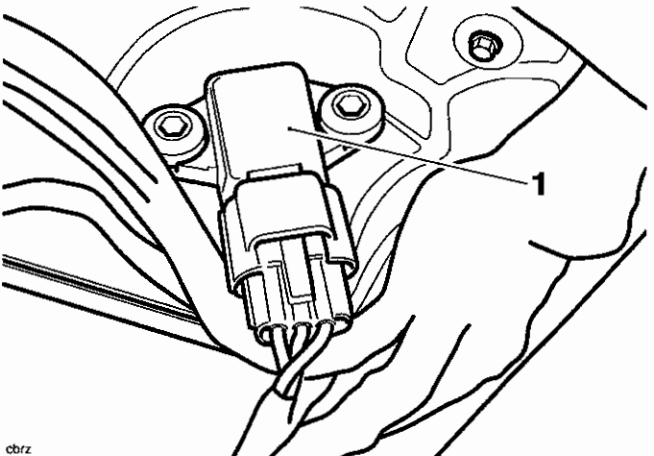

- cbrz
1. Barometric pressure sensor

21. Lay the relays, ECM connectors and other wiring aside.
22. Release the two screws securing the seat lock to the frame, then lay the seat lock (still attached to its cable) to one side.

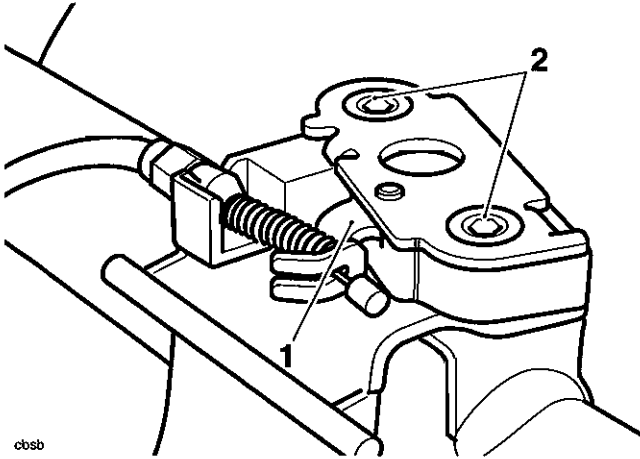

cbssb

1. Seat Lock
2. Screws

23. Release the two screws securing the battery box assembly to the frame.

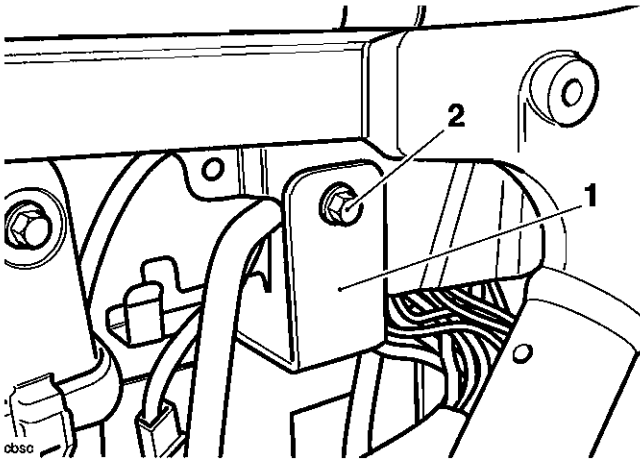

cbssc

1. Battery box
2. Screw (left hand shown)

24. Manoeuvre the battery box assembly from the motorcycle and place aside.

25. Noting their orientation, release the three clips securing the intake plenum to the throttle bodies.

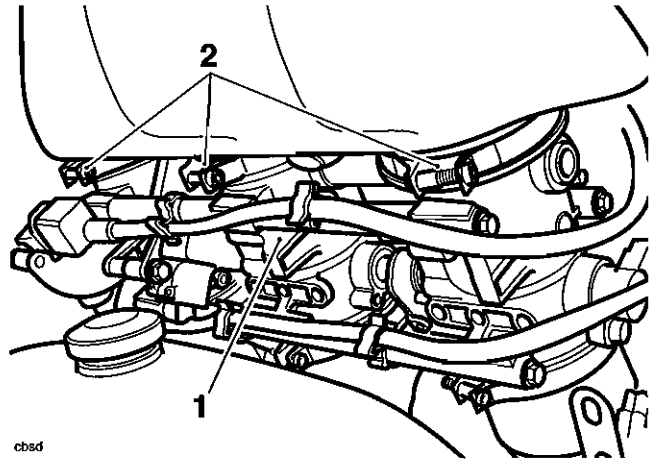

cbssd

1. Throttle bodies
2. Clips

26. Noting their orientation, release the two clips securing the intake plenum to the intake duct.

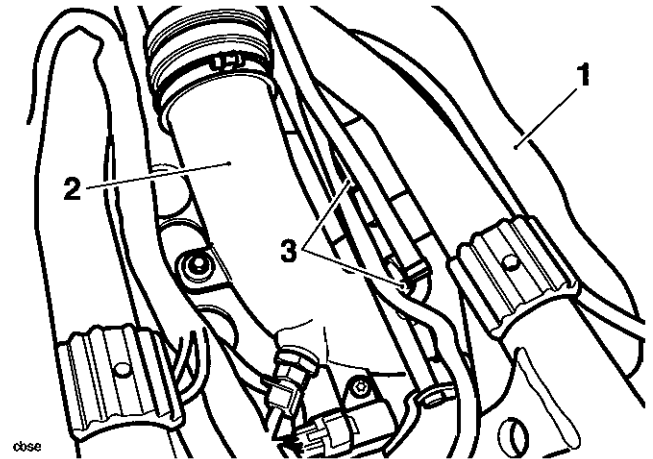

cbssd

1. Intake plenum
2. Intake duct
3. Clips

27. Carefully detach the intake plenum from the throttle bodies and intake duct. Place the intake plenum aside.

Fuel System/Engine Management

28. Release the clip securing the intake hose to the intake duct.

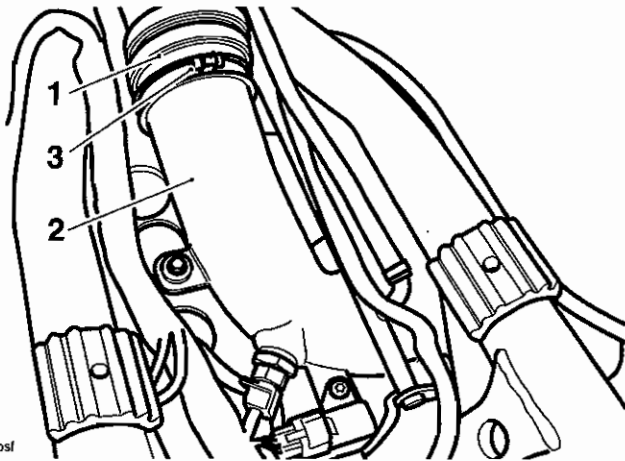

- 1. Intake hose
- 2. Intake duct
- 3. Clip

29. Disconnect the manifold absolute pressure (MAP) and air temperature sensors.

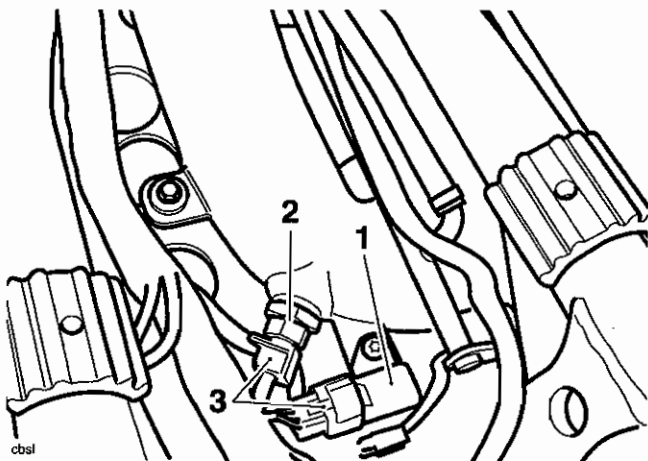

- 1. MAP sensor
- 2. Air temperature sensor
- 3. Connectors

Note:

- Prior to removing the intake duct, the MAP sensor hose must be disconnected.

30. Release the fixing securing the intake duct to its bracket. Remove the duct.

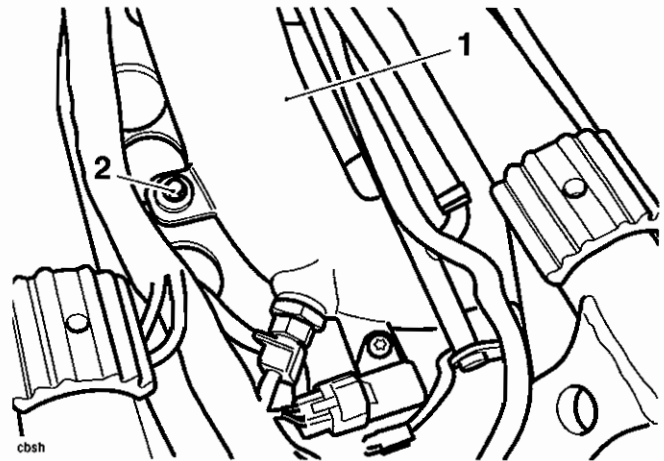

- 1. Intake duct
- 2. Fixing

31. Release the clip securing the intake hose to the airbox.

32. Detach the intake hose and place it aside.

33. Release the clip securing the airbox breather hose to the engine.

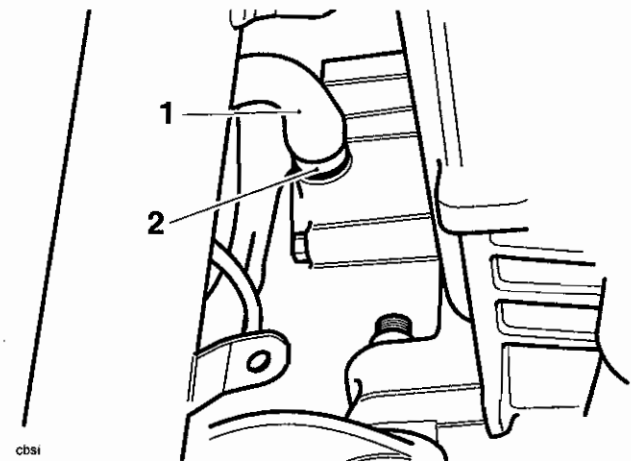

- 1. Breather hose
- 2. Clip

34. Release the two fixings securing the airbox to the frame.

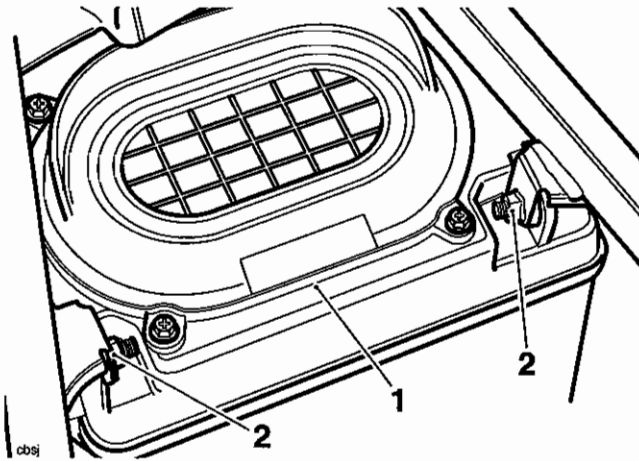

1. Airbox
2. Fixings

35. Manoeuvre the airbox from the frame.

Installation

1. Position the airbox to the frame ensuring the semi circular feature at the front of the airbox is located on the frame cross tube behind the engine. Attach the airbox breather hose to the engine and secure it with the clip before proceeding.

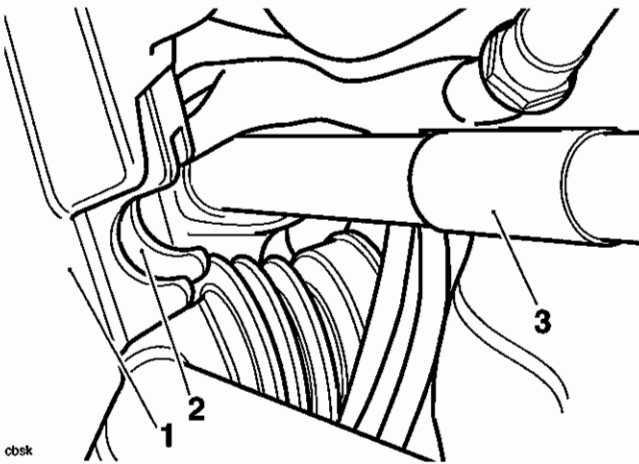

1. Airbox
2. Semi-circular feature
3. Frame cross tube

2. Pivot the airbox upwards at the rear and engage the two bolts that secure it to the frame. Tighten the bolts to **9 Nm**.
3. Refit the intake hose to the airbox and secure it with the clip.

Caution

Ensure the hose is positively located to the airbox and is retained by the clip through its full circumference. Rectify if necessary as poor engine performance and engine damage may result from poor hose sealing.

4. Position the intake duct to its bracket and also to the intake hose. Secure the hose with its clip. Tighten the duct fixing to **9 Nm**.

Caution

Ensure the hose is positively located to the duct and is retained by the clip through its full circumference. Rectify if necessary as poor engine performance and engine damage may result from poor hose sealing.

5. Reconnect the MAP and air temperature sensors.

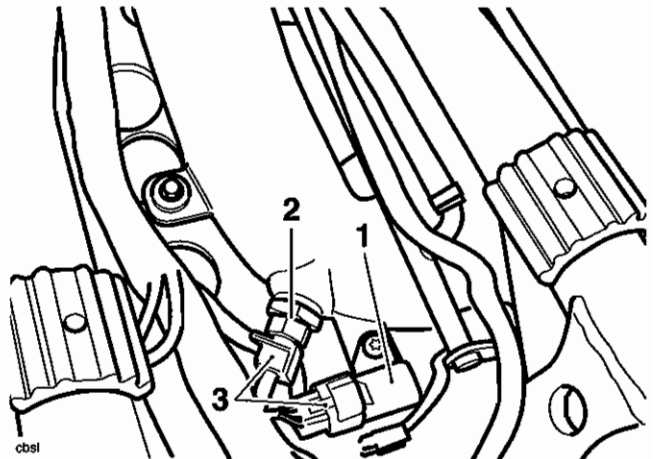

1. MAP sensor
2. Air temperature sensor
3. Connectors

6. Refit the intake plenum to the throttle bodies and intake duct. Tighten all hose clips.

Caution

Ensure the plenum is positively located to the throttle bodies and intake duct and is retained by the clips through their full circumference. Rectify if necessary as poor engine performance and engine damage may result from poor plenum/duct sealing.

7. Position the battery box to the frame.
8. Tighten the battery box fixings to **9 Nm**.
9. Reposition the seat lock to the frame and battery box. Tighten the lock fixings to **5 Nm**.

Fuel System/Engine Management

10. On the right hand side, fit the two relays and sockets to their mounting points on the battery box. Ensure that both relays are fully engage on their mountings.

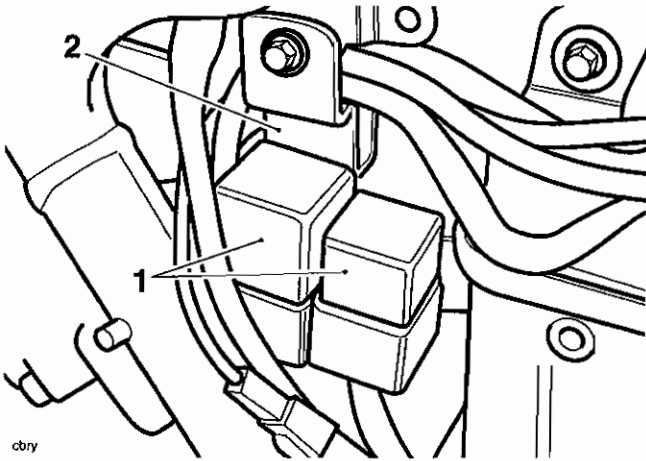

- 1. Relays**
2. Battery box

11. Arranging the cables to the rear of the ECM bracket as noted prior to removal, refit the ECM bracket and tighten its screws to 3 Nm.

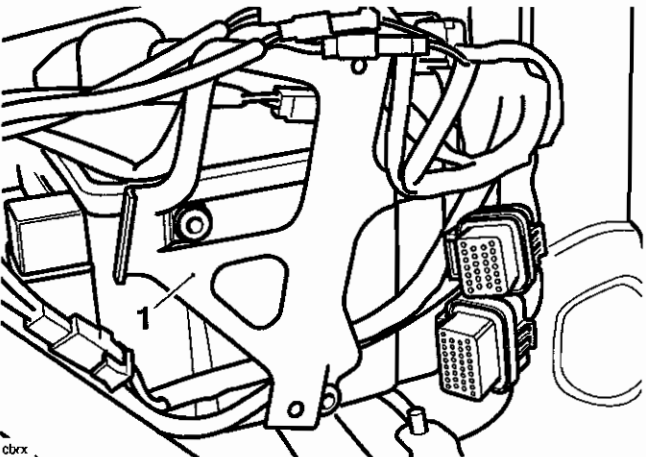

- 1. ECM bracket**
2. Cables

12. Locate the ECM to its bracket and tighten its screws to 3 Nm.
13. Reconnect both multi-plugs to the ECM.

14. Reconnect the barometric pressure sensor.

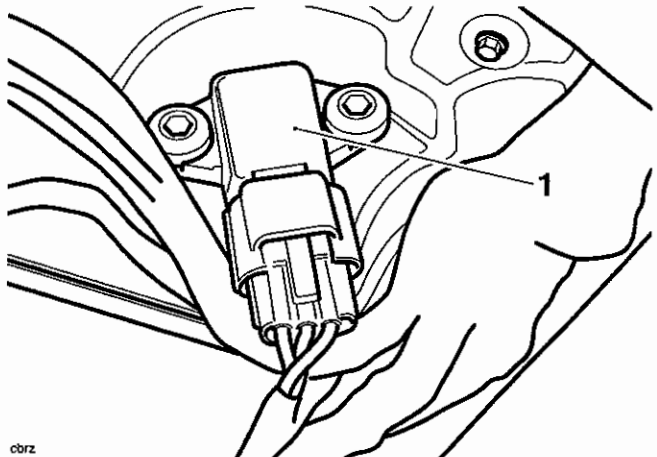

Barometric pressure sensor

15. Working on the left hand side, position the relay pack to the airbox.
16. Fit the relay pack screws and tighten to 3 Nm.

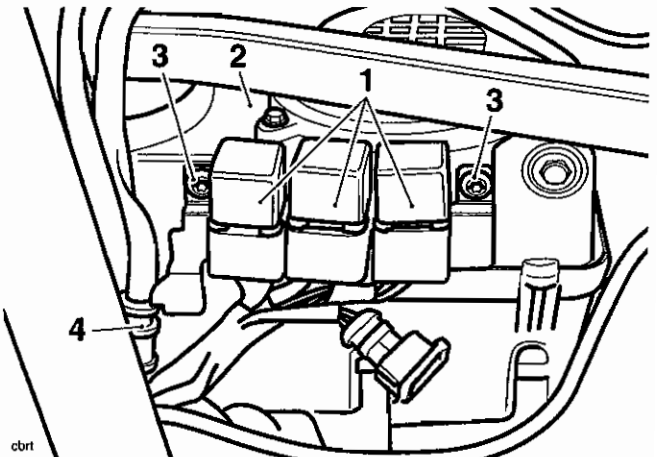

- 1. Relay pack**
2. Airbox
3. Screws
4. Roll-over valve

17. Reattach the roll over valve to its bracket.
18. Position the fuse box to the battery box. Retain the fuse box with new fir-tree plugs.
19. Reconnect the fall detection switch and alternator rectifier.

- If fitted, position and secure the evaporative canister to the airbox using new cable-ties. Reattach the hoses to the canister ensuring they are fitted in the positions noted during strip-down.

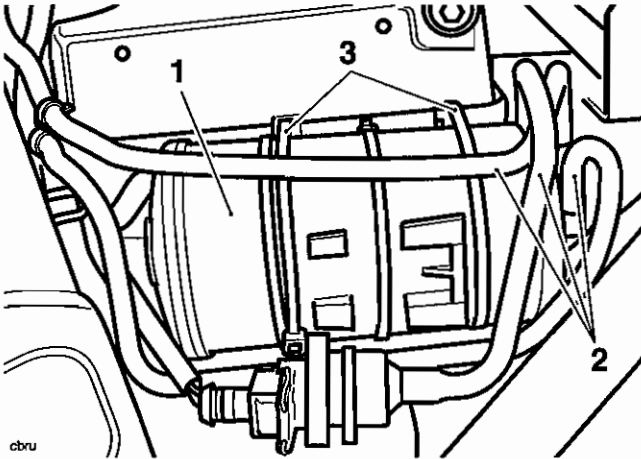

cbvu

- Evaporative canister
- Hoses
- Cable ties

- Refit the rear mudguard as described on page 17.13.
- Refit the rear wheel as described on page 16.9.
- Refit and reconnect the battery as described on page 18.10.
- Refit both side covers as described on page 17.9.
- Refit the fuel tank as described on page 11.101.
- Refit the rider's seat as described on page 17.9.

Air Filter

Removal

- Remove the rider's seat as described on page 17.9.
- Disconnect the battery negative (black) lead first.
- Pivot the tool kit upwards to gain access to the top of the air box.
- Release the four screws securing the air filter cover to the airbox.

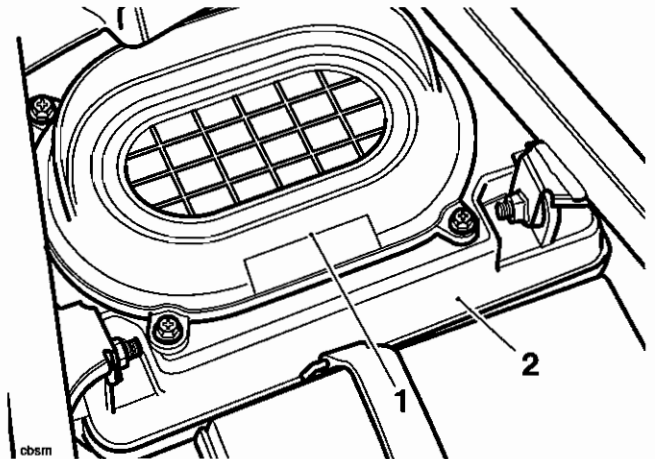

cbsm

- Air filter cover
- Airbox

- Raise the filter cover to detach the air filter element from the housing.

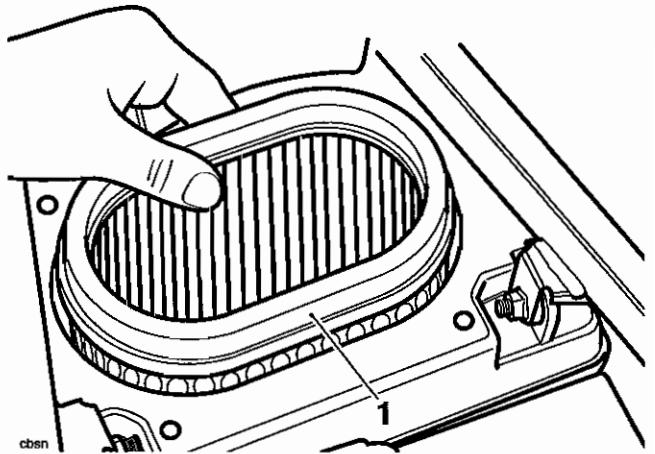

cbsm

- Filter element

- Inspect the cover seal for damage.

Assembly

1. Clean the air filter cover and interior of the airbox.
2. Locate the new filter element to the airbox.
3. Refit (or replace if necessary) the cover seal, fit the filter cover and tighten the screws to **3 Nm**.
4. Reconnect the battery, positive (red) lead first.
5. Place the tool kit in its installed position on the frame.
6. Refit the rider's seat as described on page 17.9.

Intake Air Temperature Sensor

Removal

1. Remove the rider's seat as described on page 17.9.
2. Disconnect the battery negative (black) lead first.
3. Raise and prop the fuel tank as described on page 11.98.
4. Disconnect the electrical multi-plug from the sensor.

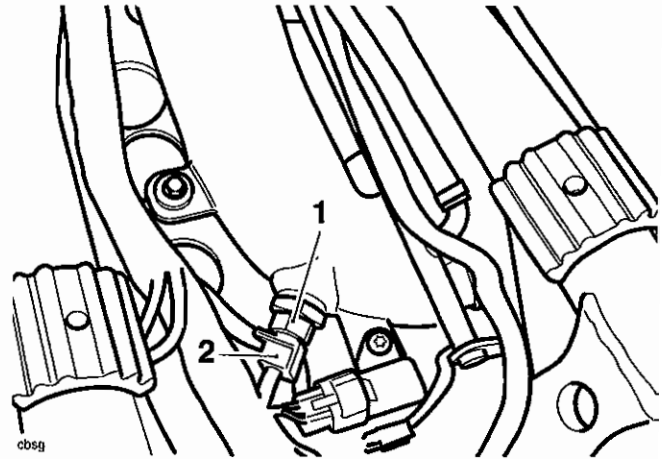

1. Air temperature sensor
2. Multi-plug

5. Unscrew the sensor from the intake duct.

Installation

1. Fit the sensor to the intake duct and tighten to **3 Nm**.
2. Reconnect the multi-plug.
3. Support the tank, remove and stow the tank prop, then lower the tank to the frame and secure it as described on page 11.99.
4. Reconnect the battery, positive (red) lead first.
5. Refit the rider's seat as described on page 17.9.

Manifold Absolute Pressure (Map) Sensor

Removal

1. Remove the rider's seat as described on page 17.9.
2. Disconnect the battery negative (black) lead first.
3. Raise and prop the fuel tank as described on page 11.98.
4. Disconnect the electrical multi-plug from the sensor.

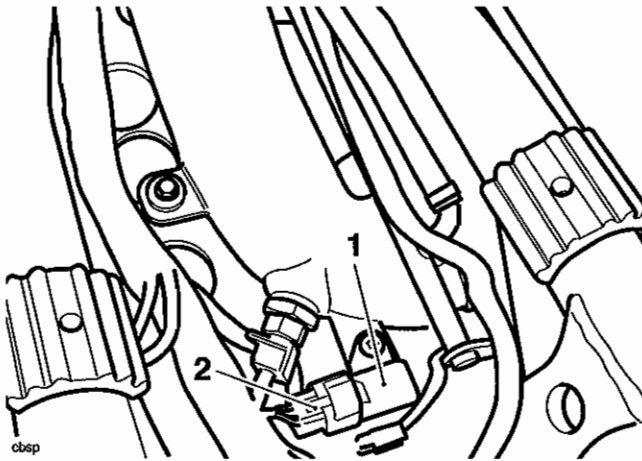

cbasp
1. MAP sensor
2. Multi-plug

5. Unscrew the bolt securing the sensor to the intake duct.
6. Raise the sensor in order to disconnect the hose from below it.

Installation

1. Fit the sensor to the intake duct, reconnect the hose and tighten the bolt to **3 Nm**.
2. Reconnect the multi-plug.
3. Support the tank, remove and stow the tank prop, then lower the tank to the frame and secure it as described on page 11.99.
4. Reconnect the battery, positive (red) lead first.
5. Refit the rider's seat as described on page 17.9.

Barometric Pressure Sensor

Removal

1. Remove the rider's seat as described on page 17.9.
2. Disconnect the battery negative (black) lead first.
3. Remove the right hand side cover as described on page 17.9.
4. Disconnect the electrical multi-plug from the sensor.

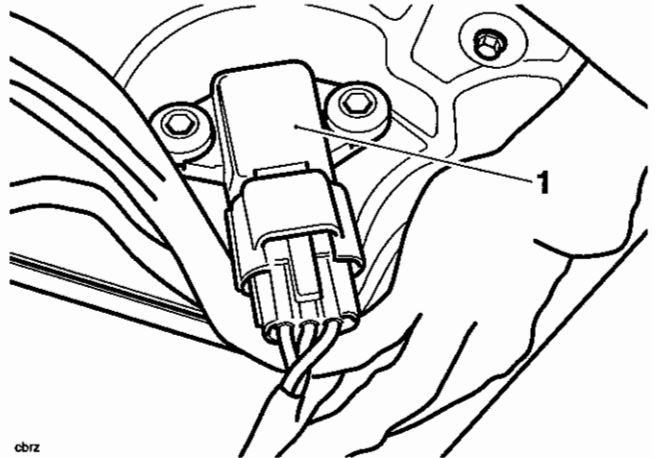

cbbrz

1. Barometric pressure sensor
2. Multi-plug

5. Release the two screws securing the sensor to the airbox.
6. Raise the sensor to remove it from the airbox and collect the O-ring.

Installation

1. Take a new O-ring and lubricate it with a smear of petroleum jelly. Fit the O-ring to the sensor, then fit the sensor to the airbox, tightening the two screws to **3 Nm**.
2. Reconnect the multi-plug.
3. Refit the right hand side cover as described on page 17.9.
4. Reconnect the battery, positive (red) lead first.
5. Refit the rider's seat as described on page 17.9.

Gear Position Sensor

Removal

1. Remove the rider's seat as described on page 17.9.
2. Disconnect the battery negative (black) lead first.
3. Remove the engine infill panel from the left hand side of the engine (see page 17.10).

Note:

- Behind the engine infill panel, secured by the same fixings as the panel, is a connector support bracket. The gear position sensor plug is located here.
4. Release the two screws securing the sensor to the rear of the engine, on the left hand side.

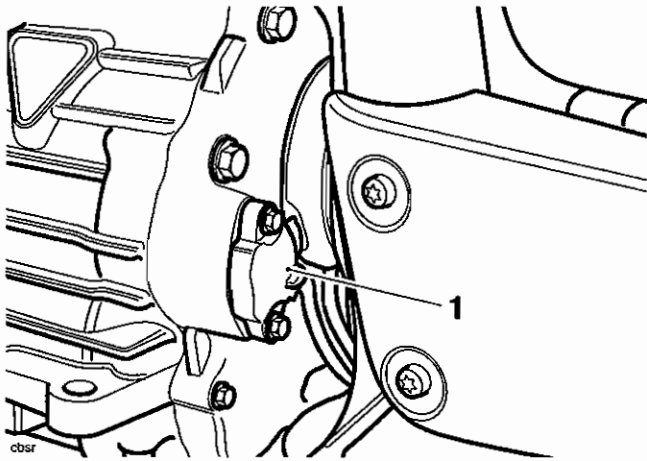

1. Gear position sensor

5. Ease the connector rearwards to detach it from the engine. Recover and discard the O-ring that seals the sensor to the engine.

Note:

- Make a note of the sensor's wiring run in order to return it to the same routing on assembly.
6. Trace the connector wiring back to the connector. Disconnect the sensor and detach it from the motorcycle.

Installation

1. Fit a new O-ring to the sensor. Lubricate the O-ring with a smear of petroleum jelly.
2. Position the sensor to the engine and route the wiring as noted prior to removal.
3. Retain the sensor with the two screws, tightening them to **9 Nm**.
4. Connect the sensor to the main wiring harness. Reattach the connector to the bracket.
5. Position the left hand engine infill panel to the frame. Align the screw holes in the panel with those in the connector bracket and frame. Fit and tighten the screws to **3 Nm**.
6. Reconnect the battery, positive (red) lead first.
7. Refit the rider's seat as described on page 17.9.

Road Speed Sensor

Removal

1. Remove the rider's seat as described on page 17.9.
2. Disconnect the battery negative (black) lead first.
3. Remove the engine infill panel from the left hand side of the engine (see page 17.10).

Note:

- **Behind the engine infill panel, secured by the same fixings as the panel, is a connector support bracket. The road speed sensor plug is located here.**
4. Release the screw securing the sensor to the bottom of the engine, on the left hand side.

Installation

1. Fit a new O-ring to the sensor. Lubricate the O-ring with a smear of petroleum jelly.
2. Position the sensor to the engine and route the wiring as noted prior to removal.
3. Retain the sensor with the screw then tighten the screw to **9 Nm**.
4. Connect the sensor to the main wiring harness. Reattach the connector to the bracket.
5. Position the left hand engine infill panel to the frame. Align the screw holes in the panel with those in the connector bracket and frame. Fit the screws and tighten to **3 Nm**.
6. Reconnect the battery, positive (red) lead first.
7. Refit the rider's seat as described on page 17.9.

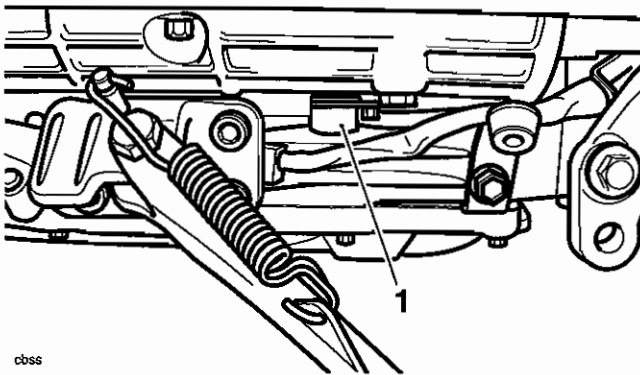

cbss

1. Road speed sensor

5. Ease the sensor downwards to detach it from the engine. Recover the O-ring that seals the sensor to the engine (the O-ring is normally retained by the sensor).

Note:

- **Make a note of the sensor's wiring run in order to return it to the same routing on assembly.**
6. Trace the connector wiring back to the connector. Disconnect the sensor and detach it from the motorcycle.

Crankshaft Position Sensor

Removal

1. Remove the rider's seat as described on page 17.9.
2. Disconnect the battery negative (black) lead first.
3. Remove the engine infill panel from the left hand side of the engine (see page 17.10).

Note:

- Behind the engine infill panel, secured by the same fixings as the panel, is a connector support bracket. The road speed sensor plug is located here.
4. Release the screw securing the sensor to the bottom of the alternator cover.

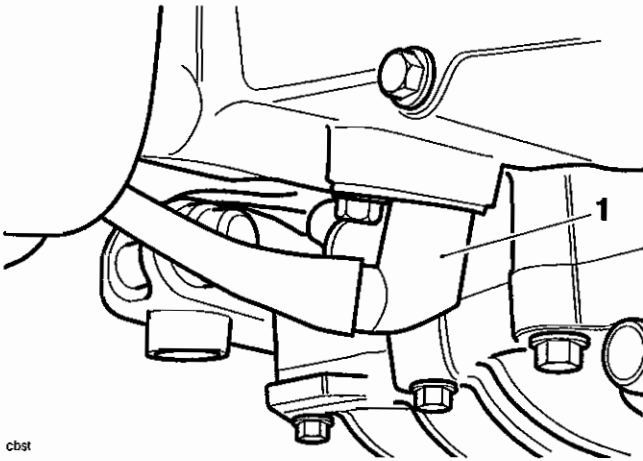

cbst

1. Crankshaft position sensor

5. Ease the sensor downwards to detach it from the engine. Recover and discard the O-ring.

Note:

- Make a note of the sensor's wiring run in order to return it to the same routing on assembly.
6. Trace the connector wiring back to the connector. Disconnect the sensor and detach it from the motorcycle.

Installation

1. Fit a new O-ring to the sensor. Lubricate the O-ring with a smear of petroleum jelly.
2. Position the sensor to the engine and route the wiring as noted prior to removal.
3. Retain the sensor with the screw, tightening it to **9 Nm**.

Note:

- The air gap for the crankshaft position sensor is not adjustable.
4. Connect the sensor to the main wiring harness. Reattach the connector to the bracket.
 5. Position the left hand engine infill panel to the frame. Align the screw holes in the panel with those in the connector bracket and frame. Fit the screws and tighten to **3 Nm**.
 6. Reconnect the battery, positive (red) lead first.
 7. Refit the rider's seat as described on page 17.9.

Throttle Cables



The throttle grip controls the throttle valves in the throttle bodies. If the throttle cables are incorrectly adjusted, either too tight or too loose, the throttle may be difficult to control and performance will be adversely affected.

Check the throttle grip free-play in accordance with scheduled maintenance requirements and make adjustments as necessary.

Always be alert for changes in the 'feel' of the throttle and have the throttle system checked by an authorised Triumph dealer if any changes are detected. Changes can be due to wear in the mechanism, which could lead to a sticking throttle.

An incorrectly adjusted, sticking or stuck throttle will lead to loss of motorcycle control and an accident.

Removal

Note:

- Prior to removal, clearly identify the opening and closing cables so that they may be refitted in the correct positions.

1. Remove the rider's seat.
2. Disconnect the battery negative (black) lead first.
3. Raise and prop the fuel tank as described on page 11.98.
4. Remove the intake cover as described on page 11.98.
5. Remove the headstock cover.
6. Slacken the adjuster locknuts at the throttle body such that they will allow the outer cables to be detached from the cable brackets.

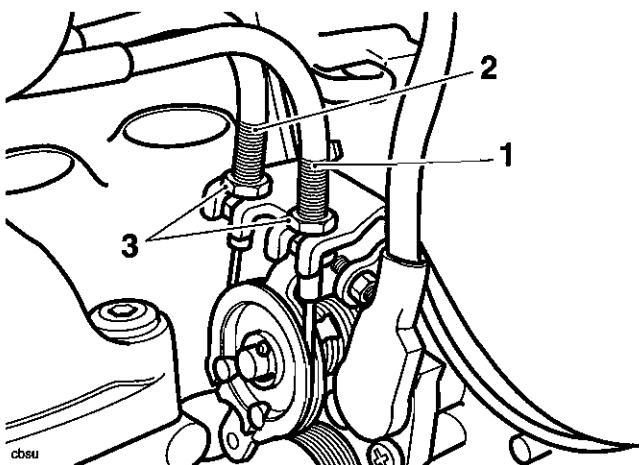

1. Opening cable adjuster
2. Closing cable adjuster
3. Locknuts

7. Detach the inner cables from the throttle cam.
8. At the twist grip end, remove the screws securing the right hand switch cube to the brake master cylinder.

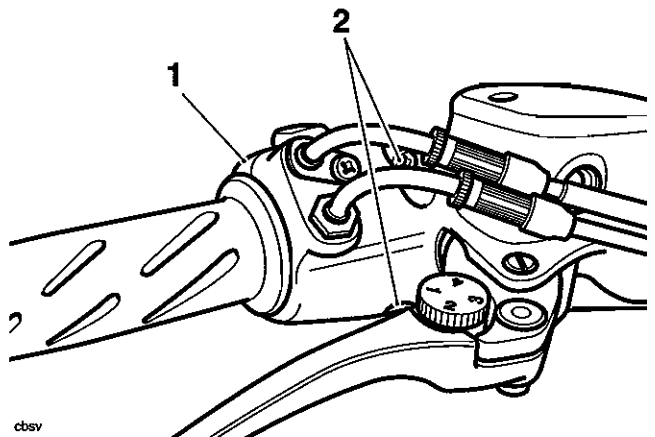

cbsv

1. Right hand switch cube
2. Screws

9. Separate the switch cube from the master cylinder.
10. Release the screw and union securing the throttle cables to the master cylinder.

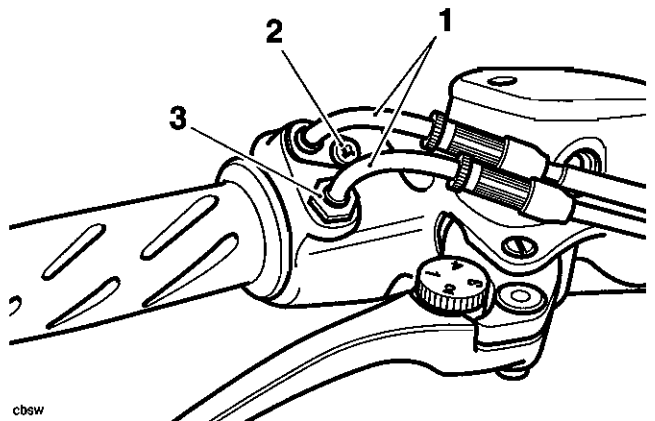

cbsw

1. Throttle cables
2. Screw
3. Union

Fuel System/Engine Management

11. Release, but do not remove completely, the two screws securing the master cylinder to the handlebar.

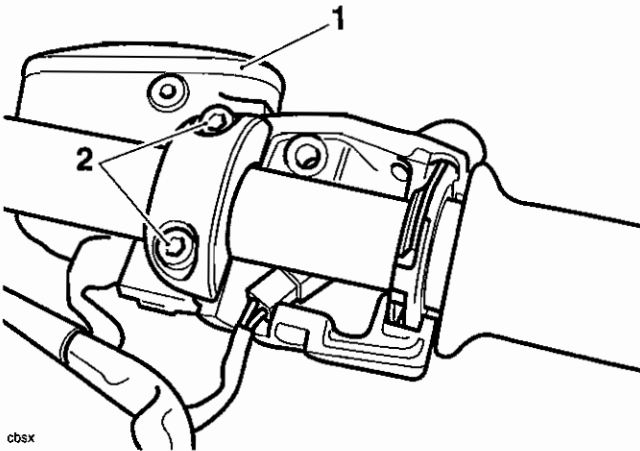

- obsx
1. Master cylinder
 2. Screws

12. Ease the master cylinder away from the handlebar to allow space for the throttle cables to be detached from the twist grip. Detach the cables from the twist grip.

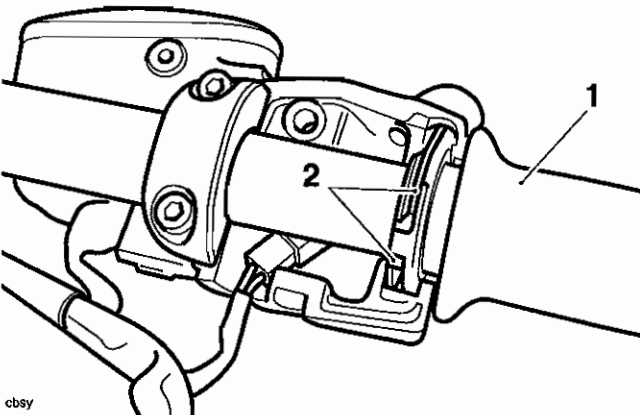

- obsy
1. Twist grip
 2. Throttle cables

13. Note the routing of the throttle cables, then remove them from the frame.

Examination

1. Check that the throttle cables operate smoothly, without sticking or binding. Replace the cable if there is any doubt as to its correct operation.

Installation

Note:

- The opening and closing cables must be correctly identified and fitted to the correct positions as noted prior to removal.

1. Locate the cables to the frame following the routing noted during removal.
2. Engage the nipples of the inner cables to the twist grip.
3. Locate the master cylinder to the handlebars.
4. Position the clamp to the rear side of the handlebars.
5. Align the master cylinder/clamp split line with the dot mark on the underside of the handlebar.

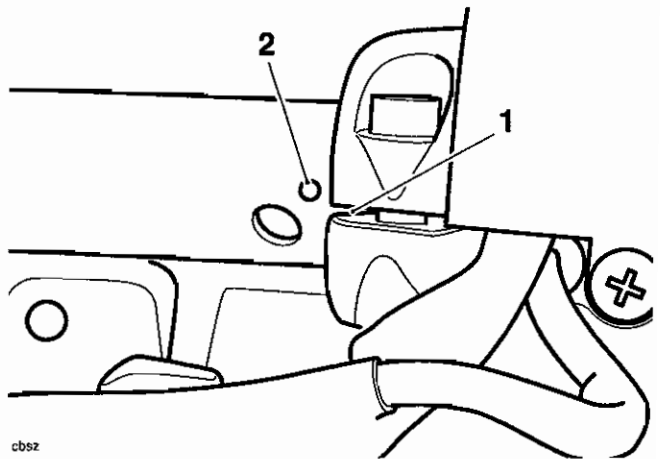

- obsz
1. Split line
 2. Dot mark

6. Tighten the master cylinder clamp bolts, upper first and then the lower to **15 Nm**.
7. Assemble the switch cube to the master cylinder, tightening the two screws to **4 Nm**.
8. Attach the cable retainer screw and union to the master cylinder, tightening both to **3 Nm**.

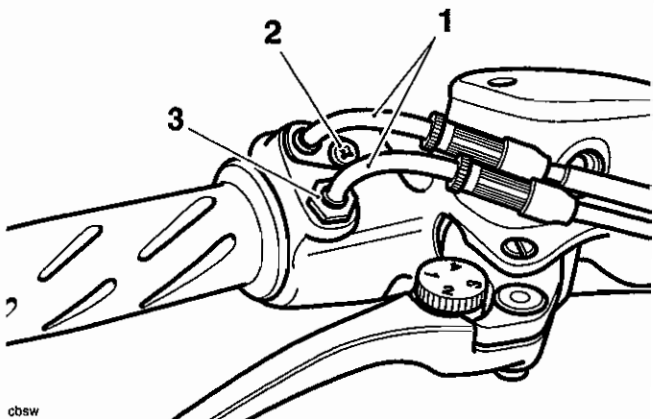

- obsx
1. Throttle cables
 2. Retainer screw
 3. Union

- Attach the other end of the inner cables to the throttle cam and locate the outer cables to the cable bracket. Ensure the opening and closing cables are located to the correct cams then fit the cable locknuts.

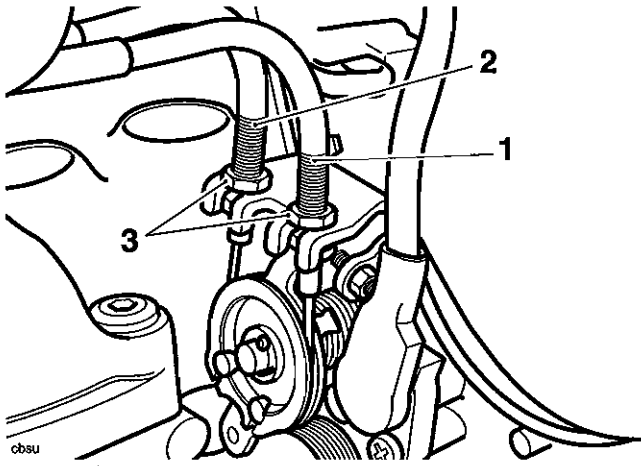

- obsu
- Opening cable adjuster
 - Closing cable adjuster
 - Locknuts

Throttle cable adjustment

- When correctly set, the throttle must have 2-3 mm of free-play at the throttle twist grip. If there is more or less than 2-3 mm of free-play present, the throttle cables must be adjusted.

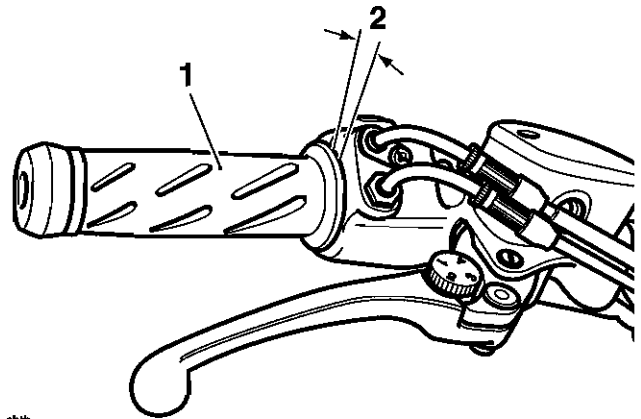

- obib
- Throttle twist grip
 - 2-3 mm

If there is an incorrect amount of free-play, adjustment may be made as follows:

Warning

Operation of the motorcycle with an incorrectly adjusted, incorrectly routed or damaged throttle cable could interfere with the operation of the brakes, clutch or the throttle itself. Any of these conditions could result in loss of control of the motorcycle and an accident.

Warning

Move the handlebars to left and right full lock while checking that cables and harnesses do not bind. A cable or harness that binds will restrict the steering and may cause loss of control and an accident.

Warning

Use of the motorcycle with incorrectly adjusted, incorrectly routed, sticking or damaged throttle cables will interfere with the throttle function resulting in loss of motorcycle control and an accident.

To avoid incorrect adjustment, incorrect routing, or continued use of a sticking or damaged throttle, always have your throttle checked and adjusted by your authorised Triumph dealer.

- Refit the headstock cover.
- Support the tank, remove and stow the tank prop, then lower the tank to the frame and secure it as described on page 11.99.
- Refit the intake cover (see page 11.99).
- Reconnect the battery, positive (red) lead first.
- Refit the rider's seat as described on page 17.9.
- Set the cable adjustment using the adjustment instructions that follow:

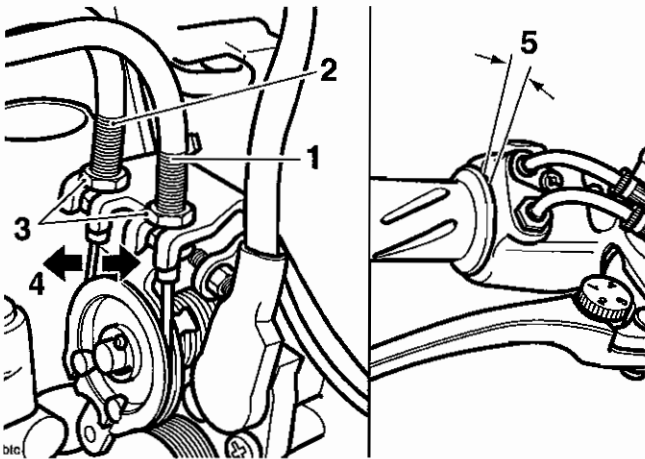

1. Opening cable adjuster
2. Closing cable adjuster
3. Locknuts

4. Closing cable - free play measurement point
5. Opening cable - free play measurement point

2. Remove the intake and headstock covers if not already removed.
3. Release the locknut on the 'opening' cable adjuster.
4. Rotate the 'opening' cable adjuster at the twist grip end such that it has an equal amount of adjustment in each direction.
5. Rotate the 'opening' cable adjuster at the throttle body end of the cable to give 2-3 mm of play at the twist grip. Tighten the locknut.
6. Make any minor adjustments as necessary to give 2-3 mm of play using the adjuster near the twist grip end of the cable. Tighten the locknut.
7. With the throttle fully closed, ensure that there is 2-3mm of free play in the 'closing' cable at the throttle cam attached to the throttle bodies. If necessary, adjust in the same way as the 'opening' cable until 2-3 mm of play is present.

Warning

Ensure that all the adjuster locknuts of both cables are tightened, as a loose locknut could result in a sticking throttle.

An incorrectly adjusted, sticking or stuck throttle can lead to loss of motorcycle control and an accident.

8. Refit the intake cover, tightening the screws to **9 Nm**.
9. Check that the throttle opens smoothly, without undue force and that it closes without sticking. Rectify as necessary.

Warning

Operation of the motorcycle with an incorrectly adjusted, incorrectly routed or damaged throttle cable could interfere with the operation of the brakes, clutch or the throttle itself. Any of these conditions could result in loss of control of the motorcycle and an accident.

Warning

Move the handlebars to left and right full lock while checking that cables and harnesses do not bind. A cable or harness that binds will restrict the steering and may cause loss of control and an accident.

Throttle Body Balancing

Note:

- Rocket III throttles cannot be balanced using equipment to measure vacuum in each throttle. Instead, the Triumph diagnostic tool must be used.
1. Remove the intake cover as described on page 11.98 to allow access to the adjuster screws.
 2. Connect the diagnostic tool, start the engine and navigate to 'ADJUSTMENTS' as described in section 11.24.
 3. Select 'balance throttles'.

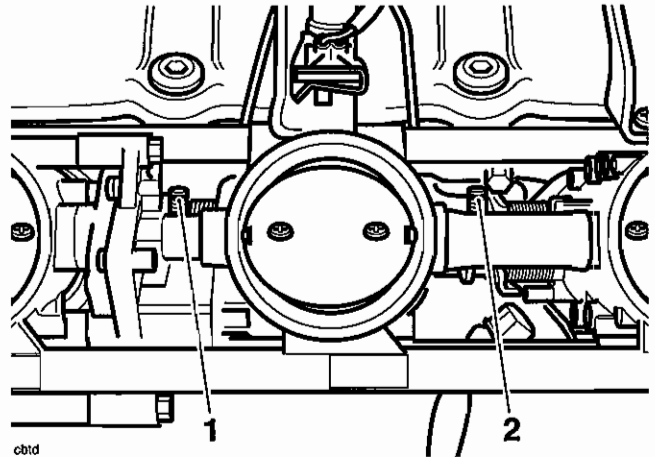

cbtd

1. Adjuster 1

2. Adjuster 2

5. When balanced, stop the engine, disconnect the diagnostic tool and refit the intake cover as described on page 11.99.

| T | H | R | O | T | T | L | E | S | | B | A | L | A | N | C | E | D | | |
|---|---|---|---|---|---|---|---|---|---|---|---|---|---|---|---|---|---|---|---|
| T | H | R | O | T | T | L | E | | 1 | | 1 | 2 | 3 | 4 | ∞ | ∞ | / | H | G |
| T | H | R | O | T | T | L | E | | 2 | | 1 | 2 | 3 | 4 | ∞ | ∞ | / | H | G |
| T | H | R | O | T | T | L | E | | 3 | | 1 | 2 | 3 | 4 | ∞ | ∞ | / | H | G |

Balance throttles screen

Note:

- The balance throttle screens show the vacuum value of each throttle in mm/hg. In addition, when the throttles are balanced to an acceptable range of each other, the word 'balanced' will appear in the top right hand corner of the screen. At this point, no further adjustment is necessary or productive.
4. Remove the intake plenum chamber (see page 11.107) and make adjustments until the word 'BALANCED' appears in the top right hand corner of the screen. Adjusters are located on each throttle as shown in the diagram below.

Fuel System/Engine Management

Throttle Body

Removal

1. Remove the rider's seat
2. Disconnect the battery negative (black) lead first.
3. Raise and prop the fuel tank as described on page 11.98.
4. Noting their orientation, release the three clips securing the intake plenum to the throttle bodies.

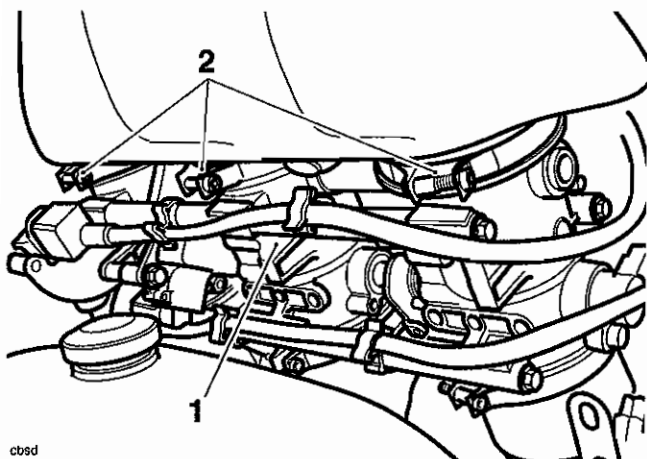

cbst

1. Throttle bodies
2. Clips

5. Release the two clips securing the intake plenum to the intake duct.

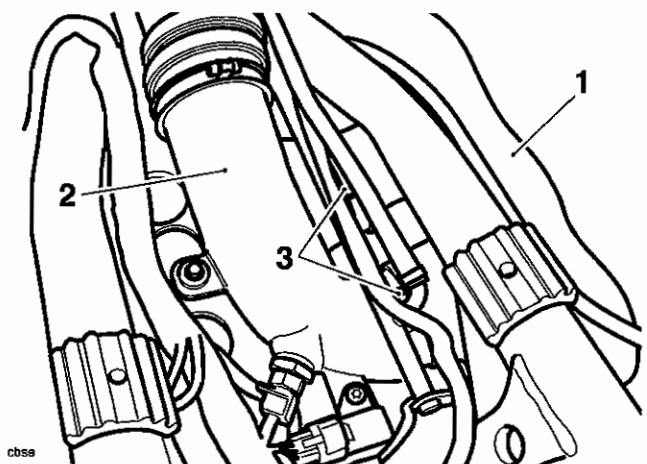

cbss

1. Intake plenum
2. Intake duct
3. Clips

6. Carefully detach the intake plenum from the throttle bodies and intake duct. Place the intake plenum aside.

7. Noting its orientation, release the clip securing the intake hose to the intake duct.

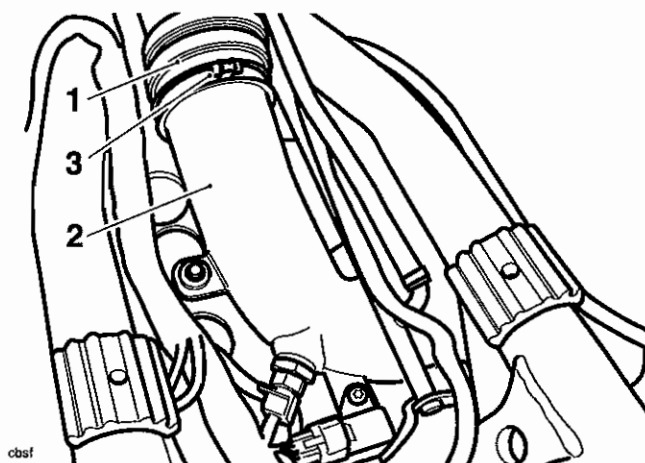

cbst

1. Intake hose
2. Intake duct
3. Clip

8. Disconnect the manifold absolute pressure (MAP) and air temperature sensors from the wiring harness.

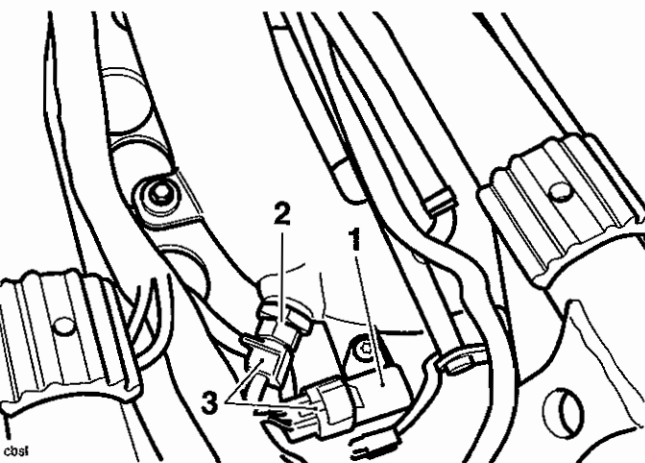

cbst

1. MAP sensor
2. Air temperature sensor
3. Connectors

- Release the fixing securing the intake duct to its bracket. Remove the duct.

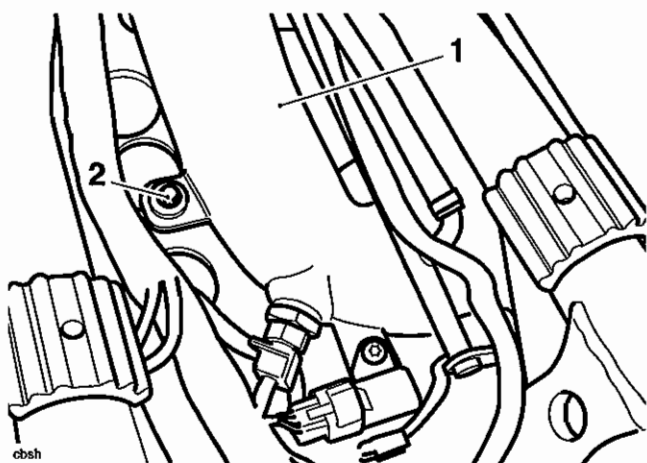

1. Intake duct
2. Fixing

- If fitted, disconnect the small diameter evaporative system return tubes from the base of each throttle.
- Disconnect throttle cables from throttle linkage as described on page 11.117.
- Disconnect the electrical multi-plugs from;
 - both of the throttle position sensors,
 - the idle speed control stepper motor,
 - the second throttle stepper motor,
 - the injectors.
- Detach the MAP sensor hoses from the four-way connector above the cam cover.
- Release the two fixings securing the throttle bodies to the transition piece brackets.
- Release the clips securing the throttle bodies to the transition pieces.

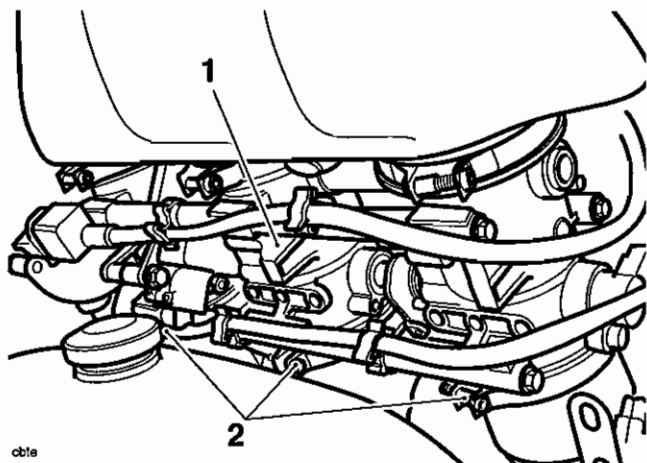

1. Throttle body
2. Clips

- Raise the throttle bodies from the transition pieces and, feeding the fuel hose and wiring past the frame etc. remove the throttle bodies from the engine.
- Remove the screws securing each transition piece to the cylinder head.
- Remove the transition pieces and discard the 'O'-ring seals.

Note:

- Collect the throttle body brackets from the transition pieces for throttles 1 and 3.
- Cover the inlet ports to prevent the ingress of dirt and other objects.

Installation

- Remove the covers from the inlet ports and ensure that the mating faces are clean.
- Locate new 'O'-ring seals to the transition pieces.

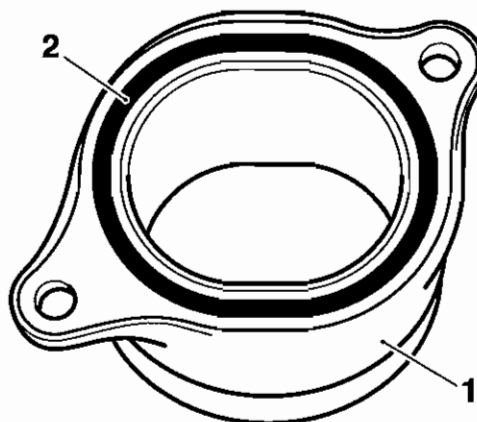

ccam

1. Transition piece
2. O-ring

- Position each transition piece to the cylinder head, together with the brackets on cylinders 1 and 3. Tighten the screws to **12 Nm**.
- Position the throttle body assembly to the transition pieces, feeding the MAP sensor hoses, fuel hoses and sensor/motor cables through the frame. Push each throttle body into its respective transition piece. Ensure that each throttle body is fully seated.
- Tighten the throttle body clips, with the screw heads all facing rearwards, to **1.5 Nm**.

Note:

- Ensure the throttles seat correctly in the transition pieces and seal each throttle through 360 degrees.
- Fit the throttle body to transition piece bracket fixings, tightening them to **6 Nm**.

Fuel System/Engine Management

7. On California models, reconnect the evaporative return hoses to each throttle body.
8. Connect the multi-plugs to;
 - both of the throttle position sensors,
 - the idle speed control stepper motor,
 - the second throttle stepper motor,
 - each injector.
9. Connect and adjust the throttle cables as described on page 11.118.

Warning

Ensure that all the adjuster locknuts of both cables are correctly seated and tightened as a sticking throttle could result from a loose locknut.

An incorrectly adjusted, sticking or stuck throttle will lead to loss of motorcycle control and an accident.

Warning

Operation of the motorcycle with an incorrectly adjusted, incorrectly routed or damaged throttle cable could interfere with the operation of the brakes, clutch or the throttle itself. Any of these conditions could result in loss of control of the motorcycle and an accident.

Warning

Move the handlebars to left and right full lock while checking that cables and harnesses do not bind. A cable or harness that binds will restrict the steering and may cause loss of control and an accident.

10. Feed the MAP sensor hoses back to the four-way connector and reconnect them.
11. Position the intake duct to its bracket and also to the intake hose. Secure the intake hose with its clip.

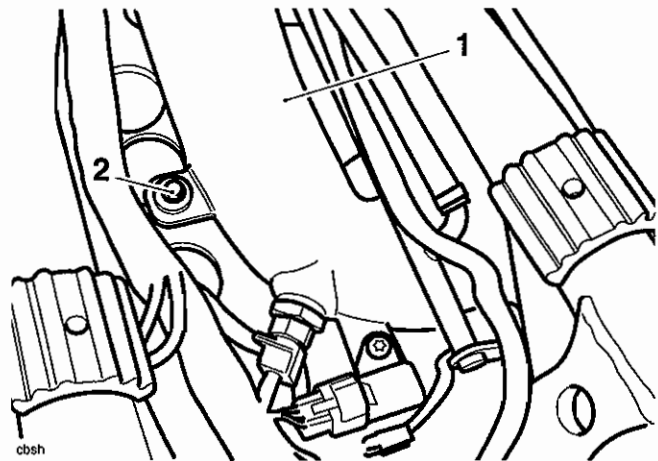

- cbsh
1. Intake duct
 2. Fixing

Caution

Ensure the hose is positively located to the duct and is retained by the clip through its full circumference. Rectify if necessary as poor engine performance and damage may result from poor hose sealing.

12. Refit the intake plenum to the throttle bodies and intake duct. Tighten all hose clips.

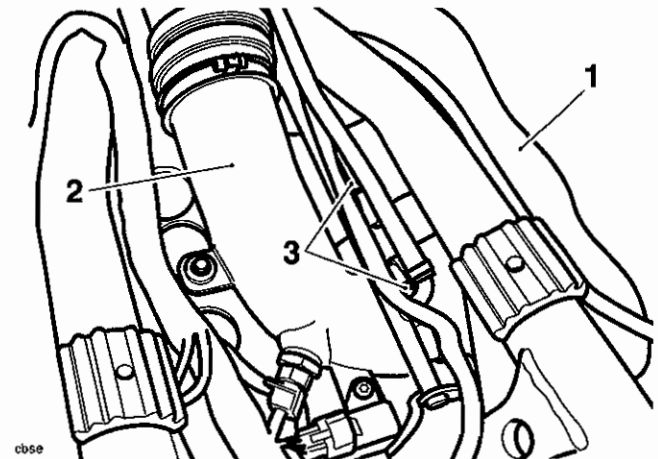

- cbse
1. Intake plenum
 2. Intake duct
 3. Clips

13. Reconnect the MAP and air temperature sensor connections.

Caution

Ensure the plenum is positively located to the throttle bodies and intake duct and is retained by the clips through their full circumference. Rectify if necessary as poor engine performance and damage may result from poor plenum/duct sealing.

14. Support the tank, remove and stow the tank prop, then lower the tank to the frame and secure it as described on page 11.99.
15. Refit the intake cover as described on page 11.99.
16. Reconnect the battery, positive (red) lead first.
17. Refit the rider's seat.

Injectors and Fuel Rail

Removal

1. Remove rider's seat.
2. Disconnect the battery, negative (black) lead first.
3. Remove the throttle bodies as described on page 11.122.
4. Remove the three screws securing the fuel rail and fuel hose to the throttle body assembly.

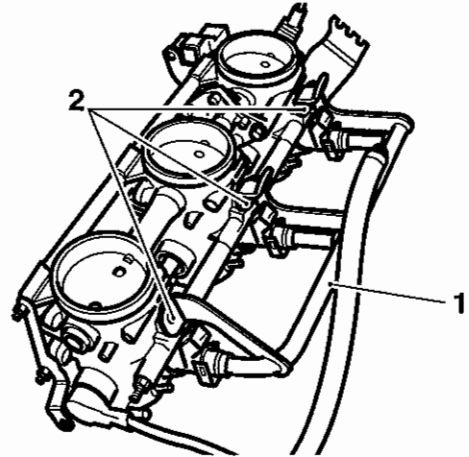

cbif

1. Fuel rail
2. Screws

Note:

- The fuel rail and injectors are removed from the throttle bodies together.
5. Gently ease the fuel rail and injectors upwards to release them from the throttles.

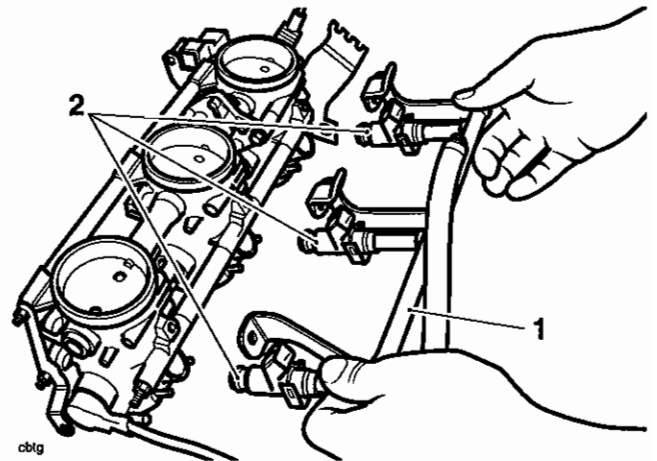

cbtg

1. Fuel rail
2. Injectors

- Ease the clips from the top of each injector.

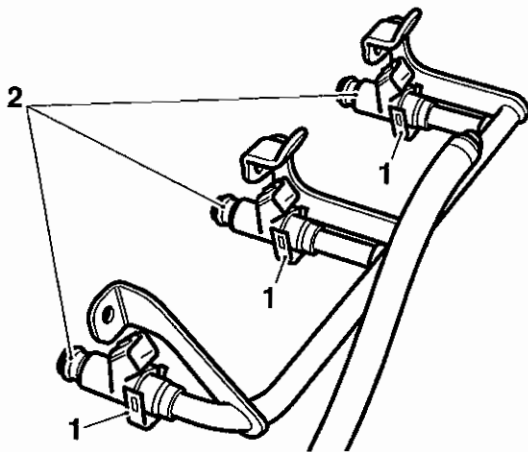

cbth

1. Clips

2. Injectors

- Ease each injector from the fuel rail.
- Recover the upper and lower O-rings from each injector.

Assembly/Installation

- Fit new O-rings to each injector.
- Locate each injector to the fuel rail
- Fit the injector/fuel rail assembly to the throttle body, orientating each injector such that the electrical connection is facing upwards (towards the second butterfly).
- Retain each injector with the clips removed earlier.
- Fit and tighten the fuel rail screws to **5 Nm**.
- Refit the throttle bodies as described on page 11.123.
- Reconnect the battery positive (red) lead first.
- Refit the rider's seat.

Primary Throttle Potentiometer

Note:

- The primary and secondary throttle position sensors are different and must never be transposed. For ease of identification, the primary throttle position sensor has a shorter connector cable than the secondary.

Removal

- Remove the rider's seat.
- Disconnect the battery, negative (black) lead first.
- Remove the throttle bodies as described on page 11.122.
- Remove the Torx screw securing the primary throttle position sensor to the throttle body.

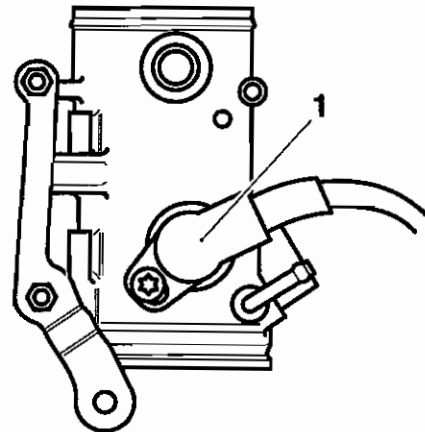

cbll

1. Primary throttle position sensor

- Turn the sensor anti-clockwise and detach it from the throttle body by gently pulling outwards.



Warning

Move the handlebars to left and right full lock while checking that cables and harnesses do not bind. A cable or harness that binds will restrict the steering and may cause loss of control and an accident.

15. Support the tank, remove and stow the tank prop, then lower the tank to the frame and secure it as described on page 11.99.
16. Refit the intake cover as described on page 11.99.
17. Reconnect the battery, positive (red) lead first.
18. Refit the rider's seat.

Secondary Throttle Potentiometer

Note:

- The primary and secondary throttle position sensors are different and must never be transposed. For ease of identification, the primary throttle position sensor has a shorter connector cable than the secondary.

Removal

1. Remove the rider's seat.
2. Disconnect the battery, negative (black) lead first.
3. Remove the throttle bodies as described on page 11.122.
4. Remove the Torx screw securing the secondary throttle position sensor to the throttle body.

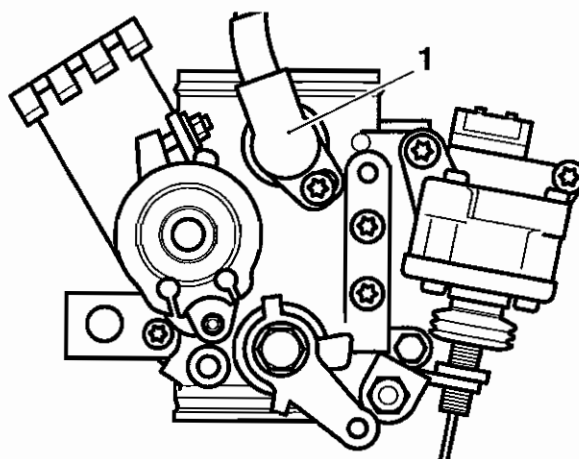

cbj

Secondary throttle position sensor

5. Turn the sensor clockwise and detach it from the throttle body by gently pulling outwards.

Installation

1. Lubricate the sensor 'O'-ring with a smear of petroleum jelly.
2. Manually push the second throttle to the fully open position.

- With the second throttle still held in the fully open position, insert the sensor to the throttle body at the angle shown below then turn it clockwise until the screw hole aligns with the thread in the throttle body.

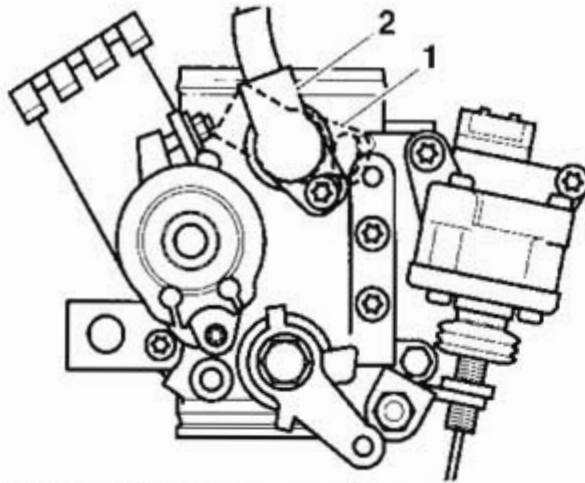

- Sensor insertion position (dotted line)
- Sensor initial fitted position (solid line)
- Insert the Torx screw but do not fully tighten yet.
- Release the second throttle.
- Refit the throttle bodies as described on page 11.123.
- Temporarily reconnect the battery, positive (red) lead first.
- Turn the ignition to the ON position, which will close the second throttle.

Note:

- To ensure the second throttle is totally closed, have an assistant manually press the butterfly closed.
- Connect the diagnostic tool and scroll through to the CHECK/ADJUST menu, select CHECK then select the 'READ SENSORS' followed by the VOLTAGES and SENSORS option.
 - Scroll through the data until the second throttle position sensor voltage is displayed.

| | | R E A D S E N S O R S | | |
|---------------------|-----------------|-------------------------|--|--------|
| C A L C U L A T E D | L O A D | | | 0 % |
| 2 N D | T H R O T T L E | | | 0.58 V |
| 2 N D | T H R O T T L E | | | 0 % |

- Gently rotate the new throttle position sensor until the voltage reading on the tool shows 0.6 volts +/- 0.02 volts.
- Tighten the sensor retaining screw to 3.5 Nm and recheck the voltage reading shown on the tool. Repeat the adjustment if the reading is outside the specified range.
- Disconnect the diagnostic tool.

- Disconnect the battery, negative (black) lead first.
- Check that the throttle opens and closes without obstruction/sticking and has a smooth action throughout the full range of its movement. Rectify as necessary.

Warning

Operation of the motorcycle with an incorrectly adjusted throttle position sensor, or a throttle position sensor that causes the throttle to stick could result in loss of throttle control. Loss of throttle control could result in loss of control of the motorcycle and an accident.

Warning

Operation of the motorcycle with an incorrectly adjusted, incorrectly routed or damaged throttle cable could interfere with the operation of the brakes, clutch or the throttle itself. Any of these conditions could result in loss of control of the motorcycle and an accident.

Warning

Move the handlebars to left and right full lock while checking that cables and harnesses do not bind. A cable or harness that binds will restrict the steering and may cause loss of control and an accident.

- Support the tank, remove and stow the tank prop, then lower the tank to the frame and secure it as described on page 11.99.
- Refit the intake cover as described on page 11.99.
- Reconnect the battery, positive (red) lead first.
- Refit the rider's seat.

Idle Speed Control Stepper Motor

Removal

1. Remove the rider's seat.
2. Disconnect the battery, negative (black) lead first.
3. Remove the throttle bodies as described on page 11.122.
4. Remove the nut, metal washer and plastic washer attaching the idle control stepper arm to the idle speed control lever.

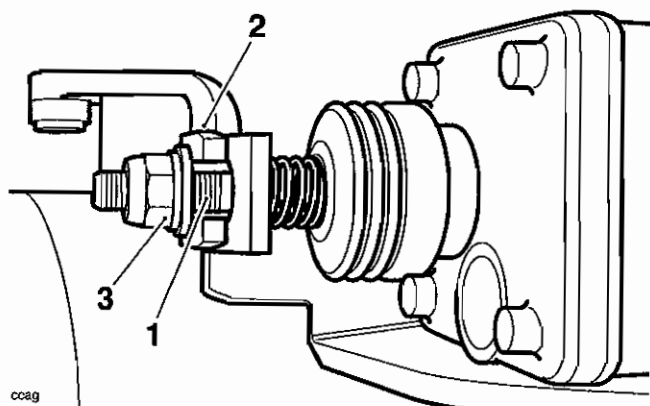

- ccag
1. Idle control stepper arm
 2. Idle speed control lever
 3. Nut etc.

5. Using the linkage, rather than the butterfly plates, fully open the primary throttle by hand.
6. Turn the idle speed control lever away from the stepper arm and remove the plastic collar and spring.

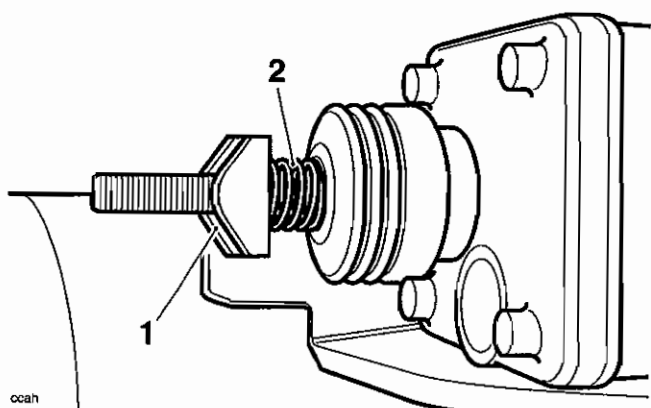

- ccah
1. Collar
 2. Spring

7. Remove the two screws securing the idle speed control stepper motor to its bracket, then remove the stepper motor.

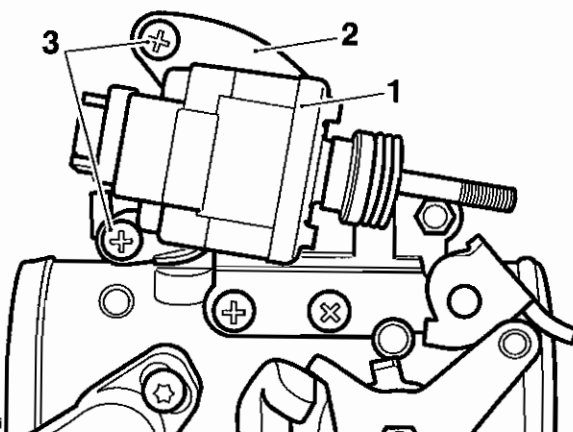

- ccal
1. Idle speed control stepper motor
 2. Bracket
 3. Fixings

Installation

1. Turn the idle speed control lever until the stepper motor can be fitted without obstruction of any kind.
2. Locate the stepper motor to its bracket and tighten the fixings to 3.5 Nm.
3. Locate the spring and plastic collar.

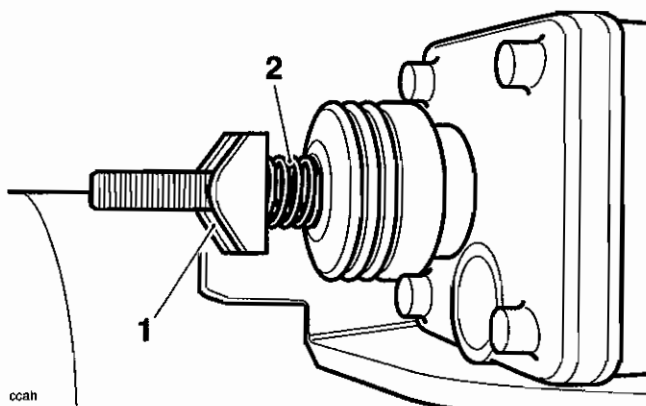

- ccah
1. Collar
 2. Spring

4. Fit the plastic washer through the lever then fit the metal washer and nut.
5. Refit the throttle bodies as described earlier in this section, but do not fit the intake cover.
6. Temporarily reconnect the battery, positive (red) lead first.
7. Turn the ignition to the ON position.
8. Connect the service diagnostic tool and scroll through to, and select the 'ADJUST TUNE' option.

- At the next screen, align the cursor with **ISC* STEPPER RENEW** (see below) then press the validation key which is marked '*'.
* ISC = Idle Speed Control

| | | | | | | | | | | | | | | | | | | | |
|---|---|---|---|---|---|---|---|---|---|---|---|---|---|---|---|---|---|--|--|
| | | | | | | | | A | D | J | U | S | T | T | U | N | E | | |
| | R | E | S | E | T | | A | D | A | P | T | I | O | N | S | | | | |
| | T | H | R | O | T | T | L | E | | P | O | T | R | E | N | E | U | | |
| ▶ | I | S | C | | S | T | E | P | P | E | R | | R | E | N | E | U | | |

- On pressing the validation key, the diagnostic tool will send a command that drives the primary throttle to the fully closed position. The tool will also display the voltage reading coming from the throttle position sensor which will be needed for a check/adjustment made later in the process.

| | | | | | | | | | | | | | | | | | | | | | | |
|--|---|---|---|---|---|---|---|---|---|---|---|---|---|---|---|---|---|---|---|---|---|---|
| | | | | | | | | | | | | | | | | | | | | | | |
| | R | E | P | L | A | C | E | | I | S | C | | S | T | E | P | P | E | R | | | |
| | | | | | | | | T | H | R | O | T | T | L | E | | C | L | O | S | E | D |
| | C | U | R | R | E | N | T | | V | O | L | T | S | | | 0 | . | 5 | B | V | | |

- Tighten the stepper arm nut until a clearance of 0.5 mm can be measured between the idle speed control cam and the throttle roller (see the diagram below).

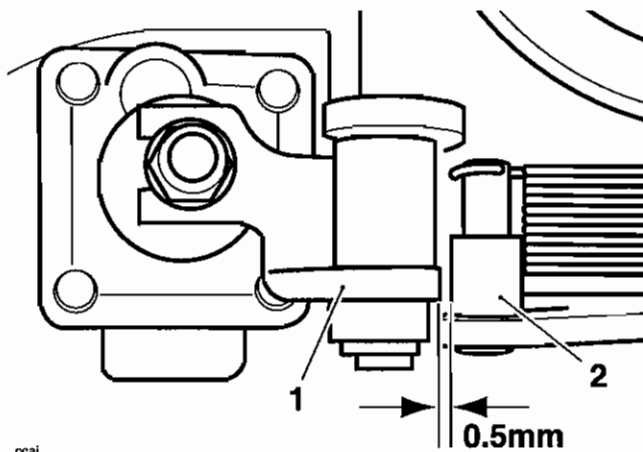

- Idle speed control cam
- Throttle roller

- Check the voltage reading on the tool. If the reading is 0.6 volts +/- 0.02 volts, **MAKE A NOTE OF THE EXACT VOLTAGE READING** then proceed to step 18. If the reading is not within this tolerance band, adjustment must be made as described in steps 13 to 15.
- Slacken the retaining screw on the primary throttle position sensor.

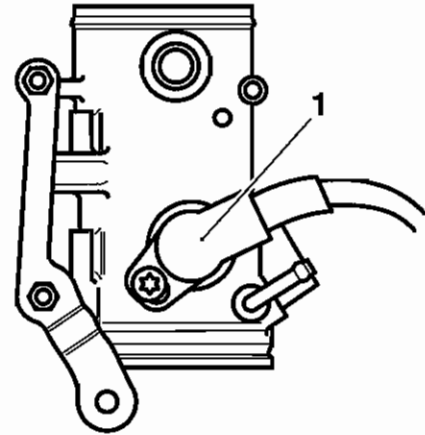

cbtl

1. Primary throttle position sensor

- Gently turn the primary throttle position sensor until the voltage reading on the tool shows 0.6 volts +/- 0.02 volts. **MAKE A NOTE OF THE EXACT VOLTAGE READING.**
- Tighten the sensor retaining screw to 3.5 Nm and recheck the voltage reading shown on the tool. Repeat the adjustment if the reading is outside the specified range, **NOTING THE FINAL VOLTAGE READING IF ADJUSTMENT IS MADE.**
- Press the validation key marked '*' to progress to the next adjustment.
- On pressing the validation key, the diagnostic tool will send a command that drives the primary throttle to the fully open position. The tool will also display the voltage reading coming from the throttle position sensor.

| | | | | | | | | | | | | | | | | | | | | | | |
|--|---|---|---|---|---|---|---|---|---|---|---|---|---|---|---|---|---|---|---|---|--|--|
| | | | | | | | | | | | | | | | | | | | | | | |
| | R | E | P | L | A | C | E | | I | S | C | | S | T | E | P | P | E | R | | | |
| | | | | | | | | T | H | R | O | T | T | L | E | | O | P | E | N | | |
| | C | U | R | R | E | N | T | | V | O | L | T | S | | | 0 | . | 7 | 2 | V | | |

Fuel System/Engine Management

18. With the stepper fully opened, check the voltage shown on the tool and adjust the nut on the top of the stepper arm until the tool shows a voltage equivalent to $X+0.12$ (+/- 0.05V) where X= the voltage measured in step 12 (or 15 if re-adjusted).

For example, if the voltage measured was 0.6 volts, then the correct setting would be 0.715-0.725 volts.

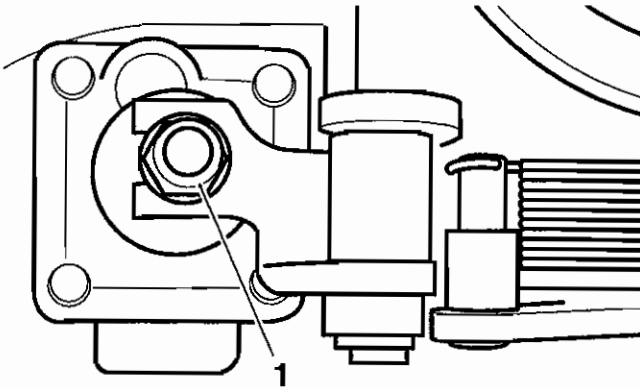

ccak

1. Adjustment nut.

19. Press the validation key marked "*" to fully close the idle speed control stepper motor. After a minimum of 15 seconds (the tool will not allow further actions to take place during this period), press the validation key again to return the ECM to normal control.
20. Turn the ignition to the OFF position.
21. Disconnect the battery, negative (black) lead first.
22. Check and adjust the throttle cable settings as described on page 11.119).

Warning

Operation of the motorcycle with an incorrectly adjusted throttle position sensor, or a throttle position sensor that causes the throttle to stick could result in loss of throttle control. Loss of throttle control could result in loss of control of the motorcycle and an accident.

Warning

Operation of the motorcycle with an incorrectly adjusted, incorrectly routed or damaged throttle cable could interfere with the operation of the brakes, clutch or the throttle itself. Any of these conditions could result in loss of control of the motorcycle and an accident.

Warning

Move the handlebars to left and right full lock while checking that cables and harnesses do not bind. A cable or harness which binds will restrict the steering and may cause loss of control and an accident.

23. Support the tank, remove and stow the tank prop, then lower the tank to the frame and secure it as described on page 11.99.
24. Refit the intake cover as described on page 11.99.
25. Reconnect the battery, positive (red) lead first.
26. Refit the rider's seat.

Engine Management Adaption

General Information

The engine management system fitted to this model is adaptive. This means that the system is able to learn about new or changing operating conditions and continuously adapt itself without needing to constantly make major adjustments from a fixed baseline setting.

Adaptive changes can become necessary because of changing rider behavior, changes in the region in which the bike is operated (i.e. operation at high altitude where it was previously used at sea level) or because a new part may have been fitted which has slightly different characteristics to the old part. All adaptive changes are automatic and require no intervention by rider or dealer.

Adaption Status

To see if a motorcycle has fully adapted, a facility named 'ADAPTION STATUS' is provided on the diagnostic tool. The following adaption details can be examined:

| Function Examined | Report Method |
|---|---------------------|
| Closed throttle position reference status | adapted/not adapted |
| Idle speed control adaption status | % |
| Oxygen sensor adaption status (off idle) | % |
| Oxygen sensor adaption range (off idle) | % |
| Oxygen sensor adaption status (idle) | % |
| Oxygen sensor adaption range (idle) | % |

Terminology

Where the term 'status' is used, this indicates how far the present operating parameter is from the stored (baseline) value. The nearer these figures are to zero the better as it indicates the motorcycle has adapted to its current operating conditions.

The term 'range' indicates how much (in percentage terms) of the adjustment range has been used to reach the current operating status.

Typical Values

In a correctly adapted motorcycle, the following will be typical:

| Function Examined | Read Out |
|---|------------------------|
| Closed throttle position reference status | Adapted |
| Idle speed control adaption status | Between +100 and -100% |
| Oxygen sensor adaption status (off idle) | 0% +/- 10% |
| Oxygen sensor adaption range (off idle) | Between +100 and -100% |
| Oxygen sensor adaption status (idle) | 0% +/- 10% |
| Oxygen sensor adaption range (idle) | Between +100 and -100% |

- Forcing adaption to take place

If the read out indicates that the motorcycle is not adapted, the following will force the system to make adaptations:

1. Ensure the engine is cold.
2. WITHOUT TOUCHING THE THROTTLE, start the engine and allow it to warm up until the cooling fan comes on.
3. Leave the engine to idle for a further 12 minutes.

Note:

- As an alternative to the above process, connect the diagnostic tool, scroll to **ADJUST TUNE** and select **RESET ADAPTIONS**. This will force a fast adaption routine to take place in around 5 seconds. For this to happen, the engine **MUST** be running, it must be at normal operating temperature and in closed loop control mode. Under any other conditions fast adaption will not take place and may cause default values to be loaded, which may then require a normal 12 minute adaption routine to be run.

Fuel System/Engine Management

Fault Indications

If 'range' figures at 100% are seen, then the adjusted has reached maximum indicating a mechanical fault exists on the motorcycle. This can be due to a number of faults but the most likely causes will be low/high fuel pressure, faulty injectors or air leaks at the throttle bodies or airbox.

In these circumstances, locate and rectify the fault, use the RESET ADAPTIONS facility on the diagnostic tool (found under the adjust tune menu) and begin the adaption process described above.

Exhaust System

Removal

Warning

If the engine has recently been running, the exhaust components may be hot to the touch. Contact with the hot components may cause damage to exposed skin. To avoid skin damage, always allow the hot parts to cool before working on the exhaust system.

Note:

- In the following procedures, the term catalyst box refers to the rectangular chamber to which the silencers are attached. In many countries, catalytic converters are fitted inside this component. However, in certain countries (depending on their exhaust emission regulation) no catalyst will be fitted.

Note:

- Always note the position and orientation of exhaust clamps prior to releasing them, and return them to the noted position and orientation on assembly.

1. Remove the catalyst box/silencer heat shields.

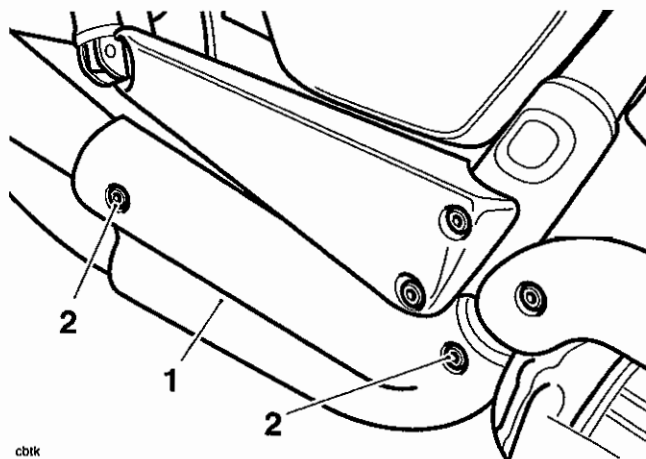

cbtk

1. Heat Shield
 2. Heat shield fixings
2. Disconnect the battery, negative (black) lead first.

3. Release the clamps securing the silencers to the catalyst box.

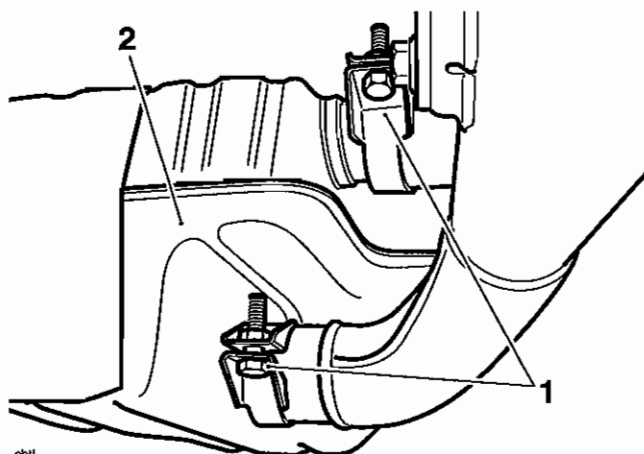

- cbtl
1. Silencer clamp fixings
 2. Catalyst box

4. Release the fixing securing the silencers to their brackets.

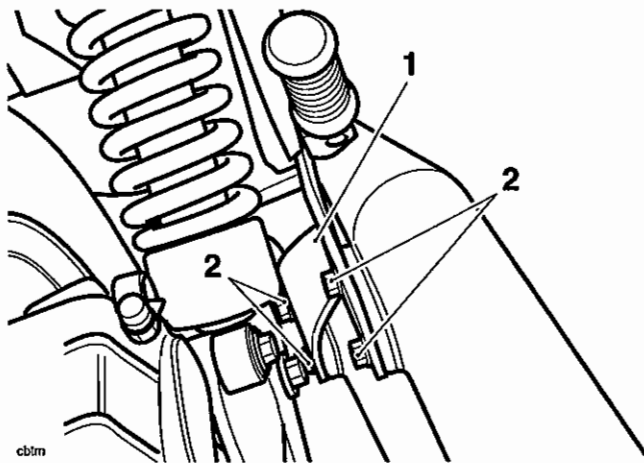

- cbtm
1. Silencer bracket
 2. Fixings

5. Detach the silencers from the catalyst box.
6. Collect the silencer gaskets.
7. Disconnect the oxygen sensor connection from the wiring harness.
8. Remove the upper heat shields from the exhaust headers.

9. Remove the lower heat shield from the headers. After removal, collect the small rubber isolators from the brackets on the inner heat shield (or on a tag on the end of the upper shields, depending on where they are retained).

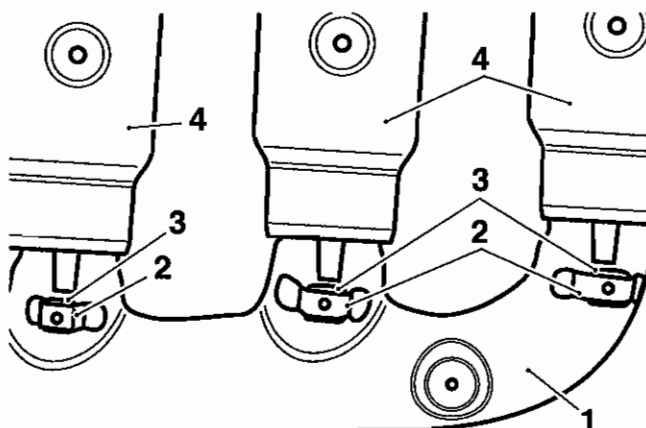

- cbtm
1. Lower heat shield
 2. Isolator brackets
 3. Isolators
 4. Upper heat shields

10. Release the clamp securing the headers to the catalyst box.
11. At the cylinder head, release the nuts securing the header pipes to the head.

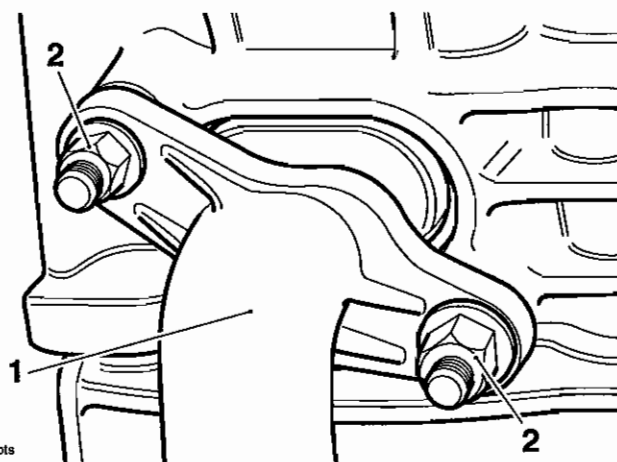

- cbts
1. Header downpipe
 2. Fixings

12. Detach and remove the header assembly.
13. Collect the header gaskets from the head and catalyst box entry.

Note:

- The catalyst box is secured to the frame by a single fixing on the right hand side, and is located on two studs on the left hand side.

Fuel System/Engine Management

⚠ Caution

The catalyst box is located very close to the starter cables. Ensure you have disconnected the battery. Otherwise an electrical short may occur.

14. Release the fixing securing the catalyst box to the frame.

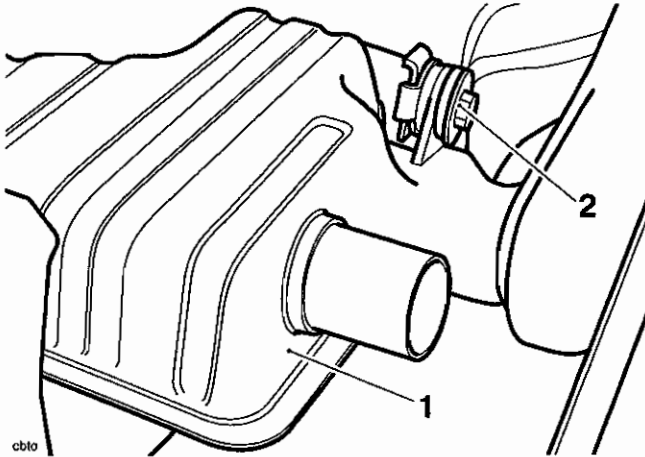

- cbto
1. Catalyst box
 2. Fixing

15. Detach the catalyst box by easing it to the right hand side of the motorcycle.

Note:

- Catalyst box mounting grommets may remain in the catalyst box or may adhere to the mounting studs on removal of the catalyst box.

16. Collect the catalyst box mounting grommets.

Installation

1. Check and if necessary renew the catalyst mounting box grommets. Fit the mounting grommets to the mounting points on the catalyst box.
2. Locate the catalyst box to the mounting studs on the right hand side. Insert the flanged sleeve into the right hand grommet and then fit the bolt and washer to retain the assembly.

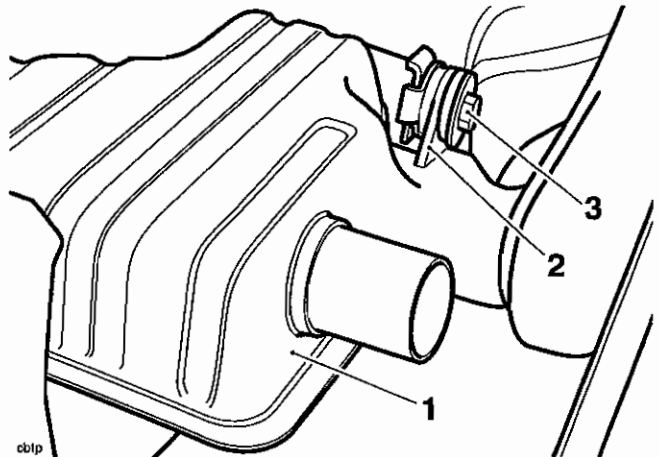

- cbtp
1. Catalyst box
 2. Right hand mounting
 3. Bolt/washer

3. Fit new gaskets to the cylinder head ports.

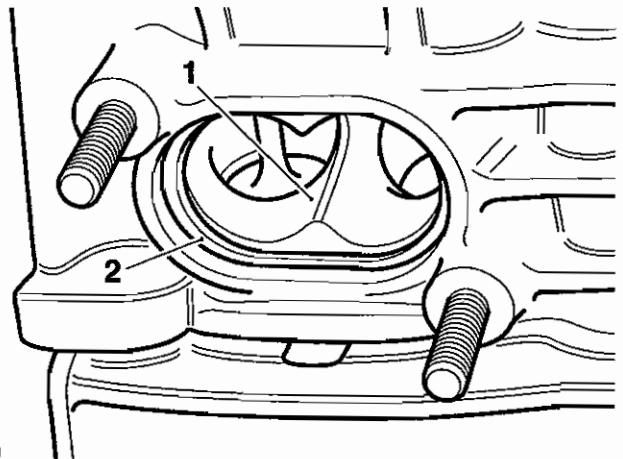

- cbtq
1. Cylinder head ports
 2. Gaskets

Note:

- To retain the gaskets during assembly, apply a smear of grease or petroleum jelly to the gasket faces in the head.
4. Apply 'Copperslip' grease to the header studs on the cylinder head.
 5. Fit a new gasket to the header entry to the catalyst box and position the clamp over the joint.
 6. Locate the headers to the catalyst box, then align to the cylinder head. Ensure the gaskets do not become displaced during assembly.

7. Tighten all the header nuts to **19 Nm**.
8. Tighten the catalyst box mounting bolt to **27 Nm**.
9. Tighten the header to catalyst box clamp bolt to **22 Nm**.
10. If removed, fit the oxygen sensor and tighten it to **40 Nm**.
11. Reconnect the oxygen sensor to the main wiring harness.
12. Fit the isolator rubbers to the tags at the bottom of the upper heat shields.
13. Position the lower heat shields to the header pipes.
14. Fit the lower heat shield screws; spring washers and flat washers, then tighten the screws to **7 Nm**.
15. Position each of the upper heat shields to the headers, engaging the isolators in the corresponding brackets in the lower inner heat shield.
16. Fit the upper heat shield screws; spring washers and flat washers, then tighten the screws to **7 Nm**.
17. Fit new gaskets to each silencer.
18. Position the silencer clamps to each catalyst box exit.
19. Fit each silencer to the catalyst box and position to the silencer brackets.
20. Engage the mounting bracket fixings, finger tight.
21. Tighten each silencer bracket fixing to **15 Nm**.
22. Tighten each silencer clamp to **22 Nm**.
23. Position the heat shields to the silencers.
24. Fit the silencer heat shield screws; spring washers and flat washers, then tighten the screws to **7 Nm**.
25. Reconnect the battery, positive (red) lead first.

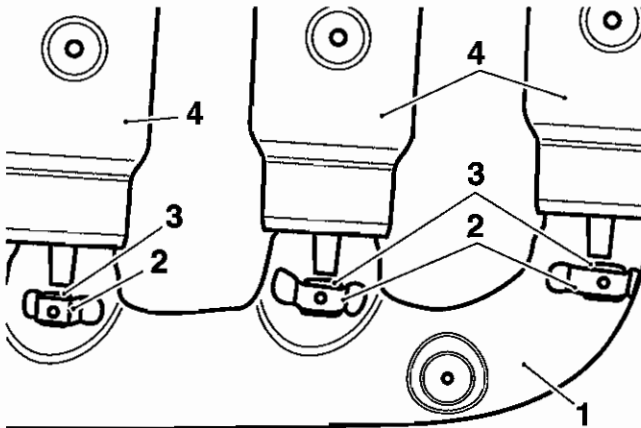

cbfn

1. Lower heat shield
2. Bracket
3. Isolator
4. Upper heat shields

Fuel System/Engine Management

Evaporative Loss Control System - California Models Only

California Models Only

All California models are fitted with an evaporative emissions control system to prevent the exhausting of fuel vapour into the atmosphere.

A canister containing activated charcoal, located beneath the left hand side cover, absorbs hydrocarbon vapour given off by the fuel in the fuel tank. Vapour delivery to the canister occurs at all times, but is particularly high after riding, when the motorcycle is parked in direct sunlight or in high temperatures. This causes the fuel temperature in the fuel tank to rise, resulting in a rise in the vapour pressure inside the tank. Normally this vapour would be vented to atmosphere but on California models, it is stored in the charcoal canister.

When the engine is started, the vapour is returned to the throttle body by means of induction vacuum, and is burnt in the engine.

There are two distinct phases to the system's operation, engine off and engine running. These two conditions are explained overleaf.

Component Locations (all situated behind the left hand side cover)

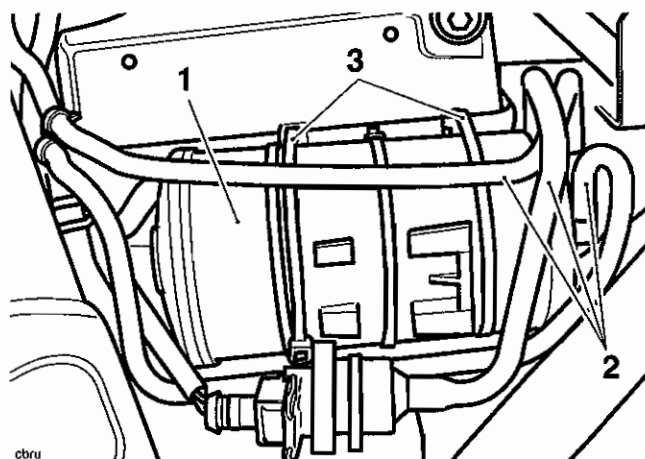

cbru

1. Carbon canister
2. Purge valve
3. Canister ties

Evaporative Control System - Engine Off

When the engine is switched off, hydrocarbon fuel vapour passes down the breather pipe A, through the roll-over valve to the canister. Vapour is then stored in charcoal layers within the canister.

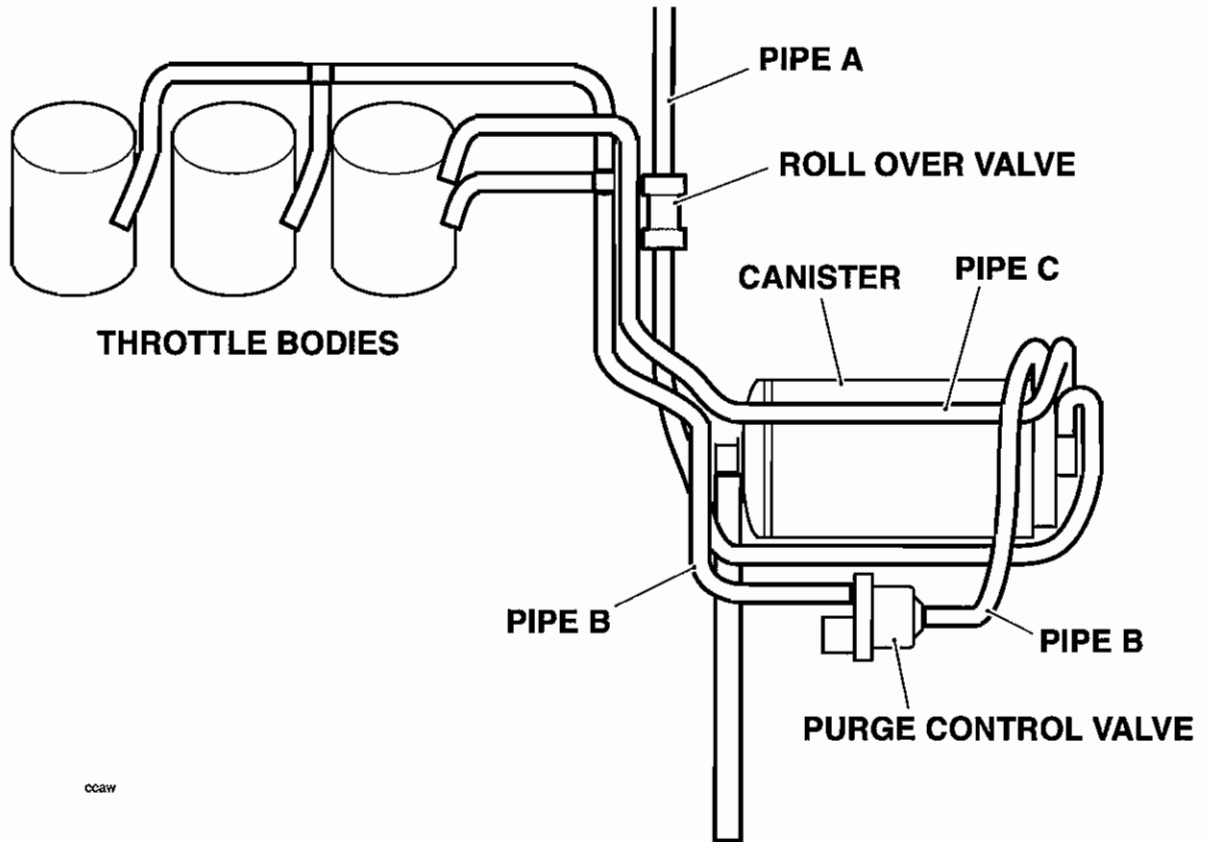

Fuel System/Engine Management

Evaporative Control System - Engine Running

When the engine is started, vacuum from the engine is applied through pipe C to the vacuum switch on the canister, causing the canister return valve to open. Direct return of vapour, along pipe B, to the throttle bodies is prevented by the purge control valve which is governed by the engine management system. When open, the valve allows stored vapour to return to the throttle bodies where it enters the engine and is burnt in the cylinders.

The purge control valve is shuttled between the open and closed position during purging to prevent transient rich mixture and high emissions.

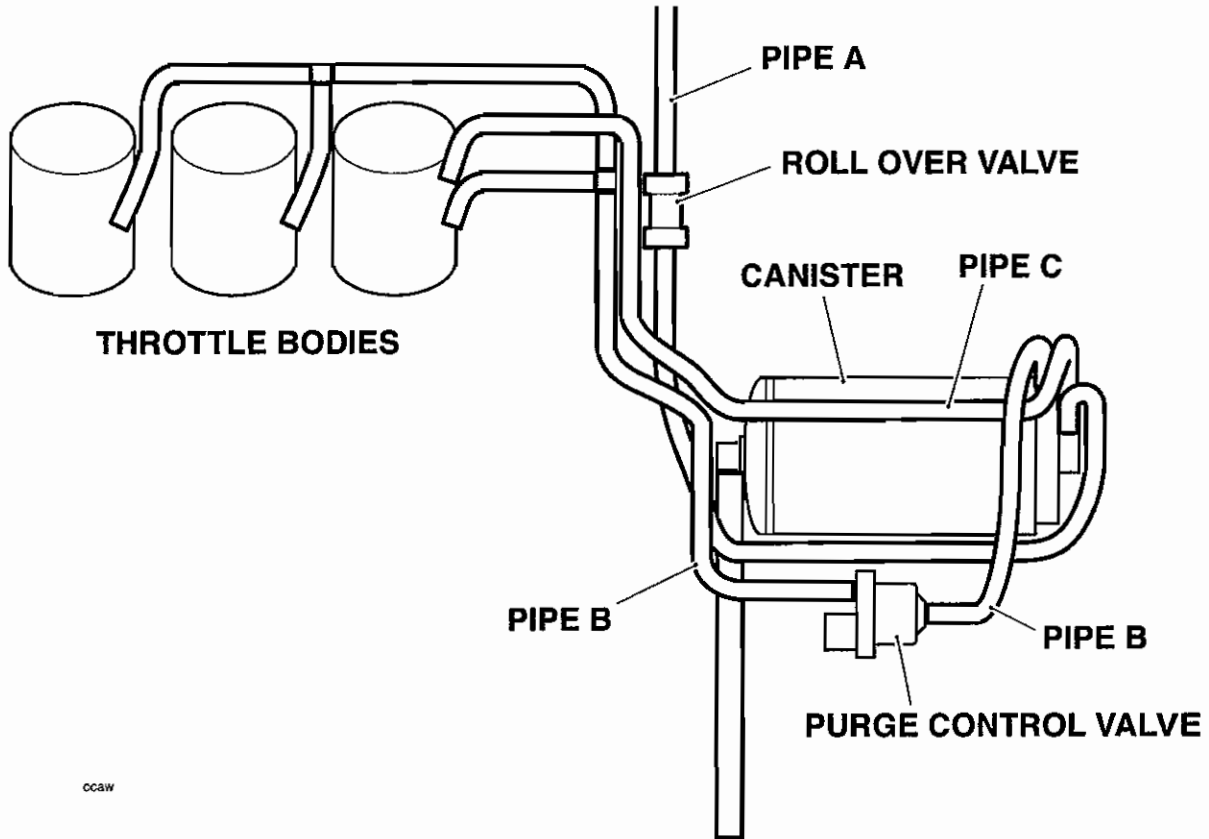

12 Cooling

Table of Contents

| | |
|--|-------|
| Exploded View - Radiator | 12-2 |
| Exploded View - Water Pump, Expansion Tank and Hoses | 12-3 |
| Coolant | 12-4 |
| Radiator Hoses | 12-4 |
| Radiator and Cooling Fan | 12-4 |
| Coolant Level Inspection | 12-5 |
| Coolant Level Adjustment | 12-5 |
| Coolant Replacement | 12-6 |
| Drainage | 12-6 |
| Filling | 12-7 |
| Water Pump | 12-7 |
| Removal | 12-7 |
| Inspection | 12-8 |
| Installation | 12-8 |
| Coolant Pressure Cap | 12-9 |
| Inspection | 12-9 |
| Thermostat | 12-9 |
| Removal | 12-9 |
| Inspection | 12-10 |
| Installation | 12-10 |
| Radiator | 12-11 |
| Removal | 12-11 |
| Inspection | 12-13 |
| Installation | 12-13 |

Cooling

Exploded View - Radiator

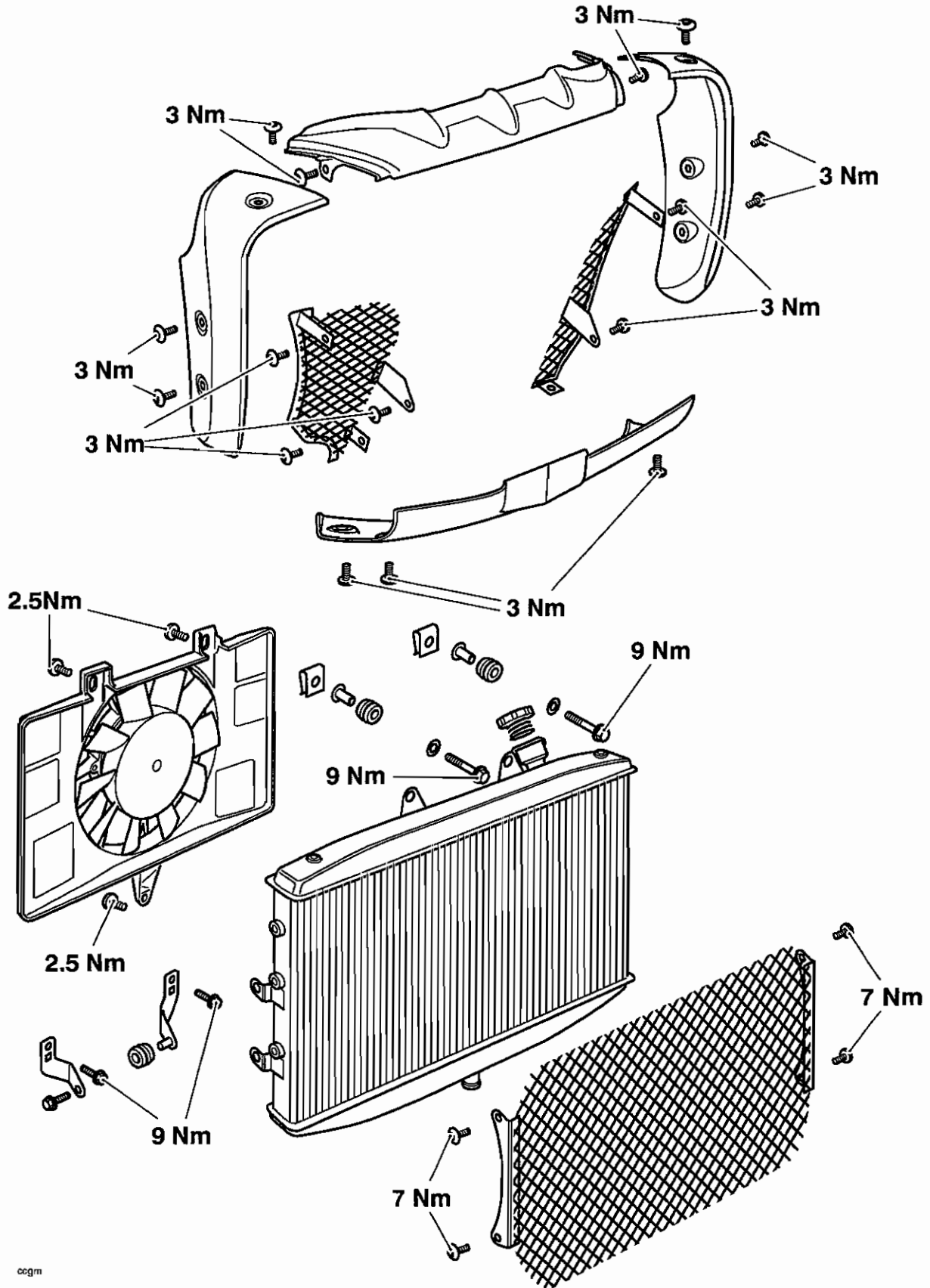

Exploded View - Water Pump, Expansion Tank and Hoses

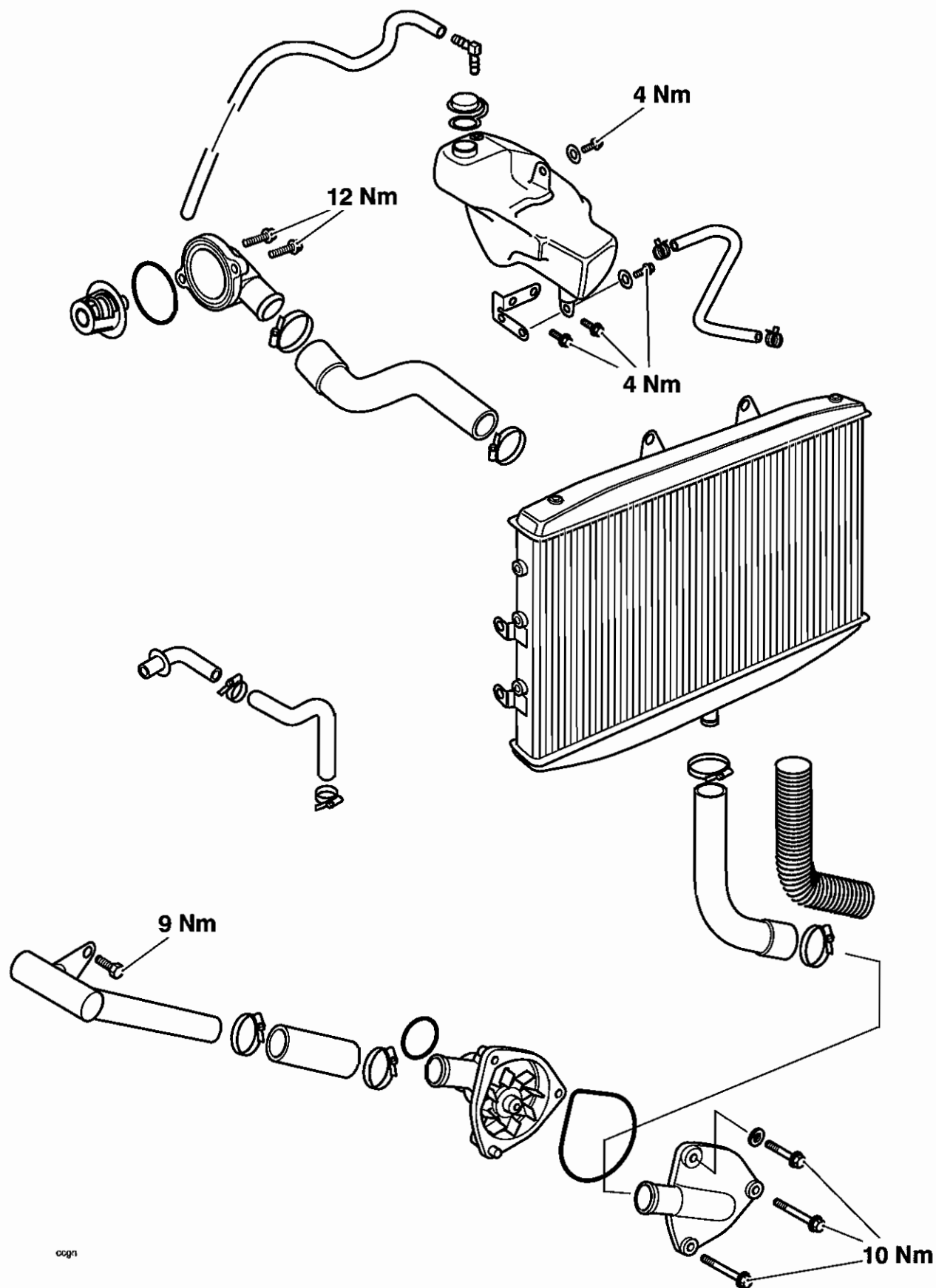

0091

Cooling

Coolant

A all-seasons type of anti-freeze is installed in the cooling system when the motorcycle leaves the factory. It is coloured blue, contains a 50% solution of ethylene glycol, and has a freezing point of -35°C (-31°F).

Always change the coolant at the intervals specified in the scheduled maintenance chart.

Warning

The standard coolant mixture contains toxic chemicals that are harmful to the human body. Never swallow neat anti-freeze or any of the coolant mixture.

Caution

The anti-freeze incorporated in the coolant mixture contains a corrosion inhibitor that helps prevent damage to the cooling system and engine. Without this inhibitor, the coolant would 'attack' the metals and the resulting corrosion would cause blockages in the cooling system leading to engine overheating and damage.

Always use the anti-freeze listed in the specification section and never use a methanol based anti-freeze as this does not contain the required corrosion inhibition properties.

Caution

Distilled water must be used to dilute anti-freeze to the correct mixture ratio. If hard water is used in the cooling system, it causes scale accumulation in the engine and radiator and considerably reduces the efficiency of the cooling system. Reduced cooling system efficiency may cause the engine to overheat and suffer severe damage.

Radiator Hoses

Regularly check all radiator hoses and hose clips for cracks, leaks or deterioration.

Radiator and Cooling Fan

The motorcycle is fitted with a thermostatically controlled electric fan situated behind the radiator. The fan cowl is fitted with six flap valves to add control to the air flow through the radiator. When the motorcycle is operated at speed and the fan is off, the flap valves open to allow more air flow through the radiator. When the fan operates with the motorcycle stationary or at slow speed, the valves close to ensure cool air is drawn through the radiator from the front of the motorcycle.

Check the radiator fins for obstruction by insects, mud, leaves and general debris. Clean off any obstructions by hand or with a stream of low-pressure water. Ensure the flap valves are not blocked or obstructed and are free to operate.

Caution

Using high-pressure water, as from a pressure-washer, can damage the radiator fins and impair the radiator's efficiency.

Do not obstruct or deflect airflow through the radiator by installing unauthorized accessories in front of the radiator or behind the cooling fan. Interference with the radiator airflow can lead to overheating and consequent engine damage.

Coolant Level Inspection



Before starting work, ensure the motorcycle is stabilised and adequately supported. This will help prevent it from falling and causing injury to the operator or damage to the motorcycle.

1. Position the motorcycle on level ground and in an upright position.

Note:

- The coolant level within the expansion tank can be inspected, without removing any covers, by looking between the fuel tank and frame headstock on the left hand side of the motorcycle. Always inspect the coolant level with the engine cold.
2. The coolant level must be between the 'MAX' (upper line) and 'MIN' (lower line) marks in the expansion tank.

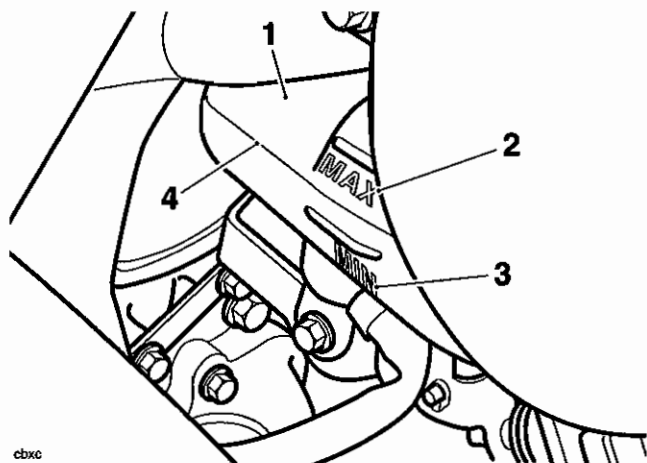

1. Expansion tank
2. MAX mark
3. MIN mark
4. Fluid level

3. If the coolant is below the minimum level, or exceeds maximum, the coolant level must be adjusted.

Coolant Level Adjustment



Before starting work, ensure the motorcycle is stabilised and adequately supported. This will help prevent it from falling and causing injury to the operator or damage to the motorcycle.



Do not remove the expansion tank or radiator pressure cap when the engine is hot. When the engine is hot, the coolant inside the expansion tank will be hot and also under pressure. Contact with hot coolant will cause scalds and skin damage.

1. Allow the engine to cool for at least 30 minutes.
2. Remove the intake cover as follows: Release the two screws from its front and rear edges and then slide it downwards to release it from two support studs in its centre.

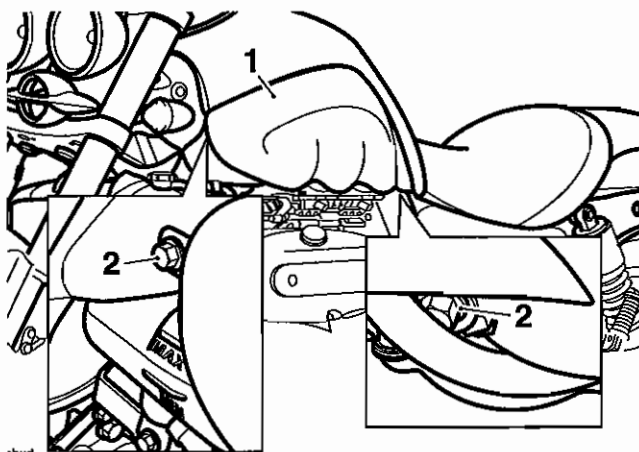

1. Intake cover
2. Intake cover screws

3. Remove the cap from the expansion tank, and add coolant mixture through the filler opening until the level reaches the 'MAX' mark. Refit the cap.

Note:

- If the coolant level is being checked because the coolant has overheated, also check the level in the radiator and top-up if necessary. In an emergency, water alone can be added to the cooling system. However, the coolant must be returned to the correct mixture ratio as soon as possible.
4. Refit the intake cover as follows: Align the cover to the centre studs and ease it into place. Fit and tighten the two screws to 9 Nm.

Cooling

Coolant Replacement

Drainage

Warning

Do not remove the coolant pressure cap when the engine is hot. When the engine is hot, the coolant inside the radiator is hot and also under pressure. Contact with hot coolant will cause scalds and skin damage.

Warning

Before starting work, ensure the motorcycle is stabilised and adequately supported. This will help prevent it from falling and causing injury to the operator or damage to the motorcycle.

1. Remove the left hand radiator cover.

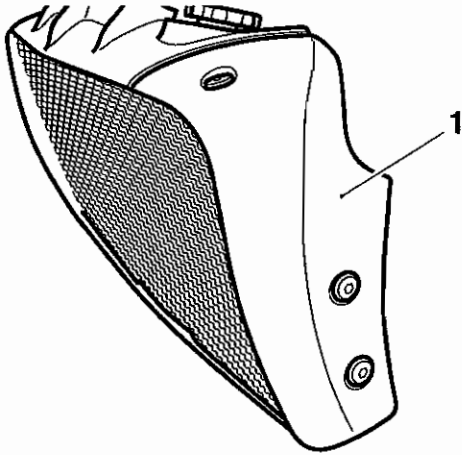

coek

1. Radiator cover

2. Release the security screw and remove the coolant pressure cap on the radiator.

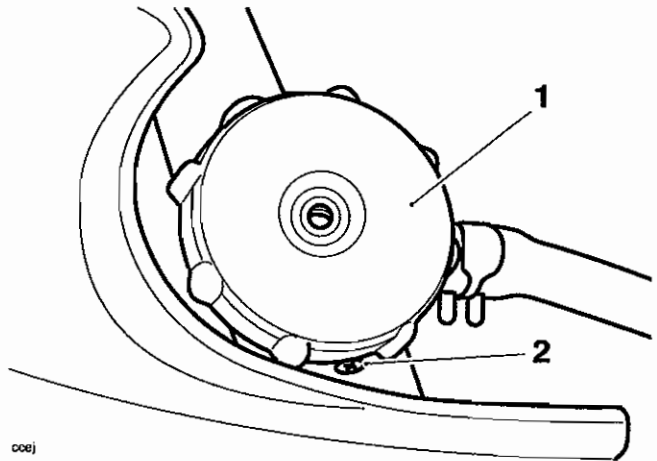

coej

1. Radiator cap
2. Security screw
3. Position a container beneath the water pump to collect the displaced coolant.
4. Detach the bottom hose from the water pump and allow the coolant to drain out.

Note:

- To facilitate full drain out, also remove the drain plug from the water pump.

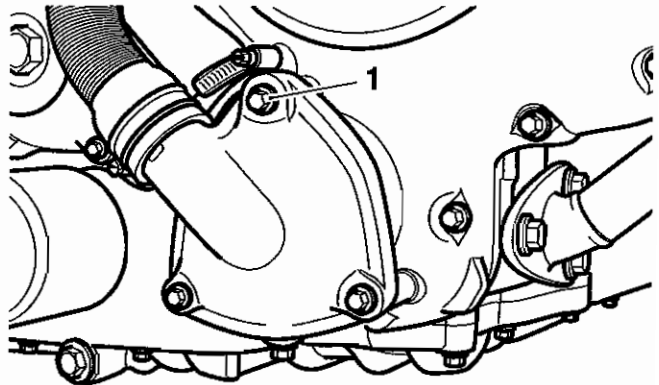

cbxg

1. Water pump drain plug

Filling

1. If removed, refit the water pump drain plug. Tighten the plug to **10 Nm**.
2. Reconnect the bottom hose and tighten the clip.
3. Open the cooling system bleed screw.

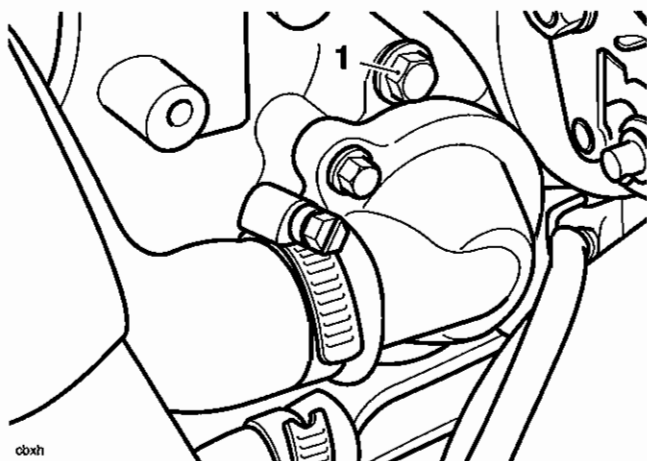

cbxh

1. Bleed screw

4. Slowly add coolant mixture to the system, through the filler opening in the radiator, until coolant escapes from the bleed screw. Close the bleed screw, tightening it to **10 Nm**.
5. If necessary, top up the system through the radiator filler.
6. Refit the pressure cap.
7. Start the motorcycle and allow the engine to idle for a short period of time to allow any air to be expelled from the system.

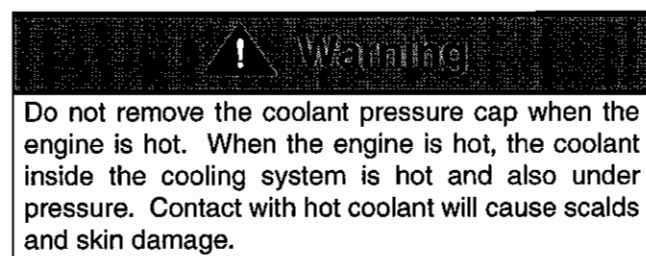

8. Stop the engine and top up the coolant level as necessary.
9. Refit the coolant pressure cap and tighten the security screw to **3 Nm**.
10. Refit the left hand radiator cover, tightening the fixings to **3 Nm**.
11. Check the expansion tank level and top up if necessary (see page 12.5).

Water Pump

Removal

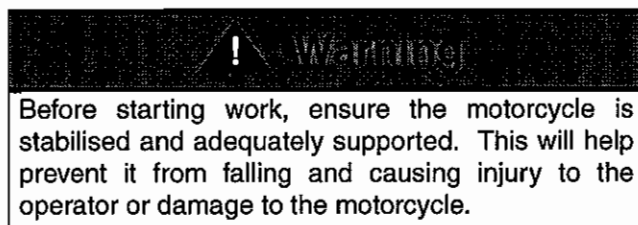

1. Remove the rider's seat.
2. Disconnect the battery, negative (black) lead first.
3. Drain the coolant as described earlier.

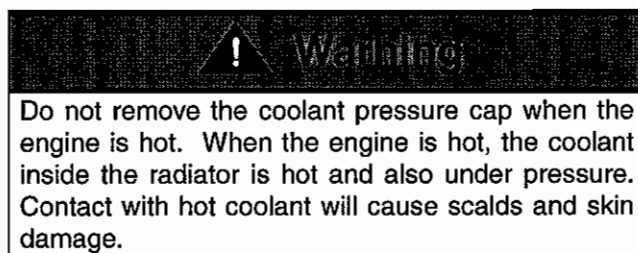

4. Turn the steering to left or right full lock.
5. Disconnect the coolant hoses from the water pump.

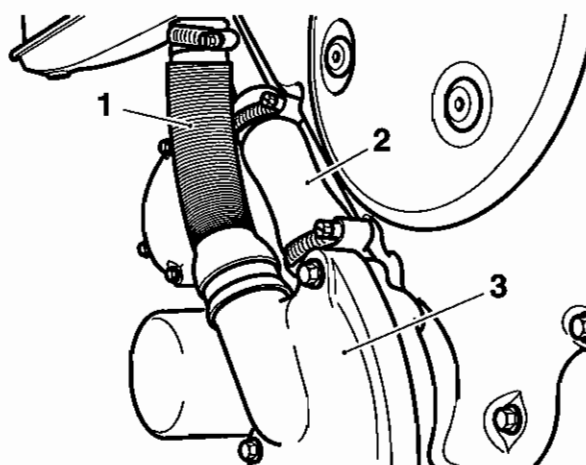

cbxi

1. Bottom radiator hose
2. Pump outlet hose
3. Water pump

6. Release the two lower bolts that secure the water pump to the crankcase.

Note:

- **The third, upper bolt is the drain plug and also holds the water pump together.**

7. Withdraw the water pump.

Cooling

Inspection

1. Remove the pump outer cover to check for corrosion and scale build-up around the impellor and in the pump body. Renew if necessary.
2. Check the water pump shaft and shaft bearings for side and end float. Clean or renew if necessary.
3. Check the water pump gland for signs of leakage. Renew the pump if leakage is evident.

Installation

1. Replace the water pump 'O' ring seal.

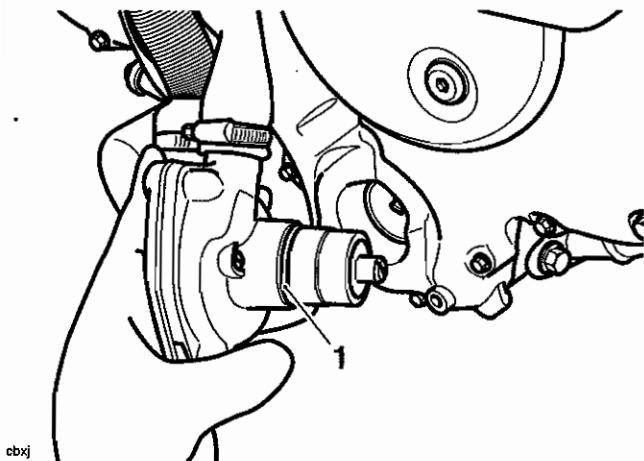

1. 'O' ring seal

2. Align the drive slot in the water pump with the drive blade on the oil pump shaft (inside the crankcase).

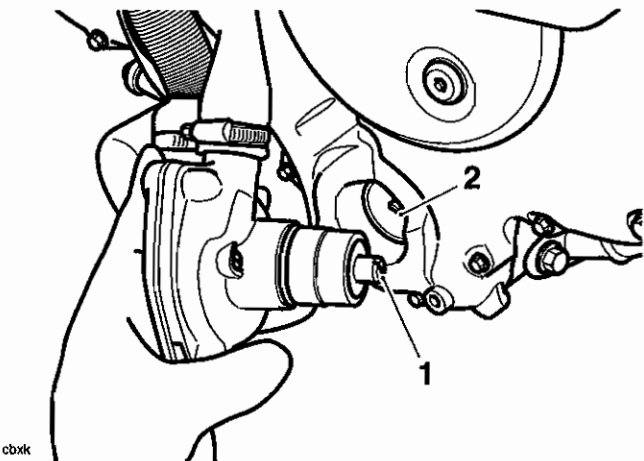

Note:

- The water pump will not engage fully into the crankcase unless the drive slot and blade are aligned and engaged.

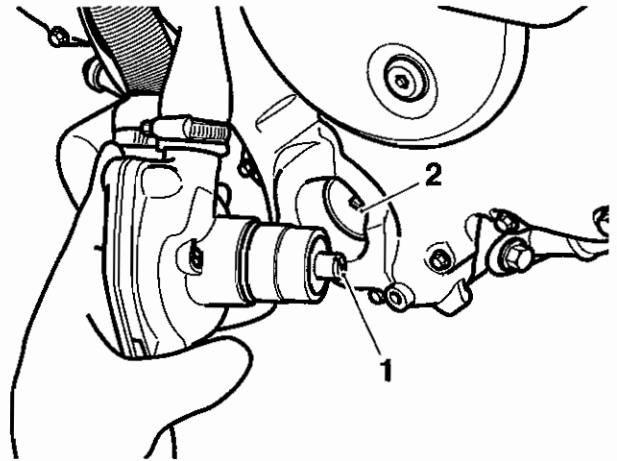

1. Water pump slot

2. Oil pump shaft, drive blade

3. Fit the pump and tighten the fixings to **10 Nm**.
4. Refit the hoses to the water pump and tighten the clips.
5. Reconnect the battery, positive (red) lead first.
6. Refit the rider's seat.
7. Refill the cooling system as described on page 12.7.

Coolant Pressure Cap

Inspection

Warning

Do not remove the coolant pressure cap when the engine is hot. When the engine is hot, the coolant inside the radiator is hot and also under pressure. Contact with hot coolant will cause scalds and skin damage.

Warning

Before starting work, ensure the motorcycle is stabilised and adequately supported. This will help prevent it from falling and causing injury to the operator or damage to the motorcycle.

1. Remove the pressure cap as described in the coolant drain section on page 12.6.
2. Check condition of the upper and lower seals of the coolant pressure cap.

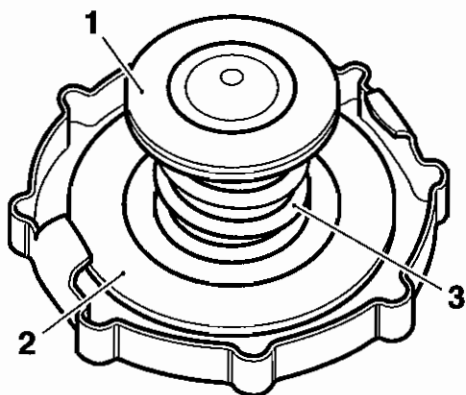

ocer

1. Lower Seal
2. Upper Seal
3. Spring

Note:

- If there is any sign of damage or deterioration replace the cap.
3. Pressure test the cap to the blow off pressure of 1.2 bar using proprietary tools. If the cap opens at a lower pressure or fails to open at 1.2 bar, replace the cap.
 4. Refit the pressure cap as described in the coolant fill section on page 12.7.

Thermostat

Removal

Warning

Before starting work, ensure the motorcycle is stabilised and adequately supported. This will help prevent it from falling and causing injury to the operator or damage to the motorcycle.

1. Remove the rider's seat.
2. Disconnect the battery, negative (black) lead first.
3. Drain the coolant as described on page 12.6.

Warning

Do not remove the coolant pressure cap when the engine is hot. When the engine is hot, the coolant inside the radiator is hot and also under pressure. Contact with hot coolant will cause scalds and skin damage.

4. Disconnect the top and bypass hoses at the thermostat housing.

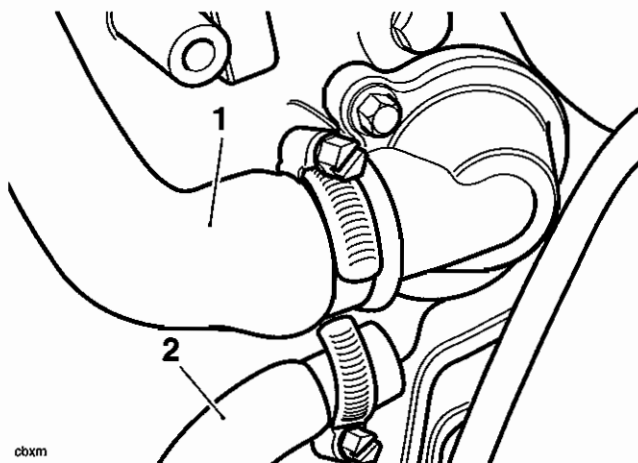

cbxm

1. Top hose
2. Bypass hose
5. Release the fixings securing the thermostat housing to the cylinder head.
6. Withdraw the housing and collect the thermostat.

Cooling

Inspection

1. Inspect the thermostat at room temperature. If the valve is open, the thermostat must be replaced.
2. To check the valve opening temperature, suspend the thermostat in a container of water together with a thermometer. Raise the temperature of the water until the thermostat opens. The thermostat should start to open at $88^{\circ}\text{C} \pm 5^{\circ}\text{C}$.
3. If the temperature at which thermostat opening takes place is incorrect, replace the thermostat.

Installation

1. Clean the mating surfaces of the cylinder head and thermostat housing.
2. Locate the thermostat into the head with the jiggle pin 15 degrees to the left of the fully upright position.

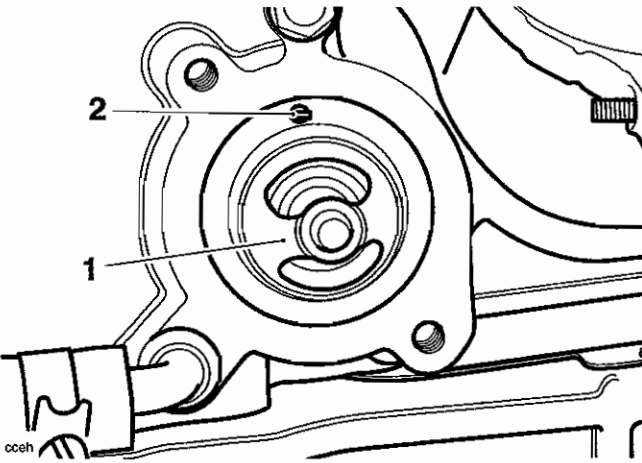

1. Thermostat
2. Jiggle pin

3. Rotate the thermostat until the jiggle pin is in the fully upright position.

Note:

- When correctly positioned, the thermostat will fit snugly into the head, the jiggle pin will be in the twelve O'clock position and the thermostat will not turn any further clockwise.

4. Position a new O-ring to the thermostat housing and seat into the groove.

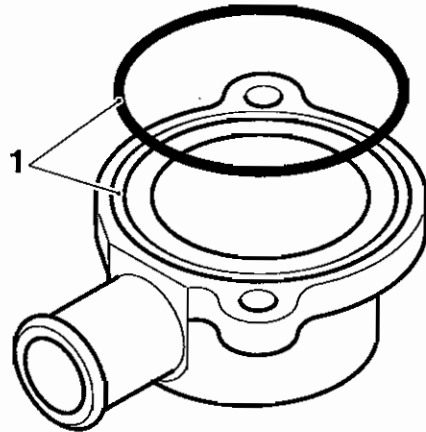

ceei

1. O-ring/groove

5. Locate the thermostat housing to the head, ensuring that the O-ring does not become detached. Tighten the fixings to **4 Nm**.
6. Reconnect the top hose and secure with the hose clip
7. Reconnect the battery, positive (red) lead first.
8. Refit the rider's seat.
9. Refill the cooling system as described on page 12.7.

Radiator

Removal



Before starting work, ensure the motorcycle is stabilised and adequately supported. This will help prevent it from falling and causing injury to the operator or damage to the motorcycle.

1. Remove the rider's seat.
2. Disconnect the battery, negative (black) lead first.



Do not remove the coolant pressure cap when the engine is hot. When the engine is hot, the coolant inside the radiator is hot and also under pressure. Contact with hot coolant will cause scalds and skin damage.

3. Drain the coolant as described on page 12.6.
4. Disconnect the top hose and bypass hose from the thermostat housing and head respectively.

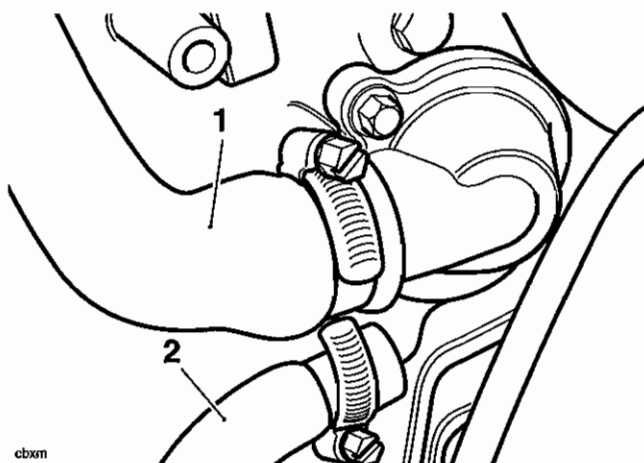

1. Top hose
2. Bypass hose

5. Disconnect the water pump hoses at the radiator.

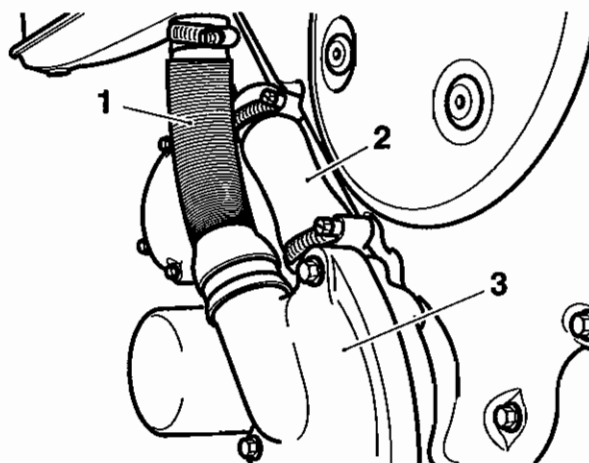

cbxd

1. Bottom radiator hose
2. Water pump outlet hose
3. Water pump
6. Remove both radiator side covers.

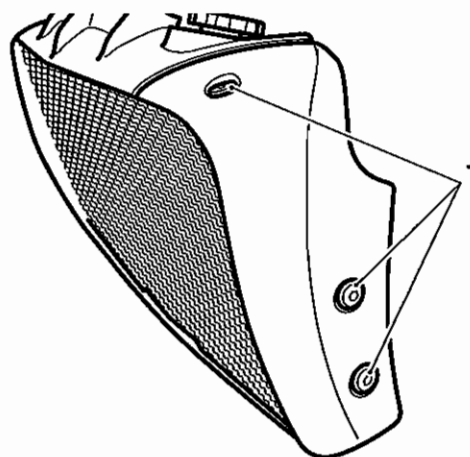

oocl

1. Side cover fixings
7. Remove the lower radiator cover.

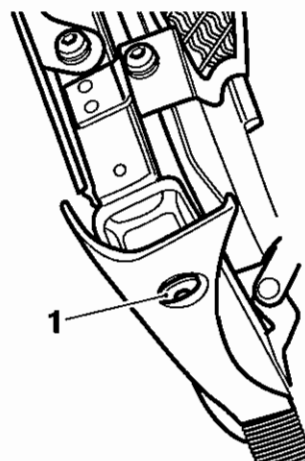

oocm

1. Lower cover fixing (left hand shown)

Cooling

8. Remove the radiator side grilles.

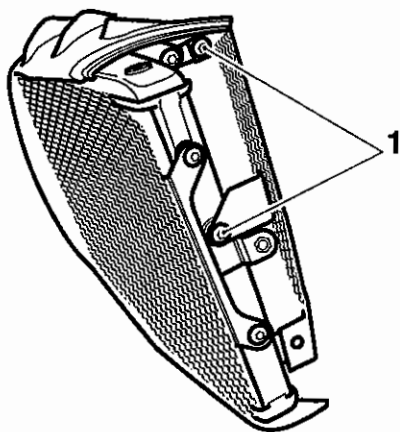

1. Side grille fixings

9. Remove the upper radiator cover.

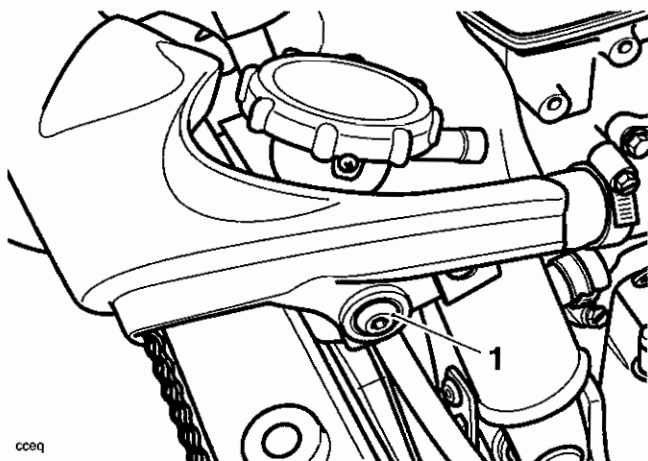

1. Upper radiator cover fixings (left hand shown)

10. Optionally, to prevent the possibility of damage, remove the radiator front grille.

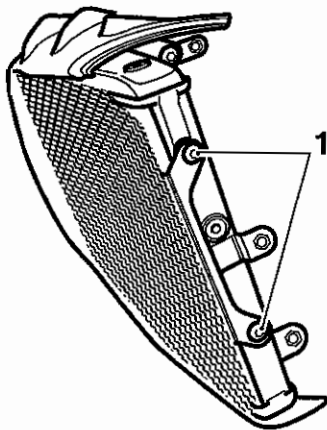

1. Front grille fixings

11. Release the radiator upper mounting bolts.

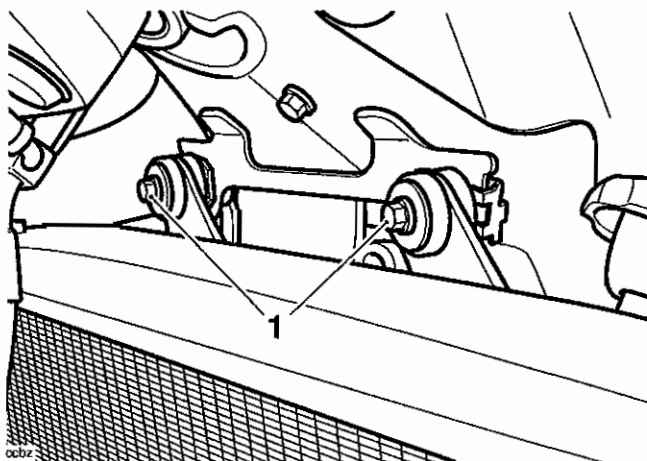

1. Radiator upper mounting bolts

12. Release the lower mounting bolt from the right hand side.
13. Disconnect the cooling fan.
14. Ease the radiator towards the right hand side of the motorcycle to dislodge it from its lower mounting stud.

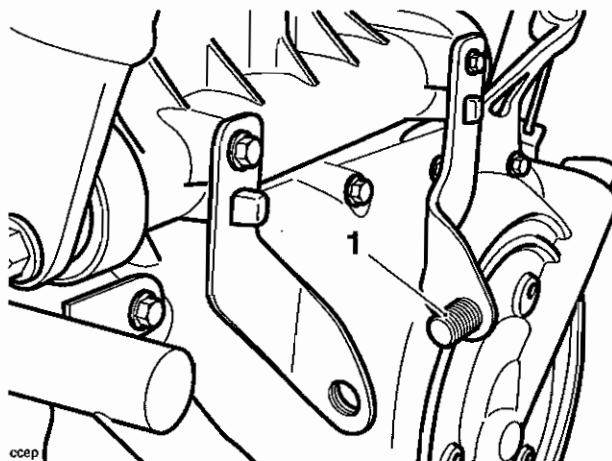

1. Radiator mounting stud

15. Remove the radiator.

Inspection

1. Check the radiator for stone damage.
2. Check the radiator core, for damage to fins or obstructions to air flow.
3. Repair any damage and clear all obstructions.



Caution

To avoid overheating and consequent engine damage, replace the radiator if the cores are blocked or if the fins are badly deformed or broken.

4. Check that the fan spins freely and without tight spots.
5. Check the fan blades for signs of heat distortion.
6. Check the fan cowl flaps for unobstructed operation and for splits and deformation of the flaps.

Installation

1. Align the radiator to the lower mounting stud, reconnect the cooling fan before fitting the upper and lower mounting bolts.
2. Tighten the mounting bolts to **9 Nm**.
3. Reconnect the top and bypass hoses to the thermostat housing and head respectively. Tighten the hose clips.
4. Reconnect the bottom hose to the radiator. Tighten the hose clip.
5. In the following order, refit the:
 - Front radiator grille if removed (fixing torque **7 Nm**).
 - Upper radiator cover (fixing torque **3 Nm**).
 - Side radiator grilles (side fixing torque **7 Nm**, upper fixing torque **3 Nm**).
 - Lower radiator cover (fixing torque **3 Nm**).
6. Reconnect the battery, positive (red) lead first.
7. Refit the rider's seat.
8. Refill the cooling system as described on page 12.7.
9. Refit the radiator side covers (fixing torque **9 Nm**).

This page intentionally left blank

13 Rear Suspension

Table of Contents

| | |
|---|------|
| Exploded View - Swinging Arm | 13.2 |
| Exploded View - Rear Suspension Units | 13.3 |
| Rear Suspension Units | 13.4 |
| Adjustment | 13.4 |
| Suggested Suspension Settings | 13.4 |
| Removal | 13.4 |
| Inspection | 13.5 |
| Installation | 13.5 |
| Swinging Arm and Drive Shaft | 13.5 |
| Removal | 13.5 |
| Inspection | 13.6 |
| Installation | 13.6 |
| Swinging Arm Bearings | 13.8 |
| Removal | 13.8 |
| Installation | 13.8 |

Rear Suspension

Exploded View - Swinging Arm

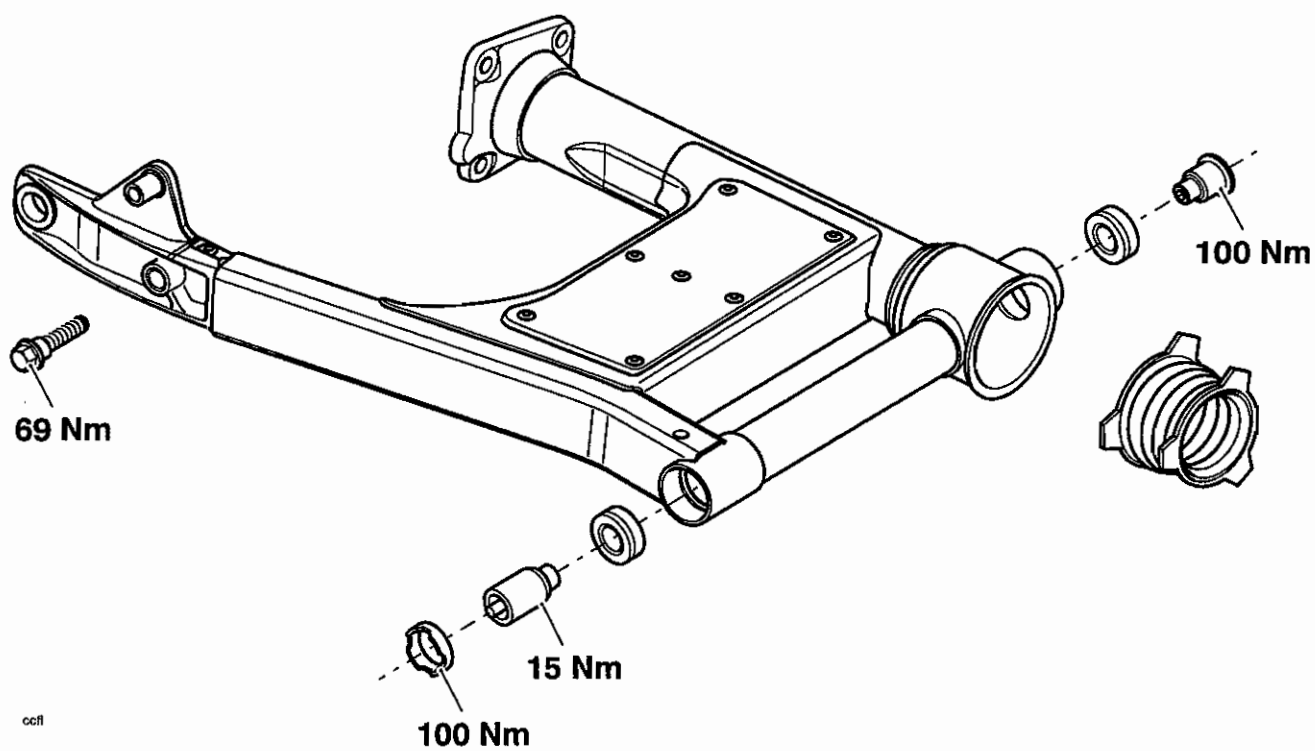

Exploded View - Rear Suspension Units

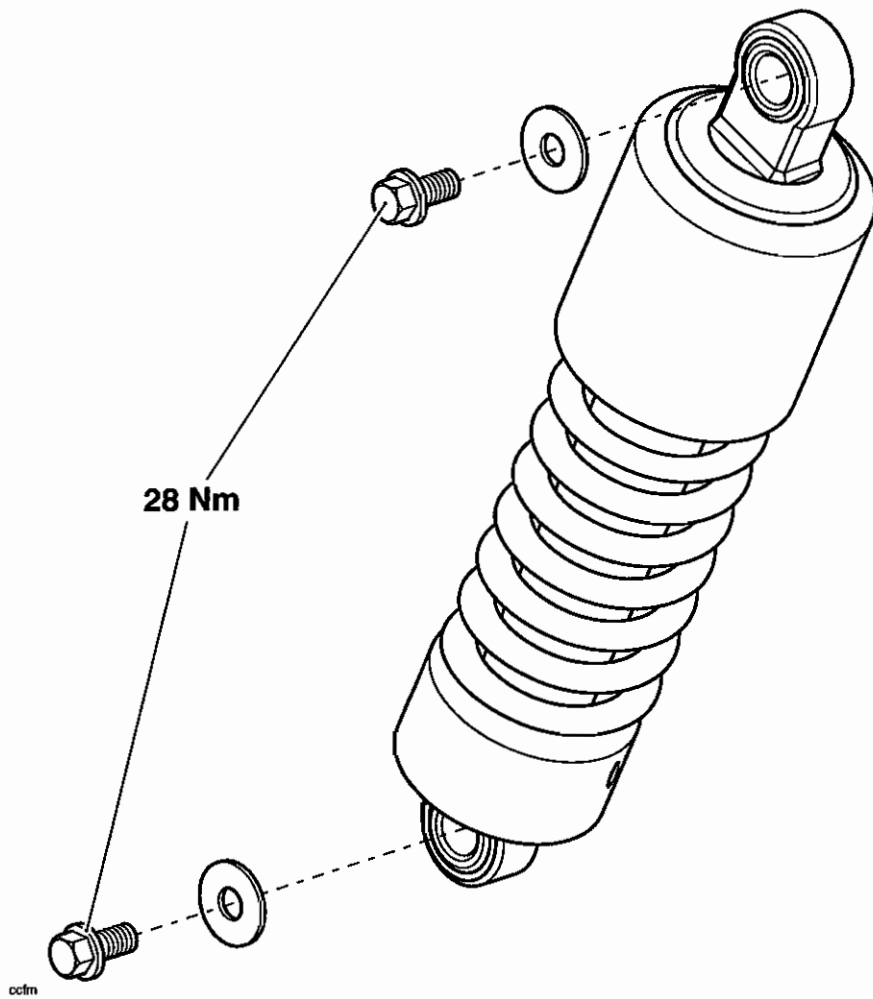

Rear Suspension

Rear Suspension Units

Adjustment

The rear suspension is adjustable for pre-load only.

To change the rear suspension spring pre-load setting, insert the adjustment tool supplied in the tool kit into the hole provided in the adjuster ring.

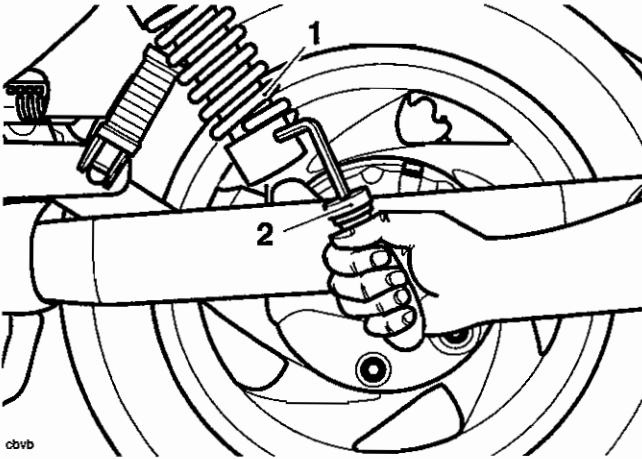

1. Rear Suspension Unit
2. Tool

Turn the adjuster ring clockwise to increase spring pre-load, and anti-clockwise to decrease spring pre-load. When delivered from the factory, the pre-load adjuster will be set at position 1.

Warning

Ensure that the adjusters are set to the same setting on both rear suspension units. Settings that vary from left to right may affect handling and stability resulting in loss of motorcycle control, and an accident.

Suggested Suspension Settings

Adjuster settings are counted from one with position one being with the adjuster turned fully anti-clockwise. There are five positions in total. Position one gives the minimum amount of spring pre-load.

| Riding Condition | Suspension Preload Setting |
|------------------------------|----------------------------|
| Rider only | Position 1 |
| Rider and passenger | Position 2 |
| Rider, passenger and luggage | Position 5 |

Note:

- The details given in the table are to be used as a guide only where the rider and passenger each weigh 90 kg or less. Setting requirements should be increased for heavier riders and passengers and according to personal preferences.

Removal

Warning

Before starting work, ensure the motorcycle is stabilised and adequately supported. This will help prevent it from falling and causing injury to the operator or damage to the motorcycle.

1. Raise and support the motorcycle so that the rear wheel is clear of the ground.

Note:

- If both suspension units are to be removed, place a block beneath the rear wheel to prevent it dropping when the second unit is removed.
2. Slacken and remove the upper and lower mounting bolts and washers then remove the suspension unit from its mounting spigots.

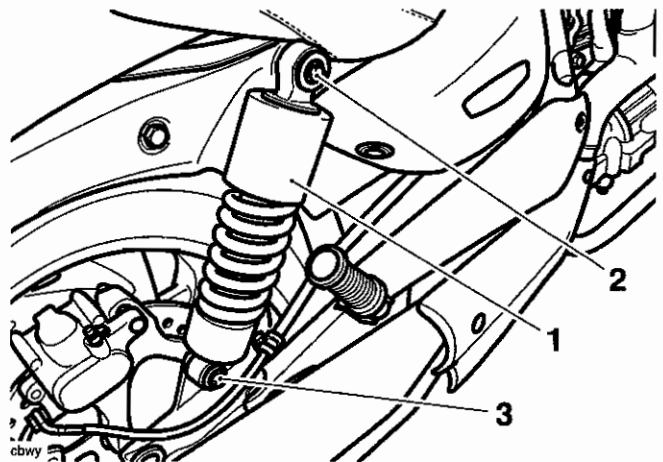

1. Rear suspension unit
2. Upper mounting bolts
3. Lower mounting bolts

3. Repeat operations 1 and 2 for the other rear suspension unit (if required).
4. Discard all mounting bolts removed.

Inspection

1. Remove all traces of dirt and inspect for damage/wear to the mountings and springs.
2. Inspect the unit closely for fluid leaks from all parts of the unit and for cracks and damage to the springs. If there is any damage, or any leaks are evident, both rear suspension units must be renewed as a matched pair.
3. Check the mounting rubbers for cracks and signs of elongation. Replace as necessary.

Warning

Always renew both rear suspension units as a pair, even if only one appears to be faulty. If only one suspension unit is replaced, the handling of the motorcycle could be adversely affected. This could result in an unsafe riding condition leading to a loss of motorcycle control and an accident.

Installation

1. Locate the suspension units to the mounting spigots, articulating the swinging arm until the distance between the upper and lower spigots allows the units to fit.
2. Fit the original washers to new mounting bolts. Install the bolts then tighten them to **28 Nm**.

Note:

- **The large washer is fitted to the top mounting, the smaller washer to the lower.**
3. Repeat operations 1 and 2 for the other rear suspension unit (if removed).
 4. Remove the wheel support (if fitted), lower the motorcycle to the ground and park it on the side stand.

Swinging Arm and Drive Shaft

Removal

Warning

Before starting work, ensure the motorcycle is stabilised and adequately supported. This will help prevent it from falling and causing injury to the operator or damage to the motorcycle.

Note:

- **The swinging arm may be removed with the exhaust system in place.**
1. Support the motorcycle so that the rear wheel is clear of the ground, with no weight on the swinging arm and suspension units.
 2. Remove the rear wheel as described on page 16.8.
 3. Remove the bevel box as described on page 6.4.
 4. Remove the rear suspension units as described on page 13.4.
 5. Detach the brake pipe clips from the right hand side of the swinging arm.

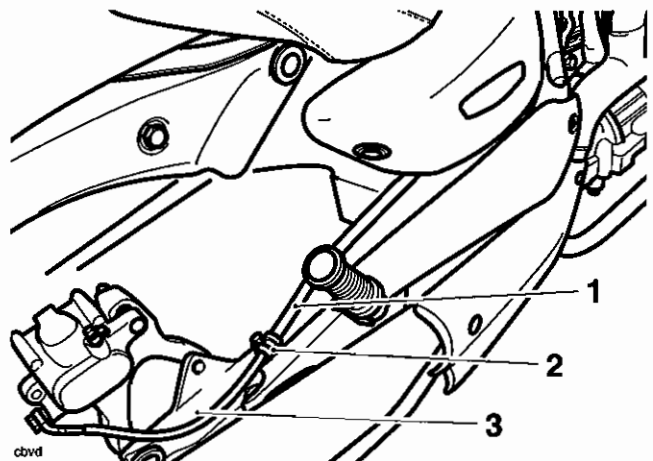

1. Brake pipe
2. Clips (rear of two shown)
3. Rearward clip location on swinging arm

Rear Suspension

- Using tool T3880062, release the locking ring on the right hand swinging arm pivot.

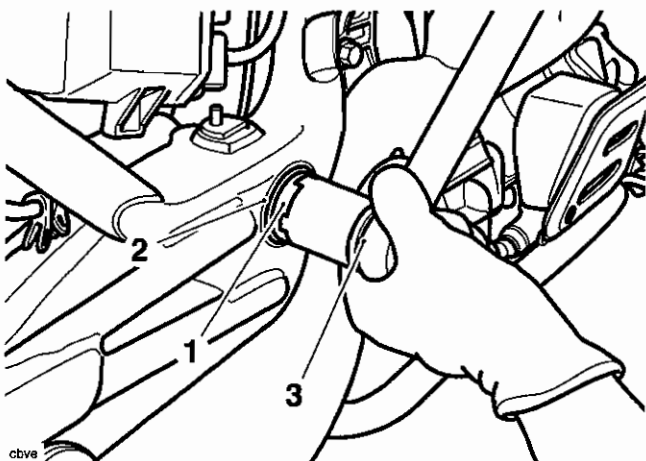

- Locking ring
- Swinging arm pivot
- Tool T3880062

- Support the arm before removing both swinging arm pivots completely.

Note:

- The left hand pivot will be very tight.
- Ease the swinging arm rearwards while detaching the drive shaft gaiter from the arm, leaving it attached to the transmission.
 - Manoeuvre the swinging arm from the frame, sliding it over the drive shaft (which runs inside it). Take care to not damage or detach the air box drain hoses during removal.

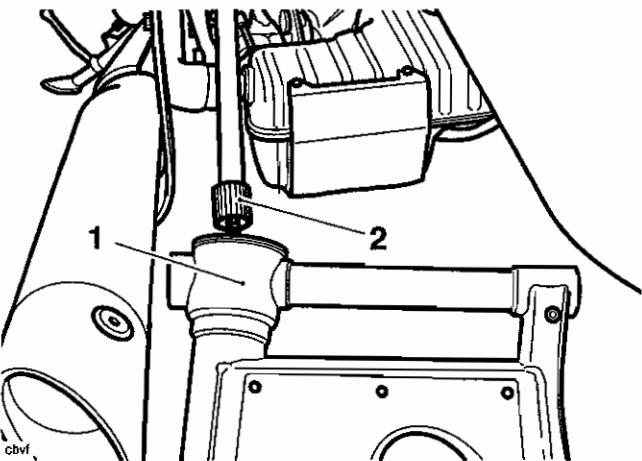

- Swinging arm
- Drive shaft

- If necessary, detach the drive shaft from the gearbox output shaft by pulling it gently towards the rear of the motorcycle.

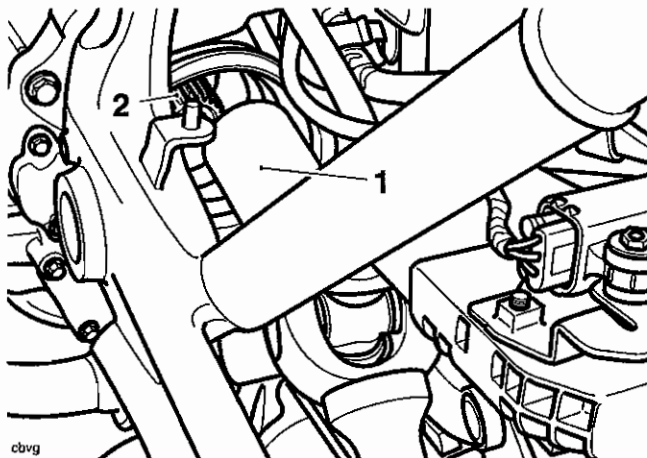

- Drive shaft
- Gearbox output shaft

Inspection

- Inspect the swinging arm bearings and bearing outer cups for damage, cracks and signs of the bearing rollers indenting the outer cup. Renew the bearings as described on page 13.7 if any damage is present in either bearing.
- Inspect the swinging arm pivots for damage and deformation. Renew as necessary.
- Inspect the drive shaft gaiter for splits and other damage. Replace as necessary.

Installation

Note:

- The drive shaft gaiter is attached to the swinging arm with super glue.
- Do not attempt to fit the swinging arm with the drive shaft sleeve in place. Fit the sleeve after first fitting the swinging arm to the frame.

- Grease the drive shaft splines with molybdenum disulphide grease.
- Locate and engage the drive shaft to the gearbox output shaft.

3. Thoroughly lubricate the swinging arm bearings with general purpose grease before positioning them to the swinging arm.

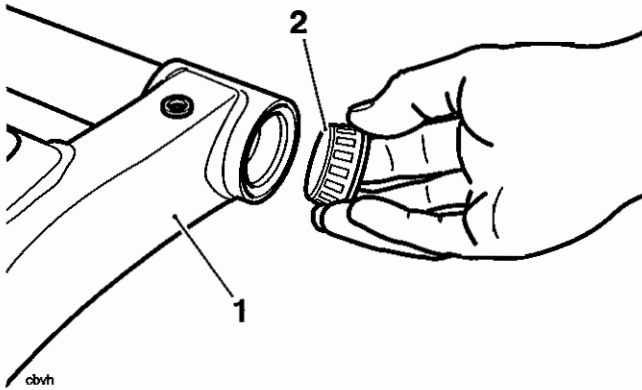

1. Swinging arm
2. Bearing

4. Position the swinging arm to the drive shaft and manoeuvre the arm along the drive shaft.

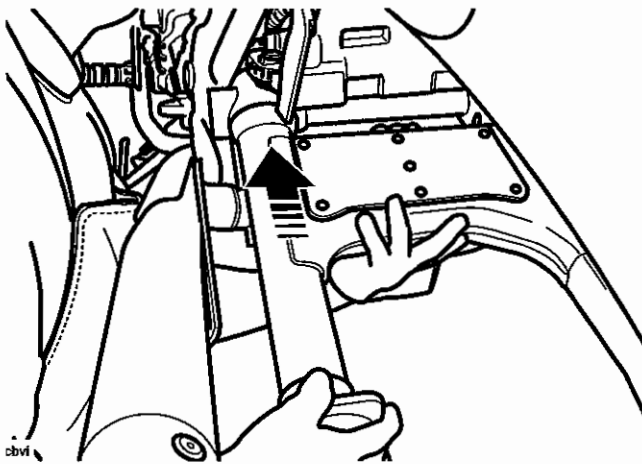

Fitting the swinging arm

5. Engage the threads of the swinging arm pivots to the frame.

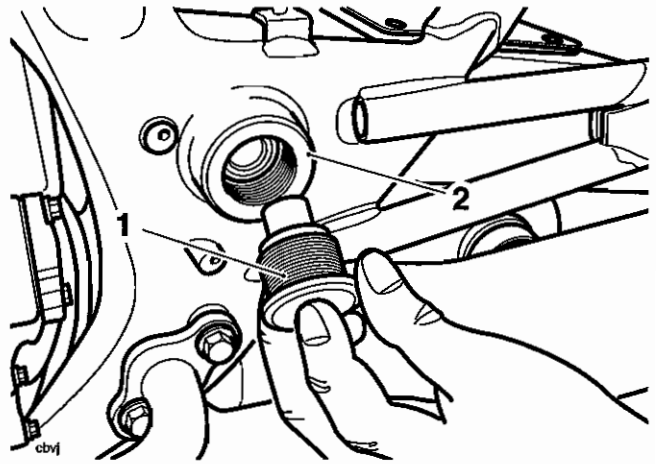

1. Pivots
2. Frame

6. Position the swinging arm bearings to the pivots.
7. Engage the pivots to the swinging arm bearings.
8. Tighten the left hand pivot to **100 Nm**.
9. Tighten the right hand pivot to **15 Nm**.
10. Tighten the right hand locking ring to **100 Nm** using tool T3880062.

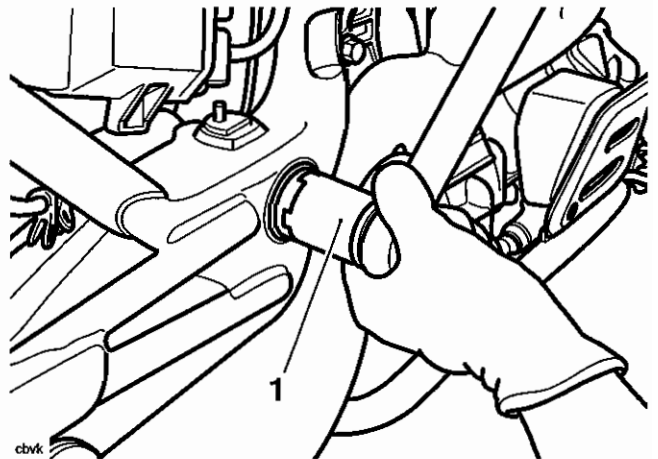

1. Tool T3880062

11. Apply a smear of general purpose grease to the drive shaft sleeve, inside and out.
12. Refit the drive shaft gaiter to the swinging arm and crankcase. Ensure it is engaged throughout its entire circumference both ends.

Rear Suspension

13. Refit the drive shaft sleeve.

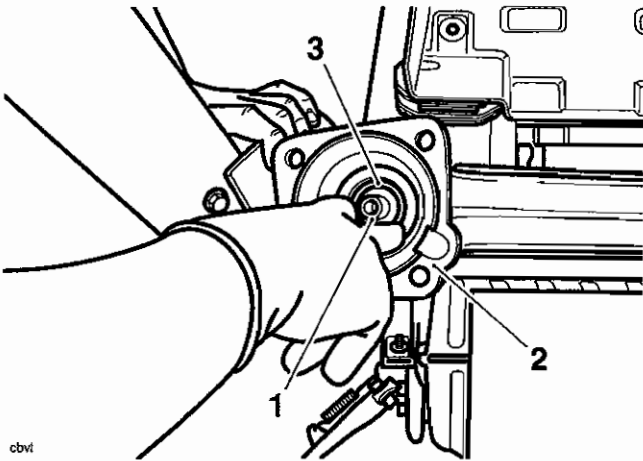

- 1. Drive shaft
- 2. Swinging arm
- 3. Sleeve

14. Align the two brake pipe clips to the right hand side of the swinging arm. Tighten the clip fixings to 7 Nm.

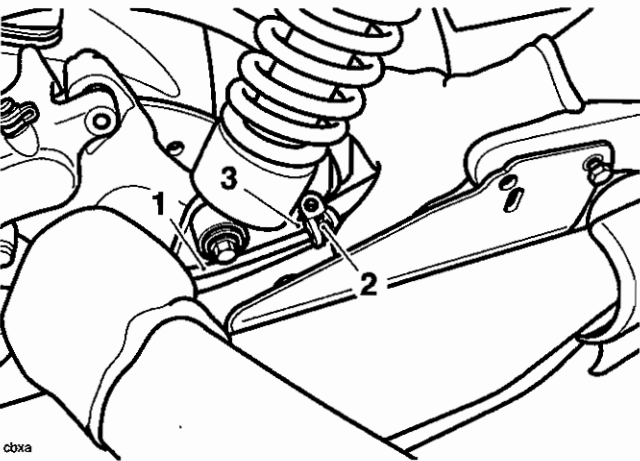

- 1. Brake pipe
- 2. Clips
- 3. Forward clip location on swinging arm

15. Refit the rear suspension units as described on page 13.5.
16. Refit the bevel box as described on page 6.4.
17. Refit the rear wheel as described on page 16.9.
18. Lower the motorcycle to the ground and park it on the side stand.
19. Pump the rear brake to position the rear brake pads.

Swinging Arm Bearings

Removal

Warning

Before starting work, ensure the motorcycle is stabilised and adequately supported. This will help prevent it from falling and causing injury to the operator or damage to the motorcycle.

1. Remove the swinging arm as described on page 13.5.

Note:

- It is necessary to remove the left hand bearing first.
2. Working from the opposite side of the arm to the bearing being removed, drift out the bearing and plug together.

Note:

- For access to the bearing cup during removal, it is recommended that the plug be deliberately deformed and removed first in order to see the rear face of the bearing cup.
3. Repeat for the second bearing cup.

Caution

Never use excessive force to drift the outer cup from the swinging arm or allow the cup to tip excessively. Either condition will damage the swinging arm.

4. To remove the right hand bearing, drift out the plug and bearing outer cup working from the left hand side of the swinging arm.

Installation

Note:

- Replacement bearings are supplied with the plug attached to the outer cup by means of adhesive. Do not separate these components, as it is not necessary to do so for installation. The plug is not an interference fit in the swinging arm.
1. Thoroughly clean all debris and dirt from the two bearing locations in the swinging arm.

2. Press the new bearing outer cups and plugs into each side of the swinging arm using tool T3880064, until both are pressed fully up to their locating shoulders inside the arm.
3. Apply general purpose grease to both bearings before refitting the swinging arm as described on page 13.7.

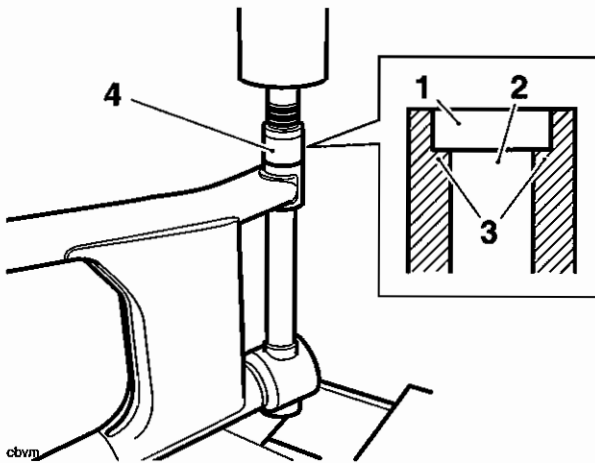

1. Bearing outer cup
2. Plug
3. Shoulder (arm shown in section)
4. Tool T3880064

This page intentionally left blank

14 Front Suspension

Table of Contents

| | |
|---|-------|
| Exploded View - Front Fork | 14-2 |
| Exploded View - Top and Bottom Yokes/Steering Head Bearings | 14-3 |
| Fork Inspection | 14-4 |
| Front Fork | 14-4 |
| Removal | 14-4 |
| Installation | 14-5 |
| Fork Oil Change | 14-5 |
| Oil refilling | 14-7 |
| Front Fork | 14-9 |
| Disassembly | 14-9 |
| Inspection | 14-12 |
| Assembly | 14-12 |
| Steering Head Bearing Check and Adjustment | 14-15 |
| Check | 14-15 |
| Adjustment | 14-15 |
| Bottom Yoke and Headstock Bearings | 14-17 |
| Yoke Removal | 14-17 |
| Bearing removal | 14-17 |
| Installation | 14-18 |

Front Suspension

Exploded View - Front Fork

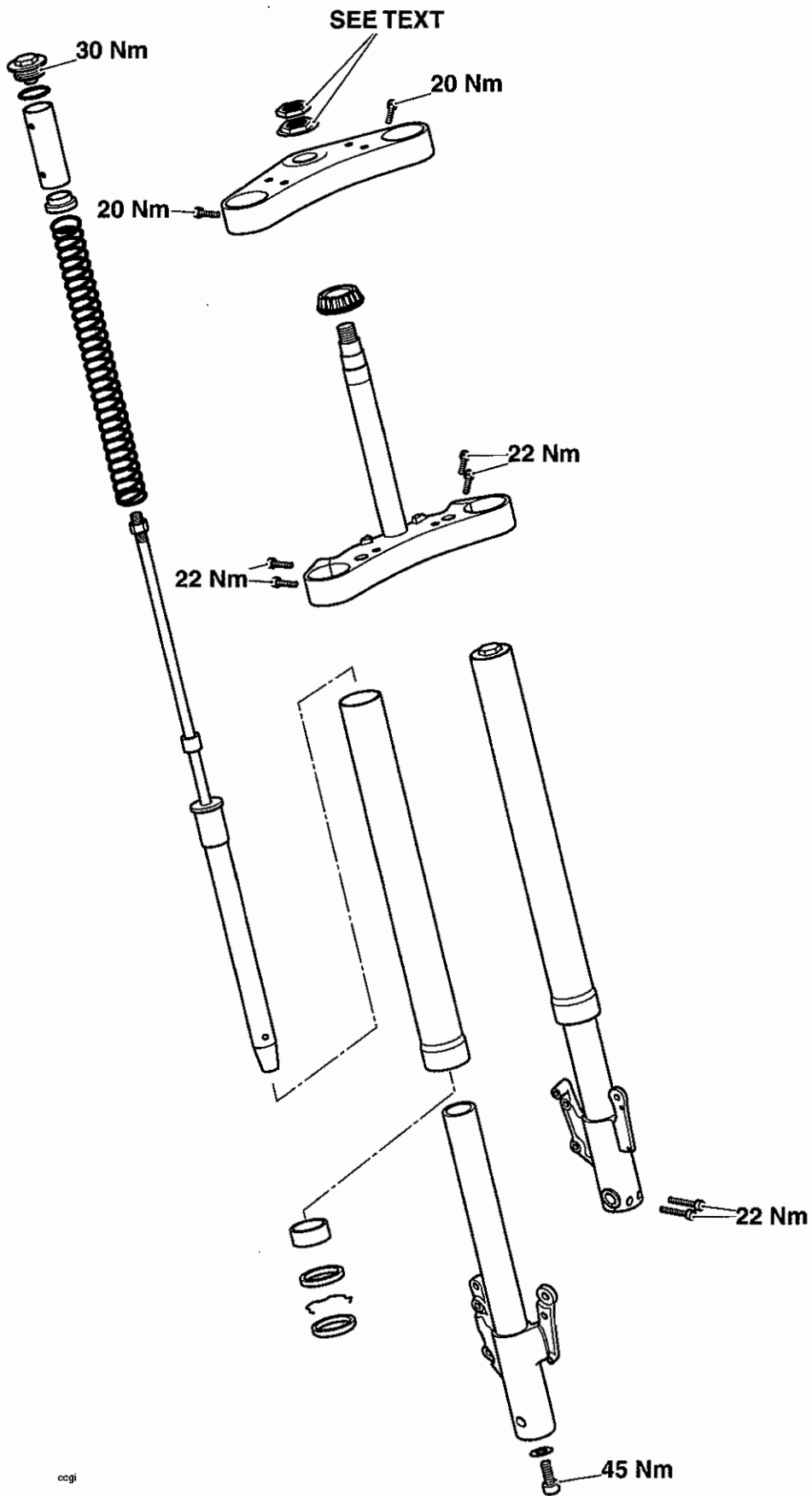

Exploded View - Top and Bottom Yokes/Steering Head Bearings

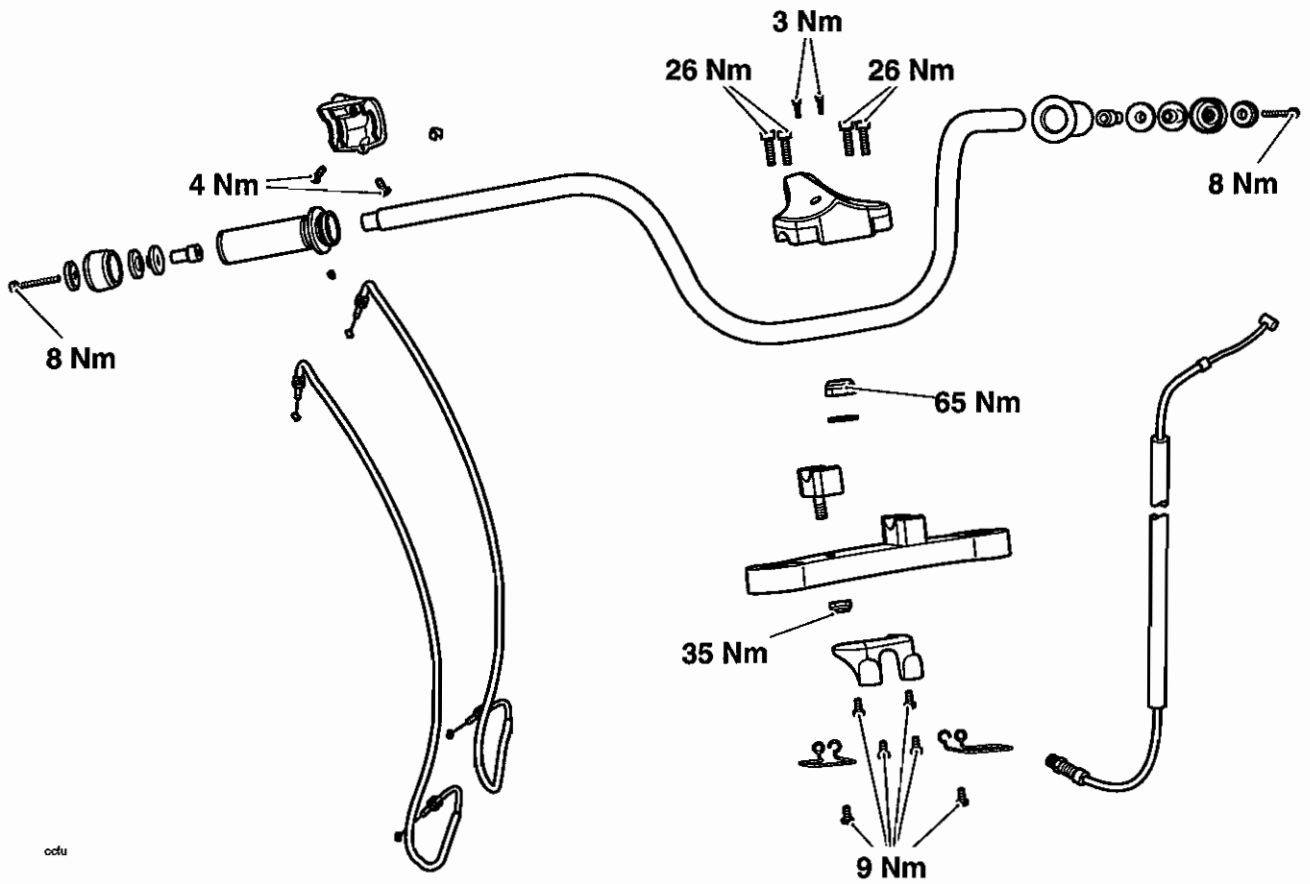

Front Suspension

Fork Inspection

Examine each fork for any sign of damage, scratching of the slider surface, or for oil leaks.

If any damage or oil leakage is found consult an authorised Triumph dealer.

Check that the forks operate smoothly as follows:

Position the motorcycle on level ground.

While holding the handlebars and applying the front brake, pump the forks up and down several times.

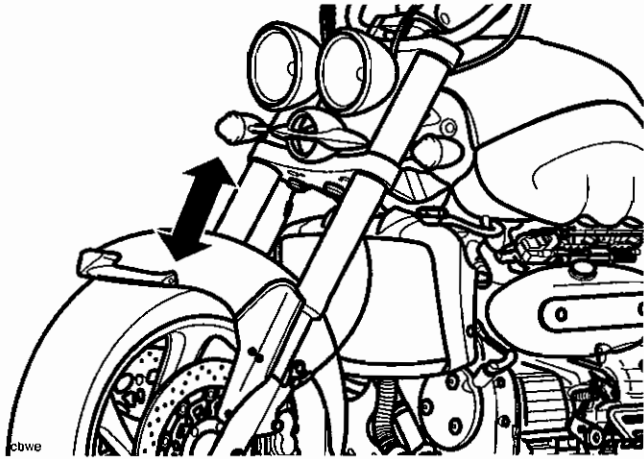

Inspecting forks

If roughness or excessive stiffness is detected, consult your authorised Triumph dealer.

Warning

Riding the motorcycle with defective or damaged suspension is dangerous and may lead to loss of motorcycle control and an accident.

Front Fork

Removal

Warning

Before starting work, ensure the motorcycle is stabilised and adequately supported. This will help prevent it from falling and causing injury to the operator or damage to the motorcycle.

1. Raise and support the front of the motorcycle.
2. Remove the front wheel as described on page 16.6.
3. Detach and support the front brake calipers.

Warning

Never allow the brake calipers to hang on the brake hoses as this may damage the hoses. A damaged brake hose can cause a reduction in braking efficiency leading to loss of motorcycle control and an accident.

4. Remove the front mudguard as described on page 17.10.
5. Slacken the top yoke clamp bolts.

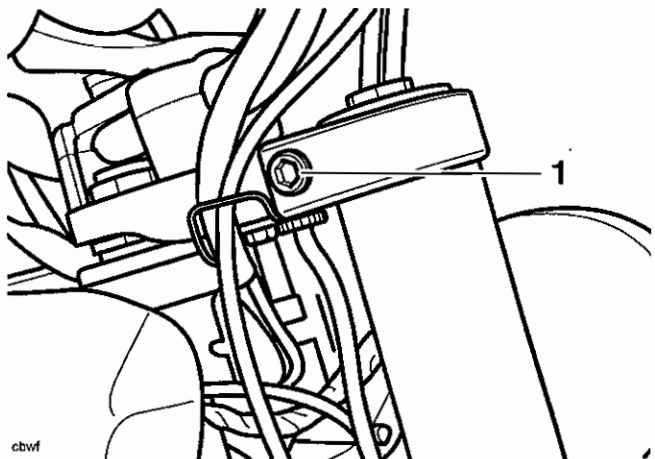

1. Top yoke clamp bolt

Caution

Care must be taken when removing the forks, to ensure that the outer surfaces do not become scratched.

- Slacken the bottom yoke clamp bolts and slide the forks out of the yokes.

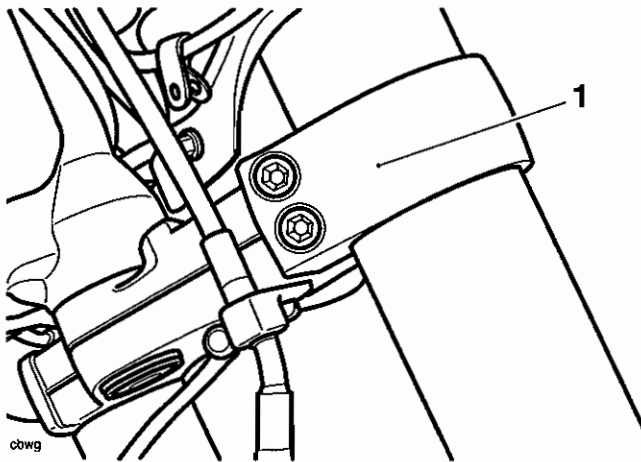

1. Bottom yoke clamp

Installation

- Position the fork within the yokes so that the lip of the outer tube is flush with the upper surface of the top yoke.

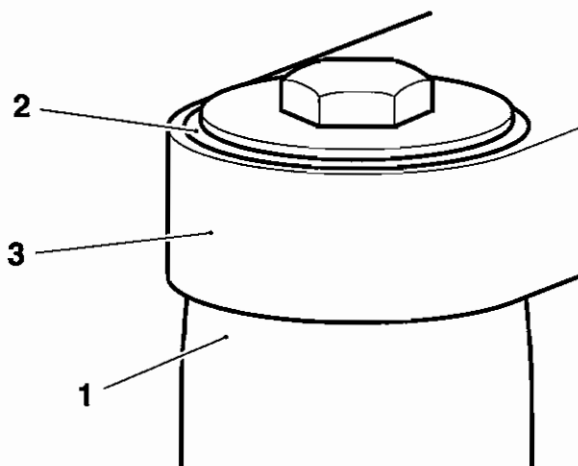

- Outer tube
- Outer tube lip
- Top yoke

- Tighten the bottom yoke clamp bolts to **22 Nm**.
- Tighten the top yoke clamp bolt to **27 Nm**.
- Refit the front mudguard as described on page 17.11.
- Install the front wheel as described on page 16.7.
- Refit the front brake calipers, tightening the bolts to **40 Nm**.
- Lower the motorcycle to the ground and park it on the side stand.

Fork Oil Change



Warning
Before starting work, ensure the motorcycle is stabilised and adequately supported. This will help prevent it from falling and causing injury to the operator or damage to the motorcycle.

- Remove the forks as described on page 14.4.
- Secure the fork in a soft jawed vice, gently clamping it on the caliper mounting.

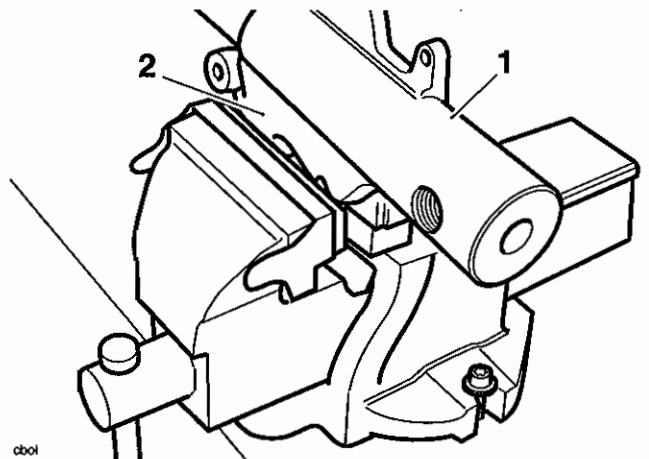

- Fork
- Caliper mounting



Warning
Clamping the fork by any point other than the caliper mounting may damage the fork. A damaged fork is dangerous and can cause instability leading to loss of motorcycle control and an accident.



Caution
When securing the fork in a vice, take great care not to over-tighten the vice, as this will cause damage to the fork.

- Hold the outer tube by hand to prevent it from turning, then unscrew the top cap from the outer tube.

Note:

- The top cap is not under spring tension and will not spring upwards when the threads disengage.

- Remove the fork from the vice and have an assistant stand it upright on the floor.
- Allow the outer tube to fall into the inner.

Front Suspension

- Fit tool T3880067 over the top cap. Position the two adjustable arms to the holes in the spring spacer. Screw in the arms until they positively engage in the spring spacer holes.

Warning

While compressing the fork spring and while the spring holder is in place always wear protective equipment for the face and eyes and never stand directly above or look directly down onto the fork. If the spring compressor or holder should dislodge or detach, the resulting release of spring tension could cause parts to fly off resulting in injury to the user.

- Using tool T3880067, manually compress the fork spring and insert the spring holder below the damper locknut.

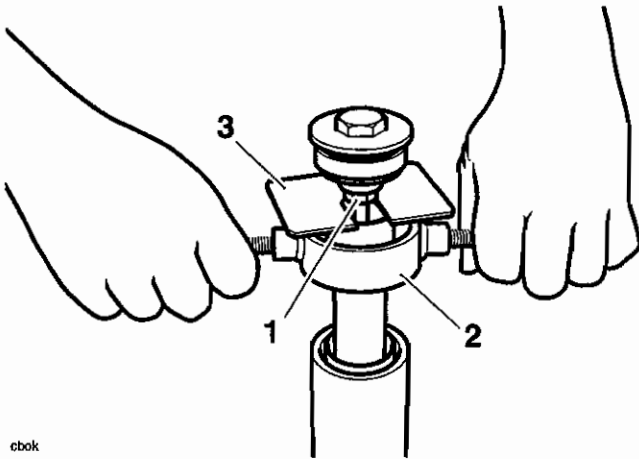

cbok

- Damper locknut
- Tool T3880067
- Spring holder

- Slacken the locknut, unscrew and remove the top cap. Recompress the fork spring to remove the holder.

Warning

While recompressing the fork spring and while the spring holder is in place always wear protective equipment for the face and eyes and never stand directly above or look directly down onto the fork. If the spring compressor or holder should dislodge or detach, the resulting release of spring tension could cause parts to fly off resulting in injury to the user.

- Remove the spacer, spring cap and spring.

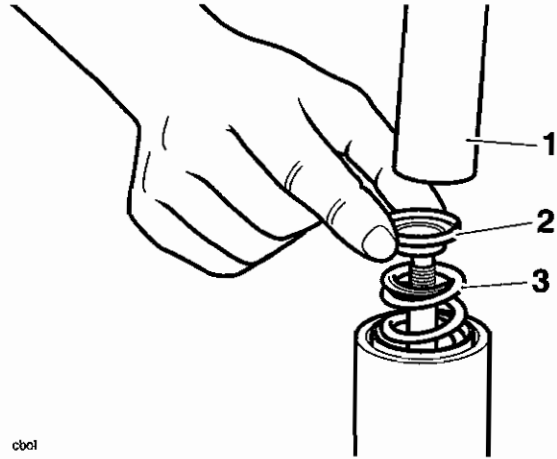

cbol

- Spacer
- Spring cap
- Spring

Note:

- At this stage of strip-down, the inner and outer tubes can become separated if they are not held together.
- Holding both the outer and inner tubes together, invert the fork and pour out the fork oil into a suitable container. Pump the damper rod to remove all oil.

Oil refilling

The oil level specified for Rocket III forks is 89 mm from the upper surface of the fork outer tube, with the fork fully compressed.

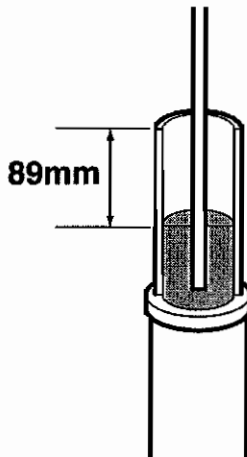

cbyf

Fork oil level (fork fully compressed)

1. Fill the fork with SAE 5w (or Kayaba KHL15-10 fork oil until the oil level is slightly above the recommended level. Alternatively add 667cc of oil if filling a completely empty fork.
2. Pump the fork assembly and damper several times to expel any trapped air then fully compress the fork and support it in an upright position. Leave the fork for a few minutes to allow the oil level to stabilise.
3. Set the scale on tool 3880160-T0301 to the specified level (dimension A below).

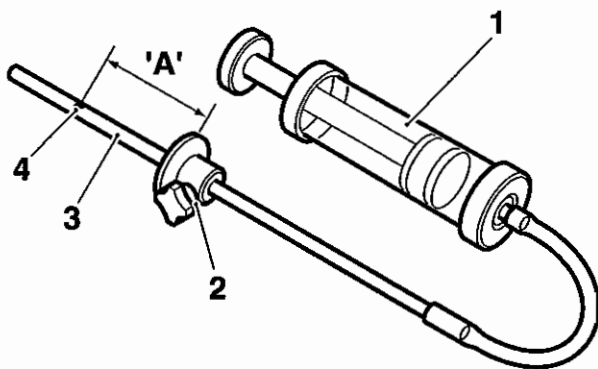

cbyg

1. Tool 3880160-T0301
2. Adjuster plate
3. Scale area
4. Hole (zero position)

Note:

- **Zero level on the tool is set at the small exit hole in the side of the scale tube, NOT AT THE END TIP. Do not attempt to block this side-hole, as this will cause the final fluid level to be incorrect.**
4. Insert the scale end of the tool into the fork inner tube.
 5. Hold the tool adjuster plate level with the upper surface of the fork outer tube and draw fluid into the syringe until fluid flow ceases (empty the syringe if the body becomes full before fluid flow stops).
 6. The fluid level in the fork is now set to the height set on the tool scale. Check the tool scale setting and repeat the process if incorrectly set.

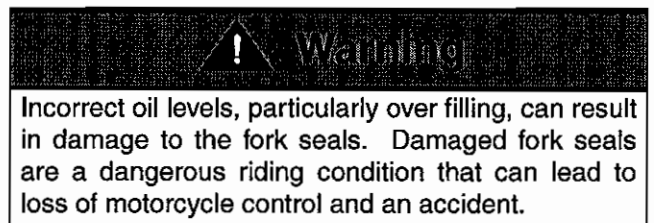

7. Position the fork assembly as for compression of the fork spring during strip down.
8. Insert the fork spring and spring cap to the outer tube.
9. Attach tool 3880085-T0301 to the threads of the damper rod and pull the damper upwards.

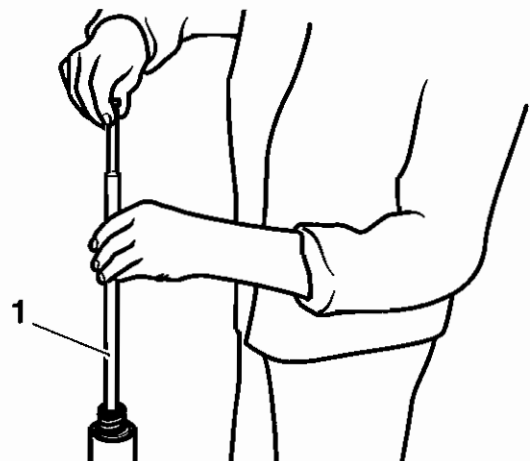

cbov

1. Tool 3880085-T0301
10. Refit the spring spacer.

Front Suspension

Warning

While recompressing the fork spring and while the spring holder is in place always wear protective equipment for the face and eyes and never stand directly above or look directly down onto the fork. If the spring compressor or holder should dislodge or detach, the resulting release of spring tension could cause parts to fly off resulting in injury to the user.

11. Refit tool T3880067 as previously described, compress the fork spring and refit the spring holder.

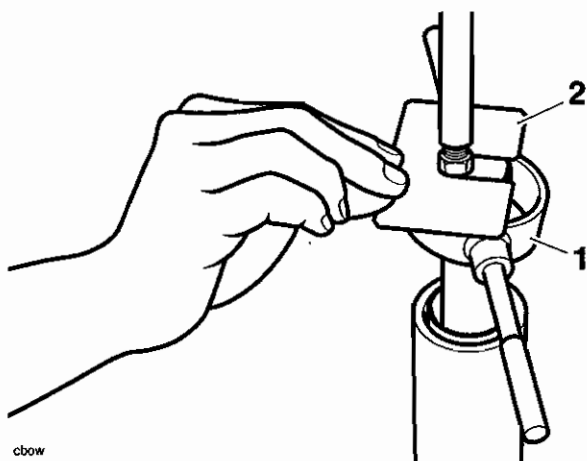

1. Tool T3880067
2. Spring holder

12. Refit the damping rod locknut leaving 15.5mm of thread and rod exposed above the nut.

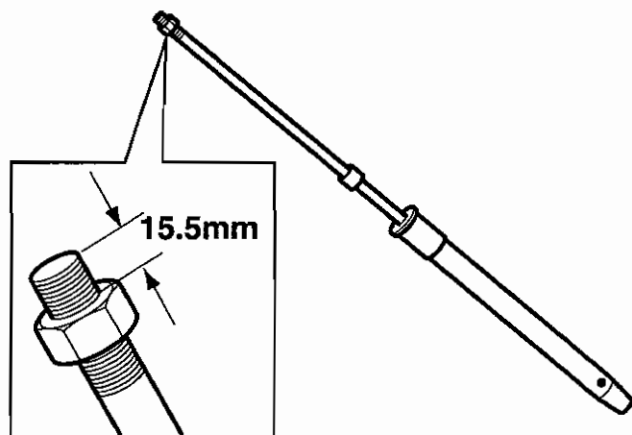

13. Refit the top cap to the damper rod.
14. Hold the top cap while tightening the damper rod locknut to **16 Nm**.

Warning

While recompressing the fork spring and while the spring holder is in place always wear protective equipment for the face and eyes and never stand directly above or look directly down onto the fork. If the spring compressor or holder should dislodge or detach, the resulting release of spring tension could cause parts to fly off resulting in injury to the user.

15. Recompress the spring to remove the spring holder.
16. Lubricate the O-ring on the top cap with a smear of fork oil then screw the top cap fully into the inner tube.
17. Tighten the top cap to **30 Nm**.

Note:

- It is much easier to tighten the top cap when the fork is securely clamped in the bottom yoke.

Front Fork



Before starting work, ensure the motorcycle is stabilised and adequately supported. This will help prevent it from falling and causing injury to the operator or damage to the motorcycle.

Disassembly

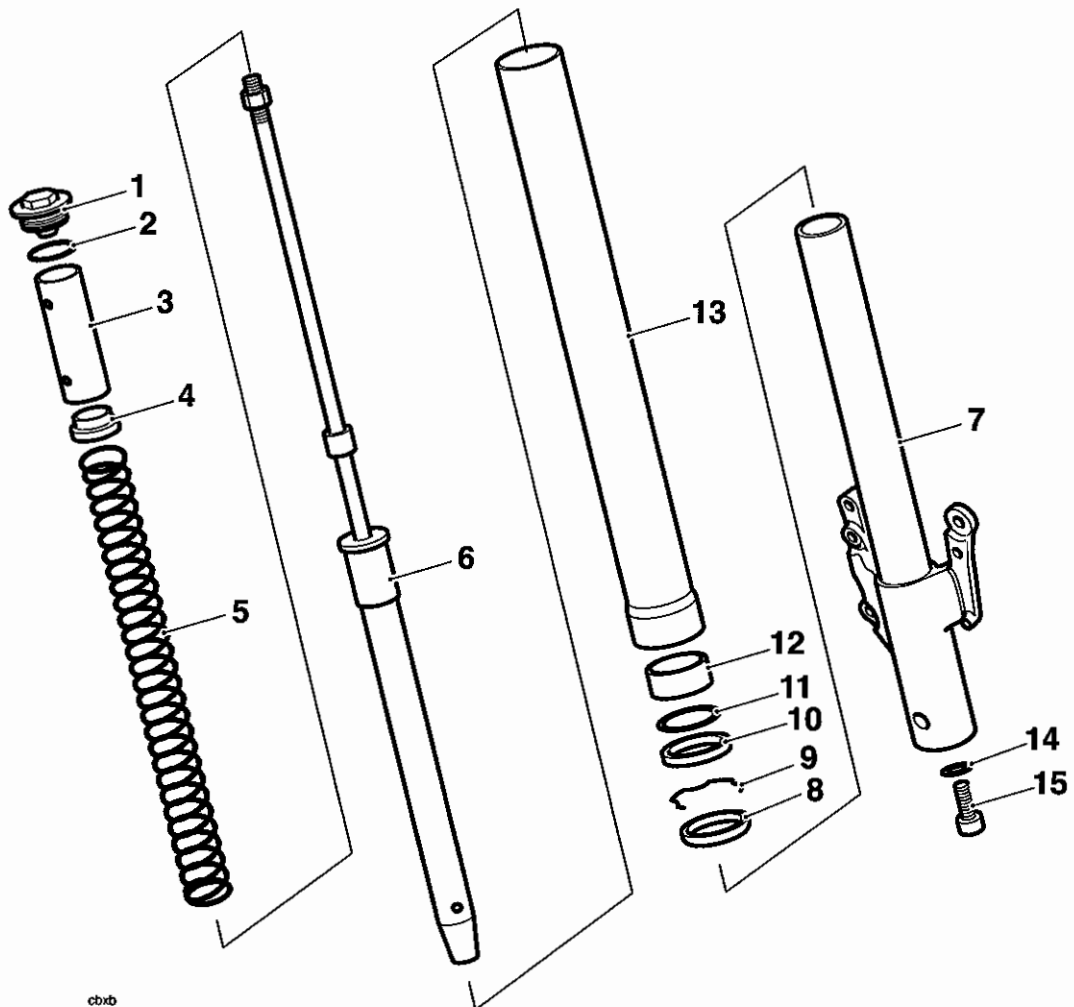

Fork components

- 1. Top cap
- 2. O-ring
- 3. Spacer
- 4. Spring seat
- 5. Spring
- 6. Damper rod/cylinder
- 7. Inner tube
- 8. Dust seal

- 9. Circlip
- 10. Oil seal
- 11. Washer
- 12. Bush
- 13. Outer tube
- 14. Sealing washer
- 15. Damper rod bolt

Front Suspension

1. Remove the forks as described on page 14.9.
2. Secure the fork in a soft jawed vice, gently clamping it on the caliper mounting.

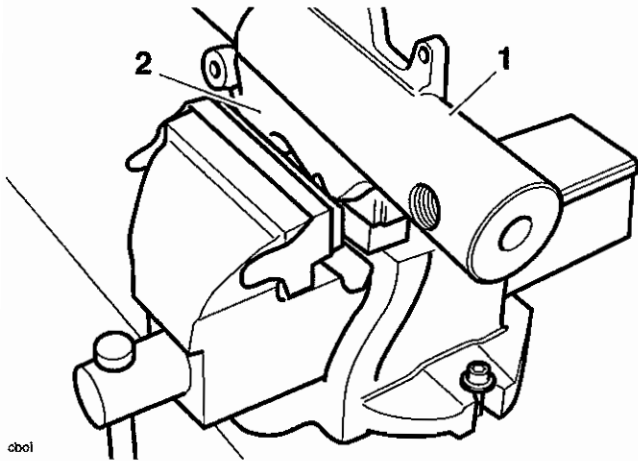

- cbol
1. Fork
 2. Caliper mounting

Warning

Clamping the fork by any point other than the caliper mounting may damage the fork. A damaged fork is dangerous and can cause instability leading to loss of motorcycle control and an accident.

Caution

When securing the fork in a vice, take great care not to over-tighten the vice, as this will cause damage to the fork.

Note:

- The fork seals can be renewed without removal of the damping cylinder. Unless removal of the damping cylinder is necessary, omit items 3, 11 and 12.

3. Unscrew the top cap from the outer tube.

Note:

- The top cap is not under spring tension.

4. Remove the fork from the vice and have an assistant stand it upright on the floor.
5. Fit tool T3880067 over the top cap. Position the two adjustable arms to the holes in the spring spacer. Screw in the arms until they positively engage in the spring spacer holes.

Warning

While compressing the fork spring and while the spring holder is in place always wear protective equipment for the face and eyes and never stand directly above or look directly down onto the fork. If the spring compressor or holder should dislodge or detach, the resulting release of spring tension could cause parts to fly off resulting in injury to the user.

6. Using tool T3880067, manually compress the fork spring and insert the spring holder below the damper locknut.

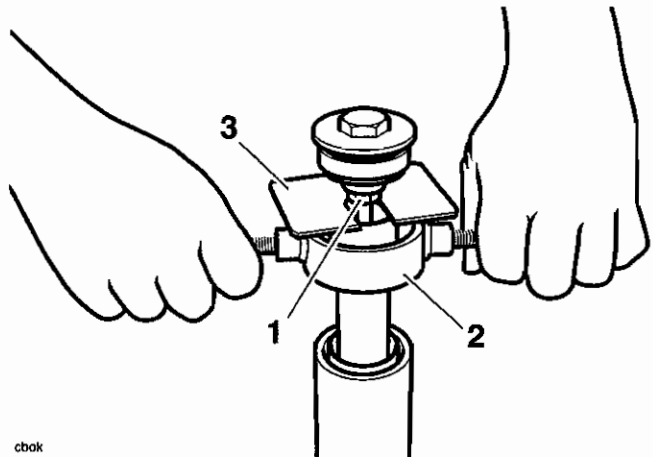

- cbok
1. Damper locknut
 2. Tool T3880067
 3. Spring holder

7. Slacken the locknut, unscrew and remove the top cap. Recompress the fork spring to remove the holder.

Warning

While recompressing the fork spring and while the spring holder is in place always wear protective equipment for the face and eyes and never stand directly above or look directly down onto the fork. If the spring compressor or holder should dislodge or detach, the resulting release of spring tension could cause parts to fly off resulting in injury to the user.

8. Remove the spacer, spring cap and spring.

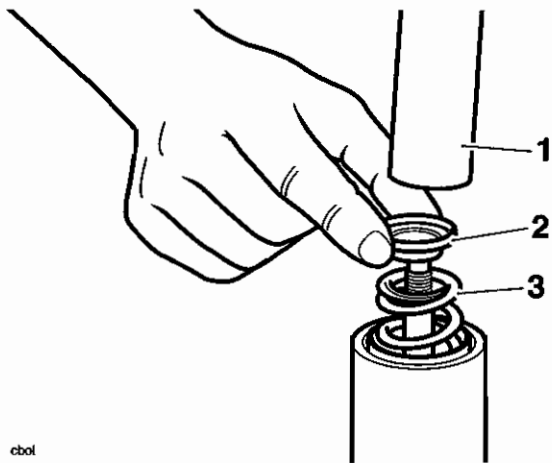

cbol

- 1. Spacer
- 2. Spring cap
- 3. Spring

- 9. Holding both the outer and inner tubes together, invert the fork and pour out the fork oil into a suitable container. Pump the damper rod to remove all oil.
- 10. Return the fork to the vice, clamping it as before.
- 11. Separate the inner and outer tubes leaving the dust and oil seals in place in the outer tube.

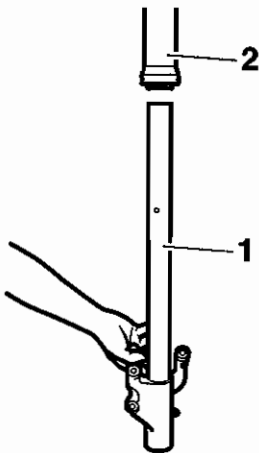

cbom

- 1. Inner tube
- 2. Outer tube

- 12. Remove the damper rod locknut then insert the square end of tool 3990090-T0301 over the damper rod and engage the square in the damping cylinder cup inside the fork. Hold the hexagonal end of the tool to prevent the cylinder from turning while removing the damper bolt from the bottom of the fork.

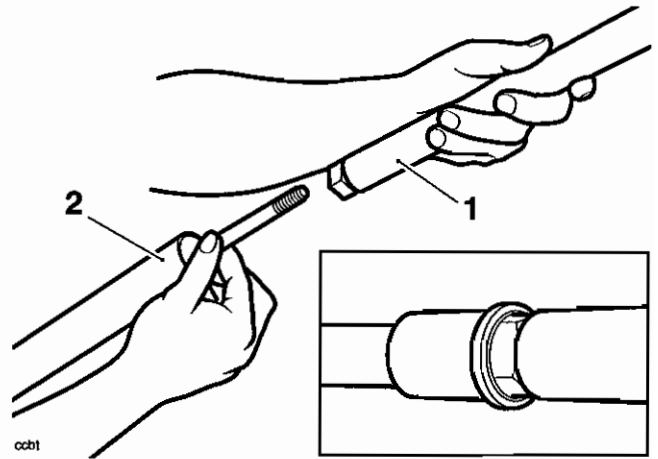

ccbt

- 1. Tool 3880090-T0301
- 2. Damping cylinder

- 13. Remove the tool, then the damping cylinder from the inner tube.

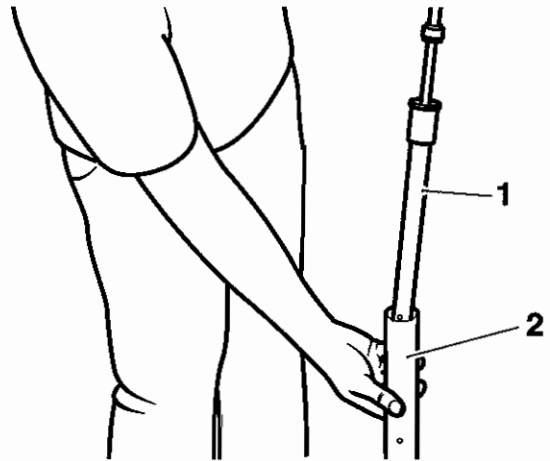

cbon

- 1. Damping cylinder
- 2. Inner tube

- 14. Using finger pressure, remove the dust seal from the outer tube.

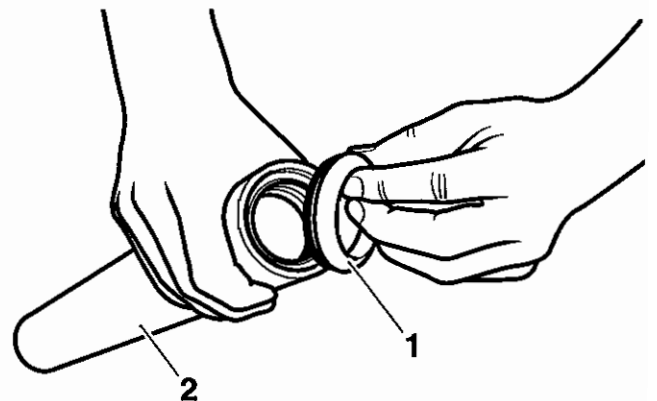

cboc

- 1. Dust seal
- 2. Outer tube

Front Suspension

15. Remove the circlip from above the seal.

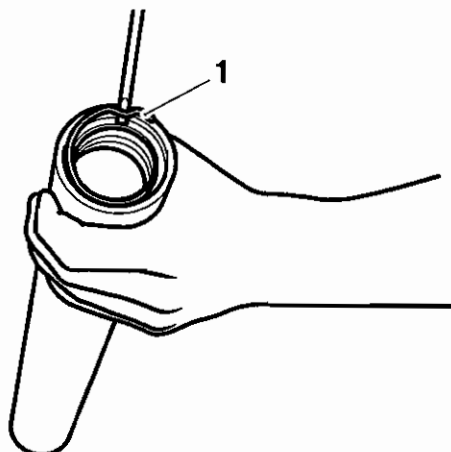

cbop

1. Circlip

16. Note the orientation of the seal lip then, using a soft-faced drift, remove the seal and collect the washer from below it.

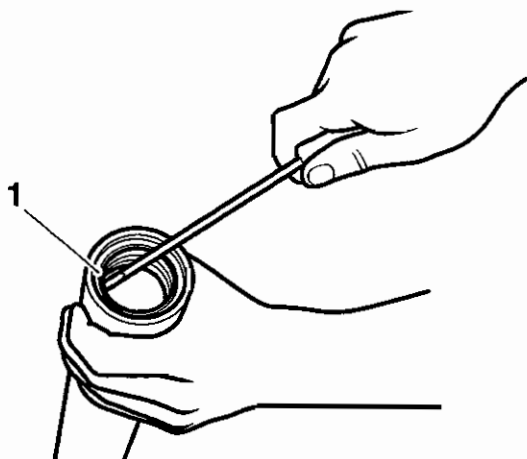

cbop

1. Seal removal

Inspection

1. Inspect the inner tube for stone chips, scoring, scratches, excessive wear and any other damage. Renew the inner tube if necessary.
2. Inspect the spring for damage, cracks and deformation. Renew the spring if necessary.
3. Inspect all bushes and seals for damage. Renew any damaged items if necessary.

Assembly

Warning

The front forks comprise many precision machined parts. Total cleanliness must be observed at all times and, assembly must take place in a dirt/dust-free environment. All parts must be washed in non-flammable solvent before assembly. Dirt ingress may cause damage to the fork parts, leading to, instability, loss of motorcycle control and an accident.

Note:

- If the damper has not been removed, omit operations 6 and 7.

1. Apply a smear of fork oil to the bushes and seals.
2. Fit the washer to the seal recess in the outer tube.

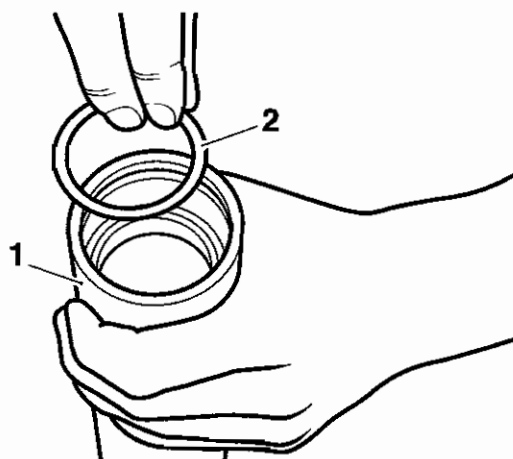

cbor

1. Outer tube
2. Washer

- Position the seal as noted prior to removal, then position it to the outer tube and drift into place using tool 3880080-T0301. Retain the seal with a new circlip.

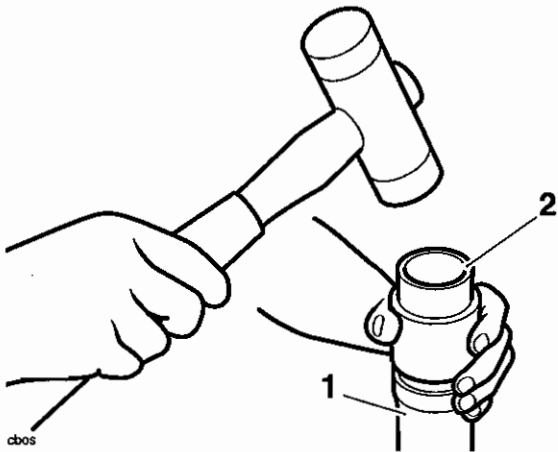

- Seal
- Tool 3880080-T0301
- Refit the dust seal, using finger pressure only.

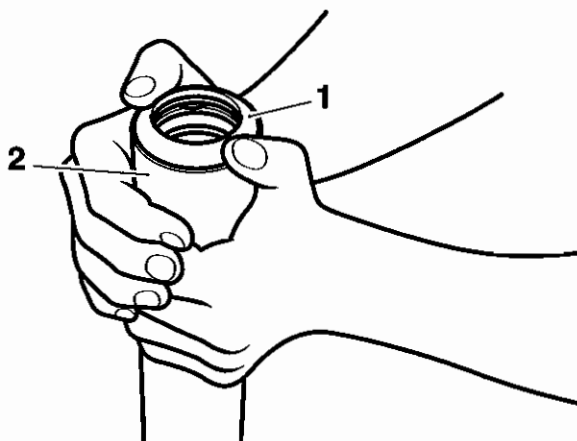

- Dust seal
- Outer tube

- Carefully fit the outer tube to the inner ensuring that the oil and dust seal lips do not become damaged.

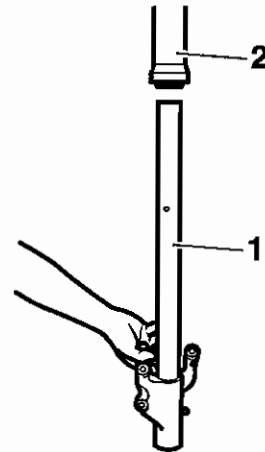

cbom

- Inner tube
- Outer tube
- Fit the damper to the inner tube and engage tool 3880090-T0301 to the damper cup (as for removal).
- Clean the threads of the damping cylinder bolt and fit a new sealing washer. Apply a drop of three-bond 1342 to the threads then install the bolt. Prevent the cylinder from turning by holding the hexagonal end of tool 3880090-T0301 while tightening the damping cylinder bolt to **45 Nm**.

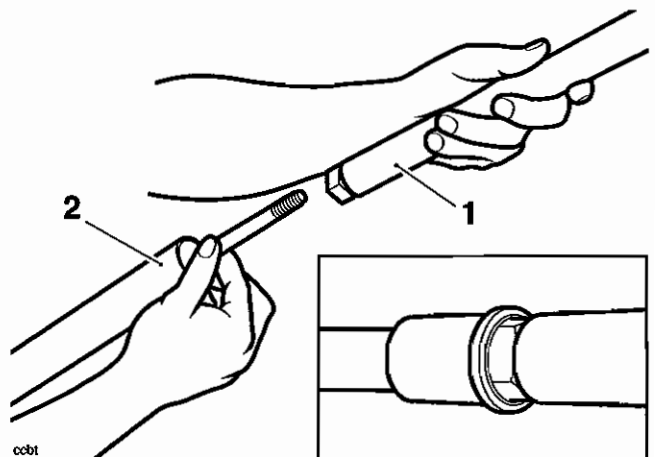

cbot

- Tool 3880090-T0301
- Cylinder

⚠ Caution

The damping rod locknut must be fitted with the flat side facing to the top of the fork. The slightly tapered side must face the fork spring.

Incorrect orientation may lead to a loosening of the locknut.

Front Suspension

8. Refit the damping rod locknut leaving 15.5mm of thread and rod exposed above the nut.

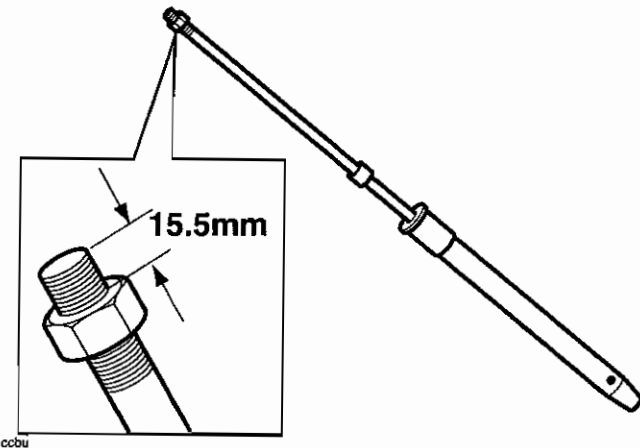

9. Fill the fork with oil as described on page 14.7.
10. Position the assembly as for compression of the fork spring.
11. Insert the fork spring and spring cap to the outer tube.
12. Attach tool 3880085-T0301 to the threads of the damper rod and pull the damper upwards.

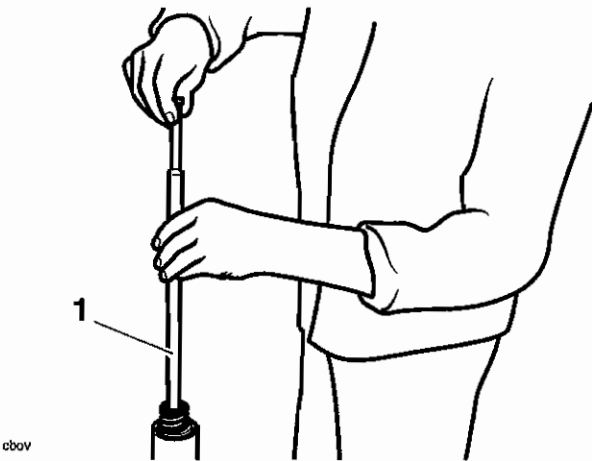

1. Tool 3880085-T0301

13. Refit the spring spacer.

Warning

While recompressing the fork spring and while the spring holder is in place always wear protective equipment for the face and eyes and never stand or look directly down onto the fork. If the spring compressor or holder should dislodge or detach, the resulting release of spring tension could cause parts to fly off resulting in injury to the user.

14. Refit tool T3880067 to the spring spacer, compress the fork spring and refit the spring holder.

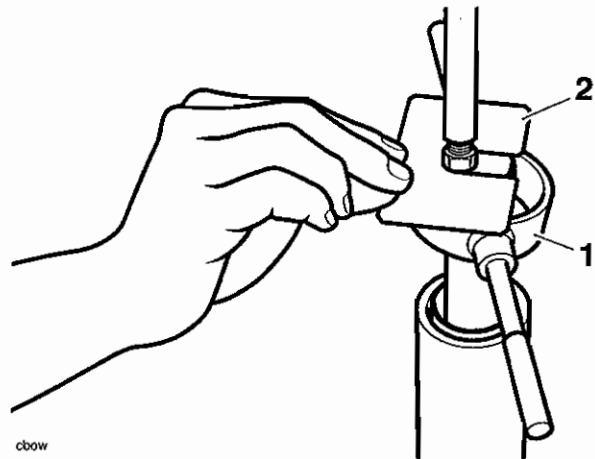

1. Tool T3880067

2. Spring holder

15. Refit the top cap to the damper rod
16. Hold the top cap while tightening the damper rod locknut to **16 Nm**.

Warning

While recompressing the fork spring and while the spring holder is in place always wear protective equipment for the face and eyes and never stand or look directly down onto the fork. If the spring compressor or holder should dislodge or detach, the resulting release of spring tension could cause parts to fly off resulting in injury to the user.

17. Recompress the spring to remove the spring holder.
18. Lubricate the O-ring on the top cap with a smear of fork oil then screw the top cap fully into the inner tube.
19. Tighten the top cap to **30 Nm**.

Note:

- It is much easier to tighten the top cap when the fork is securely clamped in the bottom yoke.
20. Install the fork(s) as described on page 14.5.

Steering Head Bearing Check and Adjustment



Before starting work, ensure the motorcycle is stabilised and adequately supported. This will help prevent it from falling and causing injury to the operator or damage to the motorcycle.

Check

1. Raise and support the motorcycle so that the front wheel is clear of the ground.
2. Move the handlebars from lock-to-lock whilst checking for signs of tight spots or notchiness (bearings over-tightened).
3. Hold the lower end of the front forks and try to move them forward and backward to check for signs of free play in the bearings (bearings insufficiently tightened or worn).

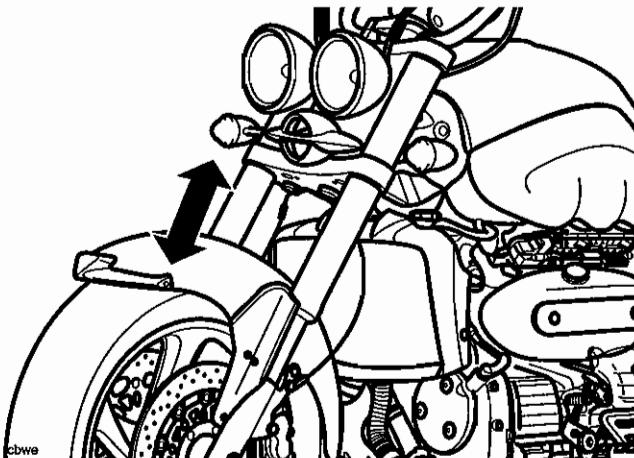

Checking for free play in steering head bearings

4. Adjust as described below then lower the motorcycle to the ground.

Adjustment

1. Slacken the top yoke clamp bolts.

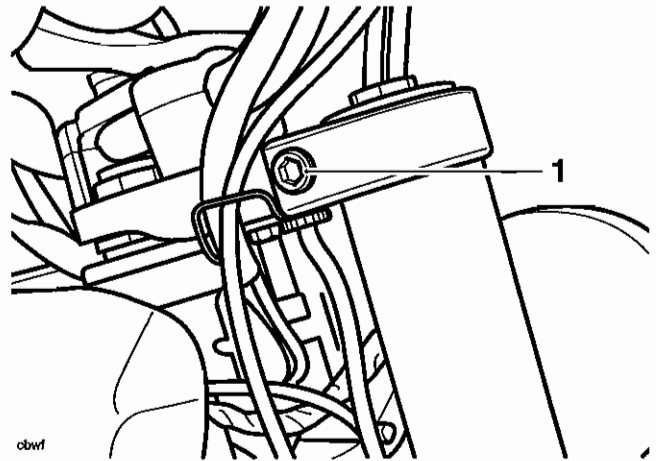

1. Top yoke clamp bolt

2. Release the two screws securing the upper cover of the handlebar clamp to the lower section.

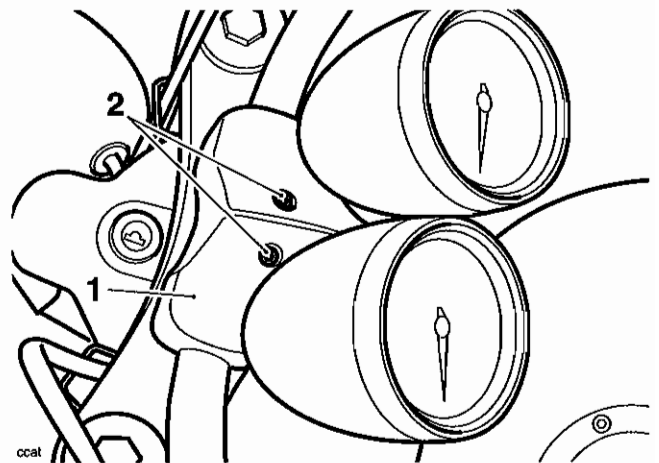

1. Upper cover

2. Screws

Front Suspension

3. Pivot the instruments forward to reveal the steering stem top nut.

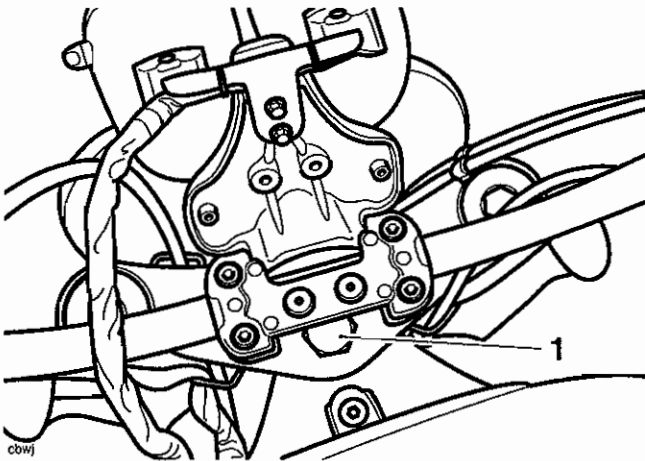

1. Top nut

Note:

- When the handlebars and top yoke are removed (below), the steering lock and headlights will also be removed as part of the assembly.
4. Slacken and remove the top nut and washer. Lift and support the handlebar and top yoke assembly to gain access to the bearing adjuster nut and locknut.

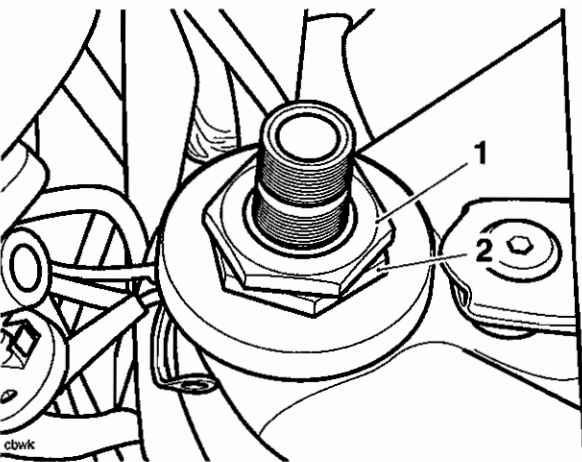

1. Locknut

2. Adjuster nut

5. Slacken the locknut and adjuster nut.
6. Adjust the bearing free play as follows:
 - a) Tighten the adjuster nut to **40 Nm**.
 - b) Slacken the adjuster nut fully.
 - c) Re-tighten the adjuster nut to **6 Nm**.
 - d) Loosen the adjuster nut by 90°. Note that there will now be free-play present.
 - e) Hold the adjuster nut in that position while tightening the locknut to **40 Nm**.

Note:

- Ensure the adjuster nut does not move as the locknut is tightened.
7. Seat the top yoke assembly in position then refit the washer and top nut, tightening it to **65 Nm**.

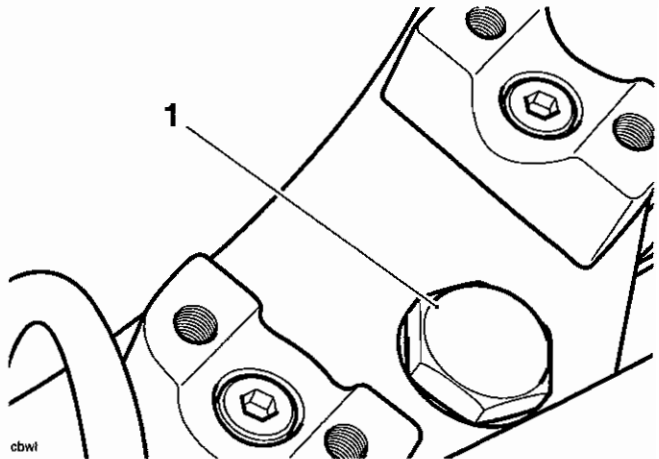

1. Top nut

8. Check that the free play has been eliminated and that the steering can be turned freely from lock to lock without any sign of tightness. Re-adjust if necessary.

Warning

Operation of the motorcycle with incorrectly adjusted steering head bearings, either too loose or too tight, may cause a dangerous riding condition leading to loss of motorcycle control and an accident.

9. Tighten the top yoke clamp bolts to **20 Nm**.
10. Pivot the instruments back to their normal position, fit the two bolts to the upper cover and tighten them to **3 Nm**.

Bottom Yoke and Headstock Bearings

Yoke Removal

Warning
Before starting work, ensure the motorcycle is stabilised and adequately supported. This will help prevent it from falling and causing injury to the operator or damage to the motorcycle.

1. Remove both forks as described on page 14.4.
2. Release the two screws securing the upper cover of the handlebar clamp to the lower half.

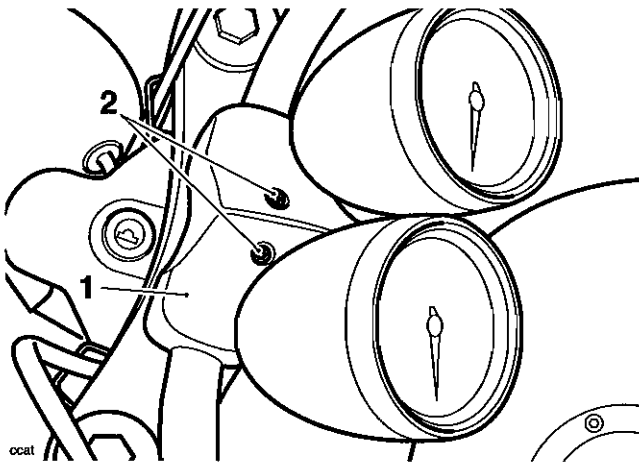

1. Upper cover
2. Screws
3. Slacken the top yoke clamp bolts.
4. Pivot the instruments forward to reveal the top nut.

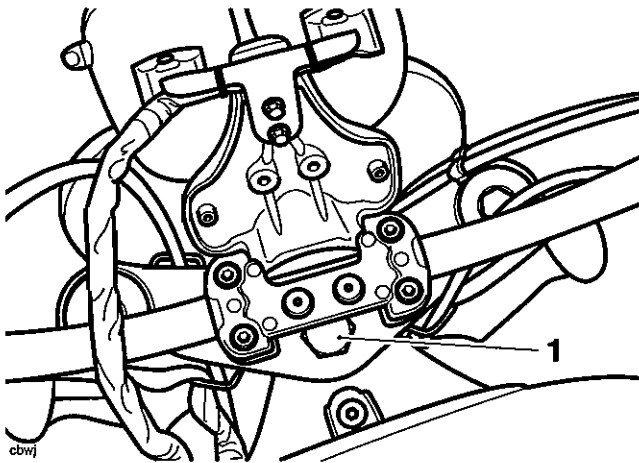

1. Top nut

5. Slacken and remove the top nut and washer from the steering stem. Lift and support the handlebar and top yoke assembly to gain access to the bearing adjuster nut and locknut.

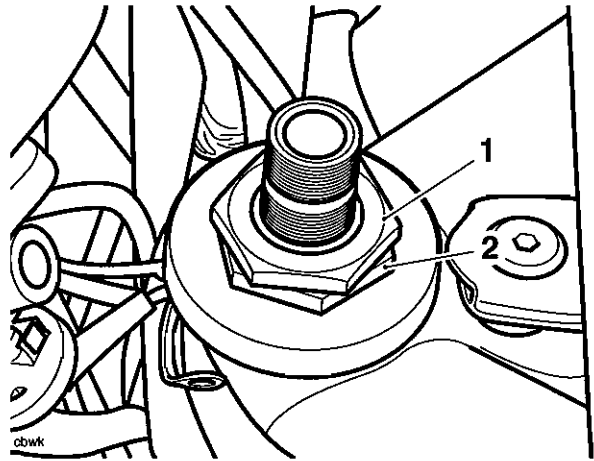

1. Locknut
2. Adjuster nut
6. Remove the locknut and adjuster nut.
7. Detach the bottom yoke from below the frame headstock.

Bearing removal

1. Using a suitable drift, evenly and progressively drive the bearing outer races from the frame headstock.
2. Remove the inner race and dust seal from the bottom yoke using a press or puller.

Caution

Protect the threads of the bottom yoke when using a press or puller as damaged threads may mean replacing the yoke completely.

Front Suspension

Installation

1. Fit a new dust shield to the steering stem on the bottom yoke.

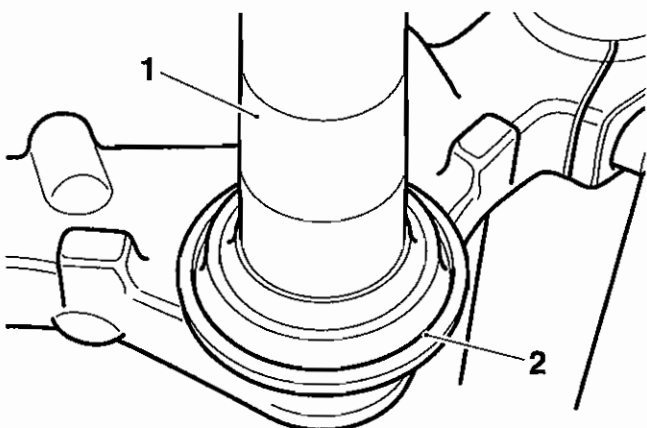

ccau

1. Steering stem
2. Dust shield

2. Press a new inner race onto the steering stem of the bottom yoke.

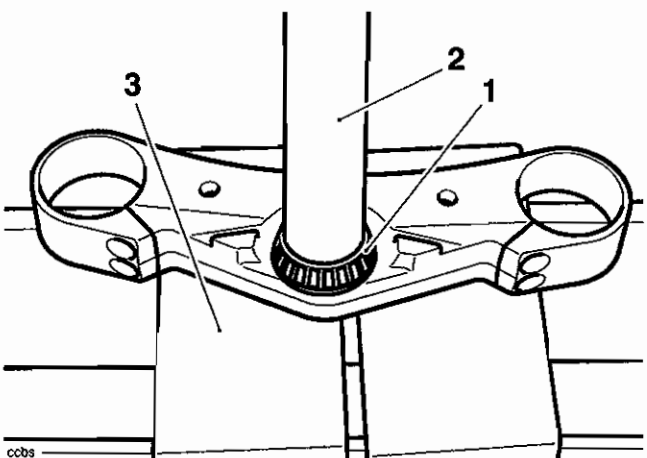

ccbs

1. Bearing
2. Press
3. Press bed

3. Evenly and progressively drive new bearing outer races into the frame headstock.

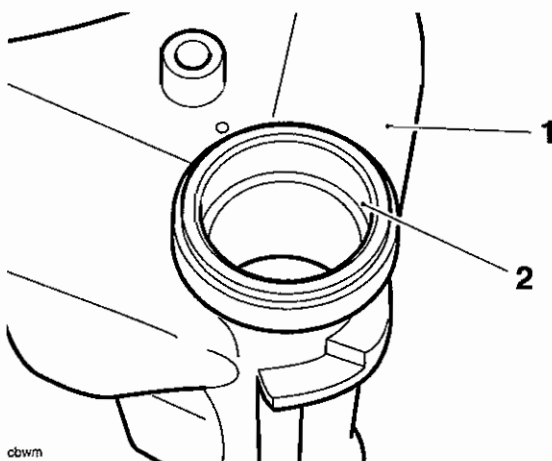

cbwm

1. Headstock
2. Bearing outer race
3. Bottom yoke installation

4. Lubricate the headstock bearings using multi-purpose grease.

5. Insert the lower yoke to the frame headstock, fit the upper bearing and retain with the adjuster nut.

6. Adjust the bearing free play as follows:
 - a) Tighten the adjuster nut to **40 Nm**.
 - b) Slacken the adjuster nut fully.
 - c) Re-tighten the adjuster nut to **6 Nm**.
 - d) Loosen the adjuster nut by 90°. Note that there will now be free-play present.
 - e) Hold the adjuster nut in that position while tightening the locknut to **40 Nm**.

7. Seat the top yoke assembly in position then refit the washer and top nut, tightening it to **65 Nm**.

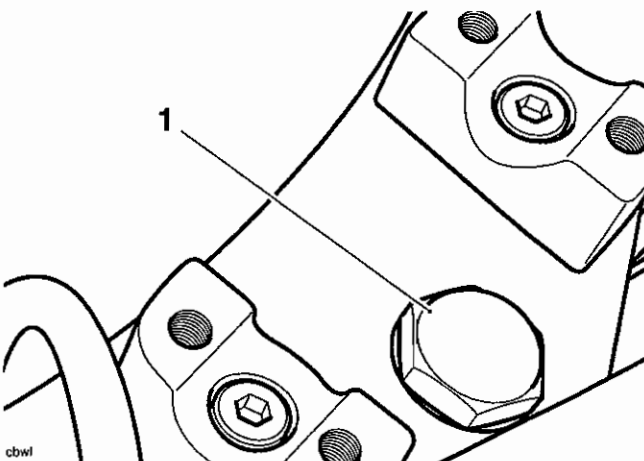

cbwl

1. Top nut

8. Check that the free play has been eliminated and that the steering can be turned freely from lock to lock without any sign of tightness. Re-adjust if necessary.

 **Warning**

Operation of the motorcycle with incorrectly adjusted steering head bearings, either too loose or too tight, may cause a dangerous riding condition leading to loss of motorcycle control and an accident.

9. Install the forks as described on page 14.5.
10. Recheck that the free play has been eliminated and that the steering can be turned freely from lock to lock without any sign of tightness. Re-adjust if necessary.

 **Warning**

Operation of the motorcycle with incorrectly adjusted steering head bearings, either too loose or too tight, may cause a dangerous riding condition leading to loss of motorcycle control and an accident.

11. Pivot the instruments back to their normal position, fit the two bolts to the upper cover and tighten them to **3 Nm**.

This page intentionally left blank

15 Brakes

Table of Contents

| | |
|---|-------|
| Exploded View - Front Brake Master Cylinder | 15-3 |
| Exploded View - Front Brake Caliper and Disc | 15-4 |
| Exploded View - Rear Brake Master Cylinders | 15-5 |
| Exploded View - Rear Brake Caliper and Disc | 15-6 |
| Braking System Maintenance Safety Precautions | 15-7 |
| Brake Fluid Level Inspection | 15-8 |
| Changing Brake Fluid | 15-8 |
| Brake Pads | 15-8 |
| Brake Wear Inspection | 15-8 |
| Bleeding the Front Brakes, Renewing Brake Fluid | 15-9 |
| Front Brake Pads | 15-11 |
| Removal | 15-11 |
| Installation | 15-11 |
| Front Brake Caliper | 15-13 |
| Removal | 15-13 |
| Disassembly | 15-13 |
| Inspection | 15-14 |
| Assembly | 15-14 |
| Installation | 15-14 |
| Front Discs | 15-15 |
| Wear | 15-15 |
| Removal | 15-15 |
| Installation | 15-16 |
| Front Brake Master Cylinder | 15-16 |
| Removal | 15-16 |
| Disassembly | 15-17 |
| Inspection | 15-17 |
| Assembly | 15-18 |
| Installation | 15-18 |
| Bleeding the Rear Brakes, Renewing Brake Fluid | 15-20 |
| Rear Brake Pads, Rear Brake Caliper | 15-22 |
| Removal | 15-22 |

Brakes

| | |
|----------------------------|-------|
| Installation | 15-23 |
| Rear Brake Caliper | 15-24 |
| Rear Brake Disc | 15-24 |
| Wear | 15-24 |
| Removal | 15-25 |
| Installation | 15-25 |
| Rear Master Cylinder | 15-25 |
| Removal | 15-25 |
| Disassembly | 15-26 |
| Inspection | 15-27 |
| Assembly | 15-27 |
| Installation | 15-28 |

Exploded View - Front Brake Master Cylinder

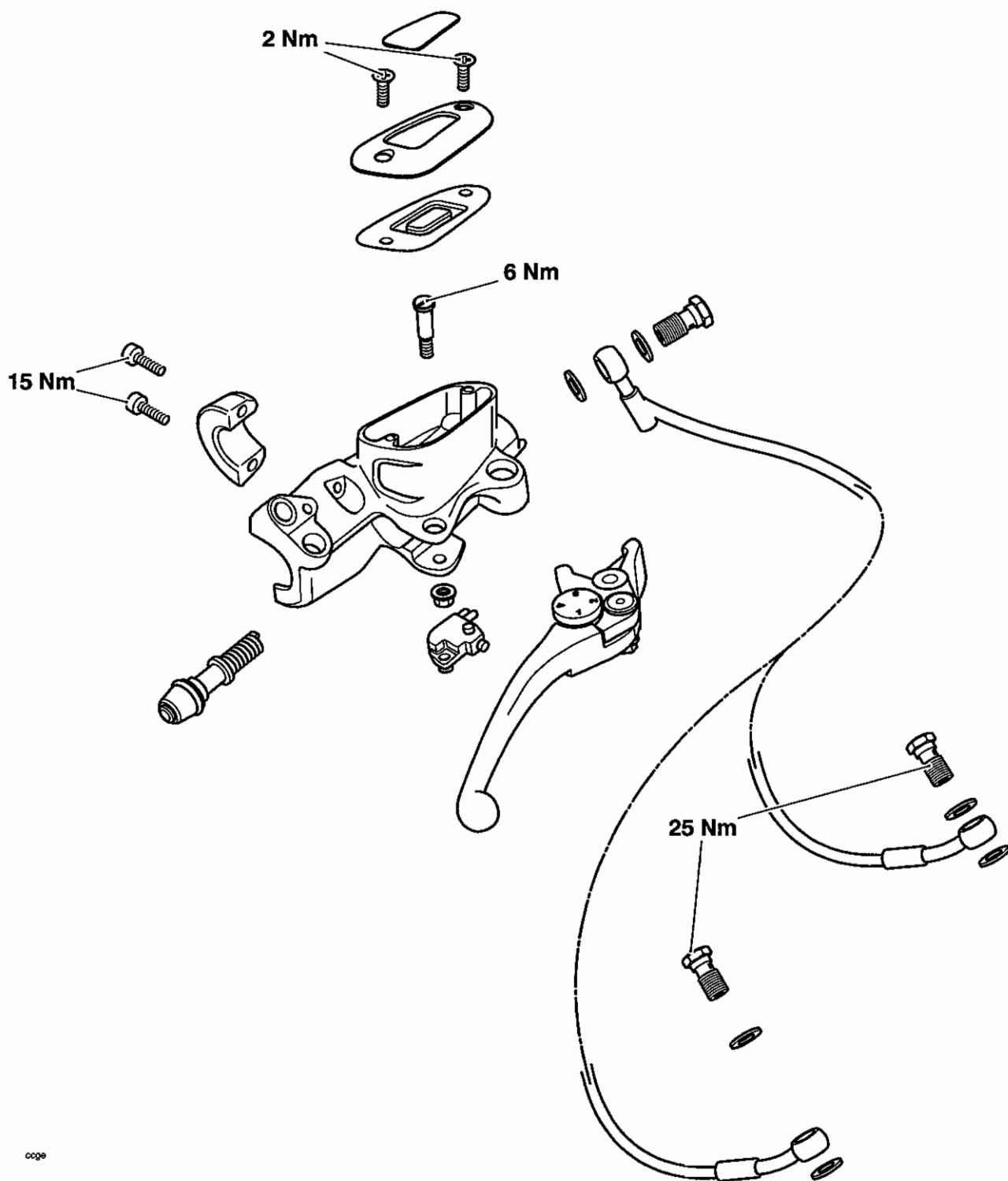

0000

Brakes

Exploded View - Front Brake Caliper and Disc

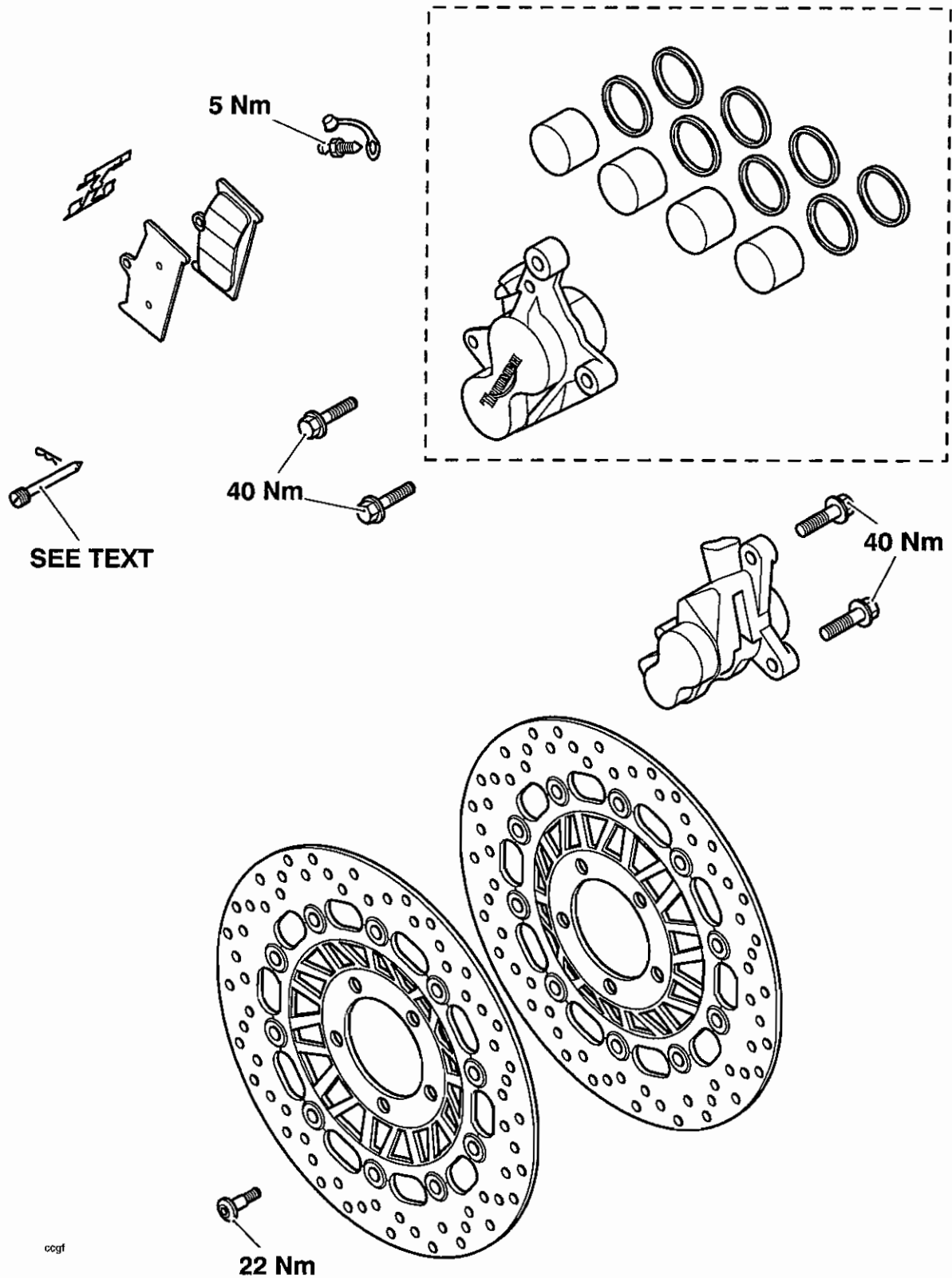

Exploded View - Rear Brake Master Cylinders

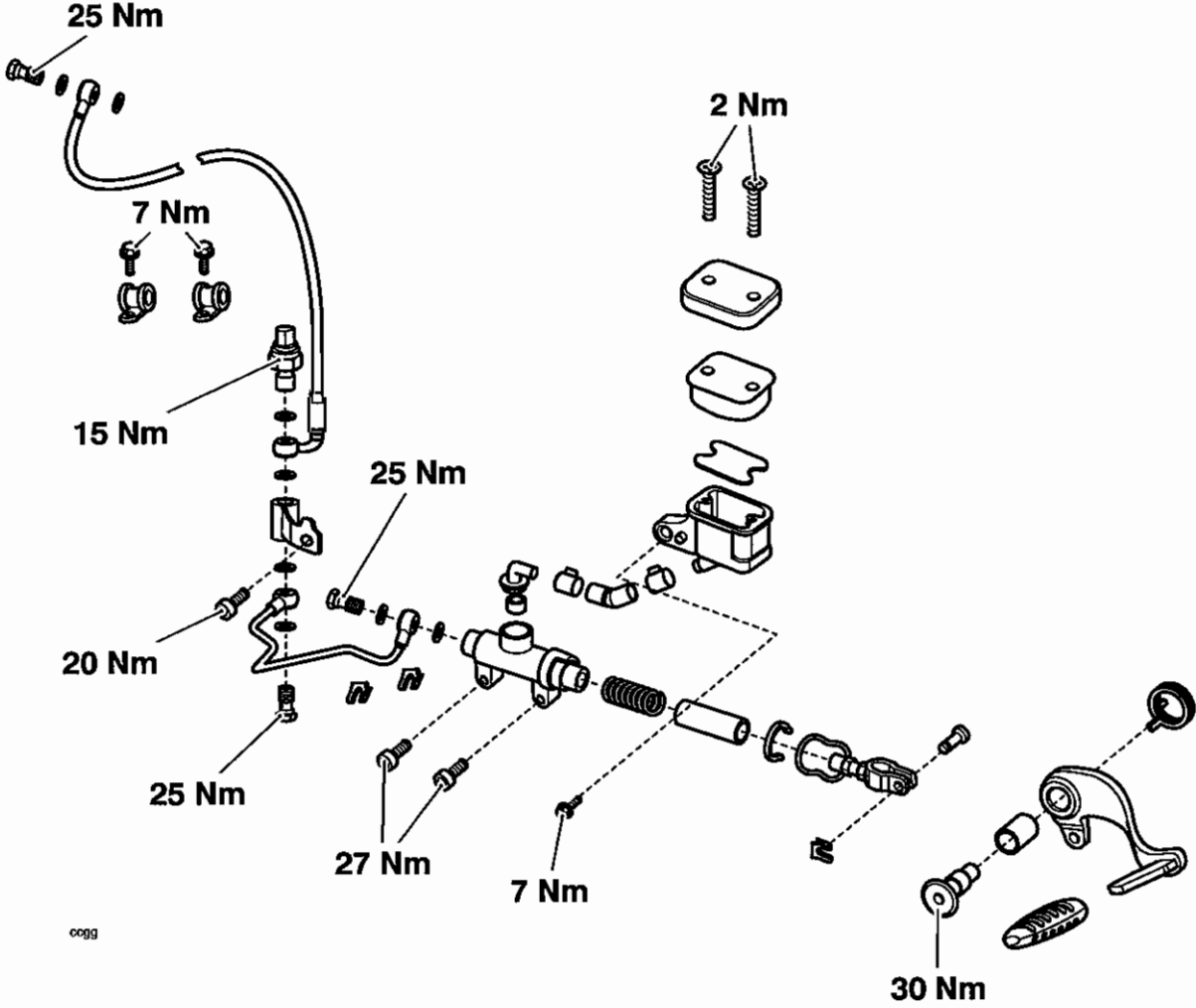

Exploded View - Rear Brake Caliper and Disc

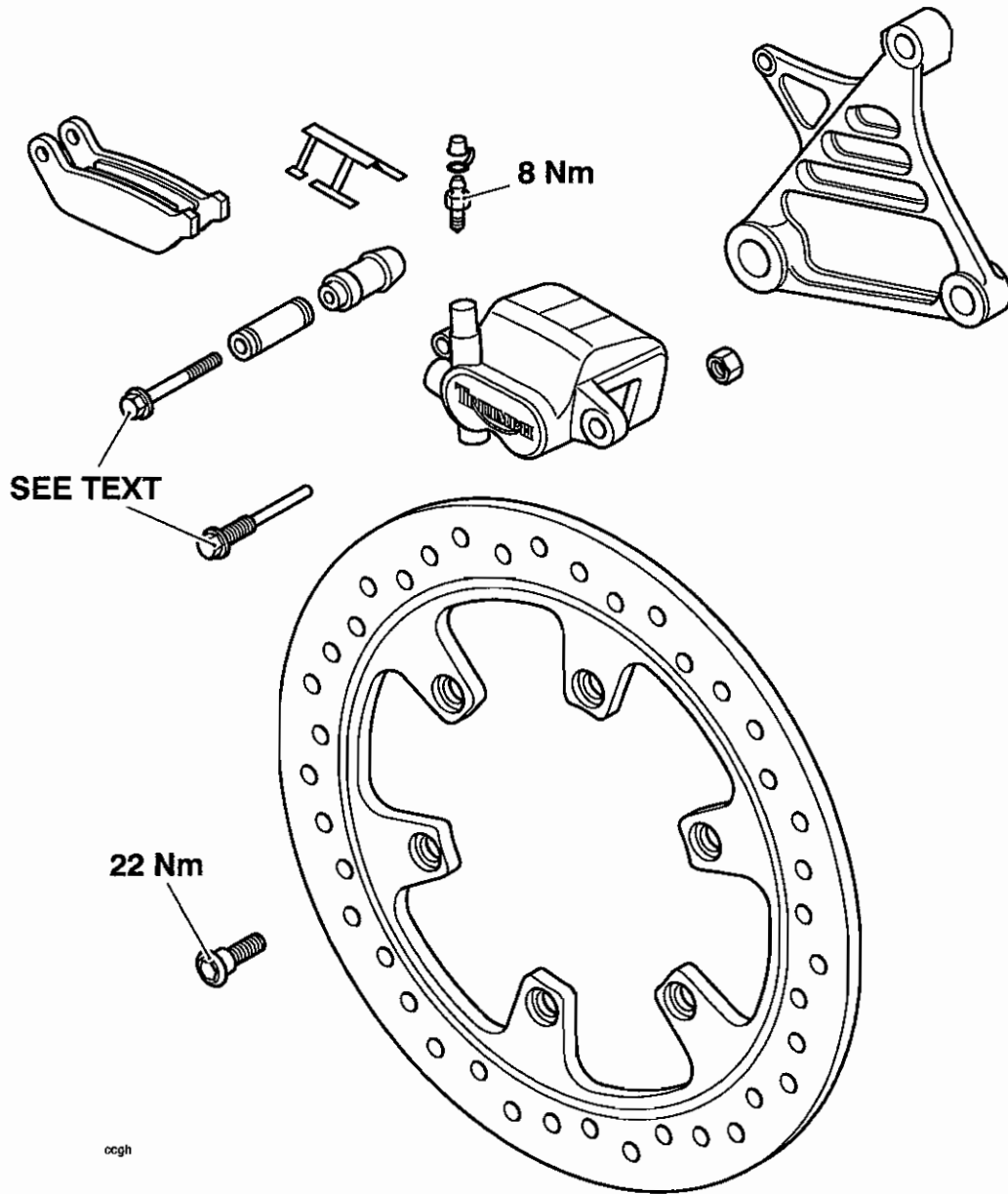

Braking System Maintenance Safety Precautions



Brake fluid is hygroscopic which means it will absorb moisture from the air. The absorbed moisture will greatly reduce the boiling point of the brake fluid causing a reduction in braking efficiency.

Replace brake fluid in line with the scheduled maintenance chart. A dangerous riding condition could result if this important maintenance item is neglected.

Do not spill brake fluid onto any area of the bodywork as this will damage any painted or plastic surface.

Always use new brake fluid from a sealed container and never use fluid from an unsealed container or from one that has been previously opened.

Do not mix different brands of fluid. Check for fluid leakage around brake fittings, seals and joints.

Check regularly for brake hose damage.

FAILURE TO OBSERVE ANY OF THE ABOVE WARNINGS MAY REDUCE BRAKING EFFICIENCY LEADING TO LOSS OF MOTORCYCLE CONTROL AND AN ACCIDENT.



Use only D.O.T. 4 specification brake fluid as listed in the general information section of this manual. The use of brake fluids other than those D.O.T. 4 fluids listed in the general information section may reduce the efficiency of the braking system leading to loss of motorcycle control and an accident.

Failure to change the brake fluid at the interval specified in the scheduled maintenance chart may reduce braking efficiency resulting in loss of motorcycle control and an accident.



Never use mineral based grease in any part of the braking system or in any area where contact with the braking system is possible. Mineral based grease will damage the hydraulic seals in the calipers and master cylinders. Damage caused by contact with mineral based grease may reduce braking efficiency resulting in loss of motorcycle control and an accident.



If there has been an appreciable drop in the level of the fluid in either brake fluid reservoir, consult your authorised Triumph Dealer before riding.

If the brake lever or pedal feels soft when it is applied, or if the lever/pedal travel becomes excessive, there may be air in the brake lines or the brake may be defective.

It is dangerous to operate the motorcycle under such conditions and you must have your authorised Triumph dealer take remedial action before you attempt to ride the motorcycle again. Failure to take remedial action may reduce braking efficiency leading to loss of motorcycle control and an accident.

Brakes

Brake Fluid Level Inspection



Before starting work, ensure the motorcycle is stabilised and adequately supported. This will help prevent it from falling and causing injury to the operator or damage to the motorcycle.

In accordance with the scheduled maintenance chart, inspect the brake fluid level in the front and rear master cylinder reservoirs.

1. Ensure that the brake fluid level in the front and rear brake fluid reservoirs is between the upper and lower level lines (reservoir held horizontal).

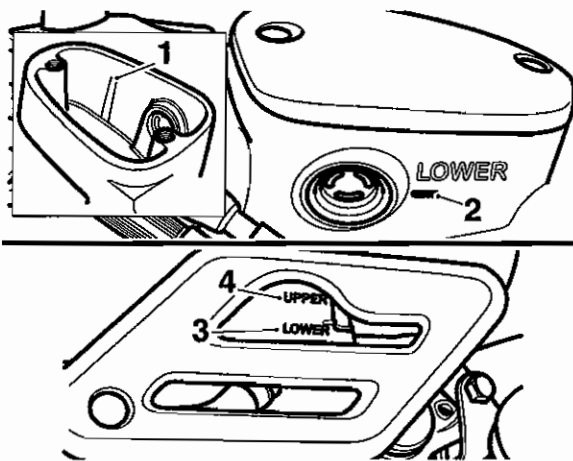

1. Front reservoir upper level
2. Front reservoir lower level
3. Rear reservoir lower level
4. Rear reservoir upper level

Changing Brake Fluid

Brake fluid must be changed every two calendar years, irrespective of the mileage the motorcycle has covered in that time.

Brake Pads

Front and rear brake pad wear is automatically compensated for and has no effect on brake lever or pedal action.

Brake Wear Inspection

In accordance with the scheduled maintenance chart, inspect the brake pads for wear. The minimum thickness of lining material for any front or rear brake pad is 1.5mm. If any pad has worn to the bottom of the groove in the pad centre, replace all the brake pads on that wheel.

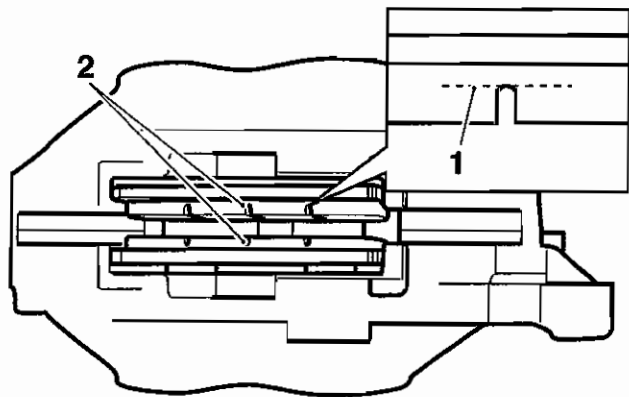

obyw

1. Lining material thickness
2. Centre groove



Do not replace individual brake pads, replace both pads in the brake caliper. On the front where two calipers are mounted on the same wheel, all the pads in both calipers must be replaced simultaneously. Replacing individual pads will reduce braking efficiency and may cause loss of motorcycle control and an accident.

Bleeding the Front Brakes, Renewing Brake Fluid

Warning

Before starting work, ensure the motorcycle is stabilised and adequately supported. This will help prevent it from falling and causing injury to the operator or damage to the motorcycle.

1. Note the original setting of the brake lever adjuster in order that it can be returned to the same position when the bleeding operation is complete. Set the brake lever adjuster to position No.1.

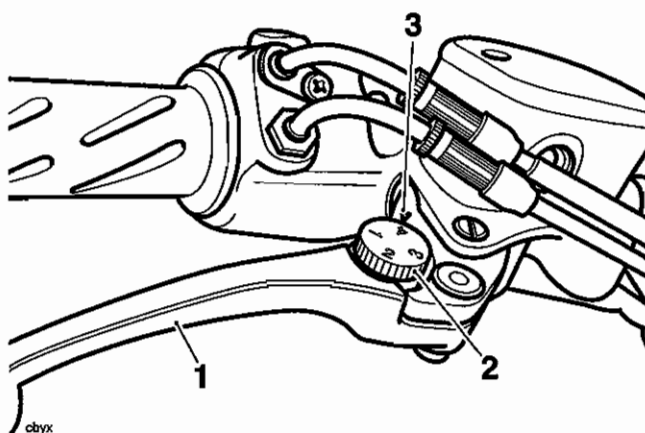

1. Lever
2. Adjuster wheel
3. Triangular mark

2. Remove the cap from the bleed nipple on the right hand caliper.
3. Attach a transparent tube to the bleed nipple.

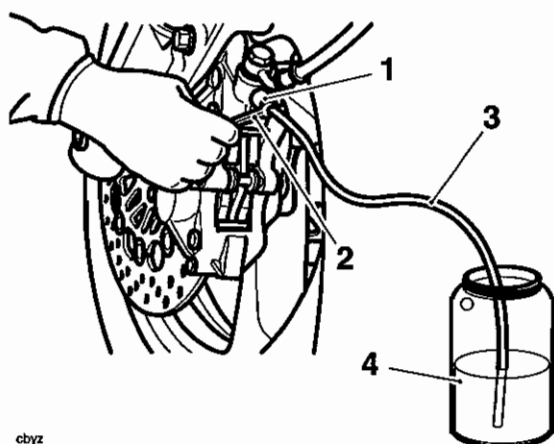

1. Bleed Nipple
2. Spanner
3. Bleed Tube
4. Container

4. Place the other end of the tube in a suitable receptacle containing new brake fluid.
5. Turn the handlebars to bring the fluid reservoir to a level position.
6. Remove the screws from the reservoir cover.

Warning

Ensure absolute cleanliness when adding brake fluid to the brake fluid reservoir. Do not allow moisture or debris to enter the cylinder, as this will adversely affect the fluid properties. Always use fluid from a sealed container and do not use fluid from a container that has been opened for any period of time. Always check for fluid leakage around hydraulic fittings and for damage to hoses. A dangerous riding condition leading to loss of motorcycle control and an accident could result if this warning is ignored.

Caution

To prevent paint damage, do not spill brake fluid onto any area of the bodywork. Spilled brake fluid will damage paintwork.

7. Carefully remove the reservoir cover taking care not to spill any fluid.
8. Check the condition of the sealing diaphragm for the reservoir. Replace if necessary.

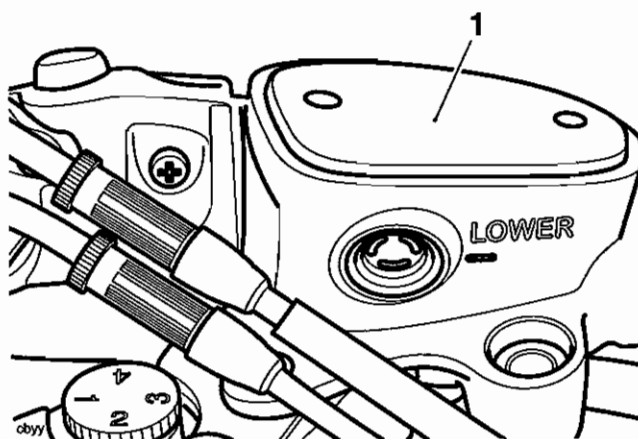

1. Diaphragm
9. Release the bleed nipple.

Brakes

Warning

Use only D.O.T. 4 specification brake fluid as listed in the general information section of this manual. The use of brake fluids other than those D.O.T. 4 fluids listed in the general information section may reduce the efficiency of the braking system leading to an accident. Observe the brake fluid handling warnings given earlier in this section of the manual.

Note:

- **During bleeding, do not allow the fluid level to fall below the lower level mark in the reservoir. If the fluid level is allowed to fall below this mark, air may enter the system and the sequence of bleeding must be repeated.**
10. Slowly pull the brake lever to the handlebar and, holding the lever fully in, close the bleed nipple. Repeat steps 9 and 10 until no more air appears in the bleed tube, maintaining the brake fluid level between the upper and lower reservoir levels whilst bleeding is being carried out.
 11. When all air has been expelled from the system, hold the lever in and close the bleed nipple. Tighten the nipple to **7 Nm**.
 12. Fill the reservoir to the upper level with new DOT 4 fluid.

Warning

Use only D.O.T. 4 specification brake fluid as listed in the general information section of this manual. The use of brake fluids other than those D.O.T. 4 fluids listed in the general information section may reduce the efficiency of the braking system leading to loss of motorcycle control and an accident.

Observe the brake fluid handling warnings given earlier in this section of the manual.

Caution

To prevent paint damage, do not spill brake fluid onto any area of the bodywork. Spilled brake fluid will damage paintwork.

13. Remove the bleed tube.
14. Replace the bleed nipple cap.
15. Repeat the procedure for the left-hand caliper.

16. When both calipers have been bled, ensure the brake lever operation has a firm resistive feel to it, does not feel spongy and that the lever cannot be pulled directly back to the handlebar. Take remedial action as necessary.
17. Refit the diaphragm and reservoir cover. Tighten the screws to **2 Nm**.

Warning

Always return the lever adjuster to the original setting as noted in paragraph 1. Operating the motorcycle with lever settings that are unfamiliar may lead to loss of control or an accident.

18. Reset the brake lever adjuster to the original setting.
19. Check the operation of the front brake. Rectify as necessary.

Warning

It is dangerous to operate the motorcycle with defective brakes and you must have your authorised Triumph Dealer take remedial action before you attempt to ride the motorcycle again. Failure to take remedial action may reduce braking efficiency leading to loss of motorcycle control and an accident.

Front Brake Pads

Removal

Warning

Before starting work, ensure the motorcycle is stabilised and adequately supported. This will help prevent it from falling and causing injury to the operator or damage to the motorcycle.

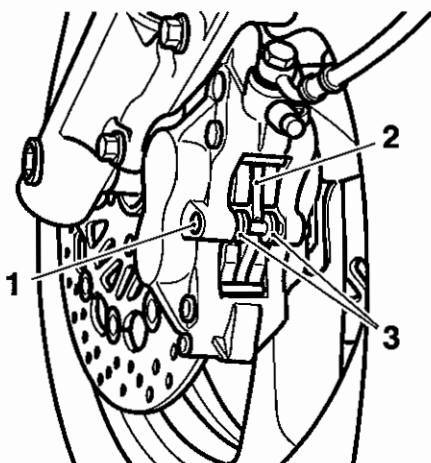

cbza

1. Retaining Pin
2. Anti-rattle Spring
3. Brake Pads

1. Remove the brake pad retaining pin after removing and discarding its split pin. Inspect the retaining pin for damage.
2. Remove the anti-rattle spring and inspect the spring for damage.

Caution

In the following operation, never lever directly against the disc, caliper or the pad lining material as this will damage these components. Always use a levering tool made from a soft material that will not cause damage to the load bearing surfaces.

Brake fluid will be displaced as the caliper pistons are compressed. To prevent paint damage, ensure that the displaced fluid does not come into contact with any part of the bodywork.

3. Carefully push the brake pads apart to force the caliper pistons back and allow withdrawal of the pads.

4. Remove both brake pads and inspect for damage and wear beyond the service limit.

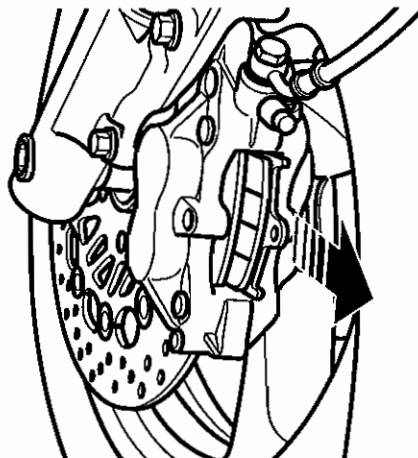

cbzb

Brake pad removal

Note:

- Complete the assembly of the brake pads to one caliper (see assembly for details) before removing the pads from the other caliper.

Installation

Warning

Never use mineral based grease in any part of the braking system or in any area where contact with the braking system is possible. Mineral based grease will damage the hydraulic seals in the calipers and master cylinders.

Damage caused by contact with mineral based grease may reduce braking efficiency resulting in loss of motorcycle control and an accident.

Brakes

1. Fit new brake pads as an axle set or, if all the pads are in a serviceable condition, clean the pad grooves before refitting all pads in their original positions.

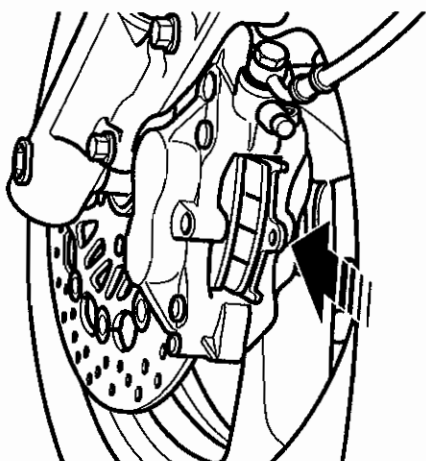

cbzc

Installing brake pads

! Warning

Do not apply more than a minimum coating of grease to the pad retaining pins. Excess grease may contaminate the brake pads, hydraulic seals and discs causing reduced braking efficiency leading to loss of motorcycle control and an and an accident.

2. Lubricate the pad retaining pins using a minimum amount of proprietary high temperature 'Copperslip' type grease.
3. Fit the anti-rattle spring over the pads and push down in the centre to allow the pad retaining pin to slide across the top of the spring.
4. Tighten the pad retaining pin to **18 Nm**, and secure with a new split pin.
5. Pump the brake lever to correctly position the caliper pistons.

! Warning

Use only D.O.T. 4 specification brake fluid as listed in the general information section of this manual. The use of brake fluids other than those D.O.T. 4 fluids listed in the general information section may reduce the efficiency of the braking system leading to an accident. Observe the brake fluid handling warnings given on page 1.4.

! Caution

To prevent paint damage, do not spill brake fluid onto any area of the bodywork. Spilled brake fluid will damage paintwork.

6. Check the front brake fluid level and top up as required with new DOT 4 fluid.
7. Check the operation of the front brake. Rectify as necessary.

! Warning

It is dangerous to operate the motorcycle with defective brakes and you must have your authorised Triumph Dealer take remedial action before you attempt to ride the motorcycle again. Failure to take remedial action may reduce braking efficiency leading to loss of motorcycle control and an accident.

Front Brake Caliper

Removal

! Warning
Before starting work, ensure the motorcycle is stabilised and adequately supported. This will help prevent it from falling and causing injury to the operator or damage to the motorcycle.

! Caution
To prevent paint damage, do not spill brake fluid onto any area of the bodywork. Spilled brake fluid will damage paintwork.

1. Disconnect the brake hose at the caliper and place the free end of the hose in a suitable container to collect any displaced brake fluid.
2. Remove the brake pads as described on page 15.11.
3. Remove the two caliper bolts.
4. Manoeuvre the caliper clear of the disc, taking care not to damage the wheel.

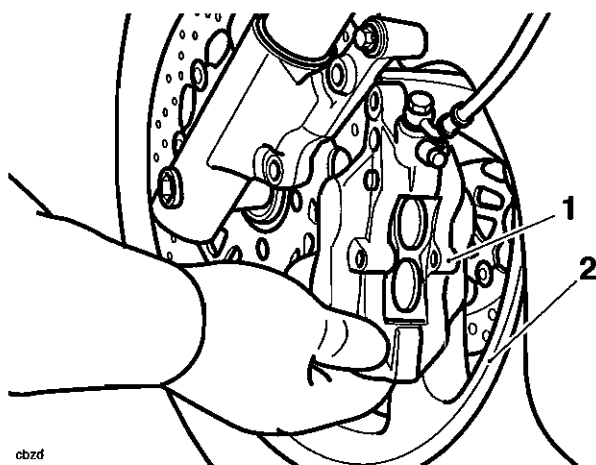

- cbzd
1. Caliper
 2. Wheel

Disassembly

! Warning
Do not attempt to split the two halves of the caliper. A dangerous riding condition leading to loss of motorcycle control and an accident could occur if this warning is ignored.

! Warning
To prevent injury, never place fingers or hands inside the caliper opening when removing the pistons. Always wear eye, hand and face protection when using compressed air. Eye, face and skin damage will result from direct contact with compressed air or brake fluid.

1. Cover the caliper opening with a clean, heavy cloth and, using either compressed air blown into the brake hose connection point, or by reconnecting the master cylinder and pumping the brake lever, remove each of the pistons, one at a time.

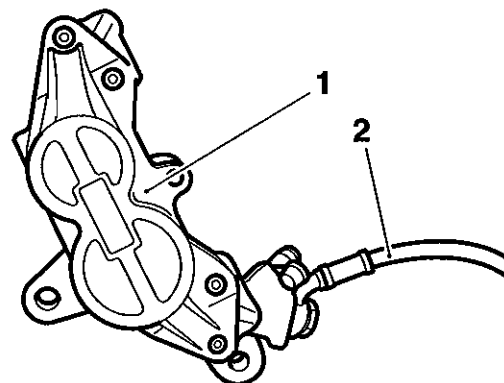

cbze

1. Caliper
2. Fluid supply

Brakes

Inspection

1. Check the pistons and caliper bores for corrosion, scoring and damage. Renew as necessary.

Warning

Always renew caliper seals and pistons after removal from the caliper. An effective hydraulic seal can only be made if new components are used. A dangerous riding condition leading to an accident could result if this warning is ignored.

2. Inspect the brake pads for damage and wear beyond the service limit. Renew as necessary.

Assembly

Warning

Never use mineral based grease in any part of the braking system or in any area where contact with the braking system is possible. Mineral based grease will damage the hydraulic seals in the calipers and master cylinders. A dangerous riding condition leading to loss of motorcycle control and an accident could result from use of mineral grease.

1. Fit new fluid seals to the piston bores in the caliper.

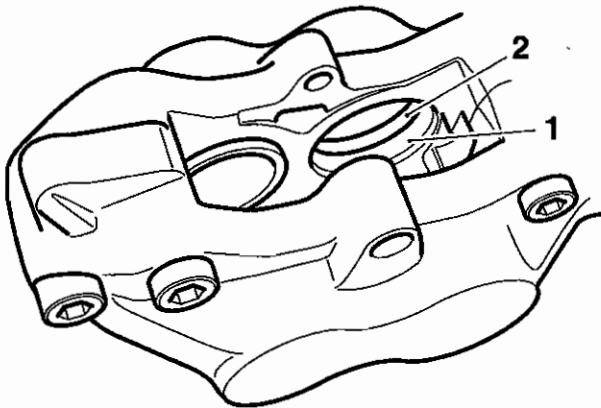

cbzf

1. Caliper bore
2. Fluid seal

Warning

Ensure that the bores do not become scratched during piston removal and assembly. Ensure that the pistons remain square to their bores during fitment, as incorrect fitment can lead to seal and bore damage. A dangerous riding condition leading to loss of control and an accident could result from damaged seals and/or bores.

2. Apply brake fluid to the outside of the caliper pistons and fluid seals.
3. Carefully push the pistons fully and squarely into the caliper bores by hand.

Installation

1. Position the caliper over the disc taking care not to damage the wheel.
2. Tighten the caliper bolts to **40 Nm**.
3. Refit the brake pads as described on page 15.11.
4. Connect the brake hose to the caliper incorporating new sealing washers on each side of the union.
5. Tighten the brake hose union bolt to **25 Nm**.

Warning

Use only D.O.T. 4 specification brake fluid as listed in the general information section of this manual. The use of brake fluids other than those D.O.T. 4 fluids listed in the general information section may reduce the efficiency of the braking system leading to loss of motorcycle control and an accident. Observe the brake fluid handling warnings given earlier in this section of the manual.

Caution

To prevent body damage, do not spill brake fluid onto any area of the bodywork. Spilled brake fluid will damage paintwork.

6. Fill the master cylinder with new, DOT 4 brake fluid from a sealed container.
7. Bleed the front brake line as described on page 15.9.
8. Check the operation of the front brake. Rectify as necessary.

Warning

It is dangerous to operate the motorcycle with defective brakes and you must have your authorised Triumph Dealer take remedial action before you attempt to ride the motorcycle again. Failure to take remedial action may reduce braking efficiency leading to loss of motorcycle control and an accident.

Front Discs

Warning

Before starting work, ensure the motorcycle is stabilised and adequately supported. This will help prevent it from falling and causing injury to the operator or damage to the motorcycle.

Wear

1. Replace any brake disc if worn beyond the service limit or exceeds the disc run-out limit.

| Front Disc Thickness | |
|----------------------|--------|
| Standard | 5.0 mm |
| Service limit | 4.0 mm |

| Disc Run-out | |
|---------------|--------|
| Standard | 0.1 mm |
| Service limit | 0.3 mm |

Measure disc run out using an accurate dial gauge mounted on a surface plate.

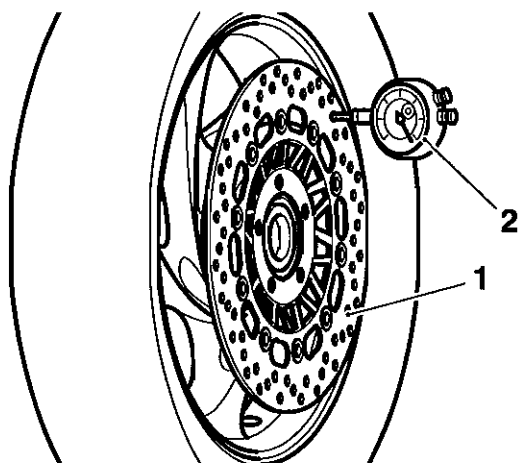

1. Disc
2. Dial Gauge

Removal

Warning

Do not renew front brake discs individually. Discs must always be renewed in pairs even if one of a pair is serviceable. A dangerous riding condition leading to loss of motorcycle control and an accident could result if this warning is ignored.

1. Remove the front wheel as described on page 16.6.

Warning

To avoid wheel damage, always support the wheel as instructed below. A dangerous riding condition leading to loss of motorcycle control and an accident could result if this warning is ignored.

2. Support the wheel on blocks as illustrated.

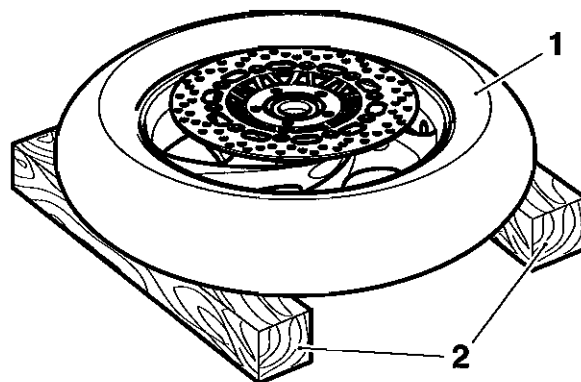

cbzh

1. Wheel
2. Support block
3. Remove and discard the disc securing bolts.
4. Detach the disc.
5. Repeat operations 2, 3 and 4 to remove the disc on the opposite side.

Brakes

Installation

1. Locate the first disc on the correct side of the wheel (offset of disc outwards) as noted during removal.
2. Fit new disc bolts and tighten to **22 Nm**.
3. Fit the remaining disc in the same way.
4. Refit the wheel as described on page 16.7.
5. Check the operation of the front brake. Rectify as necessary.

Warning

It is dangerous to operate the motorcycle with defective brakes and you must have your authorised Triumph Dealer take remedial action before you attempt to ride the motorcycle again. Failure to take remedial action may reduce braking efficiency leading to loss of motorcycle control and an accident.

Front Brake Master Cylinder

Removal

Warning

Before starting work, ensure the motorcycle is stabilised and adequately supported. This will help prevent it from falling and causing injury to the operator or damage to the motorcycle.

1. Remove the seat and disconnect the battery negative (black) lead first.

Caution

To prevent paint damage, do not spill brake fluid onto any area of the bodywork. Spilled brake fluid will damage paintwork.

2. To drain the fluid from the master cylinder, attach a tube to the right hand caliper bleed nipple, slacken the nipple and operate the brake lever until all fluid has been expelled into a suitable container.
3. Remove the right hand switch cube as described on page 11.116.
4. Disconnect the throttle cables as described on page 11.116.
5. Note the setting of the brake lever adjuster to ensure it is returned to the same position when the overhaul operation is complete.

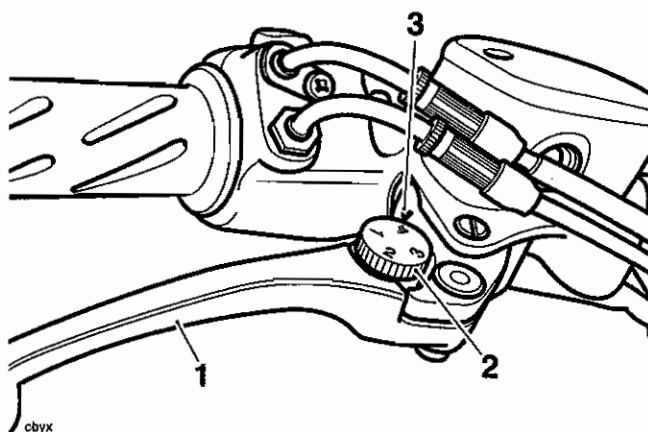

1. Lever
2. Adjuster wheel
3. Triangular mark

6. Disconnect the brake hose and brake light switch connections to the master cylinder.
7. Release the clamp screws from the handlebar to remove the master cylinder.

Disassembly

1. Remove the pivot locknut and bolt securing the brake lever to the master cylinder. Remove the lever.
2. Detach the dust cover from the lever end of the cylinder.

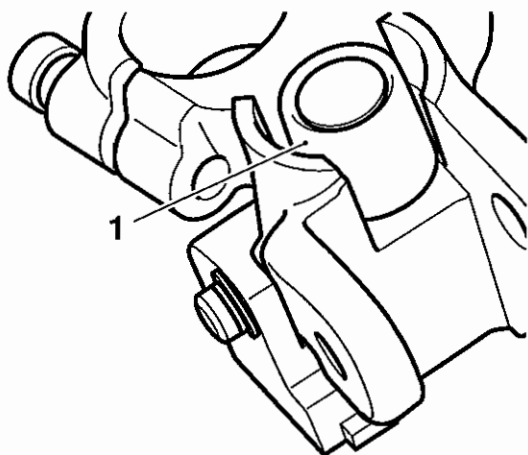

cbzi

1. Dust cover

3. Remove the circlip from beneath the dust cover.

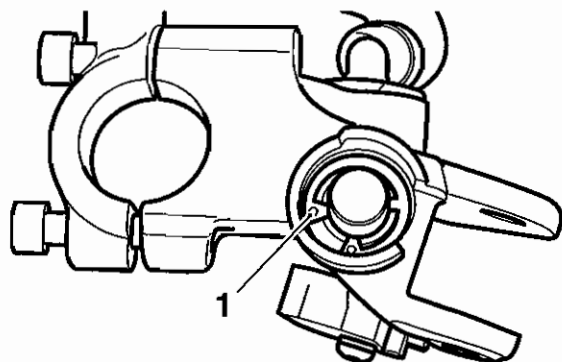

cbzj

1. Circlip

4. Remove the piston set from the master cylinder bore noting the relative position of the seals and piston components.

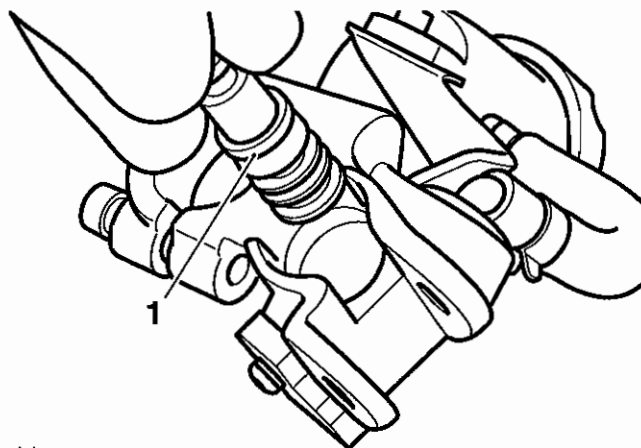

cbzk

1. Piston Set

Inspection

1. Check the following for wear, damage, cracks or deterioration:

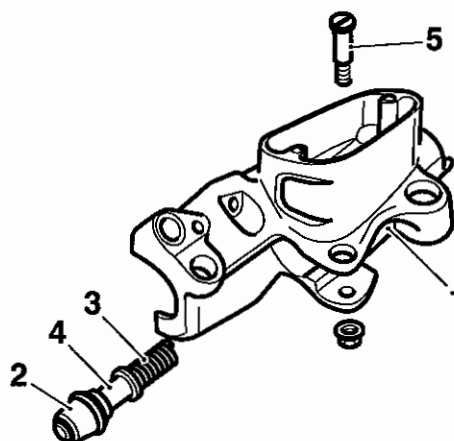

cbzl

1. Cylinder bore (1)
2. Dust cover (2)
3. Spring (3)
4. Piston (4)
5. Pivot Bolt (5)

Note:

- Always renew the piston and seal set if the cylinder is dismantled.

Brakes

2. Check that the relief and supply ports on the cylinder are not blocked.

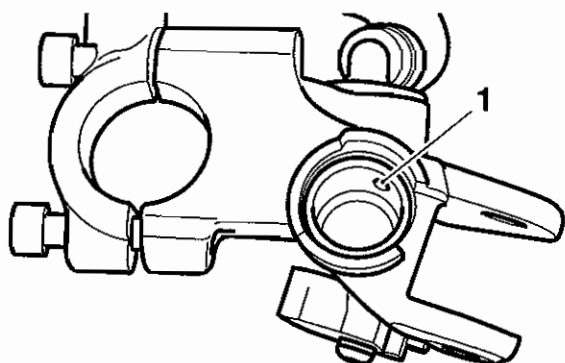

cbzm

1. Ports

Assembly

Warning

Never use mineral based grease in any part of the braking system or in any area where contact with the braking system is possible. Mineral based grease will damage the hydraulic seals in the calipers and master cylinders. A dangerous riding condition leading to loss of motorcycle control and an accident could result if this warning is ignored.

1. Lubricate the piston and cylinder with new, clean brake fluid.

Warning

Ensure that the piston and piston seal are fitted facing the same way as noted during removal. A dangerous riding condition leading to loss of motorcycle control and an accident could result from incorrect assembly of the master cylinder.

2. Fit the new piston set into the master cylinder and retain with a new circlip.

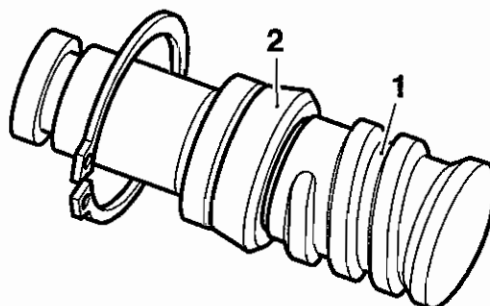

cbzn

1. Piston

2. Seal (in correct orientation)

3. Refit the master cylinder dust cover.

Installation

1. Locate the master cylinder to the handlebars.
2. Position the clamp to the rear side of the handlebars.
3. Align the master cylinder/clamp split line with the dot mark on the underside of the handlebar.

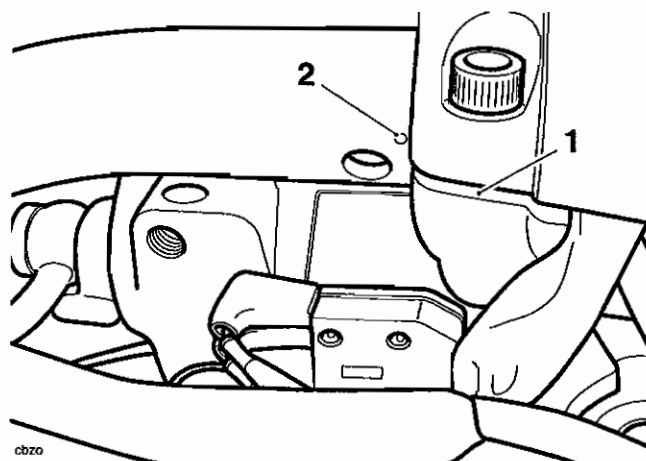

cbzo

1. Split line

2. Dot mark

4. Tighten the clamp bolts, upper first and then the lower to 15 Nm.

5. Connect the brake light switch.

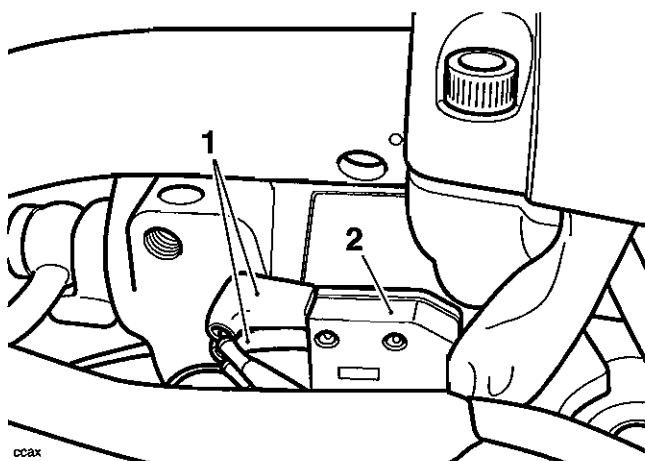

1. Brake light switch connections

6. Position the brake lever ensuring that pivot boss is correctly aligned to the push rod.
7. Fit and tighten the pivot bolt to **6 Nm**, and the locknut to **1 Nm**.
8. Connect the brake hose to the master cylinder incorporating new sealing washers to each side of the union. Tighten the union bolt to **25 Nm**.

Warning

Use only D.O.T. 4 specification brake fluid as listed in the general information section of this manual. The use of brake fluids other than those D.O.T. 4 fluids listed in the general information section may reduce the efficiency of the braking system leading to loss of motorcycle control and an accident. Observe the brake fluid handling warnings given earlier in this section of the manual.

Caution

To prevent body damage, do not spill brake fluid onto any area of the bodywork. Spilled brake fluid will damage paintwork.

9. Reconnect and adjust the throttle cables as described on page 11.117.
10. Refit the right hand switch cube. Tighten the screws to **3 Nm**.
11. Fill and bleed the front brakes as described on page 15.9.

Warning

Always return the lever adjuster to the original setting noted during removal. Operating the motorcycle with lever settings that are unfamiliar may lead to loss of control or an accident.

12. Reset the brake lever adjuster to the original setting.
13. Examine the system for correct operation and fluid leaks. Rectify as necessary.
14. Check the operation of the front brake. Rectify as necessary.

Warning

It is dangerous to operate the motorcycle with defective brakes and you must have your authorised Triumph Dealer take remedial action before you attempt to ride the motorcycle again. Failure to take remedial action may reduce braking efficiency leading to loss of motorcycle control and an accident.

15. Connect the battery positive, (red) lead first, and refit the seat.

Brakes

Bleeding the Rear Brakes, Renewing Brake Fluid

Warning

Before starting work, ensure the motorcycle is stabilised and adequately supported. This will help prevent it from falling and causing injury to the operator or damage to the motorcycle.

1. Remove the cap from the rear bleed nipple.
2. Attach a transparent tube to the bleed nipple.

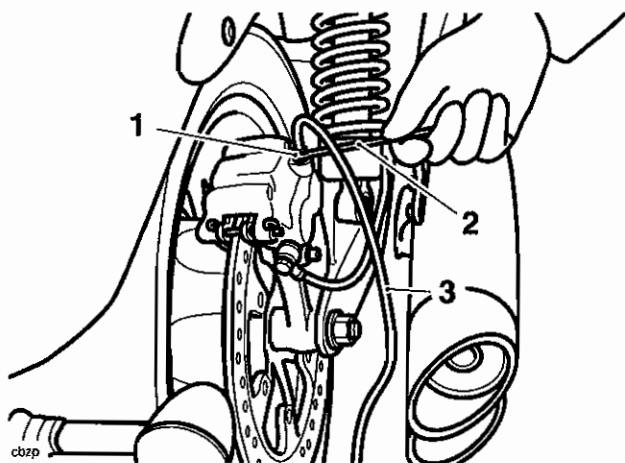

1. Bleed Nipple
2. Spanner
3. Bleed Tube

3. Place the other end of the tube in a suitable receptacle containing new brake fluid.

Caution

To prevent paint damage, do not spill brake fluid onto any area of the bodywork. Spilled brake fluid will damage paintwork.

4. Remove the reservoir protective cover. Unscrew and remove the rear brake reservoir cap taking care not to spill any fluid.

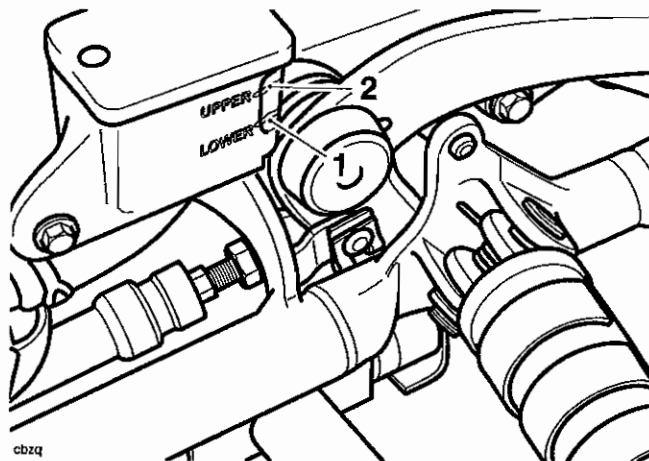

1. Rear Reservoir Lower Level
2. Rear Reservoir Upper Level

Warning

Ensure absolute cleanliness when adding brake fluid to the brake fluid reservoir. Do not allow moisture or debris to enter the cylinder, as this will adversely affect the fluid properties. Always use fluid from a sealed container and do not use fluid from a container that has been opened for any period of time. Always check for fluid leakage around hydraulic fittings and for damage to hoses. A dangerous riding condition leading to loss of motorcycle control and an accident could result if this warning is ignored.

Caution

To prevent paint damage, do not spill brake fluid onto any area of the bodywork. Spilled brake fluid will damage paintwork.

5. Check the condition of the sealing diaphragm. Replace the diaphragm as necessary.

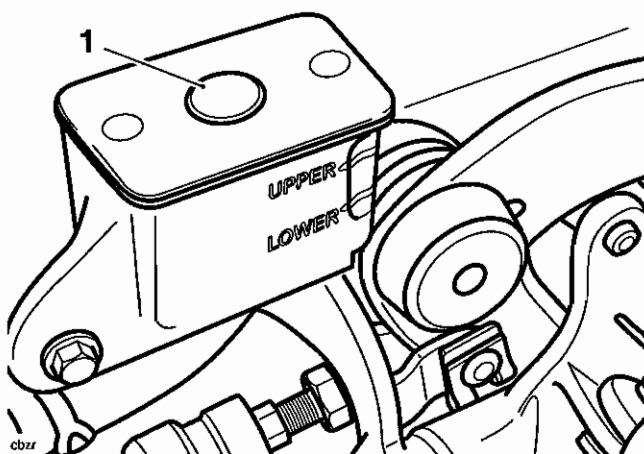

1. Diaphragm

6. Release the bleed nipple.

Note:

- **During bleeding, do not allow the fluid level to fall below the lower level mark in the reservoir. If the level is allowed to fall below this mark, air may enter the system and the sequence of bleeding must be repeated.**
7. Slowly depress the brake pedal and, holding the pedal fully down, close the bleed nipple. Repeat steps 7 and 8 until no more air appears in the bleed tube, maintaining the brake fluid level between the upper and lower reservoir levels whilst bleeding is being carried out.
 8. When all air has been expelled from the system, hold down the brake pedal and close the bleed nipple. Tighten the nipple to **7 Nm**.
 9. Fill the reservoir to the maximum level with new DOT 4 fluid.

! Caution

To prevent paint damage, do not spill brake fluid onto any area of the bodywork. Spilled brake fluid will damage paintwork.

10. Fit the reservoir cover and diaphragm. Check for correct diaphragm fitment before final tightening of the cover.
11. Refit the reservoir cover. Tighten the fixings to 9 Nm.
12. Remove the bleed tube from the nipple.
13. Replace the bleed nipple dust cap.
14. Ensure the brake pedal operation has a firm resistive feel to it, does not feel spongy and that the pedal cannot be depressed through its full range of travel. Rectify as necessary.
15. Check the operation of the rear brake. Rectify as necessary.

! Warning

It is dangerous to operate the motorcycle with defective brakes and you must have your authorised Triumph Dealer take remedial action before you attempt to ride the motorcycle again. Failure to take remedial action may reduce braking efficiency leading to loss of motorcycle control and an accident.

! Warning

Use only D.O.T. 4 specification brake fluid as listed in the general information section of this manual. The use of brake fluids other than those D.O.T. 4 fluids listed in the general information section may reduce the efficiency of the braking system leading to loss of motorcycle control and an accident. Observe the brake fluid handling warnings given earlier in this section of the manual.

Brakes

Rear Brake Pads, Rear Brake Caliper

Removal

1. Raise and support the rear of the motorcycle.

Warning

Before starting work, ensure the motorcycle is stabilised and adequately supported. This will help prevent it from falling and causing injury to the operator or damage to the motorcycle.

2. Release the wheel spindle nut and withdraw the spindle to a point where it clears the caliper carrier.

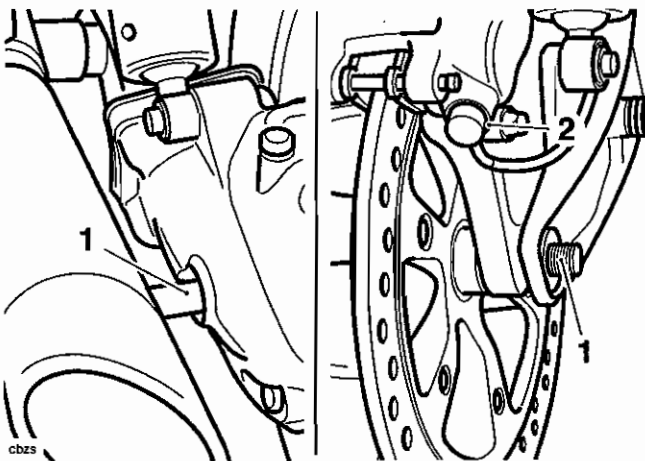

1. Wheel spindle
2. Caliper carrier

3. Release the torque reaction bolt from the caliper carrier, collecting the spacer from between the wheel and calliper carrier.

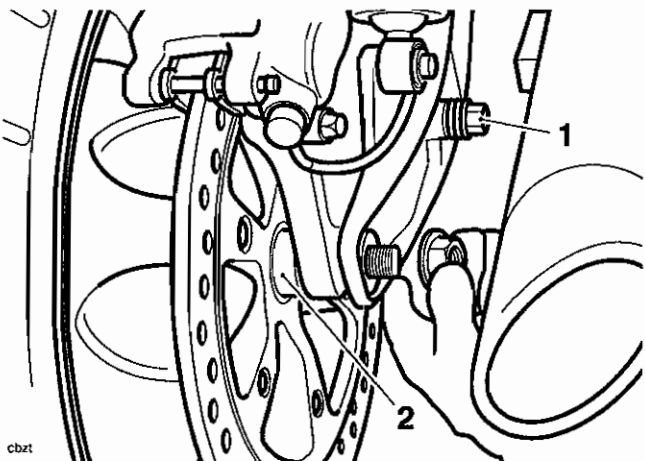

1. Torque reaction bolt
2. Spacer

4. If removing the calliper completely, disconnect the brake hose. Otherwise, leave the hose attached.

Warning

Do not allow the caliper to hang on the brake hoses as this may damage the hoses and could lead to reduced brake efficiency causing loss of motorcycle control and an accident.

5. As an assembly, manoeuvre the calliper and carrier until it is clear of the brake disc and wheel, collecting the spacer once it is freed from the caliper carrier.

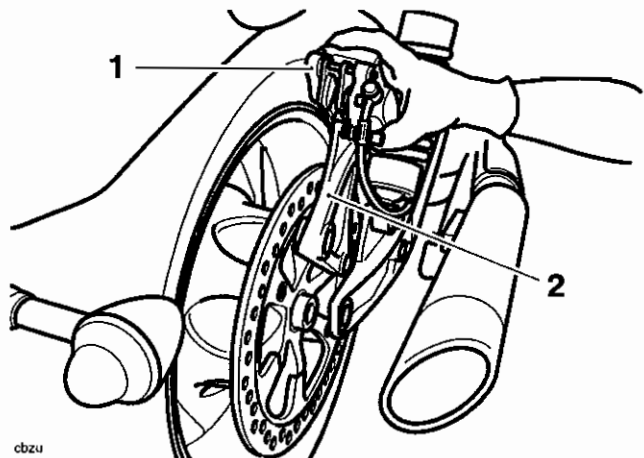

1. Caliper
2. Caliper carrier

6. Remove both 'R' clips from the pad retaining pin. Then remove the pin.

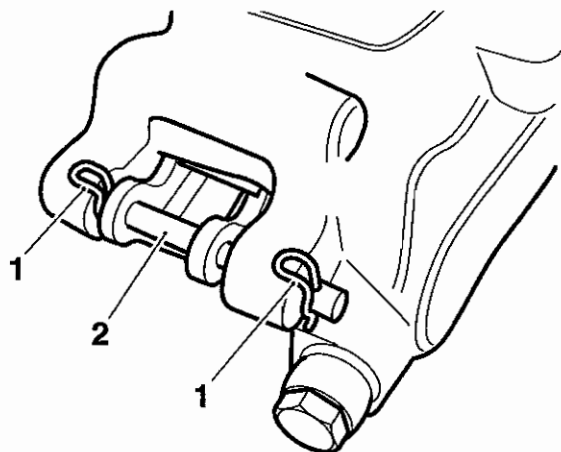

1. 'R' Clips
2. Pad retaining pin

7. Remove the brake pads and inspect for damage or wear beyond the service limit.
8. Remove the anti-rattle spring and inspect for damage.

Installation

Warning

Never use mineral based grease in any part of the braking system or in any area where contact with the braking system is possible. Mineral based grease will damage the hydraulic seals in the calipers and master cylinders. Damage caused by mineral based grease may reduce braking efficiency resulting in loss of motorcycle control and an accident.

Caution

Brake fluid will be displaced as the caliper pistons are compressed. To prevent body damage, ensure that the displaced fluid does not come into contact with any part of the bodywork or the rear wheel.

1. If fitting new pads, use hand pressure to compress the caliper pistons fully into their bores.
2. Install the anti-rattle spring into the caliper.

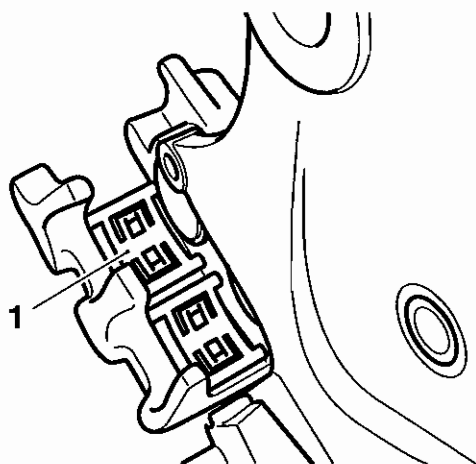

cbzv

1. Anti rattle spring

3. Renew the brake pads as a pair or, if both pads are in a serviceable condition, clean the pad grooves before fitting them.

Warning

Do not apply more than a minimum coating of grease to the pad retaining pins. Excess grease may contaminate the brake pads, hydraulic seals and discs causing reduced braking efficiency and an accident.

4. Lubricate the pad retaining pin using a minimum amount of proprietary high temperature 'Copperslip' type grease. Refit the pin and retain with both 'R' clips.
5. Position the spacer between the wheel hub and caliper carrier.

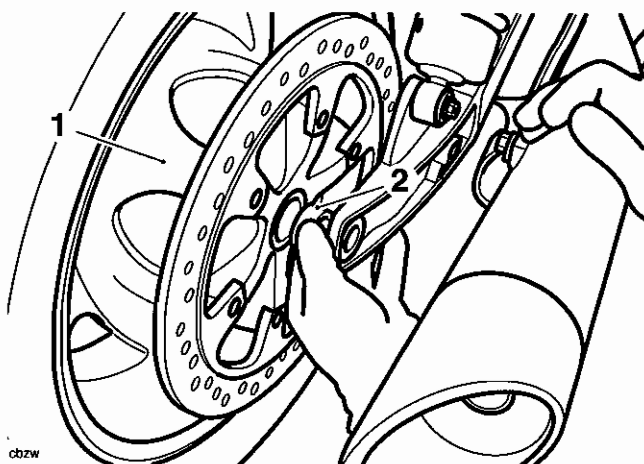

cbzw

1. Wheel hub

2. Spacer

6. Position the caliper and carrier over the disc ensuring both pads are correctly aligned either side of the disc.
7. Align the caliper carrier with the wheel spindle, spacer and swinging arm. Once in alignment, push the wheel spindle through the spacer and caliper carrier.
8. Align the caliper carrier to the torque reaction fixing point. Once in alignment, fit the torque reaction bolt.
9. Tighten the wheel spindle nut to **110 Nm** and the torque reaction bolt to **69 Nm**.

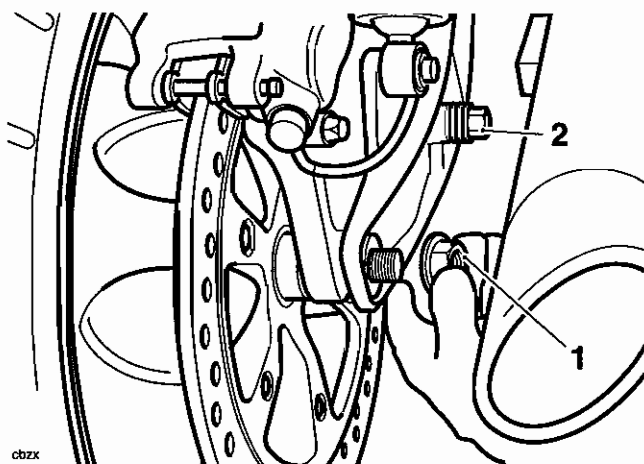

cbzx

1. Wheel spindle nut

2. Torque reaction bolt

10. If previously disconnected, incorporating new washers to each side of the union, fit and tighten the brake union bolt to **25 Nm**.

Brakes

11. If the brake hose has been disconnected, bleed the rear brake as described on page 15.20.
12. Pump the brake pedal to correctly position the caliper pistons.

Warning

Use only D.O.T. 4 specification brake fluid as listed in the general information section of this manual. The use of brake fluids other than those D.O.T. 4 fluids listed in the general information section may reduce the efficiency of the braking system leading to loss of motorcycle control and an accident. Observe the brake fluid handling warnings given earlier in this section of the manual.

13. Check the brake fluid level and top-up as required with new DOT 4 fluid.
14. Check the operation of the rear brake. Rectify as necessary.

Warning

It is dangerous to operate the motorcycle with defective brakes and you must have your authorised Triumph Dealer take remedial action before you attempt to ride the motorcycle again. Failure to take remedial action may reduce braking efficiency leading to loss of motorcycle control and an accident.

Rear Brake Caliper

Note:

- The seals and pistons of the rear calliper are not serviceable items. Should a fault occur in the caliper, the complete caliper must be renewed.

Rear Brake Disc

Wear

Warning

Before starting work, ensure the motorcycle is stabilised and adequately supported. This will help prevent it from falling and causing injury to the operator or damage to the motorcycle.

1. Replace any brake disc if worn beyond the service limit or exceeds the disc run-out limit.

| Rear Disc Thickness | |
|---------------------|--------|
| Standard | 7.5 mm |
| Service limit | 6.5 mm |

| Disc Run-out | |
|---------------|---------|
| Service limit | 0.15 mm |

Measure disc run out using an accurate dial gauge mounted on a surface plate.

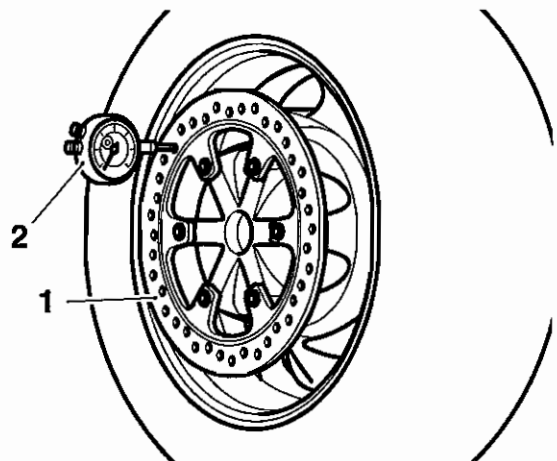

cbzy

1. Disc
2. Dial Gauge

Removal



Before starting work, ensure the motorcycle is stabilised and adequately supported. This will help prevent it from falling and causing injury to the operator or damage to the motorcycle.

1. Remove the rear wheel as described on page 16.8.
2. Support the wheel on blocks as illustrated to avoid damage to the wheel centre.
3. Remove and discard the disc securing bolts. Detach the disc.

Installation

1. Locate the disc to the wheel.
2. Fit new securing bolts and tighten to **22 Nm**.
3. Refit the wheel as described on page 16.9.
4. Check the operation of the rear brake. Rectify as necessary.



It is dangerous to operate the motorcycle with defective brakes and you must have your authorised Triumph Dealer take remedial action before you attempt to ride the motorcycle again. Failure to take remedial action may reduce braking efficiency leading to loss of motorcycle control and an accident.

Rear Master Cylinder

Removal



Before starting work, ensure the motorcycle is stabilised and adequately supported. This will help prevent it from falling and causing injury to the operator or damage to the motorcycle.

1. Remove the seat and disconnect the battery negative (black) lead first.



To prevent paint damage, do not spill brake fluid onto any area of the bodywork. Spilled brake fluid will damage paintwork.

2. Drain the fluid from the master cylinder by bleeding the system at the rear caliper until all fluid has been expelled.
3. Remove the master cylinder heel guard.

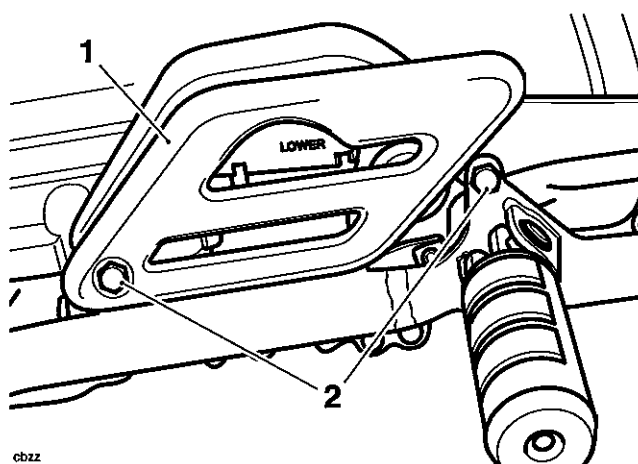

cbzz

1. Heel guard
2. Heel guard fixings

Brakes

4. Remove the clip from the brake pedal clevis pin. Remove the clevis pin.

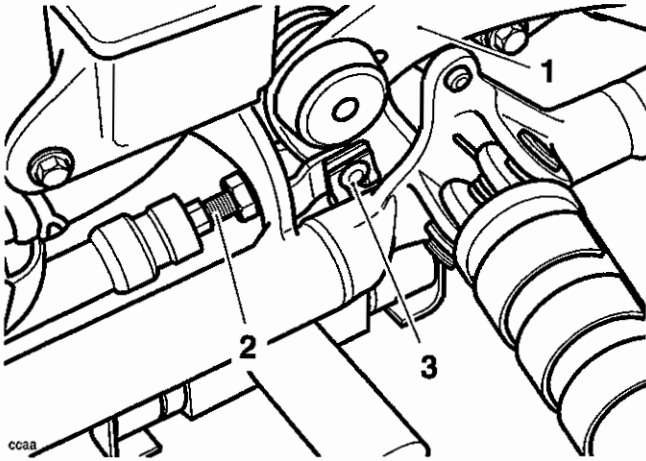

1. Pedal
2. Pushrod
3. Clevis

5. Disconnect the feed hose from the brake fluid reservoir at the master cylinder.

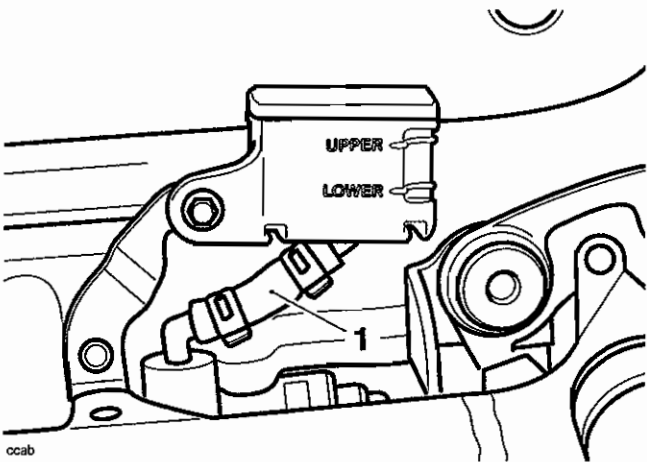

1. Reservoir feed hose

6. Disconnect the brake pipe from the master cylinder (discard the sealing washers).

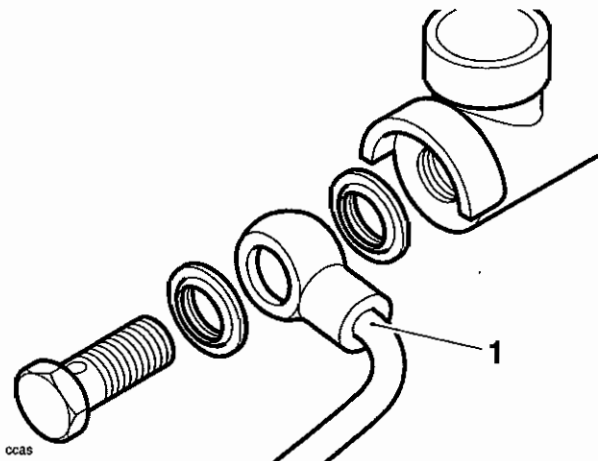

1. Brake pipe

7. Release the bolts securing the master cylinder to the footrest mounting bar. Detach the master cylinder.

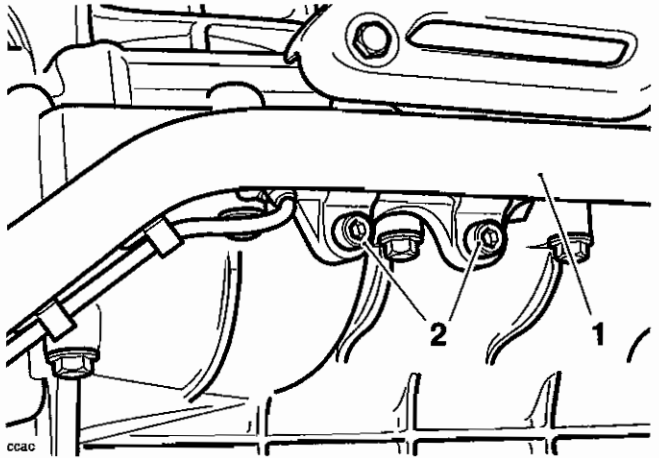

1. Footrest mounting bar
2. Master cylinder bolts

Disassembly

1. Remove the dust cover from the cylinder and pushrod.
2. Remove the circlip retaining the pushrod to the cylinder.

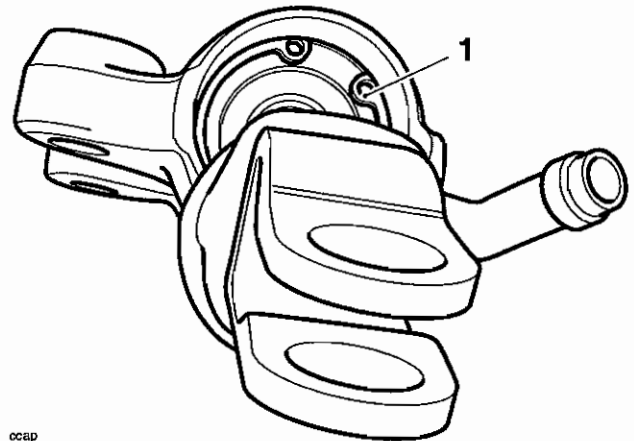

1. Circlip

- Remove the pushrod and piston set from the master cylinder bore noting the relative position of the seals and piston components.

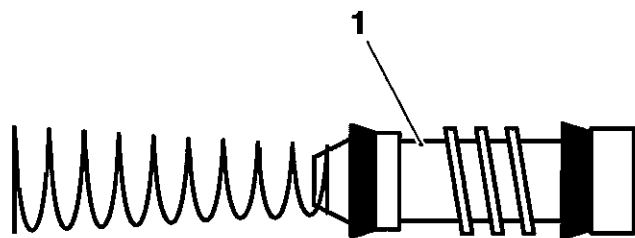

ccsq

1. Piston

Inspection

- Check the following for wear, damage, cracks or deterioration:

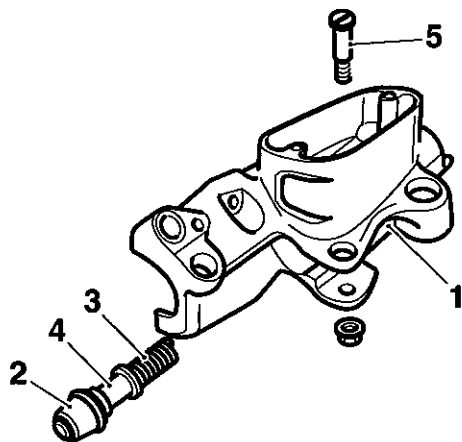

obzl

- Cylinder bore
- Dust cover
- Spring
- Piston
- Pivot bolt

- Examine the pushrod for distortion and other damage. Replace as necessary.

Assembly

Warning

Never use mineral based grease in any part of the braking system or in any area where contact with the braking system is possible. Mineral based grease will damage the hydraulic seals in the calipers and master cylinders. A dangerous riding condition leading to loss of motorcycle control and an accident could result from use of mineral grease.

- Lubricate the piston and cylinder with new, clean brake fluid.

Warning

Ensure that the piston and piston seal are fitted facing the same way as noted during removal. A dangerous riding condition leading to loss of motorcycle control and an accident could result from incorrect assembly of the master cylinder.

- Fit the new piston and seal set into the master cylinder.

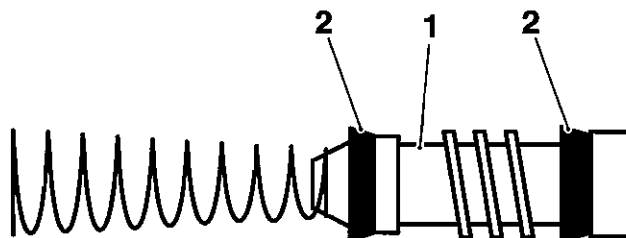

ccao

- Piston
- Seals (in correct orientation)

- Apply a small amount of brake grease to the pushrod.
- Install the pushrod in the master cylinder, compress the spring and retain the assembly with a new circlip.

Brakes

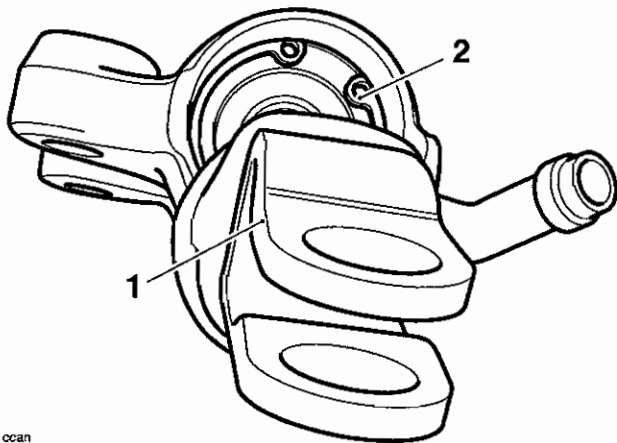

ccan

1. Pushrod
2. Circlip
5. Refit the master cylinder boot.

Installation

1. Position the master cylinder to the footrest mounting bar.
2. Secure with two new bolts, tightening to 27 Nm.
3. Incorporating new washers to either side of the union, fit the brake pipe. Tighten the union bolt to 25 Nm.
4. Position the reservoir hose to the master cylinder. Retain the hose by positioning the clips as shown below.

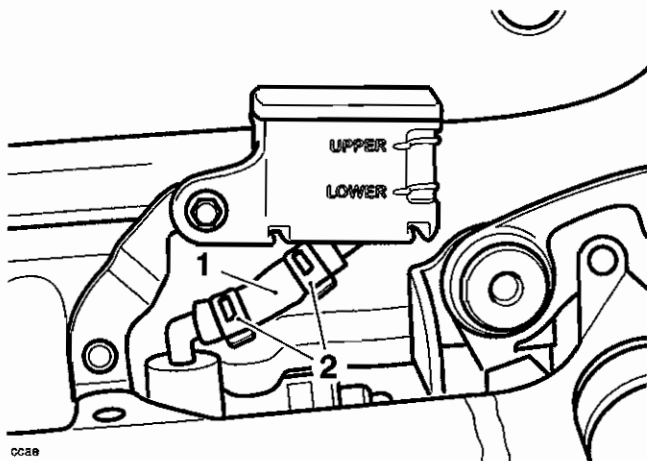

ccae

1. Reservoir hose
2. Clips

5. Align the brake pedal with the pushrod, engage the clevis and retain it with the clip. Ensure the clip is fitted as shown below.

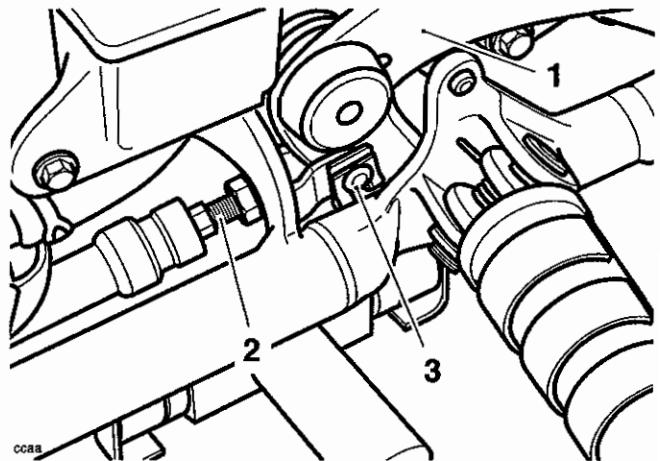

ccas

1. Pedal
2. Pushrod
3. Clevis



Warning

Use only D.O.T. 4 specification brake fluid as listed in the general information section of this manual. The use of brake fluids other than those D.O.T. 4 fluids listed in the general information section may reduce the efficiency of the braking system leading to loss of motorcycle control and an accident. Observe the brake fluid handling warnings given earlier in this section of the manual.

6. Refit the heel guard tightening the fixings to 9 Nm.

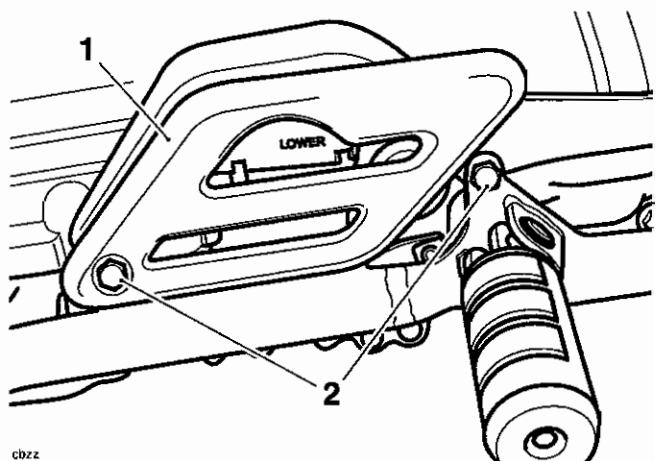

cbzz

1. Heel guard
2. Fixings

7. Fill and bleed the rear brake system as described on page 15.20.
8. Reconnect the battery positive, (red) lead first.
9. Fit the seat.
10. Check the operation of the rear brake. Rectify as necessary.

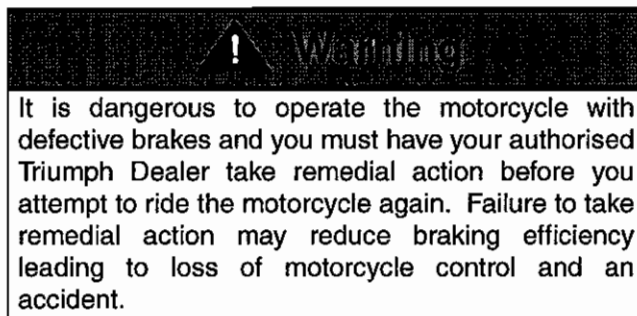

This page intentionally left blank

16 Wheels/Tyres

Table of Contents

| | |
|---|-------|
| Exploded view - Front Wheel | 16.2 |
| Exploded View - Rear Wheel and Cush Drive | 16.3 |
| Tyres..... | 16.4 |
| Tyre Pressures | 16.4 |
| Tyre Wear/Wheel Inspection..... | 16.4 |
| Minimum Recommended Tread Depth..... | 16.5 |
| Important Tyre Information | 16.5 |
| Front Wheel | 16.6 |
| Removal | 16.6 |
| Installation | 16.7 |
| Rear Wheel..... | 16.8 |
| Removal | 16.8 |
| Installation | 16.9 |
| Cush Drive | 16.10 |
| Removal | 16.10 |
| Installation | 16.11 |

Wheels/Tyres

Exploded view - Front Wheel

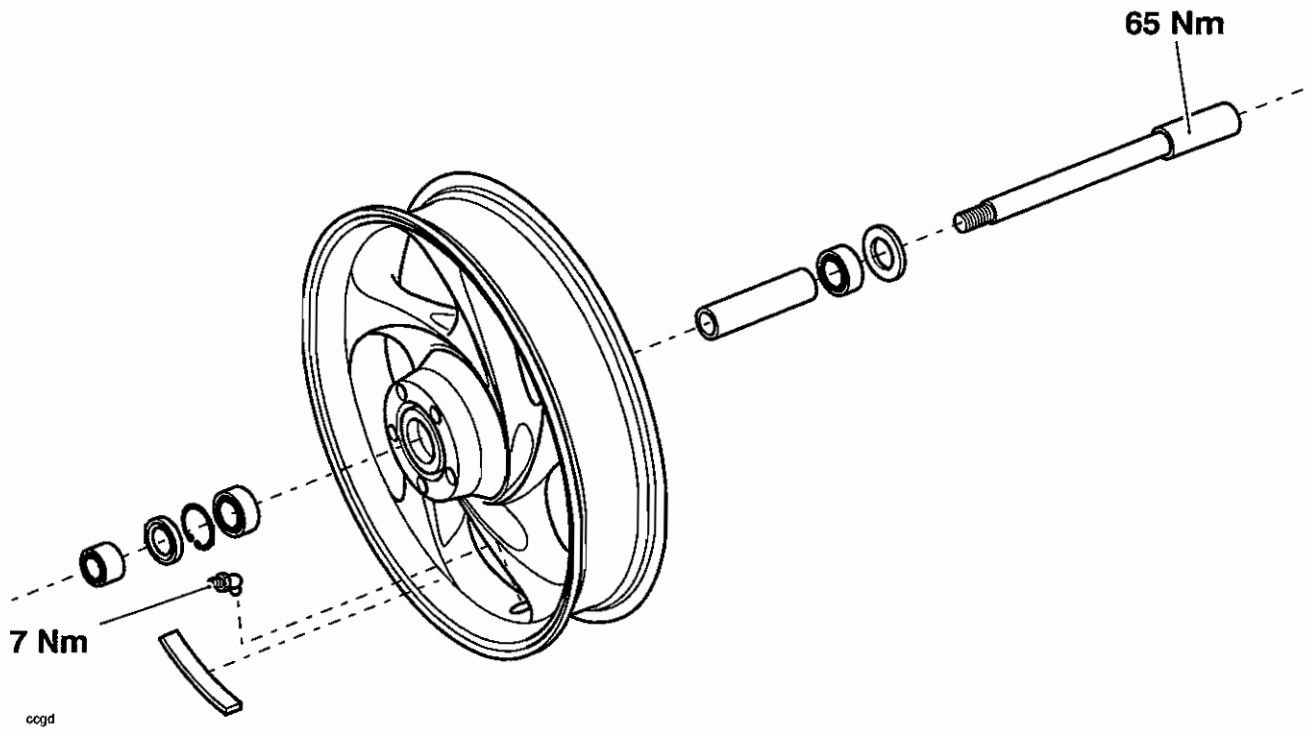

Exploded View - Rear Wheel and Cush Drive

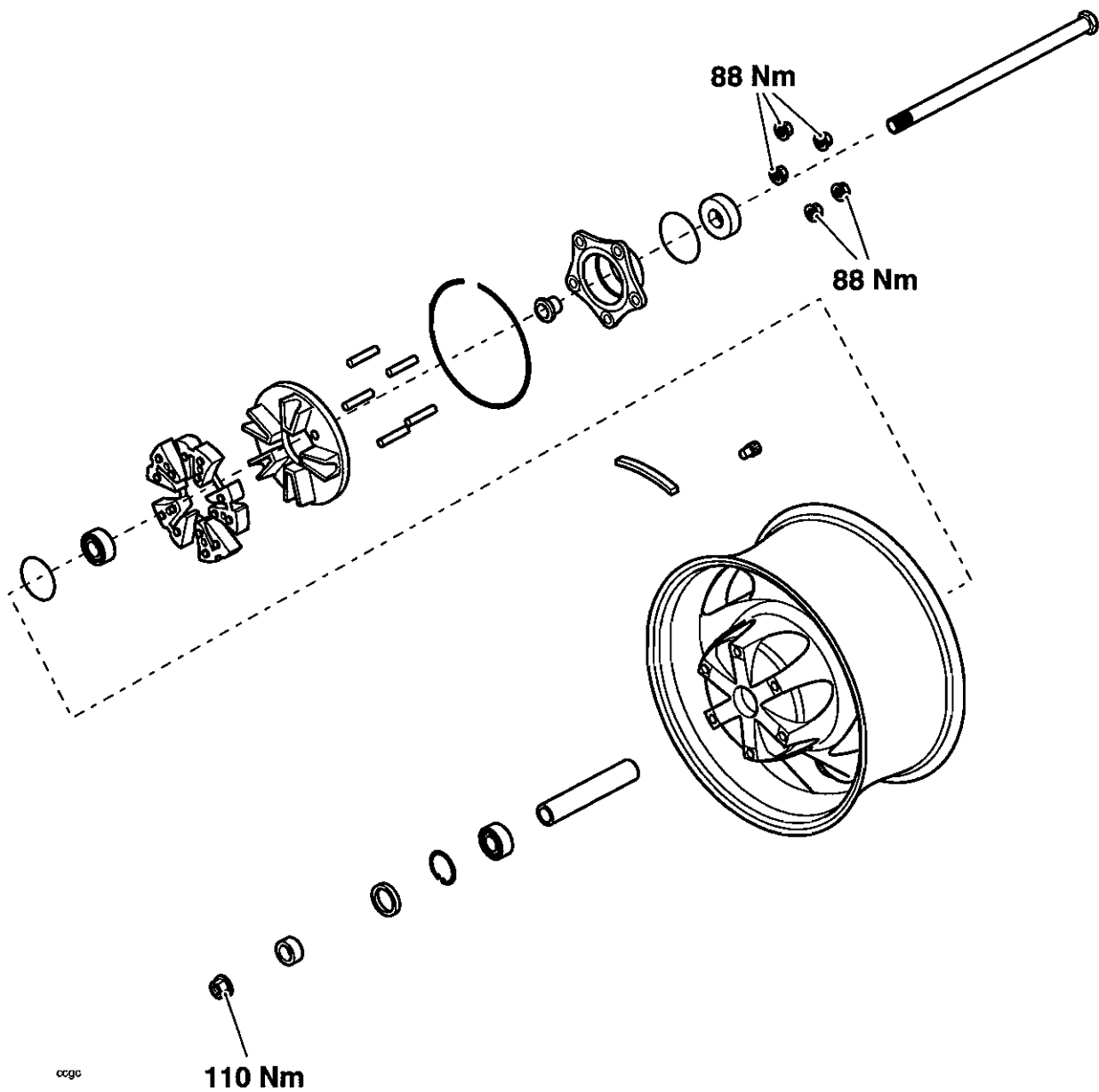

Wheels/Tyres

Tyres

This model is equipped with tubeless tyres, valves, and wheel rims. Only tyres marked 'TUBELESS' and tubeless type tyre valves mounted on rims marked 'SUITABLE FOR TUBELESS TYRES' can be used.

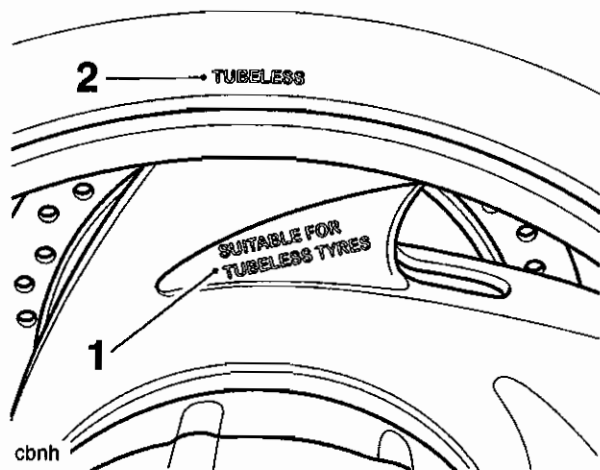

1. Wheel Marking
2. Tyre Marking

Warning

Tyres that have been used on a rolling road dynamometer may become damaged. In some cases, the damage may not be visible on the external surface of the tyre. Tyres must be replaced after such use as continued use of a damaged tyre may lead to instability, loss of motorcycle control and an accident.

Tyre Pressures

The correct tyre pressures for Rocket III are shown in the table below. The tyre pressures must always be checked and adjusted when the tyres are cold.

| Loading condition | Front | Rear |
|------------------------------|--------------------------------------|--------------------------------------|
| Rider only | 2.34 Bar (34 lb/in ²) | 2.90 Bar (42 lb/in ²) |
| Rider, passenger and luggage | 2.34 Bar (34 lb/in ²) | 2.90 Bar (42 lb/in ²) |

Warning

Correct tyre inflation pressures will provide maximum stability, rider comfort and tyre life. Tyre pressures must be checked according to the scheduled maintenance chart, when the tyres are cold, and adjusted as necessary.

Incorrect tyre inflation pressures will cause abnormal tread wear and instability problems that may lead to loss of motorcycle control and an accident. Under-inflation may result in the tyre slipping on, or coming off the rim. Over-inflation will cause instability and accelerated tread wear. Both conditions are dangerous as they may cause loss of motorcycle control and an accident.

Tyre Wear/Wheel Inspection

As the tyre tread wears down, the tyre becomes more susceptible to puncture and failure. It is estimated that 90% of all tyre failures occur during the last 10% of tread life (90% worn). It is false economy and unsafe to use tyres until they are worn to their minimum.

All tyres are fitted with tread wear indicators. When the tyre becomes worn down as far as the top of a tread wear indicator, the tyre is worn beyond its service life and must be replaced. Attention must also be paid to the legal limits for tread wear, which differ from country to country. Tyres that have worn to the legal limit in the country or region in which the motorcycle is operated must be replaced, even if tread wear has not yet reached the level of the tread wear indicators.

In accordance with the scheduled maintenance chart, measure the depth of the tread with a depth gauge, and replace any tyre that has worn to, or beyond the minimum allowable tread depth.

Inspect wheels for cracks, splits and kerb damage. Always replace wheels that are suspected of having become damaged.

Warning

Operation with excessively worn tyres is hazardous and will adversely affect traction, stability and handling which may lead to loss of motorcycle control or an accident.

When tubeless tyres become punctured, leakage is often very slow. Always inspect tyres very closely for punctures. Check the tyres for cuts, imbedded nails or other sharp objects. Check the rims for dents or deformation. Operation with damaged or defective wheels or tyres is dangerous and loss of motorcycle control or an accident could result. Always consult your Triumph dealer for tyre replacement, or for a safety inspection of the tyres.

Minimum Recommended Tread Depth

In accordance with the scheduled maintenance chart, measure the depth of the tread with a depth gauge, and replace any tyre that has worn to, or beyond the minimum legally allowable tread depth.

In countries where there is no legal minimum tread depth, Triumph recommends the following;

| Speed | Minimum Tread Depth |
|-------------------------|---|
| Under 130 km/h (80 mph) | 2 mm (0.08 in) |
| Over 130 km/h (80 mph) | Rear 3 mm (0.12 in) Front 2 mm (0.08 in) |

Warning

Triumph motorcycles must not be operated above the legal road speed limit except in authorised closed course conditions.

Warning

Only operate this Triumph motorcycle at high speed in closed-course on-road competition or on closed course race tracks. High speed operation should only then be attempted by riders who have been instructed in the techniques necessary for high speed riding and are familiar with the motorcycle's characteristics in all conditions. High speed operation in any other circumstances is dangerous and may lead to loss of motorcycle control and an accident.

Important Tyre Information

All Triumph motorcycles are carefully and extensively tested in a range of riding conditions to ensure that the most effective tyre combinations are approved for use on each model. It is essential that approved tyre combinations are used when purchasing replacement tyres as the use of non approved tyres or approved tyres in non approved combinations may lead to motorcycle instability. Always refer to the owner's handbook data section for details of approved tyres and tyre combinations.

Warning

If a tyre sustains a puncture, the tyre must be replaced. Failure to replace a punctured tyre, or operation with a repaired tyre can lead to instability, loss of control or an accident.

Warning

Never use an inner tube to repair a punctured tyre. The rough surface inside the tyre can chafe the tube leading to instability, rapid deflation, loss of motorcycle control and an accident.

Warning

Do not install tube-type tyres on tubeless rims. The bead will not seat and the tyres could slip on the rims, causing tyre deflation that may result in a loss of motorcycle control and an accident.

Warning

The use of tyres other than those listed in the specification section of the owner's handbook may adversely affect handling leading to loss of motorcycle control or an accident. Use the recommended tyre options only in the combinations given in the owner's handbook. Do not mix tyres from different manufacturers or tyres from the same manufacturer but from another option.

Warning

Accurate wheel balance is important for safe, stable handling of the motorcycle. Do not remove or change any wheel balance weights. Incorrect wheel balance may cause instability leading to loss of motorcycle control and an accident.

When wheel balancing is required, such as after tyre replacement, see your authorised Triumph dealer.

Only use self-adhesive weights. Clip-on weights will damage the wheel and tyre potentially resulting in tyre deflation, loss of motorcycle control and an accident.

Warning

When replacement tyres are required, consult your authorised Triumph dealer who will arrange for the tyres to be fitted according to the tyre manufacturers instructions.

When tyres are replaced, allow time for the tyre to seat itself to the rim (approximately 24 hours). During this seating period, ride cautiously as an incorrectly seated tyre could cause loss of motorcycle control or an accident. Initially, the new tyre will not produce the same handling characteristics as the worn tyre and the rider must allow adequate riding distance (approximately 100 miles) to become accustomed to the new handling characteristics.

After both 24 hours and 100 miles, the tyre pressures should be checked and adjusted and the tyre examined for correct seating and rectified as necessary.

Use of a motorcycle when not accustomed to its handling characteristics, with incorrect tyre pressures or an incorrectly seated tyre is dangerous and may lead to loss of motorcycle control and an accident.

Front Wheel

Removal

Warning

Before starting work, ensure the motorcycle is stabilised and adequately supported. This will help prevent it from falling and causing injury to the operator or damage to the motorcycle.

1. Raise and support the front of the motorcycle.
2. Detach both brake callipers.

Note:

- It is not necessary to disconnect the brake hoses.

Warning

Do not allow the calipers to hang on the brake hoses as this may damage the hoses. Damaged hoses could cause brake failure leading to loss of control and an accident.

3. Slacken both pinch bolts at the lower end of the left hand fork.

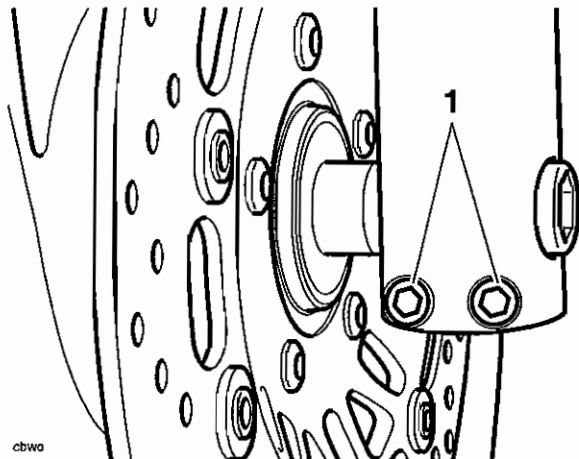

1. Fork pinch bolts

- Release and remove the wheel spindle which is threaded into the right hand fork.

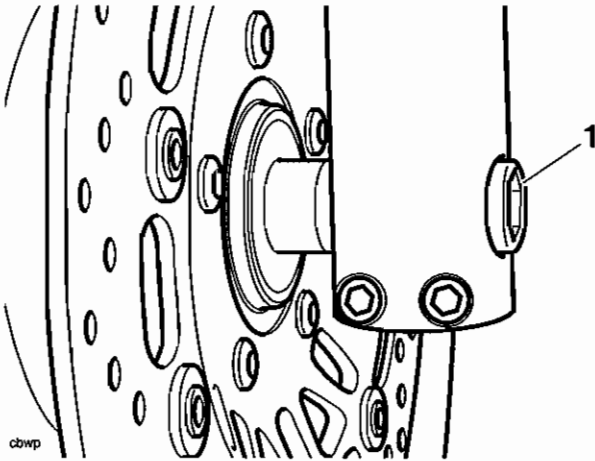

1. Wheel spindle

- Remove the wheel, recovering the spacer from the right hand side.

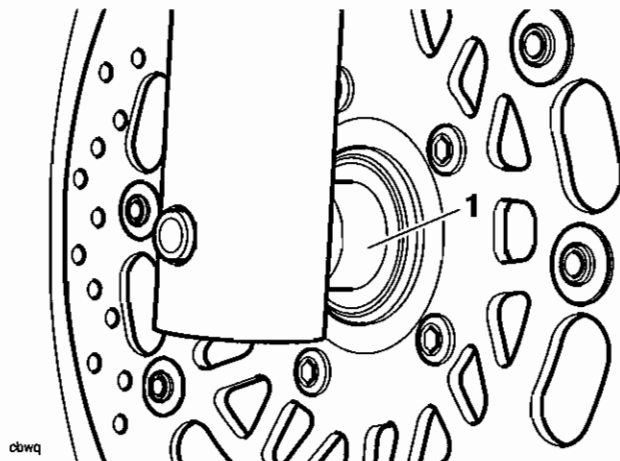

1. Spacer

- Place the wheel on wooden blocks to prevent damage to the brake discs.

Warning

Do not allow the wheel to rest on either brake disc as this may damage the disc leading to loss of motorcycle control and an accident.

Caution

To prevent wheel and wheel bearing damage, ensure dirt and debris are not allowed to enter the wheel bearings.

- Thoroughly clean all components and inspect for wear or damage.

Installation

- Lightly smear the spacer with grease and locate in the right hand side of the hub.

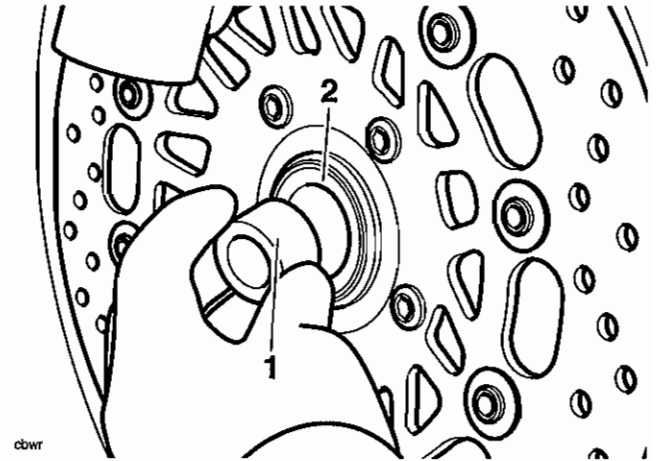

1. Spacer

2. Hub

- Position the wheel between the forks.
- Raise the wheel until it is in alignment with the spindle holes in both forks. Take care to not dislodge the spacer.
- Refit the wheel spindle from the left hand side and tighten to **65 Nm**.
- Check that the brake disc is centrally located to the caliper on the left hand side. If not, apply gentle pressure to the fork to ensure the disc is centred with the caliper.
- Maintaining the above position, tighten the fork pinch bolts to **22 Nm**.
- Thoroughly clean and degrease the brake discs.
- Fit the brake calipers, tightening the mounting bolts to **40 Nm**.
- Check the operation of the front brake. Rectify as necessary.

Warning

It is dangerous to operate the motorcycle with defective brakes and you must have your authorised Triumph Dealer take remedial action before you attempt to ride the motorcycle again. Failure to take remedial action may reduce braking efficiency leading to loss of motorcycle control and an accident.

Wheels/Tyres

Rear Wheel

Removal

Warning

Before starting work, ensure the motorcycle is stabilised and adequately supported. This will help prevent it from falling and causing injury to the operator or damage to the motorcycle.

1. Raise and support the rear of the motorcycle.
2. Release the wheel spindle nut and withdraw the spindle to a point where it clears the caliper carrier.

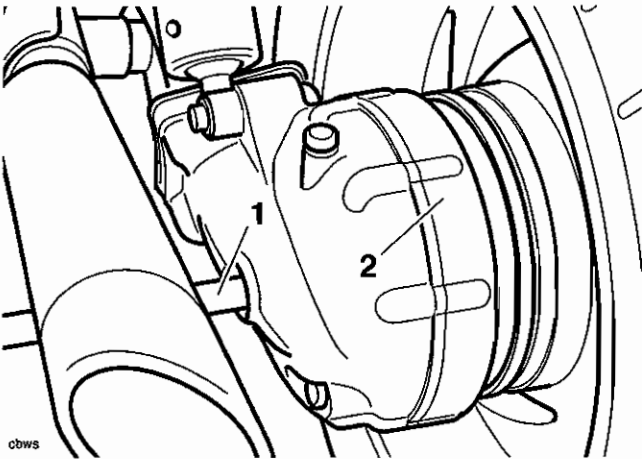

1. Wheel spindle
2. Bevel box
3. Release the torque reaction bolt from the caliper carrier.

Warning

Do not allow the caliper to hang on the brake hoses as this may damage the hoses and could lead to reduced brake efficiency causing loss of motorcycle control and an accident.

4. As an assembly, manoeuvre the caliper and carrier until it is clear of the brake disc and wheel, collecting the spacer once it is freed from the caliper carrier.

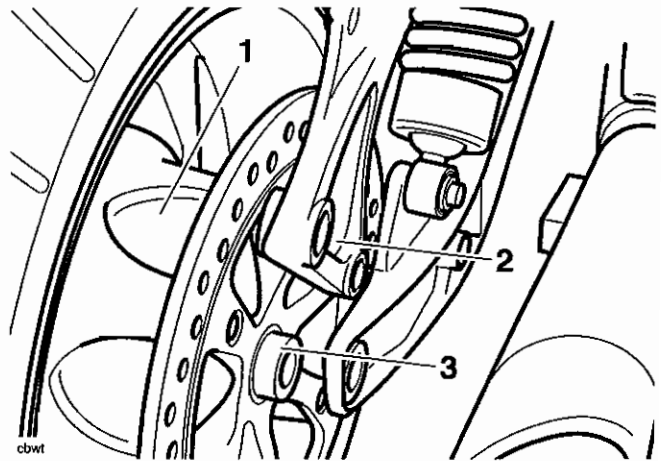

1. Wheel
2. Caliper carrier
3. Spacer

Note:

- Rest the calliper assembly on a support such that it is not allowed to hang on the brake hose.
5. Withdraw the wheel spindle completely.
 6. Gently pull the wheel towards the right hand side of the motorcycle to release it from the bevel box.

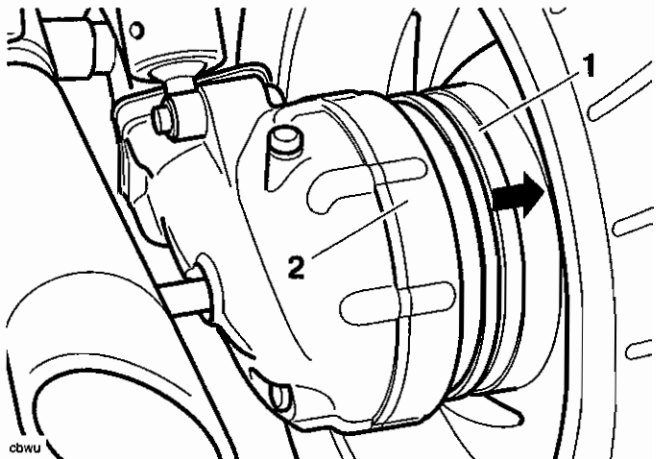

1. Wheel
2. Bevel box

7. Manoeuvre the wheel clear of the swinging arm.
8. Place the wheel on wooden blocks with the brake disc uppermost.

Installation

1. Thoroughly clean and degrease the brake disc.
2. Apply Mobil HP222 grease (or equivalent) to the wheel driven flange.
3. Position the wheel within the swinging arm.
4. Raise the wheel and engage the driven flange with the bevel box. Once the splines are engaged, push the wheel fully home.

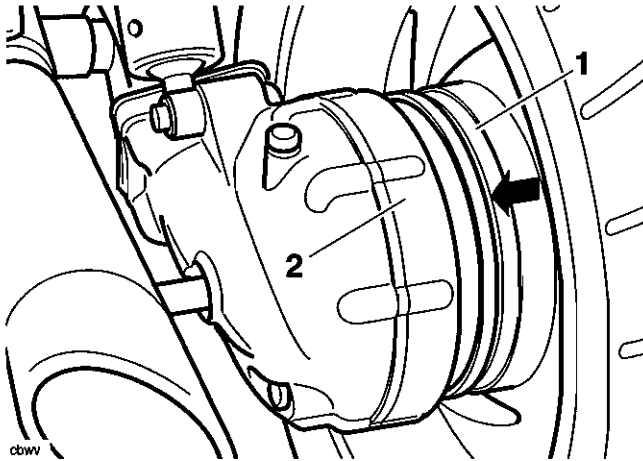

cbwv

1. Wheel
2. Bevel box

5. Fit the wheel spindle, pushing it through the wheel centre sufficient to support the wheel without preventing fitment of the spacer and caliper carrier.

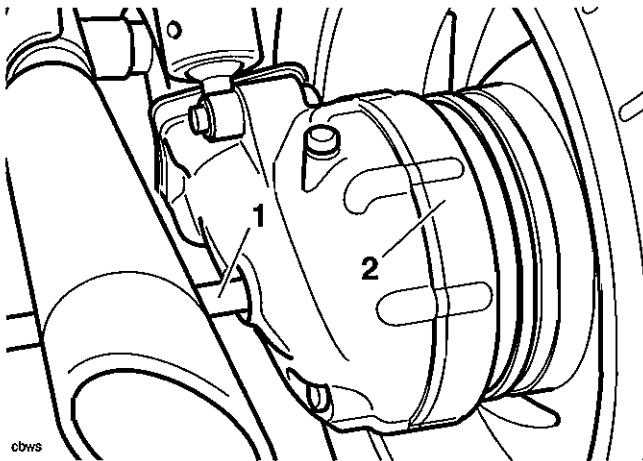

cbws

1. Wheel spindle
2. Bevel box

6. Position the caliper and carrier over the disc ensuring both brake pads are correctly aligned either side of the disc.
7. Position the spacer between the wheel and caliper carrier.

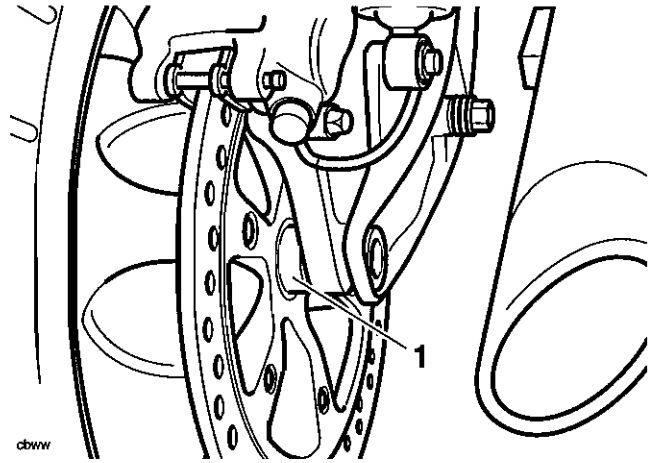

cbww

1. Spacer

8. Align the caliper carrier with the wheel spindle, spacer and swinging arm. Once in alignment, push the wheel spindle through the caliper carrier.
9. Align the caliper carrier to the torque reaction fixing point. Once in alignment, fit a new torque reaction bolt.
10. Tighten the wheel spindle nut to **110 Nm** and the torque reaction bolt to **69 Nm**.

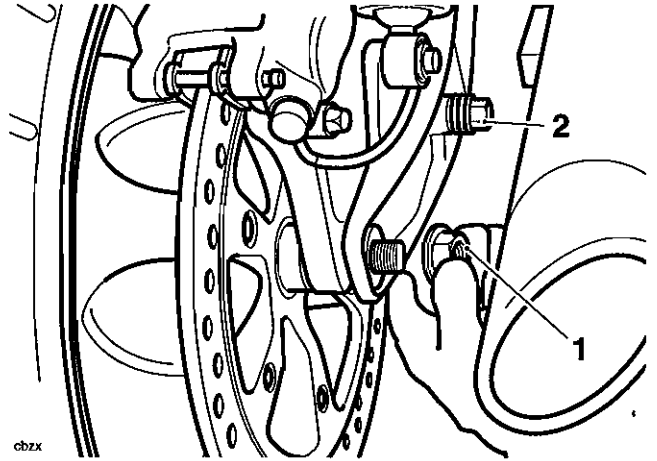

cbzx

1. Wheel spindle nut
2. Torque reaction bolt

Wheels/Tyres

11. Pump the brake pedal to correctly position the caliper pistons.
12. Check the operation of the rear brake. Rectify as necessary.

Warning

It is dangerous to operate the motorcycle with defective brakes and you must have your authorised Triumph Dealer take remedial action before you attempt to ride the motorcycle again. Failure to take remedial action may reduce braking efficiency leading to loss of motorcycle control and an accident.

Cush Drive

Removal

Warning

Before starting work, ensure the motorcycle is stabilised and adequately supported. This will help prevent it from falling and causing injury to the operator or damage to the motorcycle.

1. Remove the rear wheel as described on page 16.8.
2. Release the circlip securing the driven flange assembly to the wheel centre.

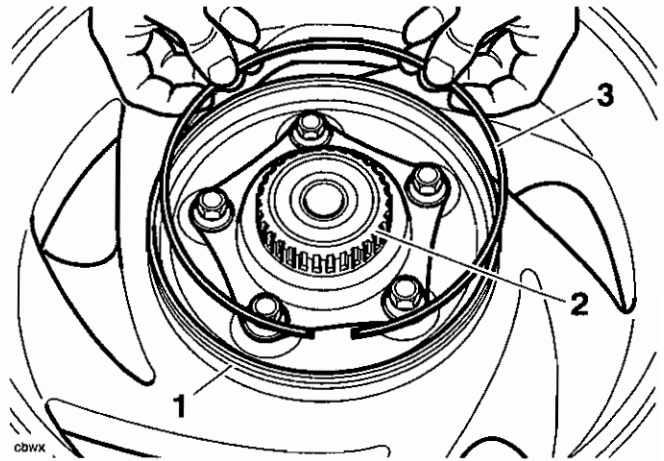

1. Wheel centre
2. Driven Flange
3. Circlip

3. Withdraw the driven flange from the wheel, recovering the spacer from the cush rubber side of the flange.

Note:

- It is not necessary to remove the drive flange nuts.

- Recover the cush drive rubbers from within the wheel.

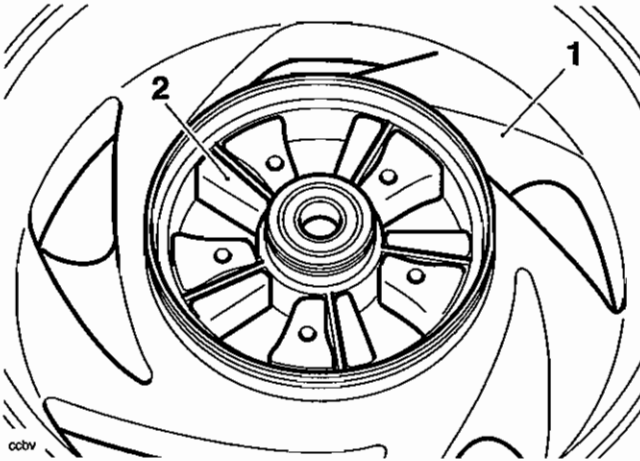

- Wheel
- Cush Drive Rubbers

Installation

- Position the cush drive rubbers within the wheel centre.
- Refit the spacer to the inside face of the driven flange.

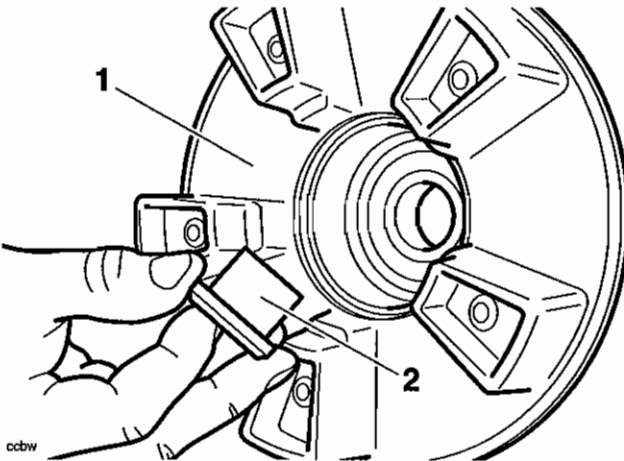

- Driven flange
- Spacer

- Locate the driven flange assembly to the wheel centre, engaging the paddles with the cush rubbers. Ensure the spacer is not displaced during assembly.

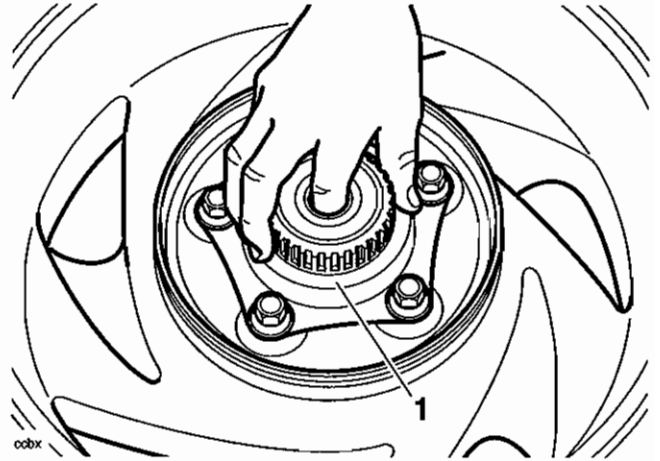

- Driven flange

- Retain the assembly with a new bold circlip.

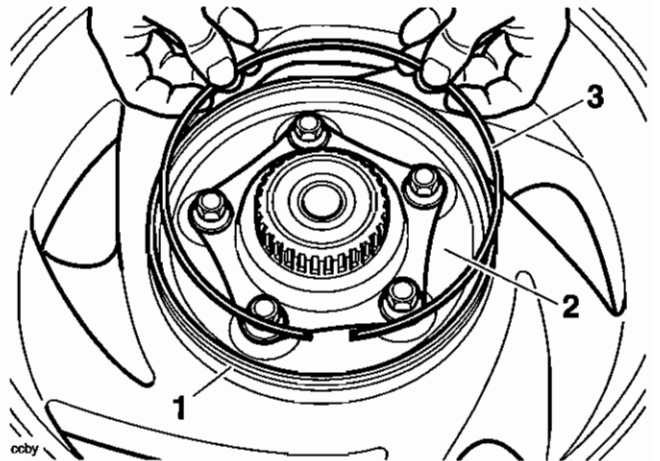

- Wheel centre
- Driven Flange
- Circlip

- Refit the rear wheel as described on page 16.8.

This page intentionally left blank

17 Frame and Bodywork

Table of Contents

| | |
|--|-------|
| Exploded View - Frame and Fixings | 17-2 |
| Exploded View - Front and Rear Mudguards | 17-3 |
| Exploded View - Front and Rear Footrests | 17-4 |
| Exploded View - Seat and Tool Kit | 17-5 |
| Exploded View - Side Panels | 17-6 |
| Exploded View - Side Stand | 17-7 |
| General Frame Inspection | 17-8 |
| Seats | 17-9 |
| Rider's seat | 17-9 |
| Seat lock | 17-9 |
| Rear Seat | 17-9 |
| Side Covers | 17-9 |
| Removal | 17-9 |
| Installation | 17-9 |
| Engine Infill Panels | 17-10 |
| Removal | 17-10 |
| Installation | 17-10 |
| Front Mudguard | 17-10 |
| Removal | 17-10 |
| Mudguard embellisher removal | 17-11 |
| Embellisher assembly | 17-11 |
| Installation | 17-11 |
| Rear Mudguard | 17-12 |
| Removal | 17-12 |
| Wiring connections | 17-12 |
| Installation | 17-13 |
| Handlebars | 17-15 |
| Removal | 17-15 |
| Installation | 17-16 |
| Side Stand | 17-17 |
| Removal | 17-17 |
| Installation | 17-17 |

Frame and Bodywork

Exploded View - Frame and Fixings

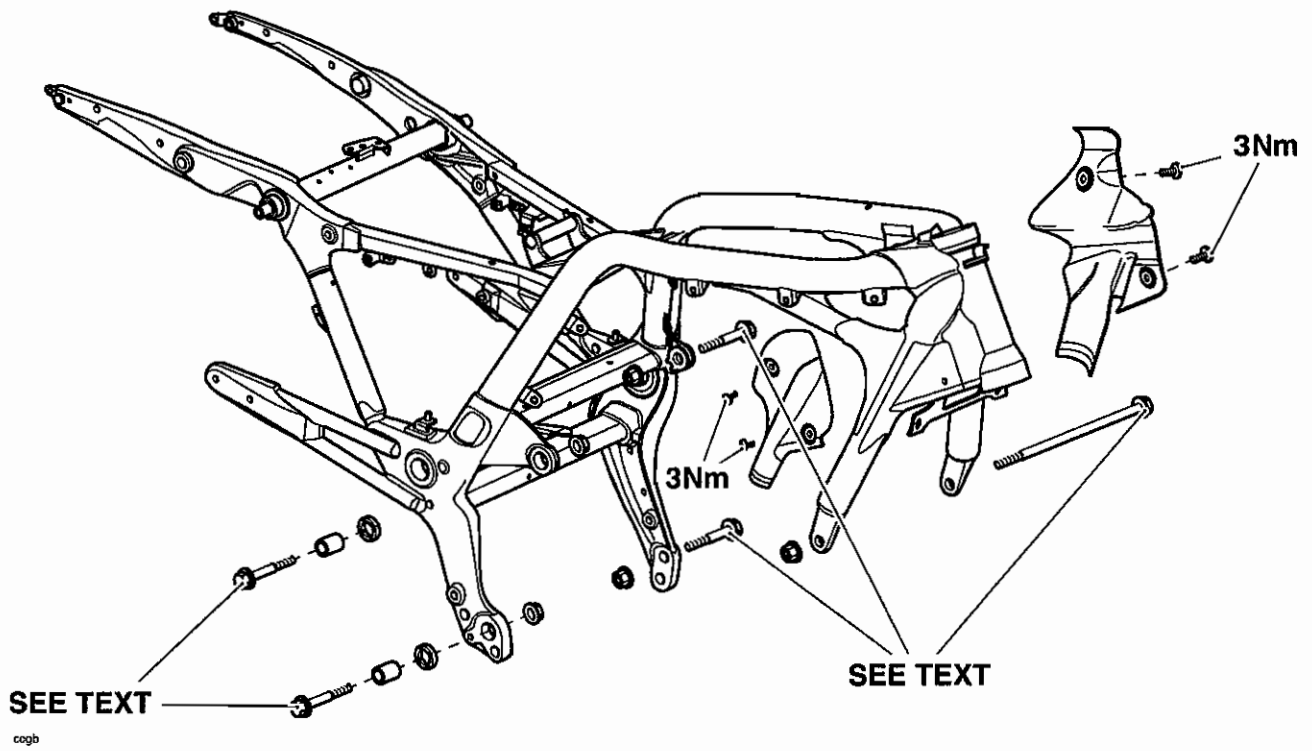

Exploded View - Front and Rear Mudguards

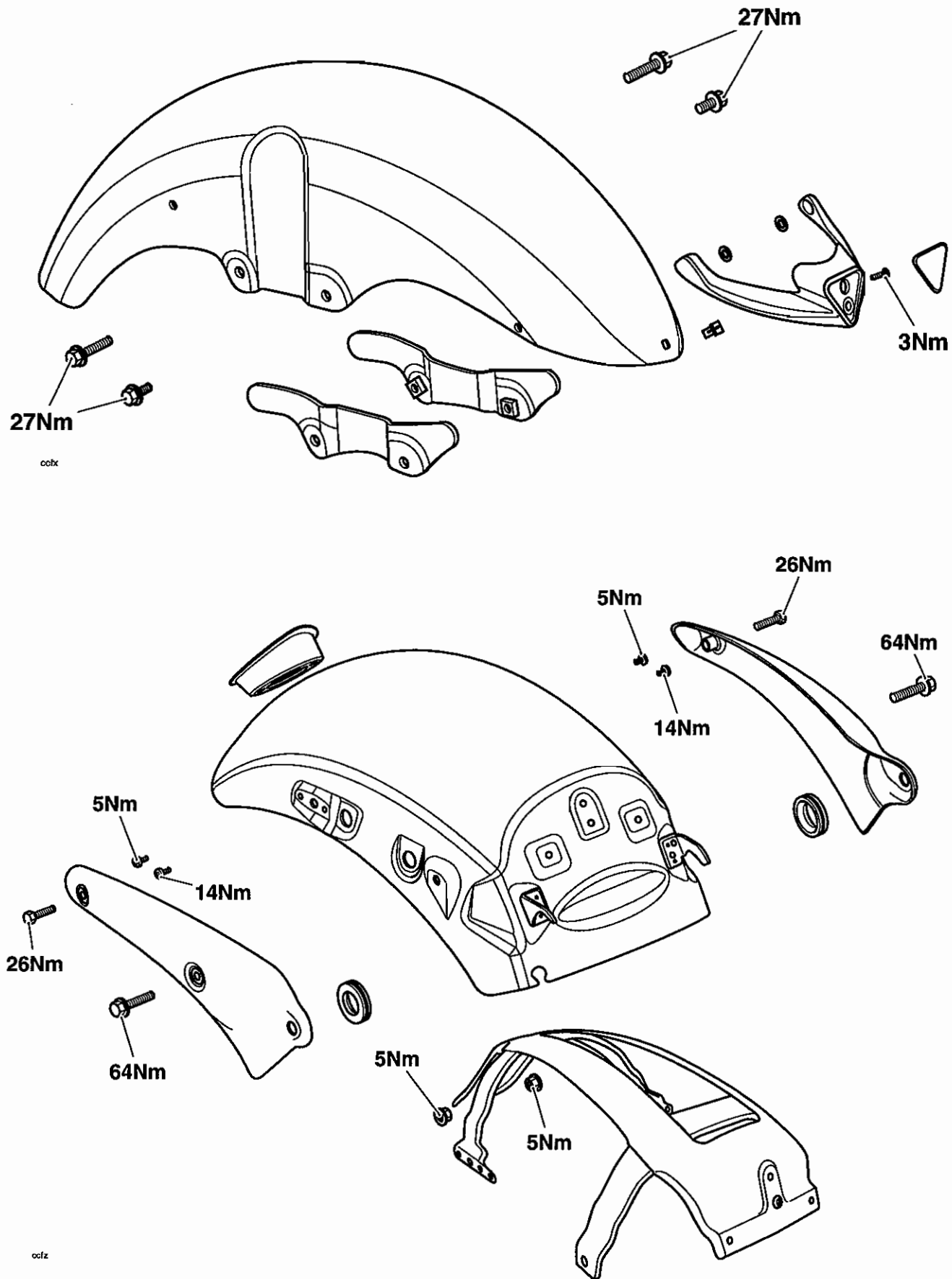

Frame and Bodywork

Exploded View - Front and Rear Footrests

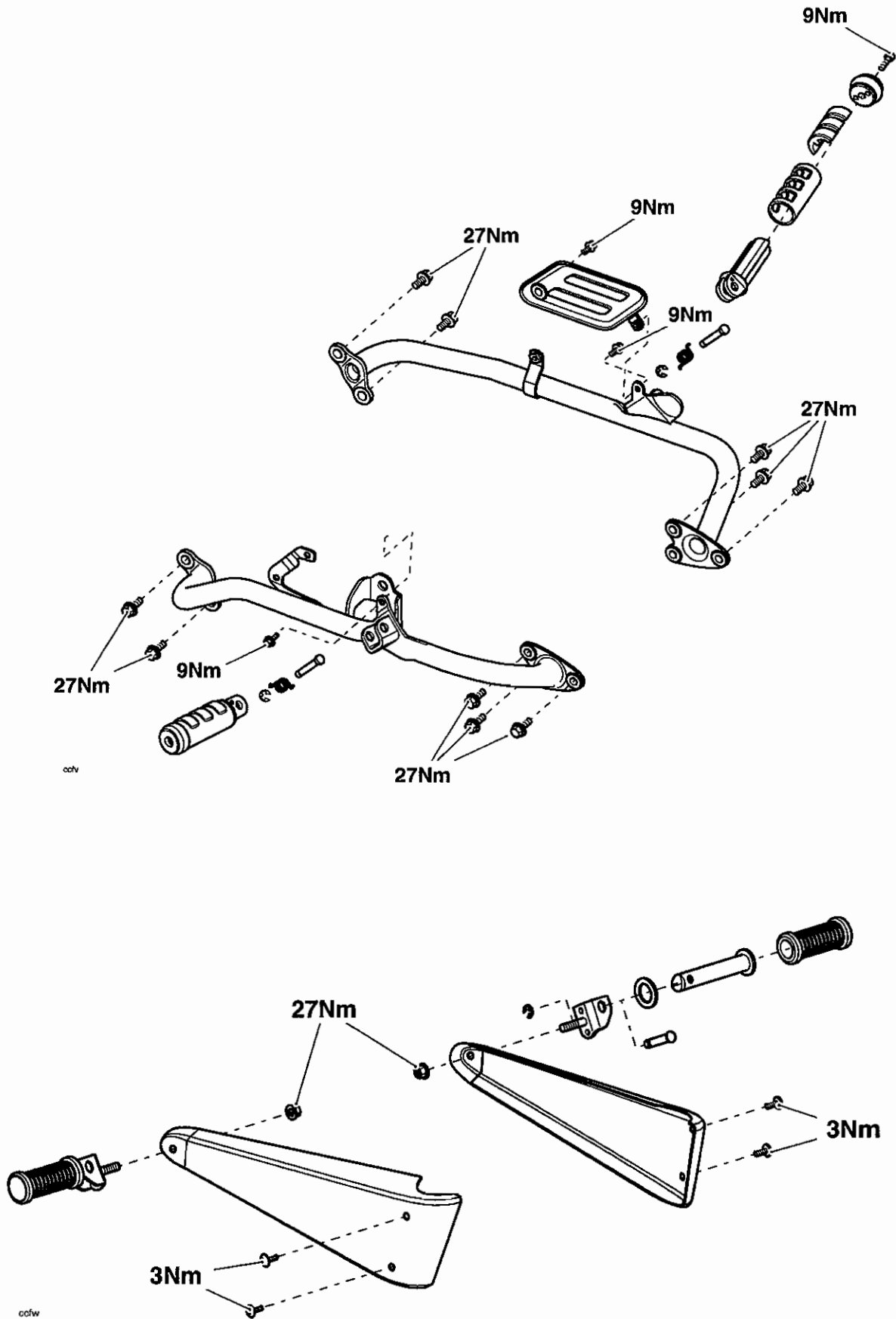

Exploded View - Seat and Tool Kit

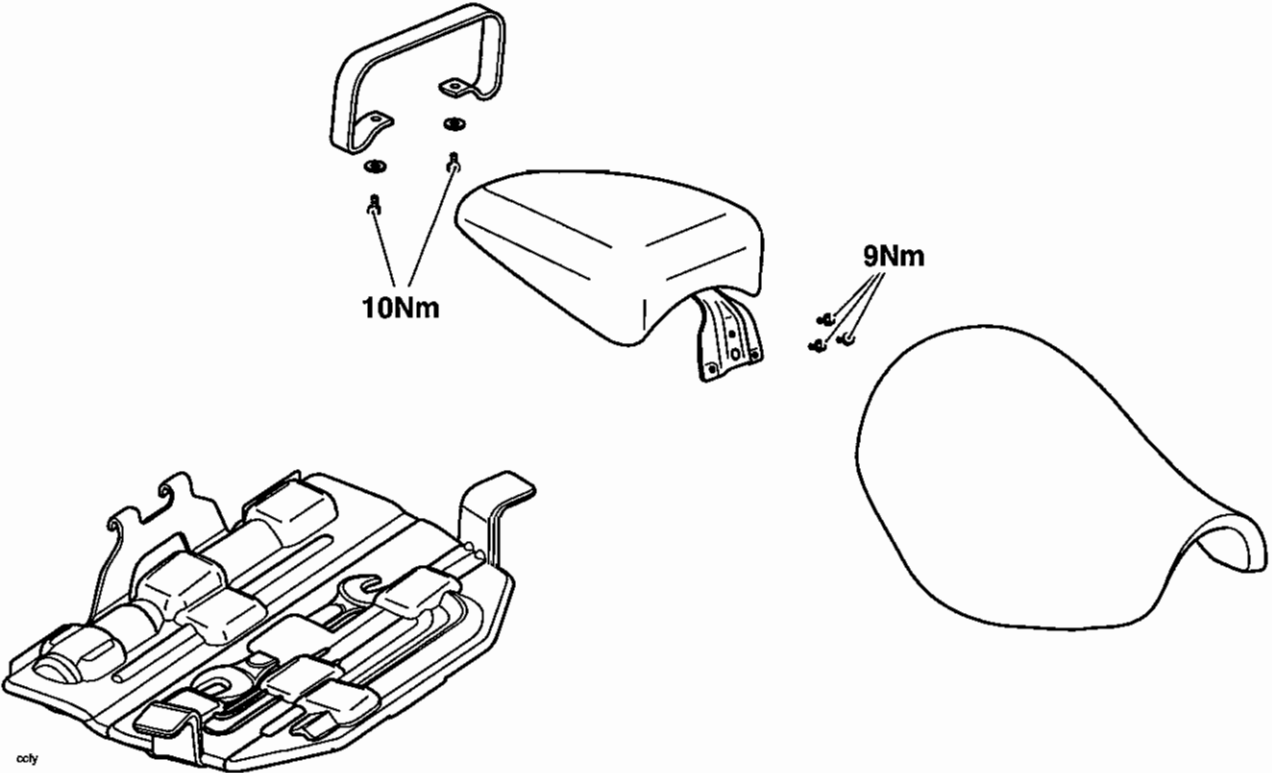

Frame and Bodywork

Exploded View - Side Panels

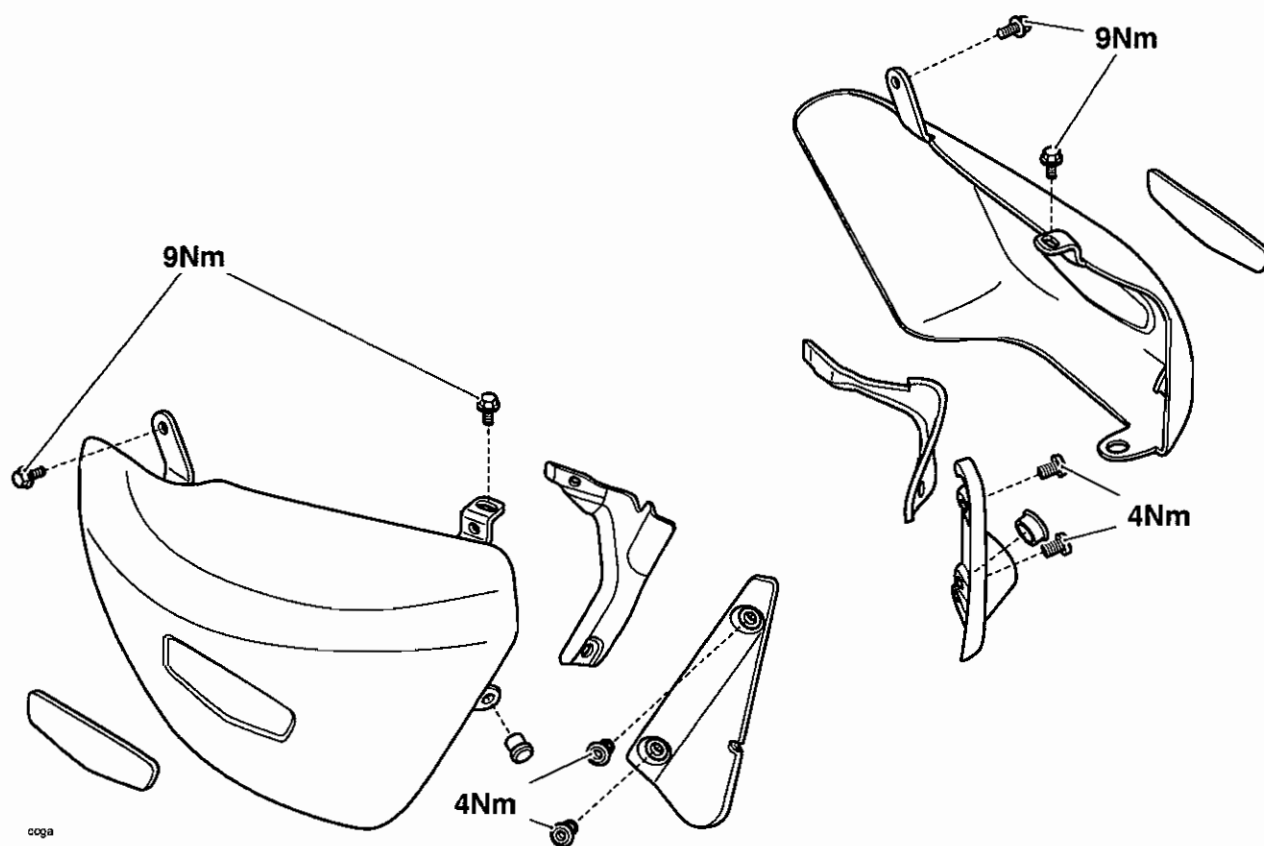

Exploded View - Side Stand

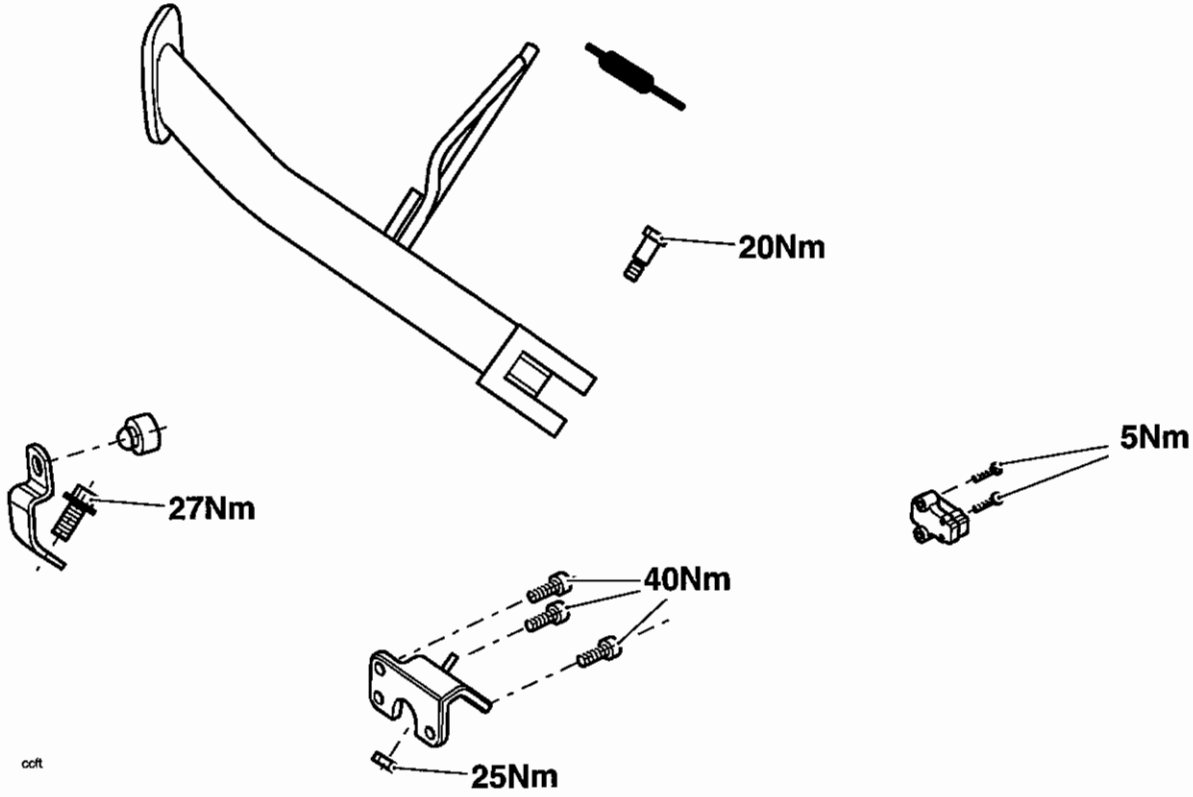

Frame and Bodywork

General Frame Inspection

1. Inspect the frame and footrests for accident and other damage, cracks, splits and general dilapidations. Check all fixings for security. If any faults are found, the frame must be replaced.

Warning

If the motorcycle is involved in an accident or collision it must be taken to an authorised Triumph dealer for inspection and repair before it is ridden again.

Warning

The frame must not be modified in any way. Any modification to the frame, such as welding or drilling, may weaken the structure causing an unsafe riding condition leading to loss of control and an accident.

2. Check the operation of the side stand to make sure it is securely held in the retracted position by the spring. Rectify any faults.

Warning

If the return spring is faulty, the side stand could extend whilst the motorcycle is being ridden. This will cause an unsafe riding condition, which could lead to loss of motorcycle control and an accident.

3. Inspect the bank angle indicators on the rider's footrests for wear. The bank angle indicators are worn out when the 5mm of the bank angle peg remains.

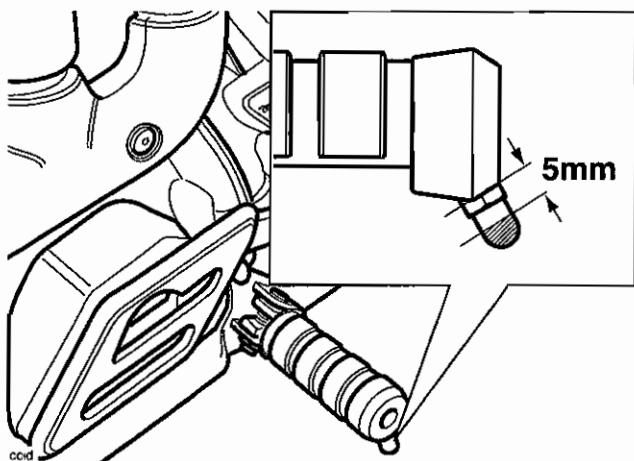

Warning

Use of a motorcycle with bank angle indicators worn beyond the maximum limit (when the bank angle indicator is worn to a minimum 5 mm in length) will allow the motorcycle to be banked to an unsafe angle. Therefore, always replace the bank angle indicator pegs when they are worn to 5 mm in length.

Banking to an unsafe angle may cause instability, loss of motorcycle control and an accident.

Warning

The bank angle pegs must not be used as a guide to how far the motorcycle may be safely banked. This depends on many various conditions including, but not limited to, road surface, tyre condition and weather. Banking to an unsafe angle will lead to loss of motorcycle control and an accident.

Seats



Before starting work, ensure the motorcycle is stabilised and adequately supported. This will help prevent it from falling and causing injury to the operator or damage to the motorcycle.

Rider's seat

The seat lock is located at the rear of the right hand side cover. To remove the rider's seat, insert the ignition key into the seat lock and turn it anti-clockwise while pressing down on the rear of the seat. This will release the seat from its lock and allow it to be slid upwards for complete removal from the motorcycle.

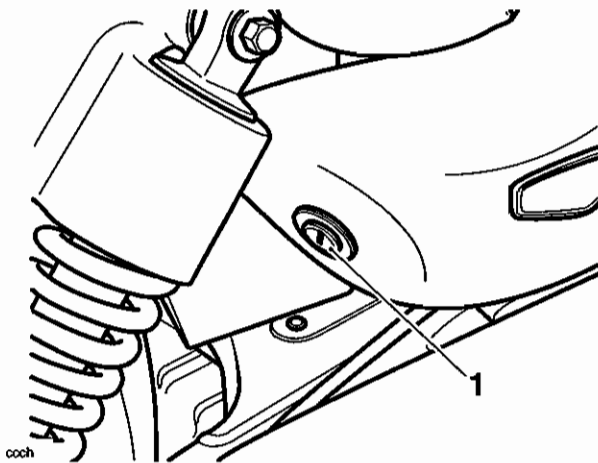

Seat lock

To refit the rider's seat, engage the seat's tongue under the fuel tank and press down at the rear to engage in the seat lock.



To prevent detachment of the seat during riding, after fitting always grasp the seat and pull firmly upwards. If the seat is not correctly secured in the lock it will detach from the rear frame. A loose or detached seat could cause loss of motorcycle control and an accident.

Rear Seat

Remove the rider's seat and release the fixings securing the rear seat to the mudguard.

To refit the rear seat, position it to the rear mudguard and tighten the three fixings to **9 Nm**. Refit the rider's seat.

Side Covers

Removal



Before starting work, ensure the motorcycle is stabilised and adequately supported. This will help prevent it from falling and causing injury to the operator or damage to the motorcycle.

1. Remove the seat as described on page 17.9.
2. Raise the tool kit.
3. Release the two screws securing each side cover to the frame.

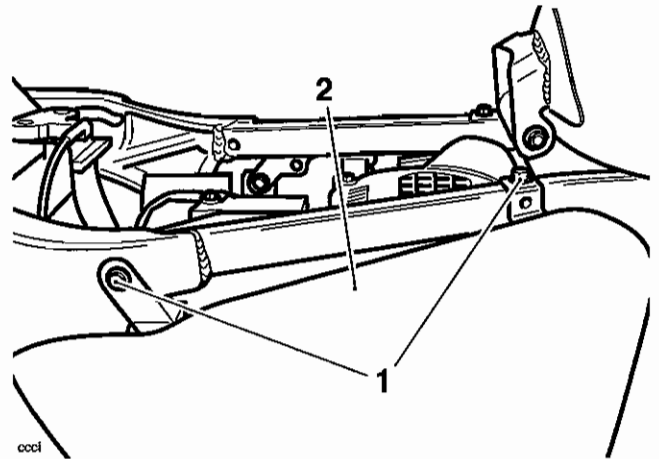

1. Screws
2. Side covers

Note:

- **During removal of the right hand side cover, disengage the seat lock from the rear of the cover.**
4. Raise each side cover until clear of the mounting posts. The covers may then be removed from the motorcycle.

Installation

1. Ensure that the mounting post grommets are correctly installed in the cover bases.
2. Install the covers to their mounting posts ensuring the grommets are not displaced. Ensure that the right hand cover engages correctly over the seat lock.
3. Fit and tighten the cover screws to **9 Nm**.
4. Pivot the tool kit into place.
5. Refit the seat as described on page 17.9.

Frame and Bodywork

Engine Infill Panels

Engine infill panels are fitted to the frame, towards the rear of the engine, on both sides of the motorcycle.

Removal

Warning

Before starting work, ensure the motorcycle is stabilised and adequately supported. This will help prevent it from falling and causing injury to the operator or damage to the motorcycle.

1. Release the two screws securing each panel to the frame.

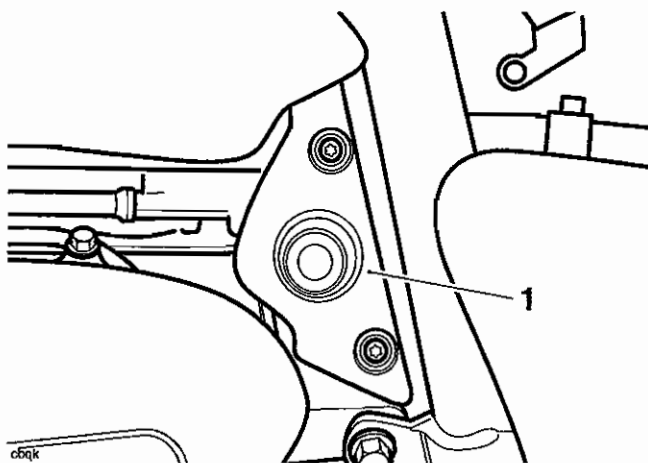

1. Infill panel

2. Withdraw the infill panel.

Note:

- A connector bracket is located behind the infill panel on the left hand side.

Installation

1. Position the left hand engine infill panel to the frame. Align the screw holes in the panel with those in the connector bracket and frame.
2. Fit the screws and tighten to **3 Nm**.
3. Repeat for the right hand panel.

Note:

- There is no connector bracket on the right hand side.

Front Mudguard

Removal

Warning

Before starting work, ensure the motorcycle is stabilised and adequately supported. This will help prevent it from falling and causing injury to the operator or damage to the motorcycle.

1. Undo the fixings securing the mudguard shrouds to the fork legs.

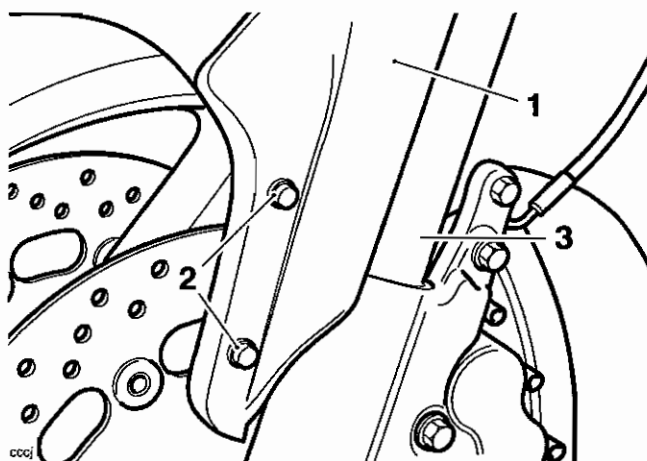

1. Mudguard shroud

2. Mudguard shroud fixings

3. Fork leg

2. Detach both shrouds.
3. Detach the brake hoses from their clips on each side of the mudguard.

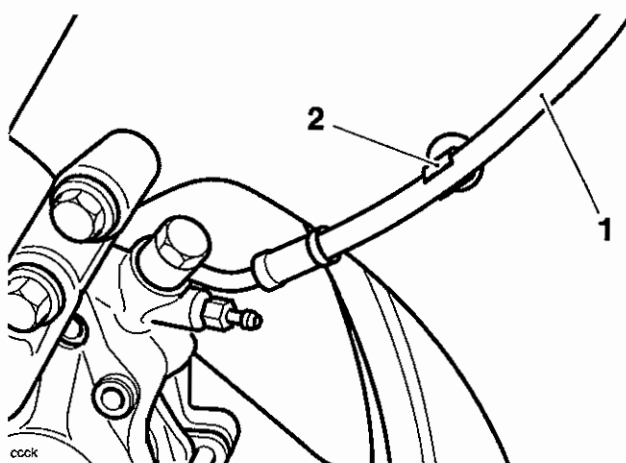

1. Brake hoses

2. Clips

4. Release the mudguard fixings and detach the mudguard.

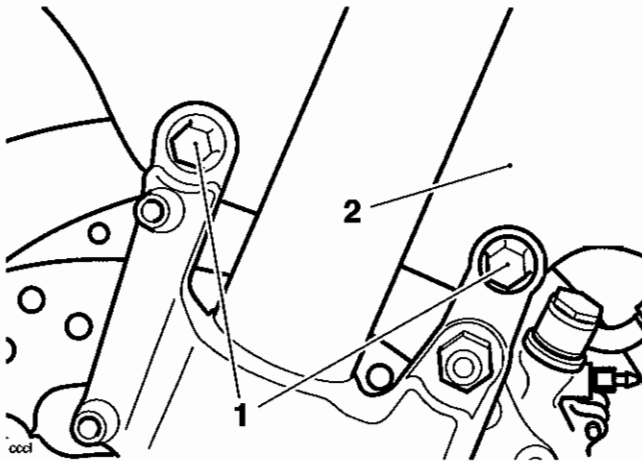

1. Mudguard Fixings
2. Mudguard

Mudguard embellisher removal

Note:

- To remove the embellisher from the mudguard, it is necessary to remove the triangular Triumph sticker. The sticker will then typically require replacement.

1. Remove the star-washers from each side of the embellisher, inside the mudguard.

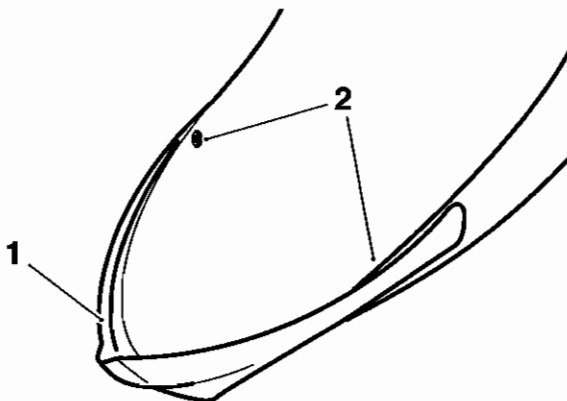

cccm

1. Embellisher
2. Star washers

2. Peel back the triangular Triumph sticker to reveal the screw head beneath it.

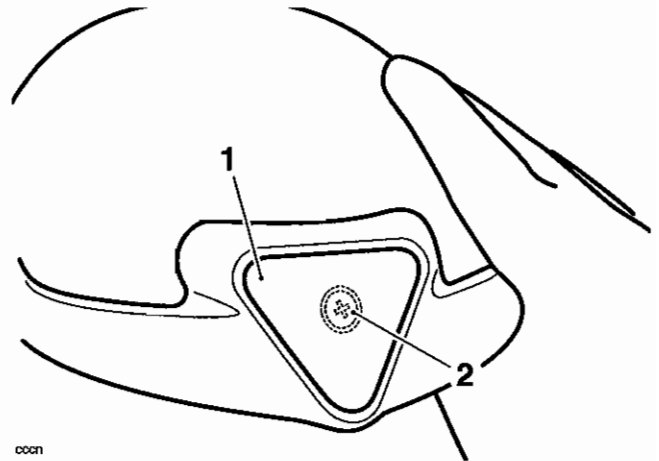

1. Sticker
2. Screw head
3. Release the screw to allow detachment of the embellisher.

Embellisher assembly

Caution

When fitting the mudguard embellisher, it is necessary to pull the two ends apart slightly, to avoid damage to the mudguard painted surfaces.

1. Position the embellisher to the mudguard, then fit and tighten the screw to **3 Nm**.
2. Working inside the mudguard, fit star washers to each side of the embellisher.
3. Thoroughly clean the area beneath the Triumph sticker.
4. Peel the backing from a new sticker then fix it to the space on the embellisher.

Installation

1. Manoeuvre the mudguard into position between the forks.
2. Fit and tighten the mudguard fixings to **27 Nm**.
3. Position the mudguard shrouds to the forks.
4. Fit and tighten the shroud fixings to **9 Nm**.
5. Refit the brake hoses to the clips on each side of the mudguard.

Frame and Bodywork

Rear Mudguard

Removal

Warning

Before starting work, ensure the motorcycle is stabilised and adequately supported. This will help prevent it from falling and causing injury to the operator or damage to the motorcycle.

1. Remove the seats as described on page 17.9.
2. Disconnect the battery, negative (black) lead first.
3. Remove both side covers as described on page 17.9.
4. Trace the wiring back from the number plate light, rear indicators and rear light assembly and disconnect their wiring connectors from the main harness. The connections will be near to the engine management ECU on the right hand side of the motorcycle.

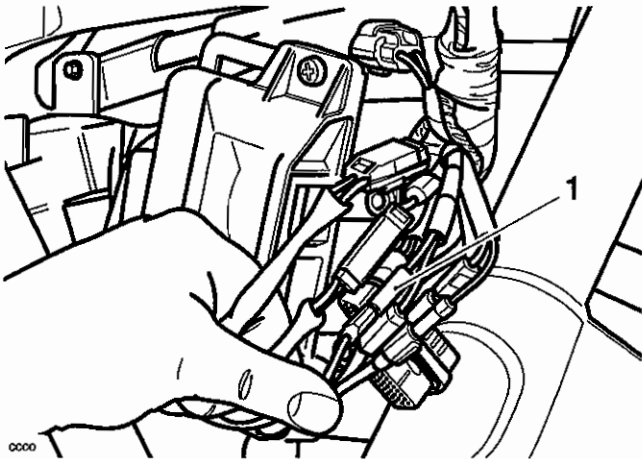

Wiring connections

Note:

- Prior to disconnection, note the relative locations of the wires to their mating connectors.

5. Release the two fixings from each side of the rear mudguard cover.

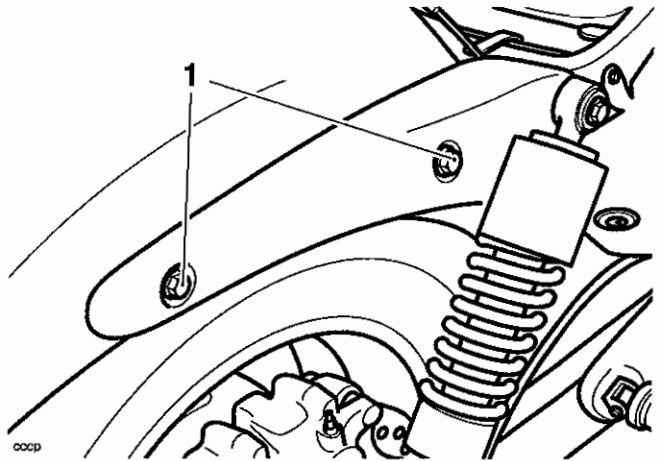

1. Rear mudguard cover fixings

Note:

- After removal, the mudguard will not detach from the frame
6. Detach the mudguard covers from the both sides. The covers locate in a grommet at their forward edge.

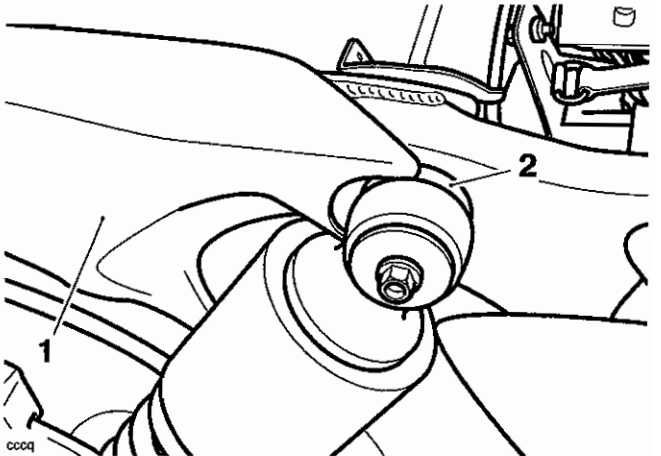

1. Mudguard cover
2. Grommet

- Support the rear mudguard then release the remaining fixings (two per side) that secure the rear mudguard to the frame.

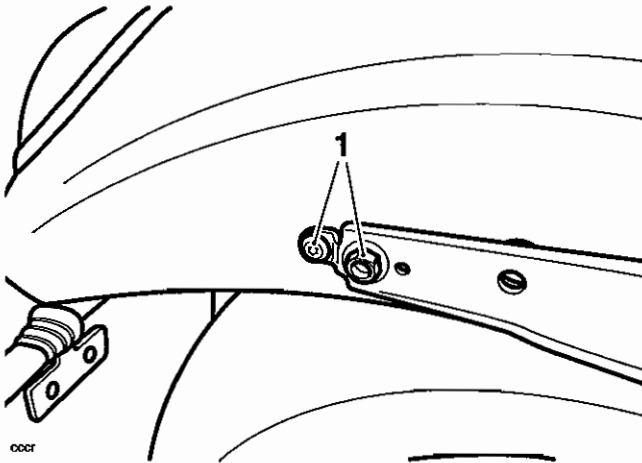

1. Mudguard fixings

- Pivot the mudguard downwards at the rear. Lift the forward locating arms from the frame cross-tube to detach the mudguard completely.

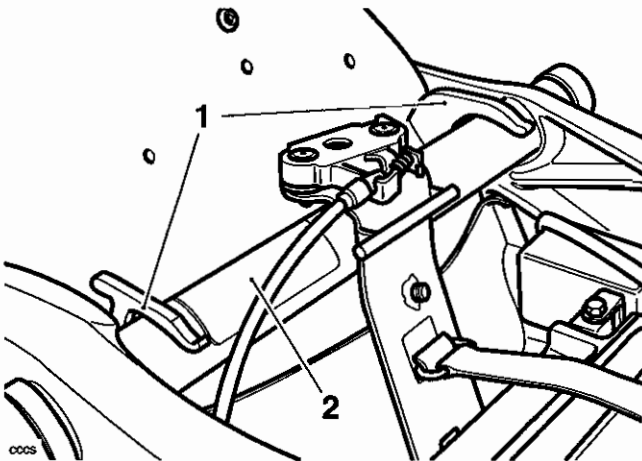

1. Locating arms
2. Frame cross tube

- Release the fixings securing the mudguard brace to the mudguard.

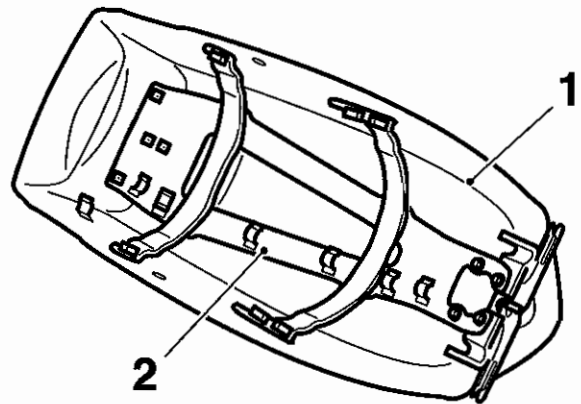

1. Mudguard
2. Mudguard brace

- Detach the brace from within the mudguard.
- The rear light, number plate light and indicators may all be removed by releasing the mounting plate, behind the rear lamp, inside the mudguard.

Installation

- Locate the mudguard brace to the inside of the mudguard.
- Fit and tighten the M6 x 12mm fixing to 5 Nm.
- If removed, refit the rear light, number plate light and indicators to the rear mudguard. Tighten the fixings to 9 Nm.

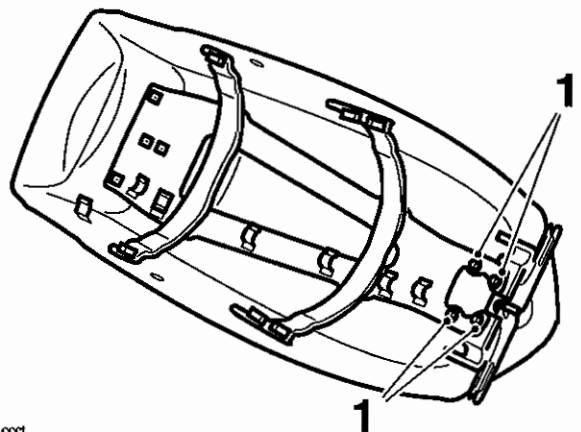

1. Rear light fixings

- Locate the mudguard to the frame, positioning the locating arms above the frame cross tube.

Frame and Bodywork

5. Pivot the mudguard upwards at the rear and engage the two M6 x 16 mm fixings through the frame and into the mudguard.

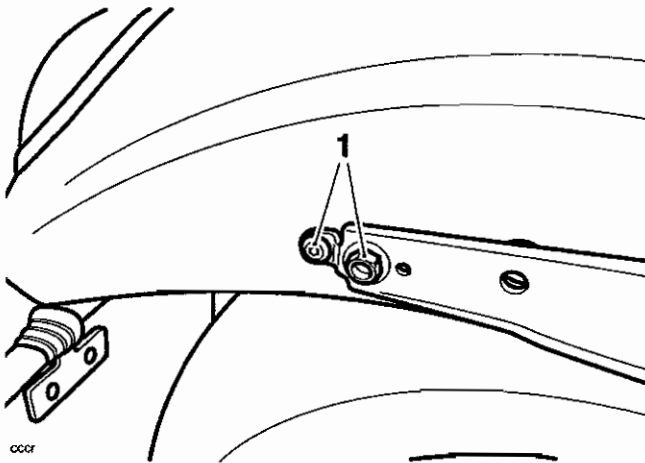

1. Fixings

6. Tighten the fixings to **14 Nm**.
7. Position the mudguard covers, engaging their forward edges to the grommets.

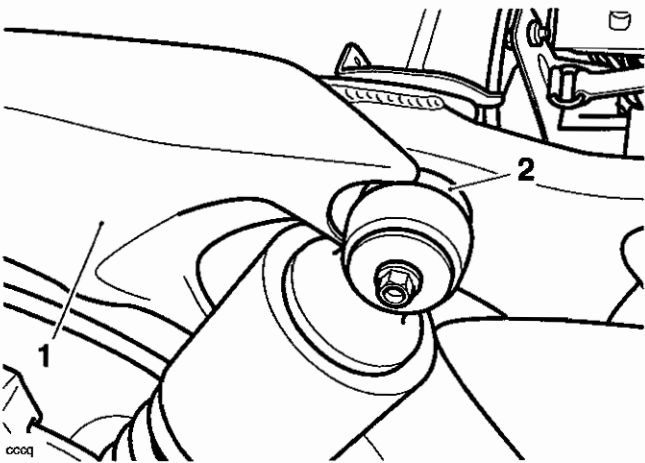

1. Cover
2. Grommet

8. Fit the mudguard cover fixings. Tighten the M8 fixings to **26 Nm** and the M10 fixings to **64 Nm**.

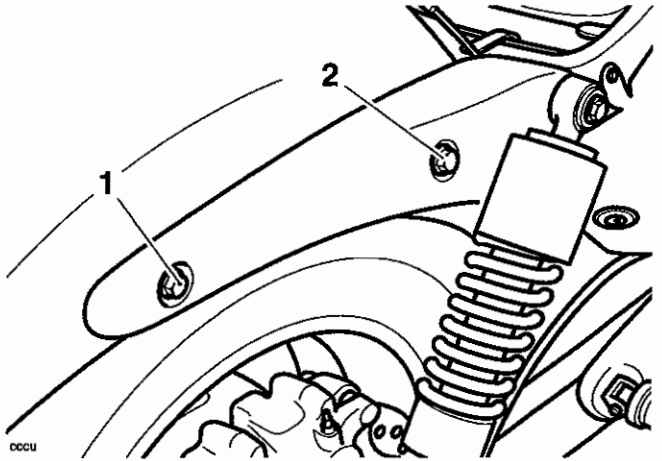

1. M8 fixing

2. M10 fixing

9. Reconnect the rear light, number plate light and indicators.
10. Reconnect the battery, positive (red) lead first.
11. Check that the rear light, number plate light and indicators all function correctly.
12. Refit the side covers as described on page 17.9.
13. Refit the seats as described on page 17.9.

Handlebars

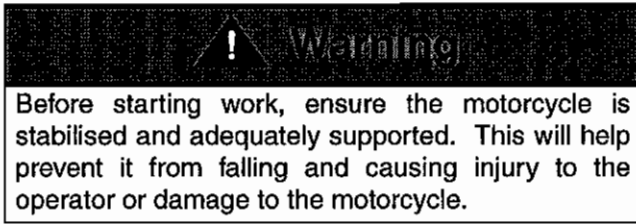

Removal

1. Undo the screws and remove the end weights from the handlebars.

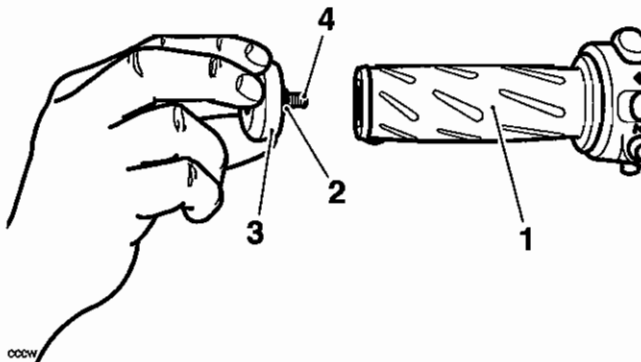

1. Handlebar
2. Spacer
3. End weight
4. Fixing

2. Release the wiring and brake hose from its clips on either side of the handlebar.
3. Undo the screws and free the left switchgear assembly from the handlebar.
4. Unscrew the bolts and remove the clamp from the clutch lever assembly.
5. Undo the screws and free the right switchgear assembly from the front brake master cylinder. Free the switch wiring from the handlebars.
6. Unscrew the bolts and remove the clamp from the master cylinder.

7. Release the two screws securing the upper cover of the handlebar clamp to the lower section.



1. Upper cover
2. Screws

8. Pivot the instruments forward to reveal the handlebar clamp bolts.

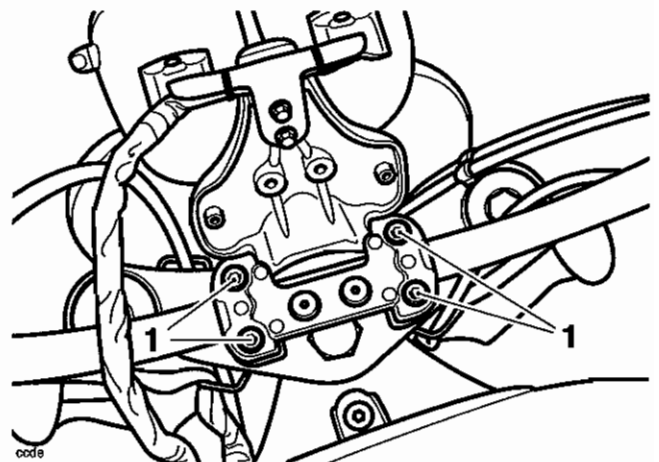

1. Handlebar clamp bolts

9. Support the handlebars then unscrew the bolts and lift off the handlebar clamp, together with the instruments. Protect the top of the fuel tank from accidental damage and then lay the instruments and clamp on the fuel tank.
10. Free the handlebar from the twist-grip/master cylinder assembly and remove it from the motorcycle. Support the master cylinder in an upright position.

Frame and Bodywork

Installation

1. Fit the throttle twist-grip assembly then locate the handlebars in the lower halves of the clamp. Fit the clamp and bolts together with the instruments.
2. Align the handlebar punch mark with the lower-rear inner left-hand split line of the clamp, then tighten the front clamp bolts to **26 Nm**, then the rears.

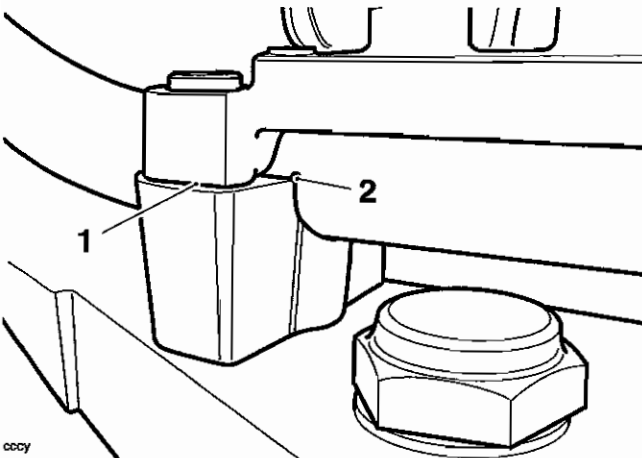

1. Clamp split line
2. Handlebar punch mark

3. Pivot the instruments into position then fit and tighten the cover bolts to **3 Nm**.
4. Locate the clutch lever assembly to the handlebar and fit the clamp.
5. Align the clamp lower split line with the punch mark on the handlebar then tighten the clamp bolts to **15 Nm**.

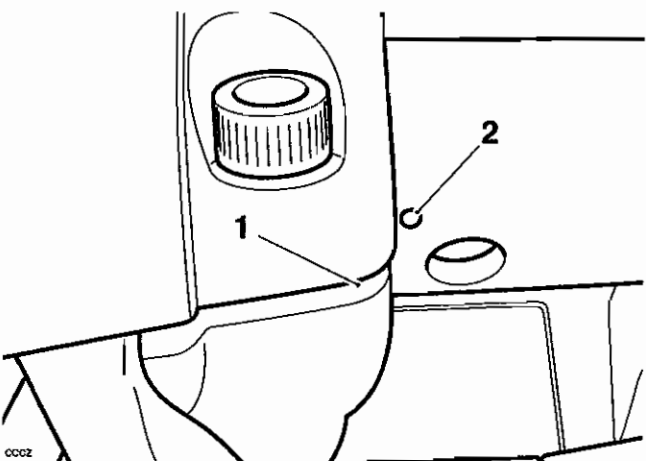

1. Clamp lower split line
2. Handlebar dot mark

6. Fit the clamp to the front brake master cylinder.

7. Align the clamp lower split line with the punch mark on the handlebar then evenly tighten the clamp bolts to **15 Nm**.

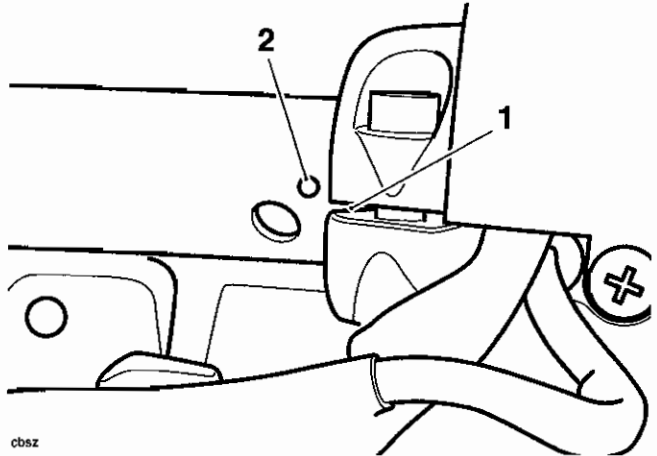

1. Clamp lower split line
2. Handlebar dot mark

8. Refit the left and right switchgear assemblies, tightening their screws to **4 Nm**.
9. Assemble the handlebar end weights into the handlebar ends, and tighten the fixings to **7 Nm**.

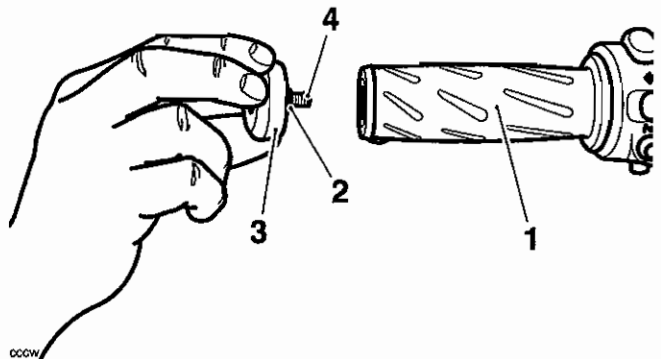

1. Handlebar
2. Spacer
3. End weight
4. Fixing

10. Renew any damaged clips before refitting all wiring and the front brake hose to the clips.
11. Check that the throttle opens and closes smoothly without sticking. Rectify as necessary.



Operation of the motorcycle with incorrectly adjusted, incorrectly routed or damaged throttle cables could interfere with the operation of the brakes, clutch or the throttle itself. Any of these conditions could result in loss of control of the motorcycle and an accident.



Move the handlebars to left and right full lock while checking that cables and harnesses do not bind or that the steering feels tight or difficult to turn. A cable or harness that binds, or is tight/difficult to turn steering will restrict the steering and may cause loss of control and an accident.

Side Stand

Removal



Before starting work, ensure the motorcycle is stabilised and adequately supported. This will help prevent it from falling and causing injury to the operator or damage to the motorcycle.

1. Raise and support the motorcycle.
2. Unhook the spring from the side stand and remove it from the motorcycle.



Wear hand, eye and face protection when unhooking the stand spring. Take great care to minimise the risk of personal injury and loss of components.

3. Unscrew the nut from the side stand pivot bolt.
4. Unscrew the pivot bolt and remove the stand from the bike.

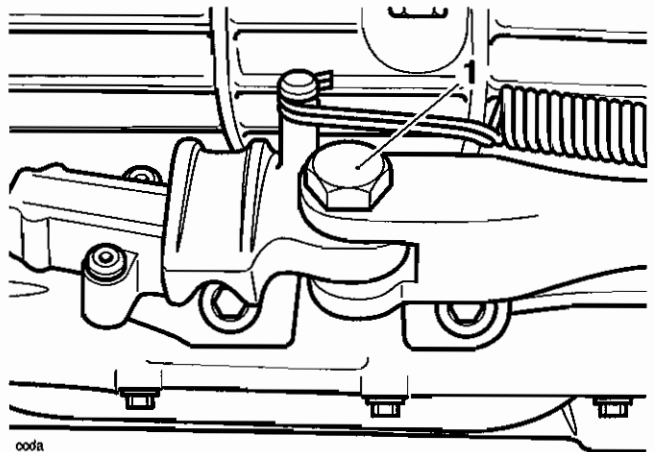

Installation

1. Lubricate the pivot bolt shoulder and side stand pivot with multi-purpose grease.
2. Fit the stand to the bike and insert the pivot bolt, tightening it **20 Nm**.
3. Fit the locknut to the pivot bolt and tighten it to **25 Nm**.
4. Hook the spring onto its frame lug then carefully hook it onto the stand lug.



Warning

Wear hand, eye and face protection when fitting the stand spring. Take great care to minimise the risk of personal injury and loss of components.

5. Check the operation of the side stand before riding the motorcycle. Ensure the spring holds the stand securely in the retracted position.

18 Electrical System

Table of Contents

| | |
|---|-------|
| Exploded View - Instruments | 18-3 |
| Exploded View - Alternator | 18-4 |
| Exploded View - Starter Motor | 18-5 |
| Exploded View - Headlight | 18-6 |
| Exploded View - Rear Light and Indicators | 18-7 |
| Exploded View - Battery, Horn and Wiring | 18-8 |
| Battery | 18-9 |
| Battery Disposal | 18-9 |
| Battery Removal | 18-9 |
| Battery Installation | 18-10 |
| New Battery Commissioning | 18-10 |
| Charging - Battery Already in Service | 18-11 |
| Battery Maintenance | 18-11 |
| Fuses | 18-11 |
| Fuse Identification | 18-12 |
| Headlights | 18-12 |
| Headlight Vertical Adjustment | 18-12 |
| Headlight Horizontal Adjustment | 18-13 |
| Headlight Bulb Replacement | 18-13 |
| Rear Light | 18-14 |
| Bulb Replacement | 18-14 |
| Indicator Lights | 18-14 |
| Bulb Replacement | 18-14 |
| Alternator | 18-15 |
| Removal | 18-15 |
| Inspection | 18-16 |
| Assembly | 18-16 |
| Alternator Rectifier | 18-17 |
| Removal | 18-17 |
| Installation | 18-17 |
| Starter Motor | 18-18 |
| Removal | 18-18 |
| Installation | 18-18 |

Electrical System

| | |
|---|-------|
| Relays | 18-19 |
| Identification and location | 18-19 |
| Relay identification – left hand side | 18-19 |
| Relay identification – right hand side | 18-19 |
| ECM Connector Pin Numbering | 18-19 |
| Lighting Circuit | 18-20 |
| Circuit Diagram - Lighting | 18-21 |
| Starting and Charging Circuit | 18-22 |
| Circuit Diagram - Starting and Charging | 18-23 |
| Auxiliary and Accessory Circuit | 18-24 |
| Circuit Diagram - Auxiliary and Accessory | 18-25 |
| Complete System | 18-26 |
| Key to Circuit Diagram | 18-26 |

Exploded View - Instruments

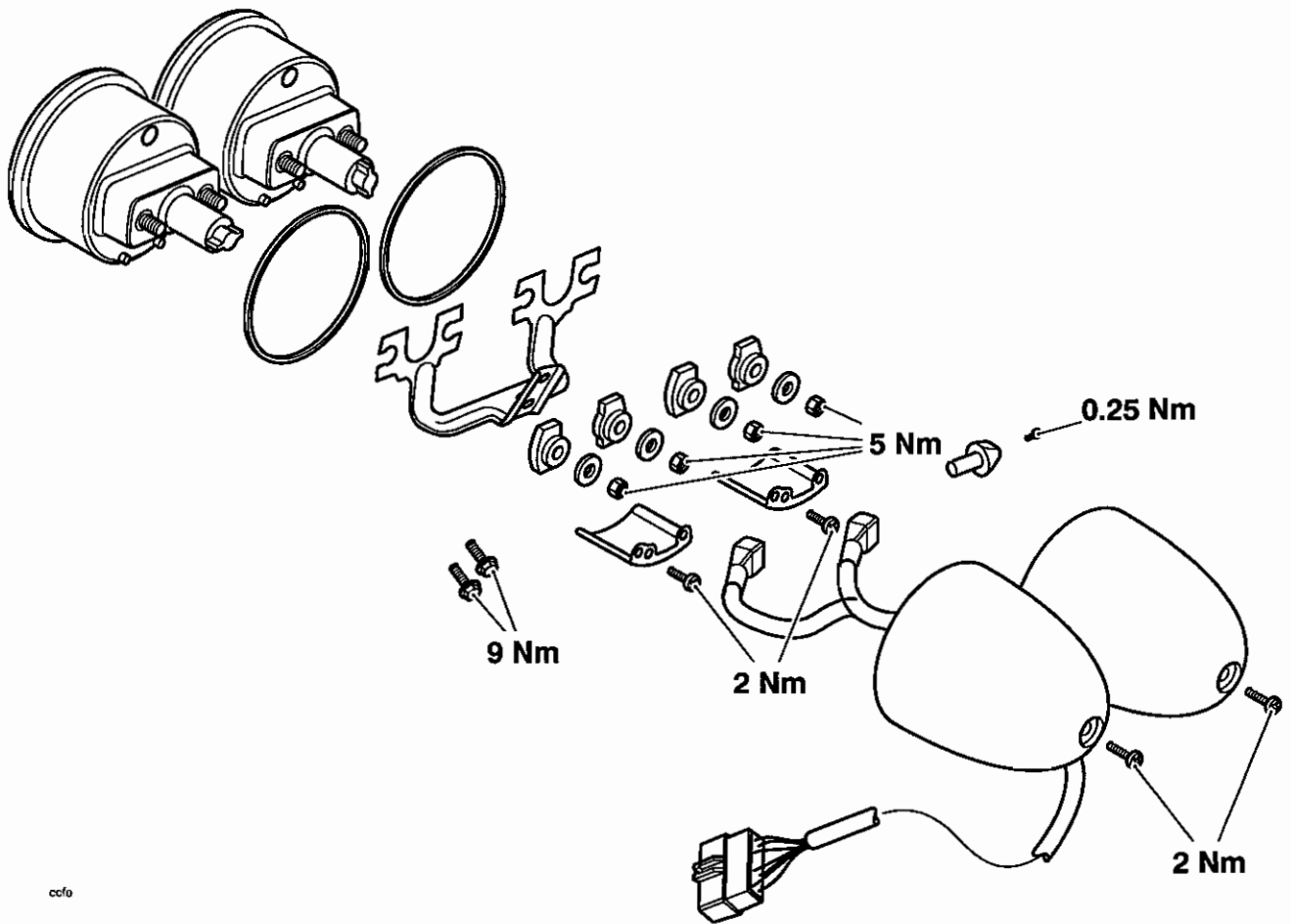

ccfo

Electrical System

Exploded View - Alternator

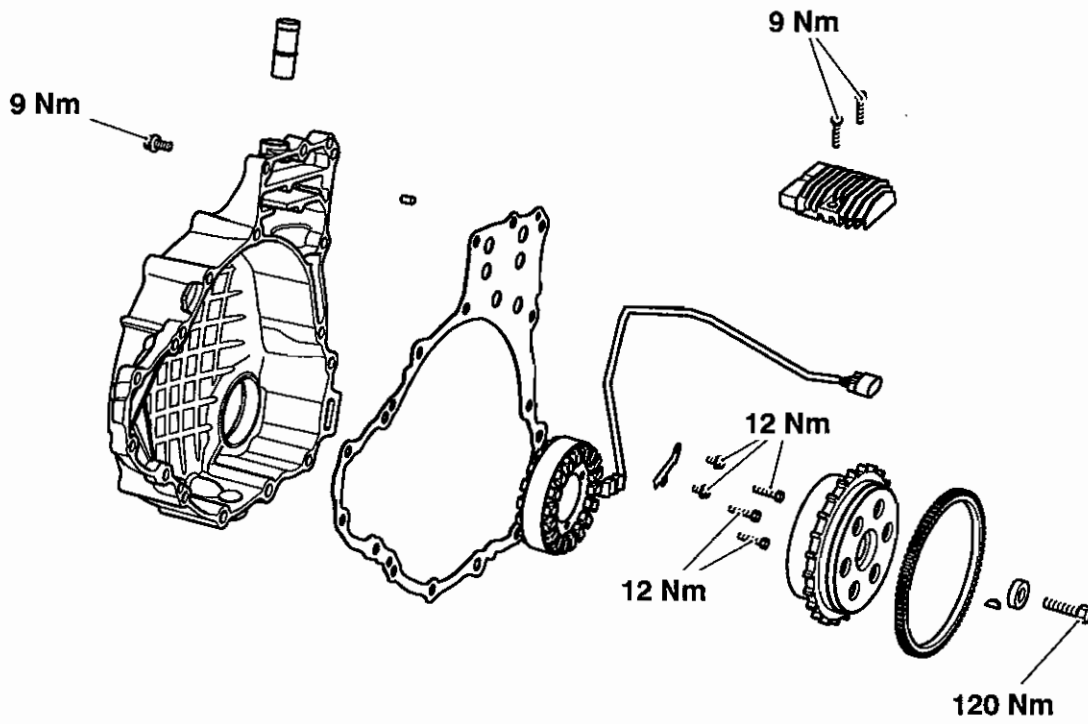

Exploded View - Starter Motor

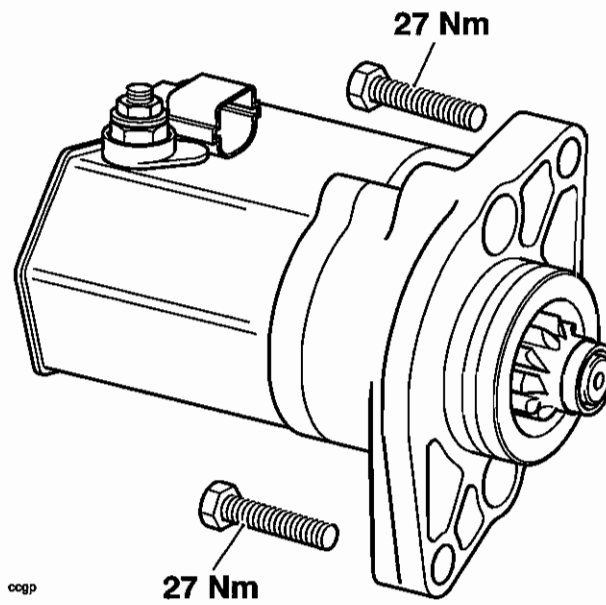

Electrical System

Exploded View - Headlight

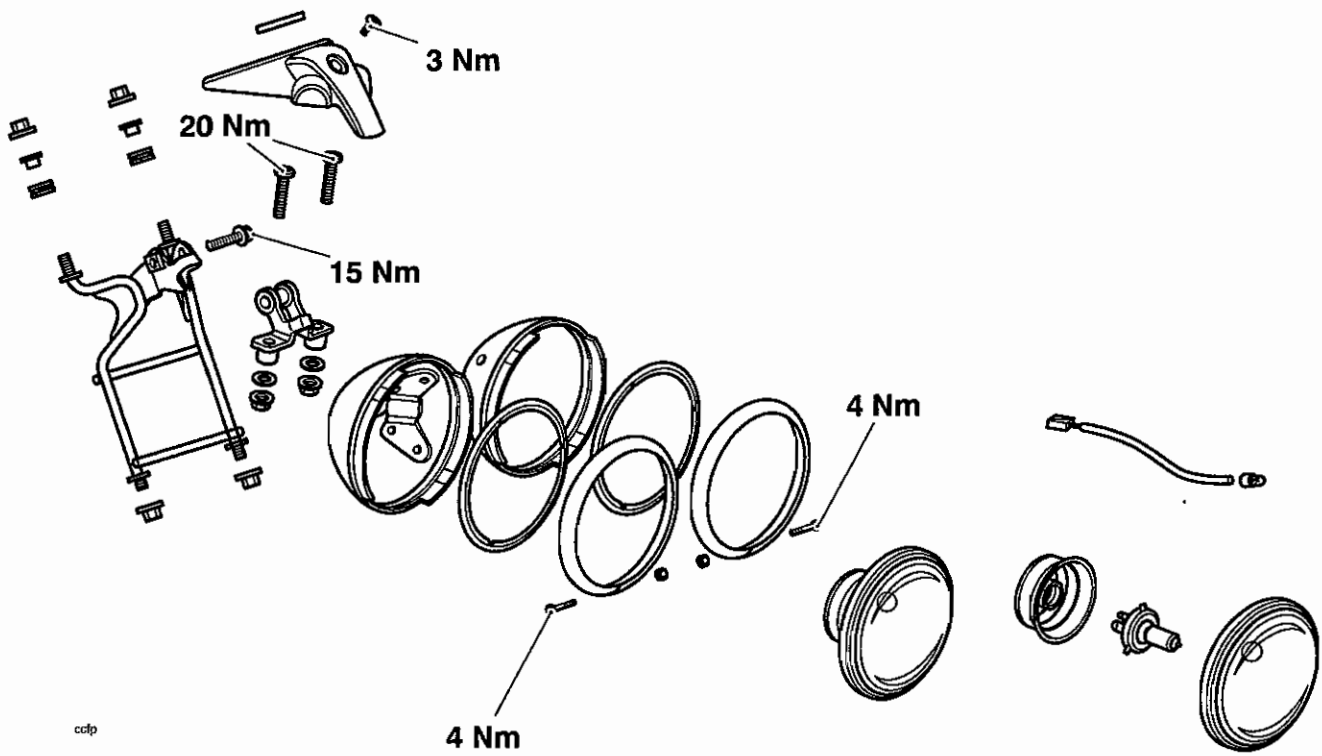

Exploded View - Rear Light and Indicators

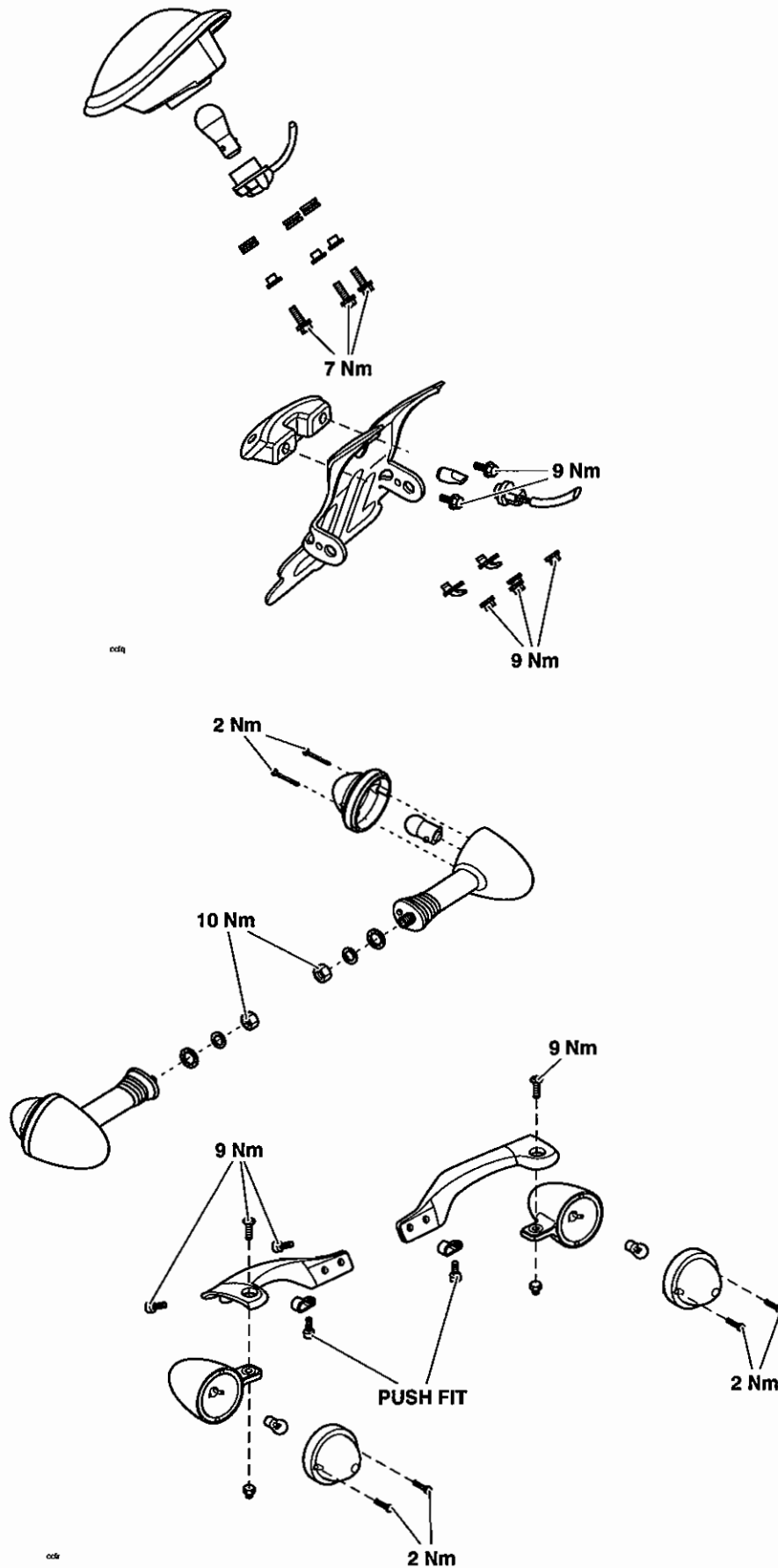

Electrical System

Exploded View - Battery, Horn and Wiring

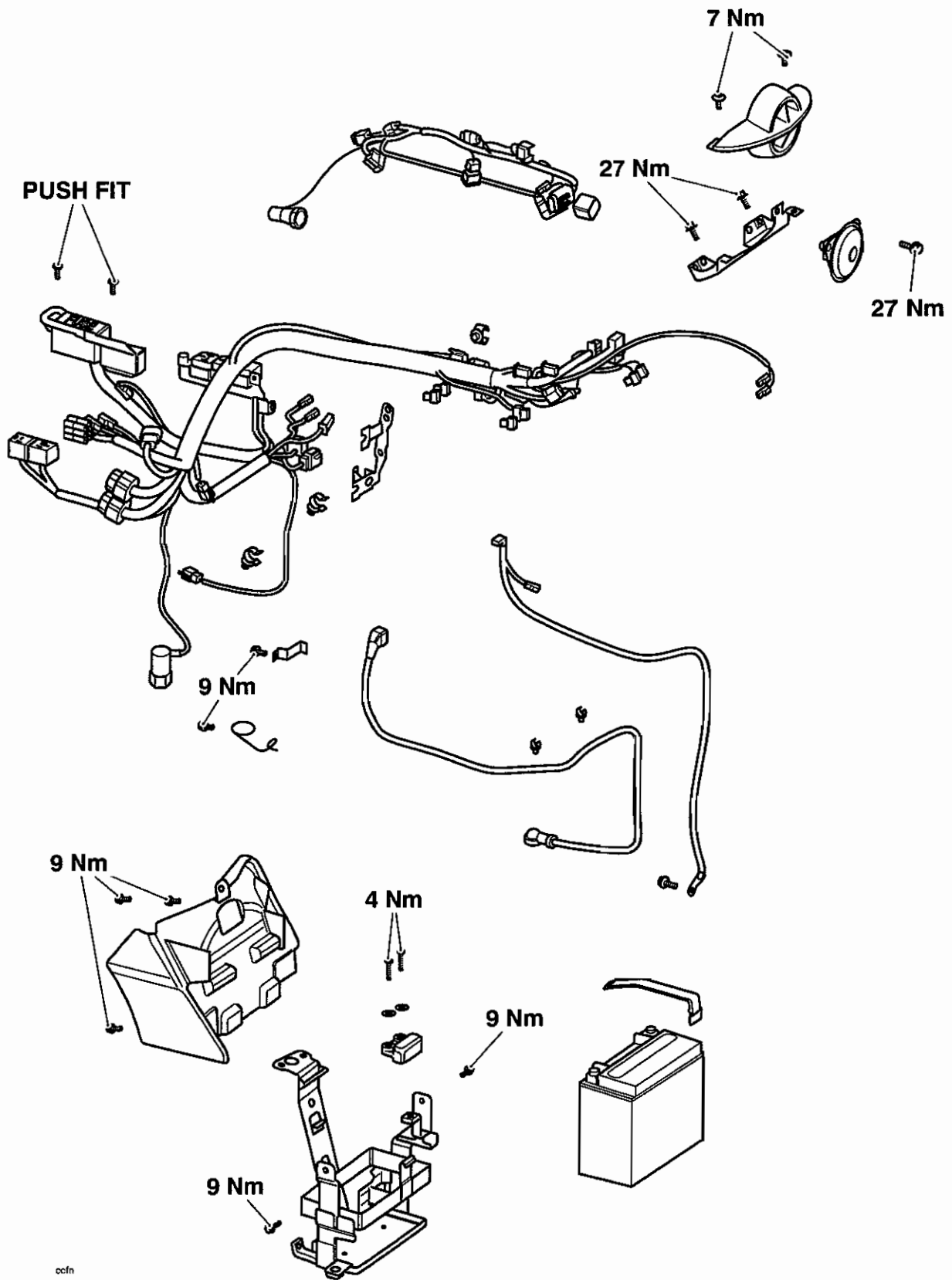

Battery



Under some circumstances, the battery can give off explosive gases; keep sparks, flames and cigarettes away. Provide adequate ventilation when charging or using the battery in an enclosed space.

The battery contains sulphuric acid (electrolyte). Contact with skin or eyes may cause severe burns. Wear protective clothing and a face shield.

If electrolyte gets on your skin, flush with water immediately.

If electrolyte gets in your eyes, flush with water for at least 15 minutes and SEEK MEDICAL ATTENTION IMMEDIATELY.

If electrolyte is swallowed, drink large quantities of water and SEEK MEDICAL ATTENTION IMMEDIATELY.

KEEP ELECTROLYTE OUT OF THE REACH OF CHILDREN.



The battery contains harmful materials. Always keep children away from the battery whether or not it is fitted in the motorcycle.

Do not attach jump leads to the battery, touch the battery cables together or reverse the polarity of the cables as any of these actions may cause a spark which would ignite battery gases causing a risk of personal injury.

Battery Disposal

Should the battery ever require replacement, the original battery must be handed to a recycling agent who will ensure that the dangerous substances from which the battery is manufactured do not pollute the environment.

Battery Removal

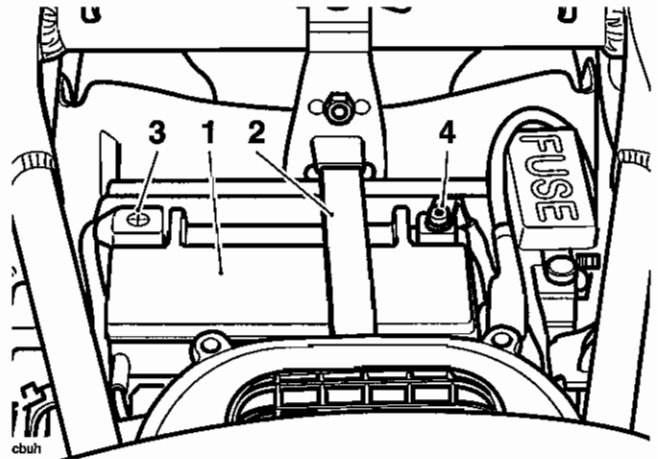

1. Battery
2. Battery strap
3. Positive (red) terminal
4. Negative terminal

1. Remove the rider's seat.
2. Lift up the tool box at its front edge and pivot it towards the rear of the motorcycle.
3. Remove the battery strap.
4. Disconnect the battery leads, negative (black) lead first.
5. Take the battery out of the case.



Ensure that the battery terminals do not touch the motorcycle frame as this may cause a short circuit or spark, which would ignite battery gases causing a risk of personal injury.

Battery Installation

Warning

Ensure that the battery terminals do not touch the motorcycle frame as this may cause a short circuit or spark, which would ignite battery gases causing a risk of personal injury.

1. Place the battery in the battery case.
2. Reconnect the battery, positive (red) lead first.
3. Apply a light coat of grease to the terminals to prevent corrosion.
4. Cover the positive terminal with the protective cap.
5. Refit the battery strap.
6. Lower the tool kit tray into place.
7. Refit the rider's seat as described on page 17.9.

New Battery Commissioning

Warning

The battery electrolyte is corrosive and poisonous. Never swallow battery electrolyte or allow it to come into contact with the skin. To help reduce the risk of injury, always wear eye and skin protection when filling and sealing the battery.

To ensure that a new battery is correctly commissioned and will deliver maximum capacity for starting, the following procedure must be followed.

1. Read the instructions and warnings delivered with the battery!
2. Place the battery on a flat level surface and remove the sealing foil.
3. Remove the battery sealing strip from the electrolyte container (if fitted) and save for use later in this procedure. Do not break the seal on the electrolyte container.
4. Place the electrolyte container and adapter (if supplied) on the battery and fill the battery according to the manufacturers instructions.
5. After starting to fill the battery with electrolyte, allow the battery to stand for 30 minutes with the filling container in place.
6. Check that all of the electrolyte has drained from the container, do not remove container at this point. If the container has not completely drained, gently tap the sides of the container to start the electrolyte flowing again.
7. After all of the electrolyte has drained into the battery, allow the battery to stand, with the electrolyte container in place, for a further 30 minutes for batteries 3Ah - 12Ah or 1 hour for batteries greater than 12Ah.
8. Remove the electrolyte container and adapter carefully, and dispose of both immediately.
9. Fit the sealing caps to the battery according to the battery manufacturers instructions.
10. Measure the terminal voltage on the battery to assess the battery condition.
11. Charge the battery as necessary (see table of charging time) using a suitable charger (i.e. a charger with a suitably controlled charging current and appropriate cut off voltage.)

| Terminal Voltage Measured | Charge Time (hours) | Charge Cutoff Voltage |
|---------------------------|---------------------|-----------------------|
| 12.8 | 2 | 14.5 |
| 12.7 | 3 | 14.5 |
| 12.6 | 4 | 14.5 |
| 12.5 | 5 | 14.5 |
| Less than 12.5 | 8-10 | 14.5 |

12. Charging current should be controlled to 10% of the nominal capacity (i.e. for a 10AH battery charging current $I = 0.1 \times 10 = 1A$).
13. Disconnect the charger and allow the battery to stand for 1 hour before fitting to the motorcycle.
14. Fit the battery to the motorcycle, positive (Red) lead first.

Charging - Battery Already in Service

When re-charging a battery in service, the following precautions must be taken to avoid damage to the battery.

1. The charging rate must not exceed 1.2 A except for a boost charge where a maximum charge rate of 5 Amps. (for no longer than 1 hour) is allowed.

Caution

Boost charge should only be performed if the battery is in a severely discharged state. Boost charging a part discharged battery will damage the cells and plates leading to permanent battery damage.

Battery Maintenance

Clean the battery using a clean, dry, cloth. Be sure that the cable connections are clean.

Warning

The battery electrolyte is corrosive and poisonous and will cause damage to unprotected skin. Never swallow battery electrolyte or allow it to come into contact with the skin. To prevent injury, always wear eye and skin protection when handling the battery.

The battery is a sealed type and will not require any maintenance other than routine recharging, such as during storage.

It is not possible to adjust the electrolyte level in the battery.

Fuses

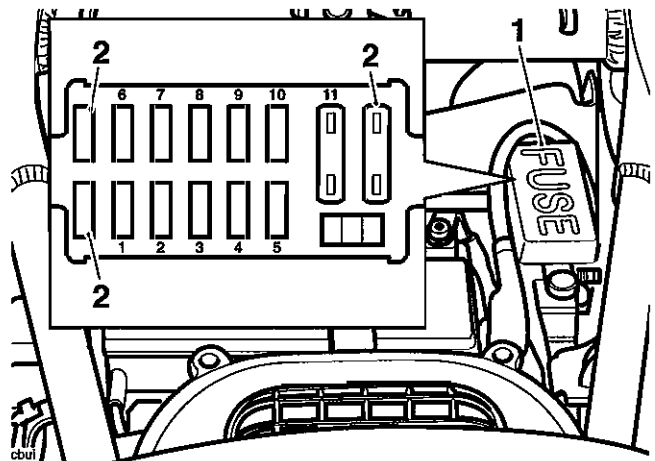

1. Fuse box
2. Spare fuses

Note:

- Numbers shown in the diagram correspond to the fuse position numbers in the table below.

The fuse box is located beneath the rider's seat.

To allow access to the fuse box, the rider's seat must be removed as described on page 17.9.

Warning

Always replace blown fuses with new ones of the correct rating (as specified on the fuse box cover) and never use a fuse of higher rating. Use of an incorrect fuse could lead to an electrical problem, resulting in motorcycle damage, loss of motorcycle control and an accident.

Electrical System

Fuse Identification

A blown fuse is indicated when all of the systems protected by that fuse become inoperative. When checking for a blown fuse, use the table below to establish which fuse has blown.

| Circuit Protected | Rating (Amps) | Position |
|--|---------------|----------|
| Accessory lights | 15 | 1 |
| Ignition switch main feed | 30 | 2 |
| Accessory socket, instrument memory, heated grips, clock | 10 | 3 |
| Alarm, diagnostic connector, indicators, brake lights | 15 | 4 |
| Instruments, fuel pump relay, starter relay, main power relay, fall detection switch | 10 | 5 |
| Engine management system | 20 | 6 |
| Cooling fan | 15 | 7 |
| Instrument illumination, position lights | 5 | 8 |
| Upper and lower headlight beams, starter solenoid | 20 | 9 |
| Position lights | 5 | 10 |
| Main fuse | 30 | 11 |

Headlights

Warning

Adjust road speed to suit the visibility and weather conditions in which the motorcycle is being operated.

Ensure that the beams are adjusted to illuminate the road surface sufficiently far ahead without dazzling oncoming traffic. An incorrectly adjusted headlight may impair visibility causing an accident.

Warning

Never attempt to adjust a headlamp beam when the motorcycle is in motion.

Any attempt to adjust a headlamp beam when the motorcycle is in motion may result in loss of control and an accident.

Note:

- The vertical beams of the left and right hand headlights can only be adjusted together. Independent adjustment is not possible.

Headlight Vertical Adjustment

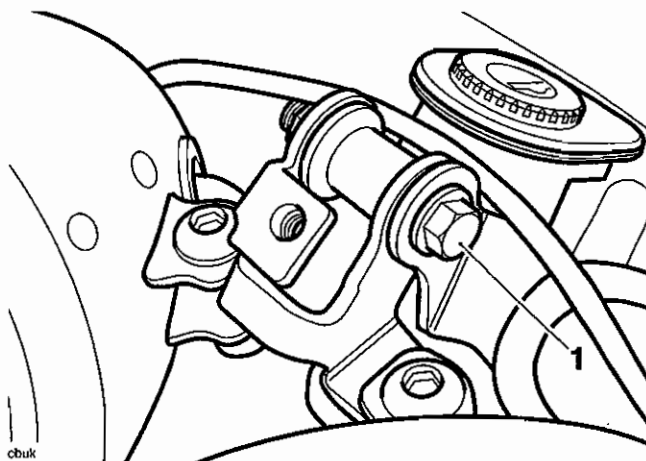

1. Vertical beam adjuster

1. Turn the ignition switch to the ON position.
2. Remove the ignition switch cover.
3. Slacken the clamp bolt sufficient to allow restricted movement of the headlights.
4. Adjust the position of the headlights to give the required beam setting.
5. Tighten the clamp bolt to **15 Nm**.
6. Re-check the headlight beam settings.
7. Refit the ignition switch cover.
8. Turn the ignition off when both beam settings are satisfactorily set.

Headlight Horizontal Adjustment

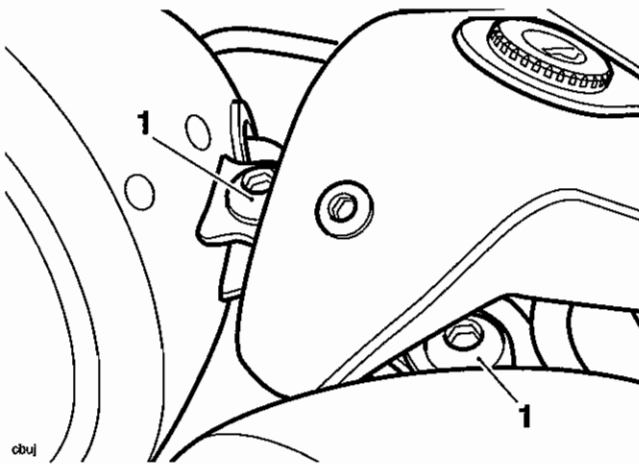

1. Horizontal beam adjuster

1. The horizontal beams of both headlights can be adjusted individually. The same procedure is used to adjust either headlight.
2. Turn the ignition switch to the ON position.
3. Slacken the headlight bowl fixing.
4. Adjust the horizontal position of the headlight to give the required beam setting.
5. Tighten the fixing to **15 Nm**.
6. Repeat for the second headlight.
7. Re-check the headlight beam settings.
8. Switch the ignition off when both beams are satisfactorily set.

Headlight Bulb Replacement

It is necessary to remove the headlight from the headlight bowl to gain access to the bulbs.

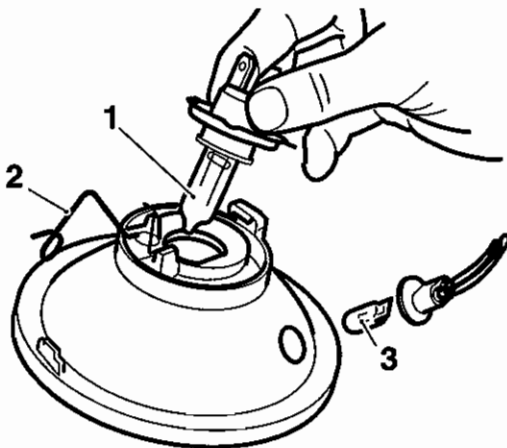

cbul

1. Headlight bulb
2. Bulb clip
3. Position light bulb

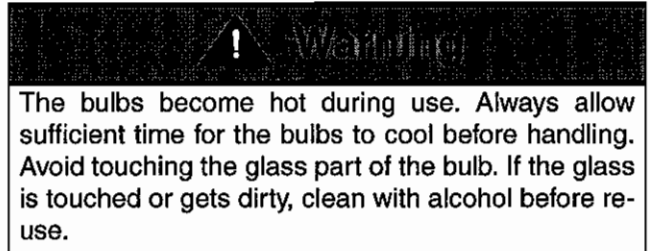

1. Remove the rider's seat.
2. Disconnect the battery, negative (black) lead first.
3. Undo the fixing securing the headlight clamp to the headlight body.
4. Support the headlight while removing the clamp.
5. Remove the headlight from its bowl while supporting it to prevent the cables from being over extended.
6. Disconnect the multi-pin electrical connector from the headlight bulb and remove the rubber cover.
7. Detach the wire retainer from its clip (do not remove the screw) then remove the bulb from the light unit.
8. To remove the position light bulb:
9. Without pulling on the wires, ease the bulb holder from its socket. The bulb is removed from its holder by pulling gently outwards.
10. Installation for both bulbs is the reverse of the removal procedure. Tighten the headlight clamp to **4 Nm**.

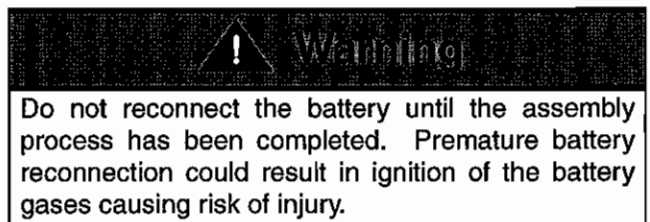
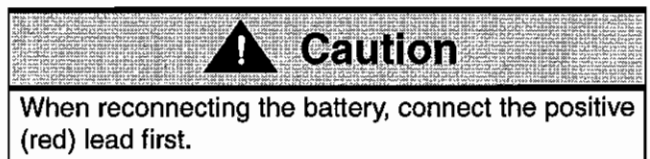

Electrical System

Rear Light

Bulb Replacement

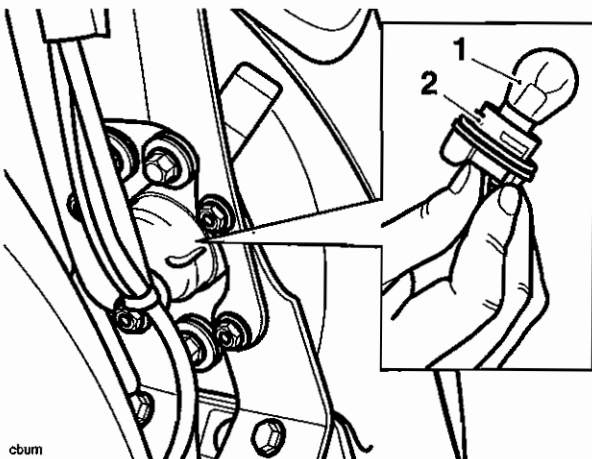

1. Rear light bulb
2. Bulb holder

Warning

The bulb becomes hot during use. Always allow sufficient time for the bulb to cool before handling. Avoid touching the glass part of the bulb. If the glass is touched or gets dirty, clean with alcohol before re-use.

1. Remove the rider's seat.
2. Disconnect the battery, negative (black) lead first.
3. The rear light bulb holder is accessed underneath the rear mudguard.
4. Rotate the bulb holder anti-clockwise to release.
5. To remove the bulb from the holder, gently pull on the bulb until it is released.
6. Installation for the bulb is the reverse of the removal procedure.

Caution

When reconnecting the battery, connect the positive (red) lead first.

Indicator Lights

Bulb Replacement

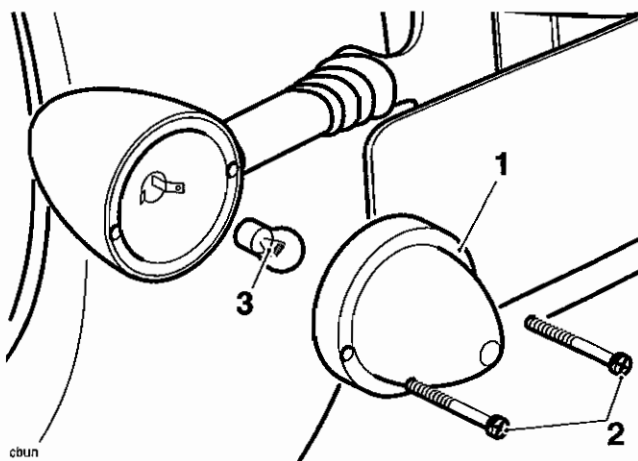

1. Lens
2. Lens screw
3. Bulb

Note:

- The lens on each indicator light is held in place by two screws.
1. Release the screws and remove the lens to gain access to the bulb for replacement.

Warning

The bulb becomes hot during use. Always allow sufficient time for the bulb to cool before handling. Avoid touching the glass part of the bulb. If the glass is touched or gets dirty, clean with alcohol before re-use.

Alternator

Removal

1. Remove the rider's seat.
2. Disconnect the battery, negative (black) lead first.
3. Remove the engine as described on page 10.2.
4. Release the bolts securing the starter motor to the alternator cover.

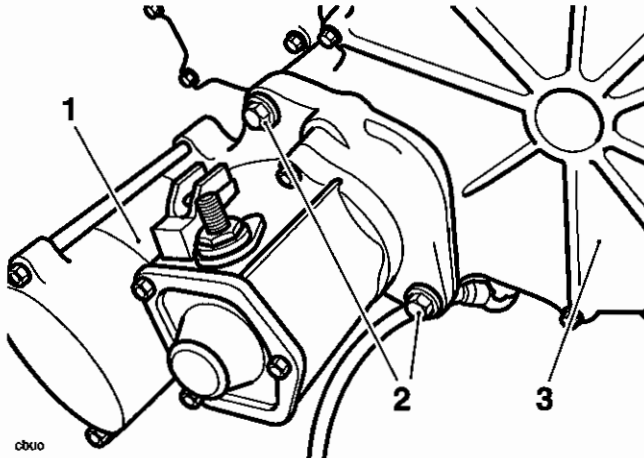

1. Starter motor
2. Starter motor fixings
3. Alternator cover

5. Release the bolts securing the alternator cover to the rear of the engine.
6. Withdraw the alternator cover from the crankcase.

Note:

- To use tool T3880201, insert the tool pegs into a pair of rotor holes. However, tool T3880201 will not engage with every pair of holes in the rotor. The holes are offset and so the tool will only engage with certain pairs of holes.

7. To remove the rotor, prevent the crankshaft from rotating using tool T3880201, and remove the centre bolt and washer from the end of the crankshaft.

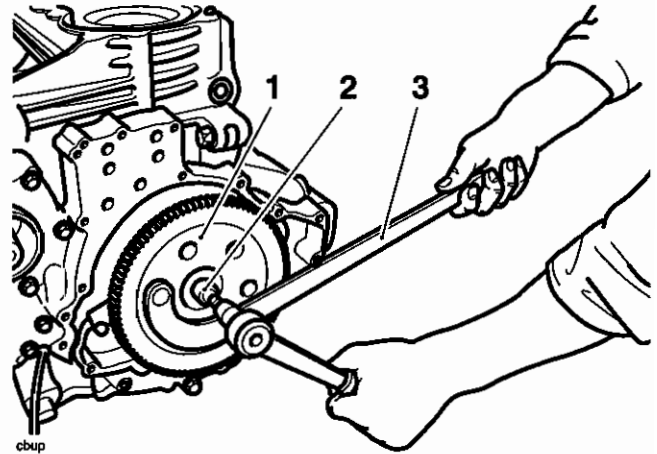

1. Rotor
2. Rotor bolt
3. Tool T3880201

8. Screw tool T3880200 into the rotor centre.
9. Prevent the rotor from turning using tool T3880201 while tightening tool T3880200. This will release the taper seating of the rotor to the crankshaft.

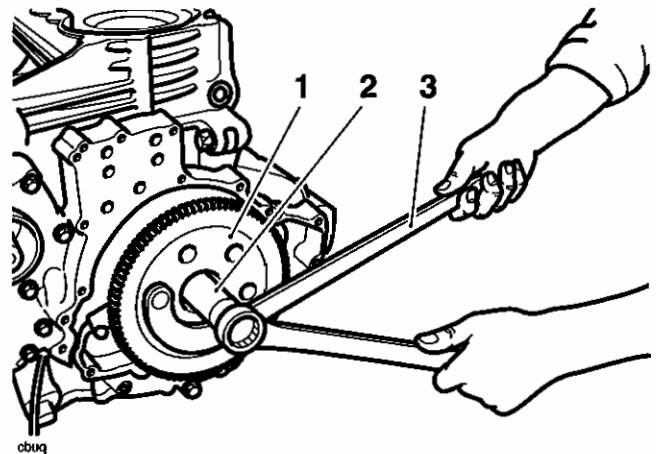

1. Rotor
2. Tool T3880200
3. Tool T3880201

10. Withdraw the rotor and tool as an assembly and then separate the tool from the rotor.

Note:

- If removing the stator, make a note of the cable routing before removing the cable retainer.

Electrical System

11. To remove the stator, release the two bolts securing the cable retainer to the crankcase.

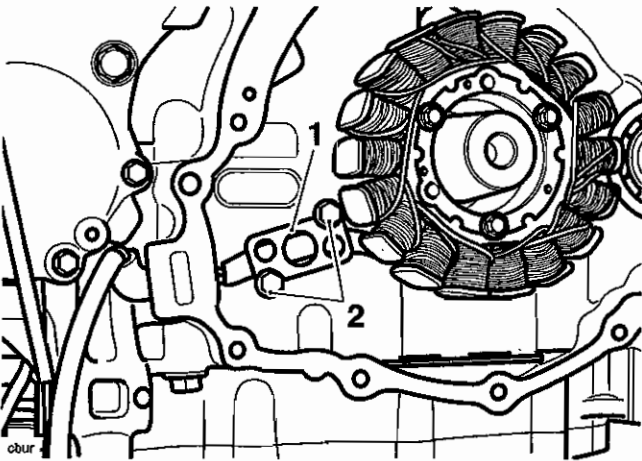

1. Cable retainer
2. Bolts

12. Release the three bolts securing the stator to the crankcase.

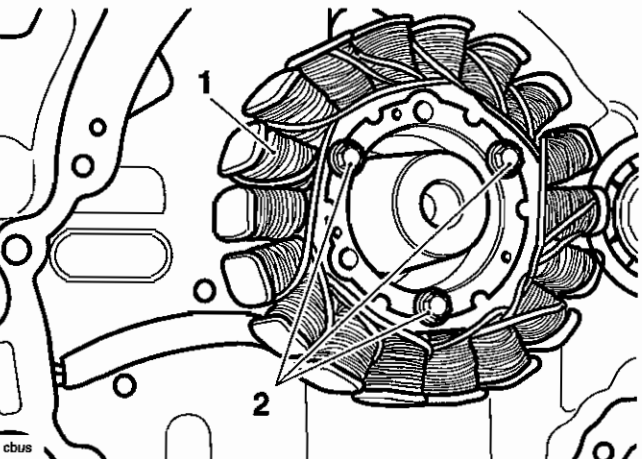

1. Stator
2. Stator bolts

13. Withdraw the stator from the crankcase.

Inspection

1. Inspect the key in the crankshaft for damage and distortion. Replace the key if necessary.
2. Inspect the rotor for damage and high spots to the taper centre. Replace the rotor if necessary.
3. Inspect the stator for signs of overheating and short/open circuits. Replace as necessary.

Assembly

1. Locate the stator to the crankcase.
2. Apply silicone sealer to the cable grommet and align the cable to the crankcase exit slot.
3. Fit the cable retainer bracket, routing the cables as noted on strip down. Tighten the retainer bolts to 12 Nm.

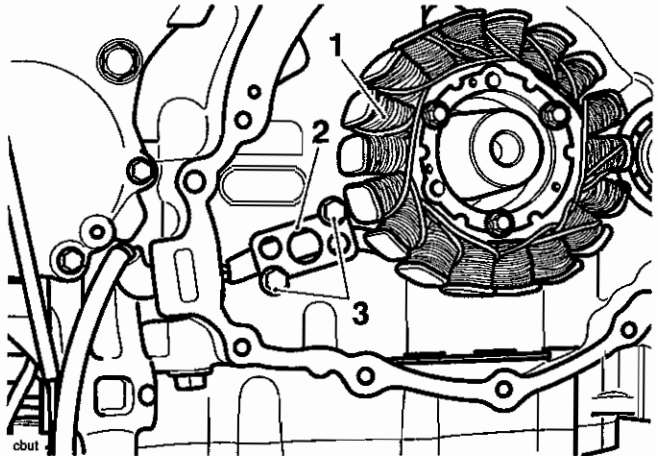

1. Stator
2. Cable retainer bracket
3. Fixings

4. Tighten the stator bolts to 12 Nm.
5. Assemble the rotor to the keyway on the crankshaft.
6. Fit the bolt and washer to the threaded hole in the crankshaft.
7. Refit tool T3880201 to prevent the crankshaft from rotating.
8. Tighten the rotor bolt to 120 Nm.

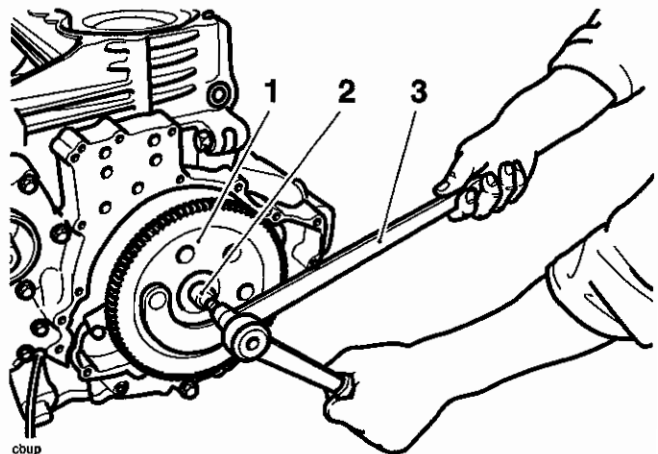

1. Rotor
2. Rotor bolt
3. Tool T3880201

9. Remove tool T3880201.
10. Incorporating a new gasket, refit the alternator cover to the rear of the engine.
11. Tighten the alternator cover bolts to **9 Nm**.
12. Incorporating a new O-ring seal, fit the starter motor and tighten the starter fixings to **27 Nm**.
13. Refit the engine as described on page 10.5.
14. Reconnect the battery positive (red) lead first.
15. Refit the rider's seat.

Alternator Rectifier

Note:

- **The alternator rectifier is attached to the battery box. The rectifier does not contain any serviceable parts and must be replaced if faulty.**

Removal

1. Remove the rider's seat as described on page 17.9.
2. Disconnect the battery, negative (black) lead first.
3. Remove the left hand side cover as described on page 17.9.
4. Disconnect both multi-plugs from the alternator rectifier.

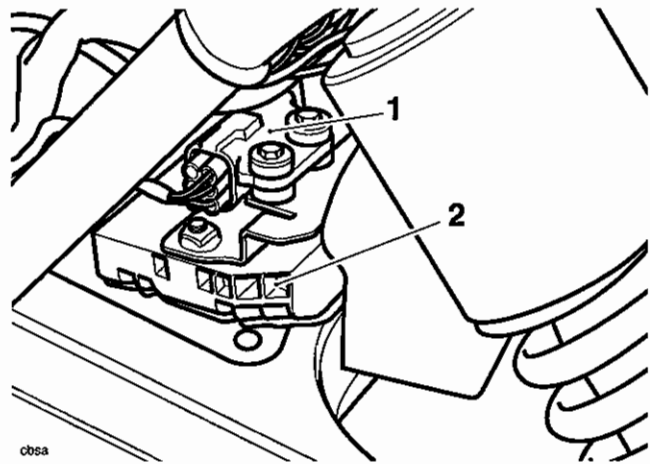

1. Rectifier
2. Multi-plugs

5. Release the two screws securing the rectifier to the battery box and withdraw the rectifier.

Installation

1. Position the rectifier to the battery box and secure with the two screws. Tighten the screws to **9 Nm**.
2. Reconnect the two multi-plugs to the rectifier.
3. Refit the left hand side cover as described on page 17.9.
4. Reconnect the battery positive (red) lead first.
5. Refit the rider's seat (see page 17.9).

Starter Motor

Removal

1. Remove the rider's seat as described on page 17.9.
2. Disconnect the battery, negative (black) lead first.
3. Remove the exhaust silencers and catalyst box as described on page 10.2.
4. Disconnect the solenoid connection from the main wiring harness.
5. Ease the rubber boot from the starter cable, release the nut and disconnect the cable.

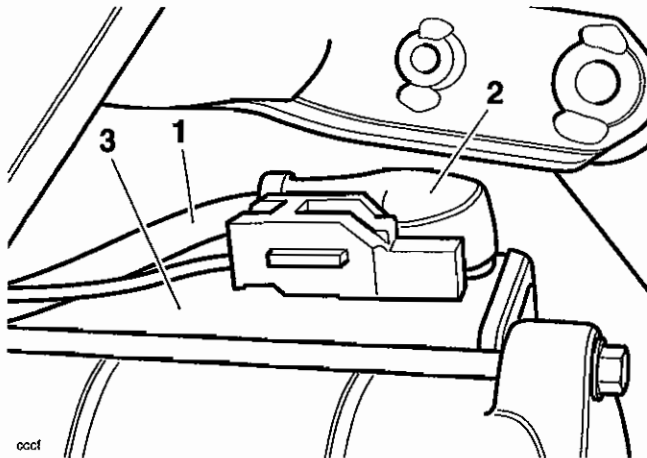

1. Boot
2. Cable
3. Starter motor

6. Release the two bolts securing the starter motor to the alternator cover.

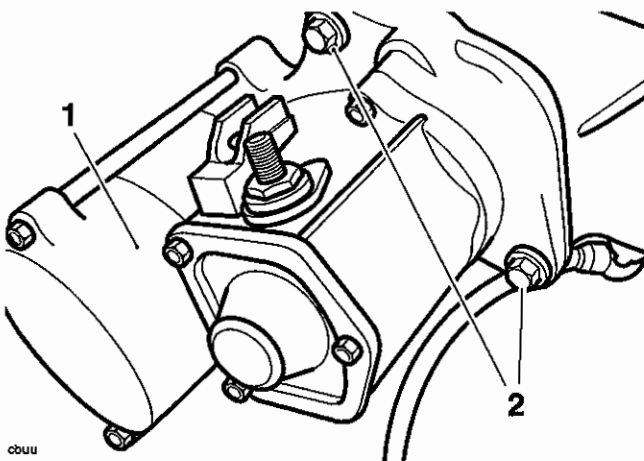

1. Starter motor
2. Bolts

7. Withdraw and remove the motor.

Installation

1. Fit a new O-ring to the starter motor.

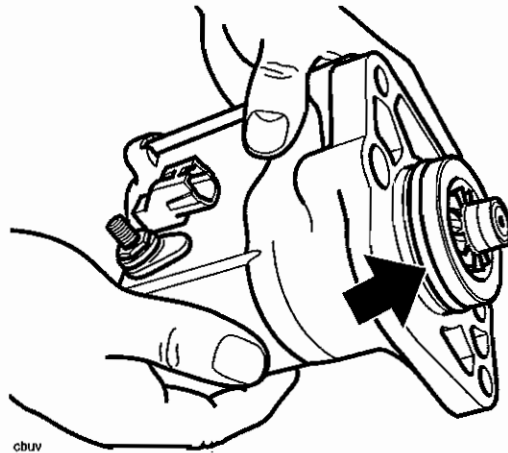

Arrowed - O-ring

2. Position the starter to the alternator cover and retain with the two bolts. Tighten the bolts to **27 Nm**.
3. Locate the starter cable to its connection pole. Fit the nut and tighten it to **7 Nm**.
4. Refit the boot.
5. Reconnect the solenoid to the main harness.
6. Refit the catalyst box and silencers as described on page 11.135.
7. Reconnect the battery, positive (red) lead first.
8. Refit the rider's seat.

Relays

Identification and location

Note:

- Relays can be found in two locations on the motorcycle, beneath the left and right hand side covers.

Relay identification – left hand side

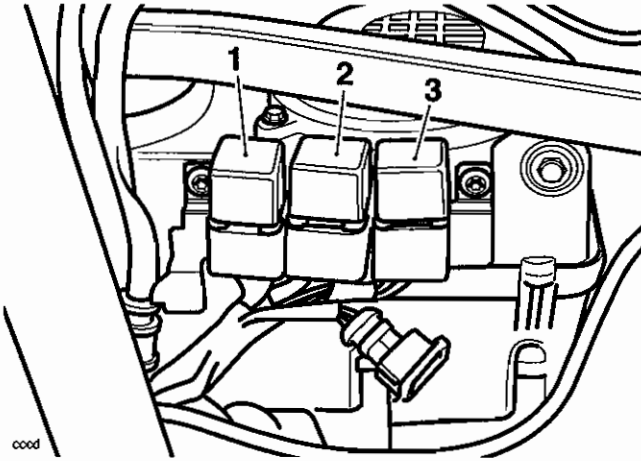

- Fuel Pump Relay
- EMS Relay
- Cooling Fan Relay

Relay identification – right hand side

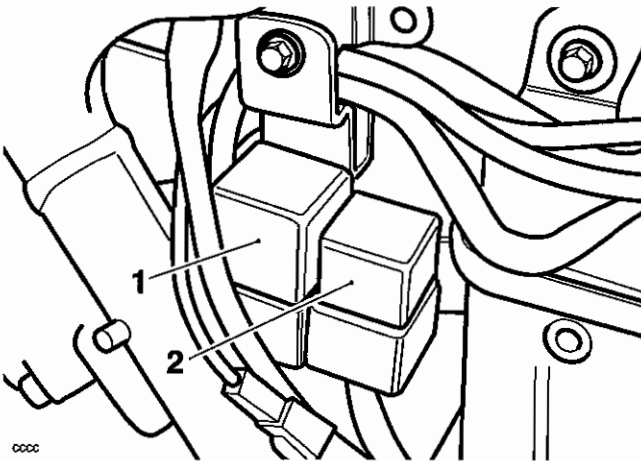

- Starter Relay
- Flasher Unit

ECM Connector Pin Numbering

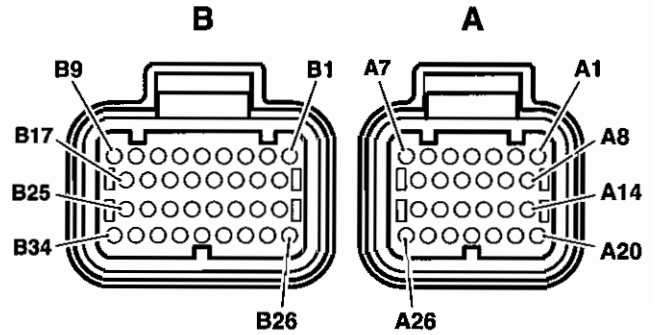

cbhs

The above illustration shows the pin numbering system used in the engine management and other electrical circuit diagrams.

The small connector's pins are prefixed A and the large connector's pins B. As viewed on the mating face with the ECM (as per the illustration), pins are numbered from right to left with number one in the top right corner.

Electrical System

Lighting Circuit

Key to circuit diagram

| Key | Item Description |
|-----|----------------------------------|
| 1 | Fuse Box (Fuses 2, 9 and 10) |
| 2 | Ignition Switch |
| 3 | Instrument Assembly |
| 4 | Instrument Illumination |
| 5 | Warning Lights |
| 6 | Engine Harness Connector |
| 7 | Oil Pressure Switch |
| 8 | Tail Lamp |
| 9 | Number Plate Lamp |
| 10 | Headlamp 2 |
| 11 | Headlamp 1 |
| 12 | Starter Relay |
| 13 | Headlamp Dip Switch |
| 14 | Accessory Heated Handlebar Grips |

Key To Wiring Colour Codes

| Code | Wiring Colour |
|------|---------------|
| B | Black |
| U | Blue |
| N | Brown |
| G | Green |
| S | Slate/Grey |
| O | Orange |
| K | Pink |
| R | Red |
| P | Purple |
| W | White |
| Y | Yellow |
| LG | Light Green |
| LU | Light Blue |

Circuit Diagram - Lighting

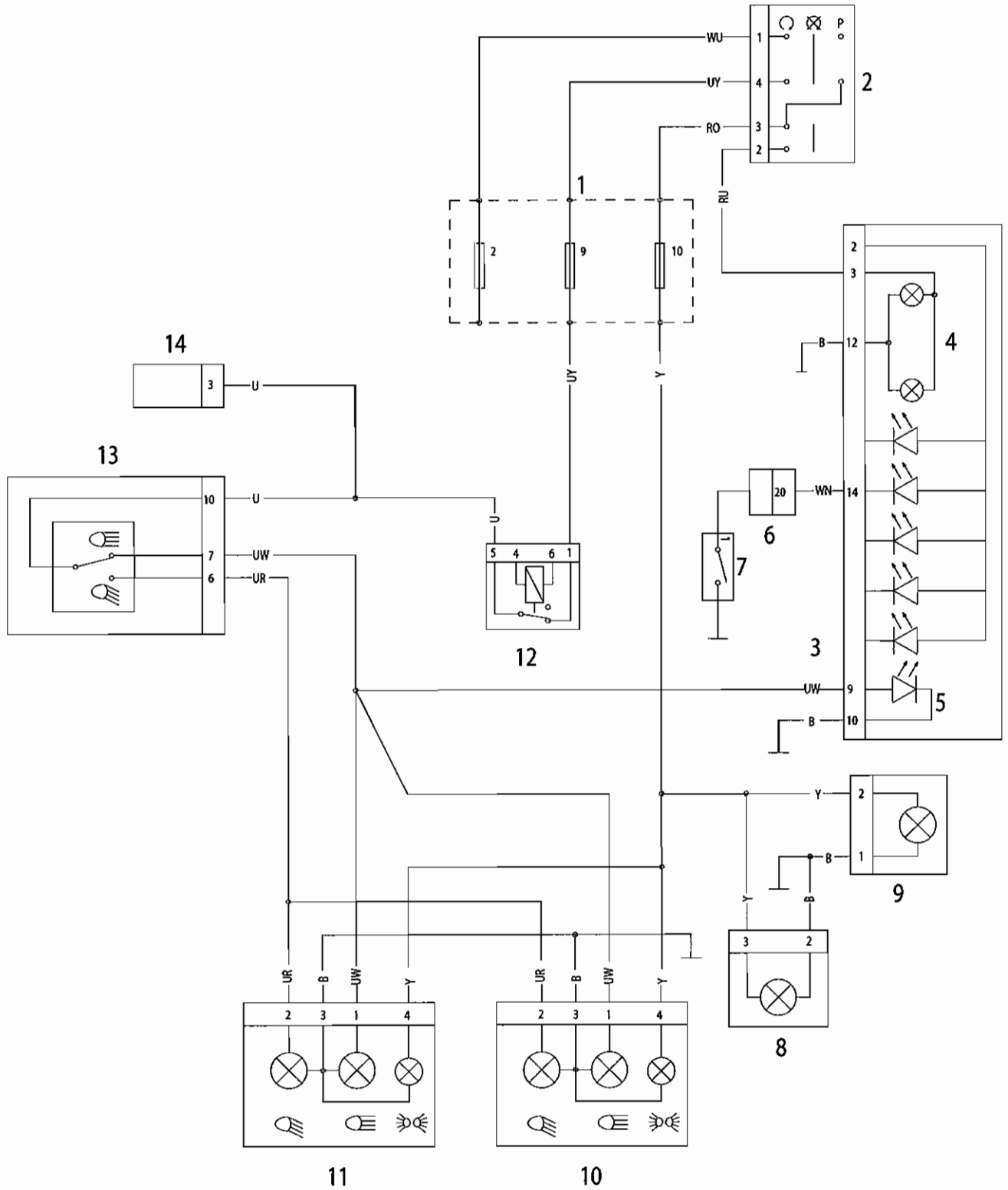

Electrical System

Starting and Charging Circuit

Key to circuit diagram

| Key | Item Description |
|-----|--|
| 1 | Battery |
| 2 | Starter Motor |
| 3 | Fuse 11 |
| 4 | Starter Relay |
| 5 | Engine Control Module |
| 6 | Gear Position Sensor |
| 7 | Clutch Switch |
| 8 | Sidestand Switch |
| 9 | Engine Management System Relay |
| 10 | Fuel Pump Relay |
| 11 | Instrument Assembly |
| 12 | Accessory Fuel Gauge |
| 13 | Alarm Control Unit Or Harness Link Connector |
| 14 | Starter Switch |
| 15 | Engine Kill Switch |
| 16 | Ignition Switch |
| 17 | Fuse Box (Fuses 5 and 9) |
| 18 | Fuse Box (Fuses 2 and 6) |
| 19 | Regulator / Rectifier |
| 20 | Alternator |

Key To Wiring Colour Codes

| Code | Wiring Colour |
|------|---------------|
| B | Black |
| U | Blue |
| N | Brown |
| G | Green |
| S | Slate/Grey |
| O | Orange |
| K | Pink |
| R | Red |
| P | Purple |
| W | White |
| Y | Yellow |
| LG | Light Green |
| LU | Light Blue |

Circuit Diagram - Starting and Charging

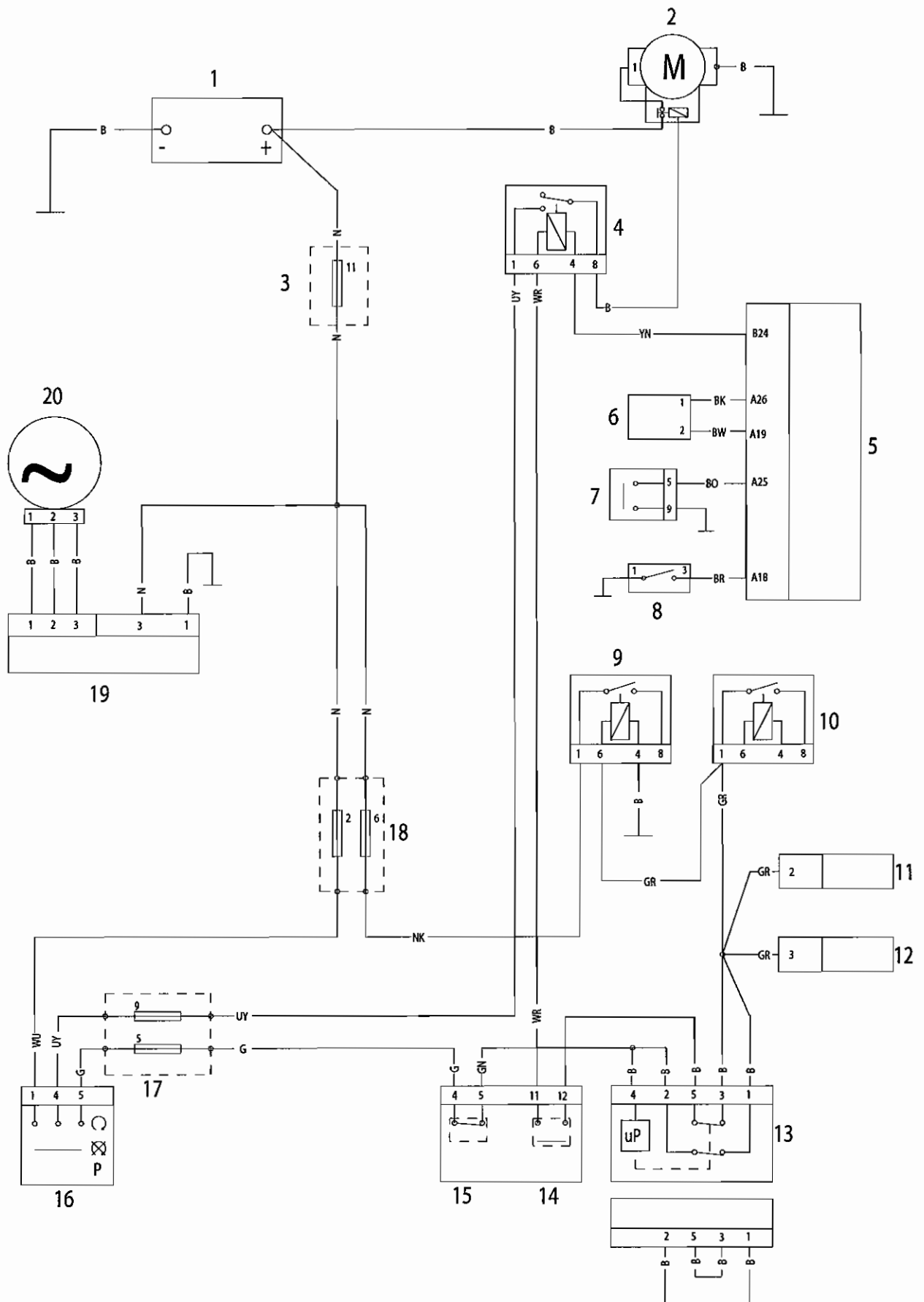

Electrical System

Auxiliary and Accessory Circuit

Key to circuit diagram

| Key | Item Description |
|-----|----------------------------------|
| 1 | Fuse Box (1, 2, 3, 4 and 8) |
| 2 | Ignition Switch |
| 3 | Front Brake Light Switch |
| 4 | Rear Brake Light Switch |
| 5 | Brake / Tail Light Assembly |
| 6 | Accessory Fuel Gauge |
| 7 | Diagnostic Connector |
| 8 | Rear Left Direction Indicator |
| 9 | Rear Right Direction Indicator |
| 10 | Accessory Alarm Control Unit |
| 11 | Front Left Direction Indicator |
| 12 | Front Right Direction Indicator |
| 13 | Instrument Assembly |
| 14 | Direction Indicator Switch |
| 15 | Horn Switch |
| 16 | Horn |
| 17 | Indicator Relay |
| 18 | Accessory Lights |
| 19 | Accessory Heated Handlebar Grips |
| 20 | Accessory Clock |
| 21 | Accessory Socket |

Key To Wiring Colour Codes

| Code | Wiring Colour |
|------|---------------|
| B | Black |
| U | Blue |
| N | Brown |
| G | Green |
| S | Slate/Grey |
| O | Orange |
| K | Pink |
| R | Red |
| P | Purple |
| W | White |
| Y | Yellow |
| LG | Light Green |
| LU | Light Blue |

Circuit Diagram - Auxiliary and Accessory

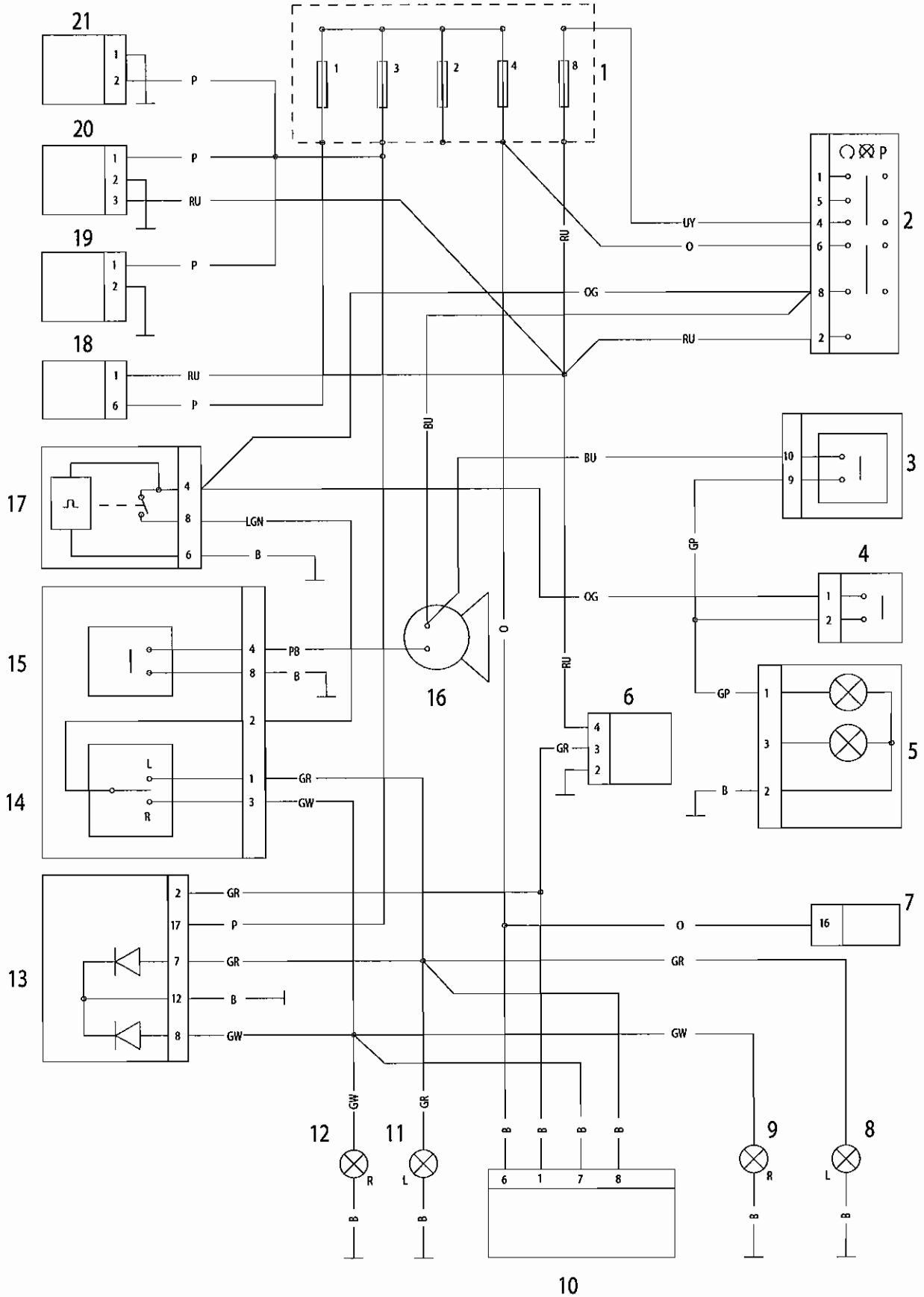

Electrical System

Complete System

Key to Circuit Diagram

| Key | Item Description |
|-----|--|
| 1 | Instrument Assembly |
| 2 | Vehicle Speed Sensor |
| 3 | Front Brake Lever Switch |
| 4 | Engine Kill Switch |
| 5 | Starter Button |
| 6 | Fuel Gauge (Accessory) |
| 7 | Engine Control Module |
| 8 | Gear Position Sensor |
| 9 | Lambda Sensor |
| 10 | Fuel Injector 1 |
| 11 | Fuel Injector 2 |
| 12 | Fuel Injector 3 |
| 13 | 2 nd Throttle Actuator |
| 14 | Idle Speed Control Actuator |
| 15 | Fall Detection Switch |
| 16 | Inlet Air Temperature Sensor |
| 17 | 2 nd Throttle Potentiometer |
| 18 | Throttle Potentiometer |
| 19 | Coolant Temperature Sensor |
| 20 | Oil Pressure Switch |
| 21 | Engine Sub-Harness Connector |
| 22 | Ambient Pressure Sensor |
| 23 | MAP Sensor |
| 24 | Purge Valve |
| 25 | Ignition Coil 1 |
| 26 | Ignition Coil 2 |
| 27 | Ignition Coil 3 |
| 28 | Engine Management Relay |
| 29 | Fuel Pump Relay |
| 30 | Fuel Pump and Level Sensor Assembly |
| 31 | Cooling Fan Relay |
| 32 | Cooling Fan |
| 33 | Diagnostic Connector |
| 34 | Sidestand Switch |
| 35 | Engine Earth |
| 36 | Crankshaft Sensor |
| 37 | Rear Brake Lever Switch |
| 38 | RH Rear Indicator |

| Key | Item Description |
|-----|--|
| 39 | Rear Light |
| 40 | Number Plate Light |
| 41 | LH Rear Indicator |
| 42 | Alarm Connector (Accessory) |
| 43 | Starter Motor / Solenoid Assembly |
| 44 | Battery |
| 45 | Starter Relay |
| 46 | Rectifier / Regulator |
| 47 | Alternator |
| 48 | Fuse Box |
| 49 | Ignition Switch |
| 50 | Accessory Light Connector |
| 51 | Accessory Socket |
| 52 | Heated Handlebar Grips Connector (Accessory) |
| 53 | Clock Connector (Accessory) |
| 54 | Clutch Lever Switch |
| 55 | Horn Button |
| 56 | Direction Indicator Switch |
| 57 | Headlamp Dip Switch |
| 58 | Direction Indicator Unit |
| 59 | LH Front Indicator |
| 60 | Position Light 1 |
| 61 | Headlamp 1 |
| 62 | Position Light 2 |
| 63 | Headlamp 2 |
| 64 | Horn |
| 65 | RH Front Indicator |

Circuit Diagram - Complete System

7

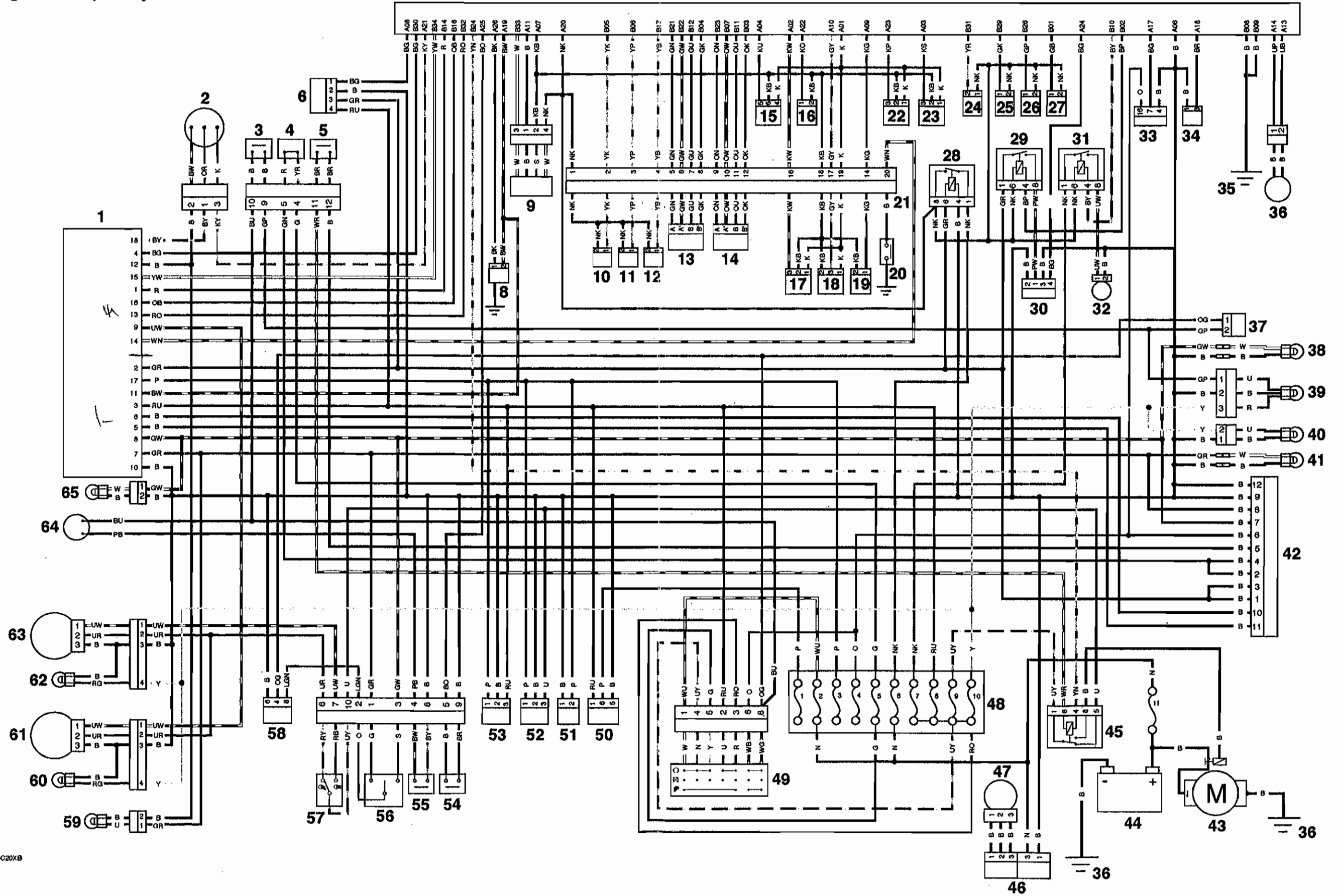

C20XB